

# Color image sensor heads for multi-function IA6008-FA22A

“Color contact image sensor” with optical system intended for Flatbed scanning. Optical technology established for sheet-feed scanning has been further advanced for Flatbed scanning.

## ●Applications

Image sensor heads device for multiple function facsimiles such as color scanner and multiple function printer.

## ●Features

- 1) Signal amplifier is built in to the image sensor IC in order to increase immunity to external noise.
- 2) Additionally, newly developed analog memory circuit and realizes high speed scanning.
- 3) The LED light source is mounted on the same substrate as the sensor chip which makes it possible to package the device with lighter weight and an extremely small size.
- 4) With the proprietary prism, the output signal is maintained uniformly.
- 5) The ceramic substrate is used for excellent dimensional accuracy and thermal stability.

## ●External dimensions (Unit : mm)

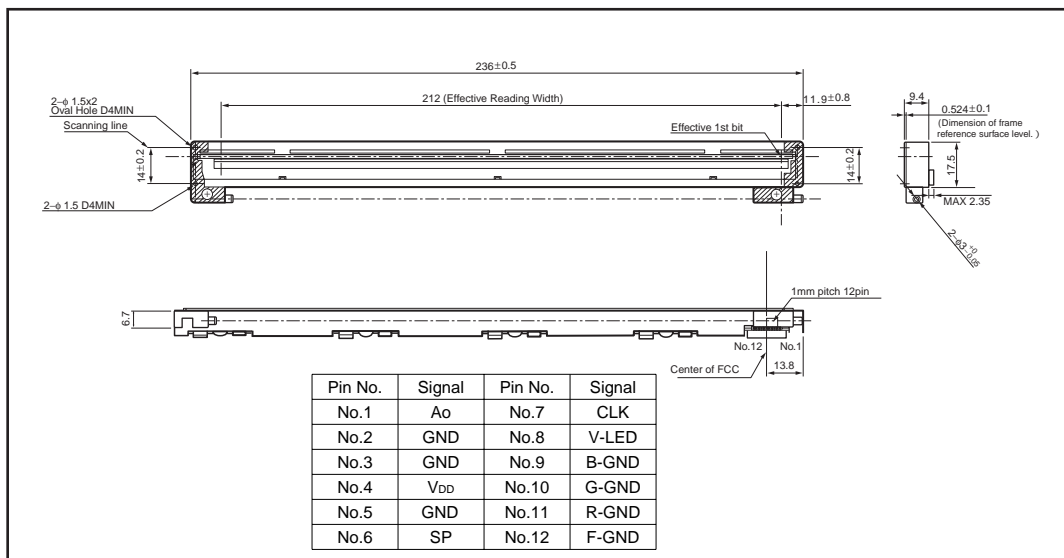

## Contact image sensor heads

---

### ●Characteristics

Parameter	Symbol	Typ.	Unit
Effective scanning width	–	212	mm
Primary scan dot density	–	600	dpi
Total dot number	–	5160	dots
Power supply voltage	V <sub>DD</sub>	5	V
Scanning speed	SLT	6.6	ms / line
Clock frequency	CLK	1.25	MHz *
Maximum dynamic range	VR <sub>max</sub>	0.5	V
Minimum dynamic range	VR <sub>mim.</sub>	0.25	V
Dark output	V <sub>od</sub>	1.73 ± 0.45	V
Operating temperature	–	5 to 45	°C

\*Analog signals are output at the double rate of clock frequency.

### ●Pin assignments

No.	Circuit	I / O	Function
1	A <sub>o</sub>	O	Analog output
2	GND	I	Ground
3	GND	I	Ground
4	V <sub>DD</sub>	I	Power supply
5	GND	I	Ground
6	SP	I	Start pulse
7	CLK	I	Clock
8	V-LED	I	LED power supply
9	B-GND	I	BLUE LED ground
10	G-GND	I	GREEN LED ground
11	R-GND	I	RED LED ground
12	F-GND	I	Frame ground

## Contact image sensor heads

## ●Timing chart

(a) CLK Timing Chart

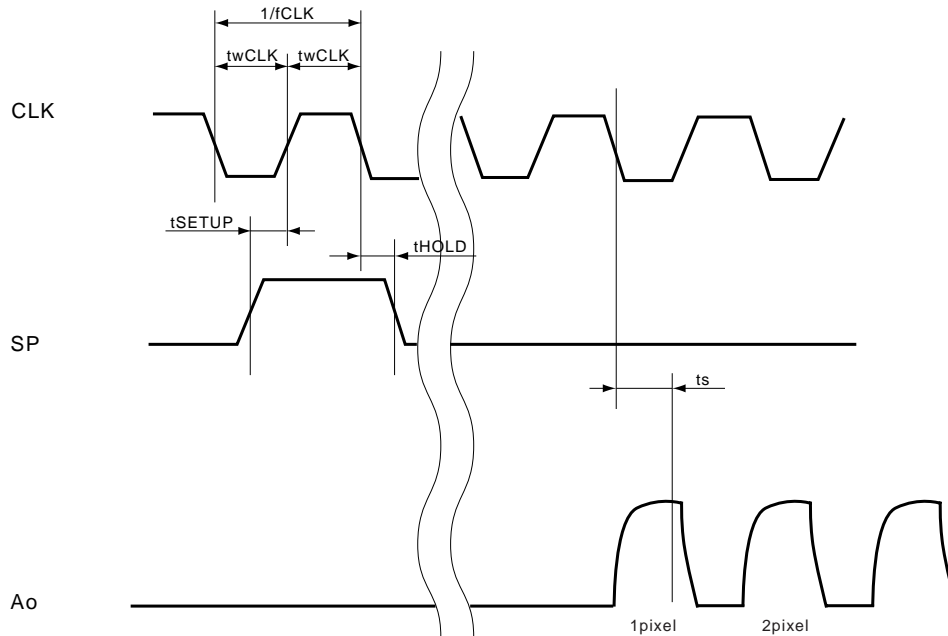

(b) Data Output Timing Chart

After turning on the SP pulse, the analog output starts from the setting up point of 27 clock pulse.

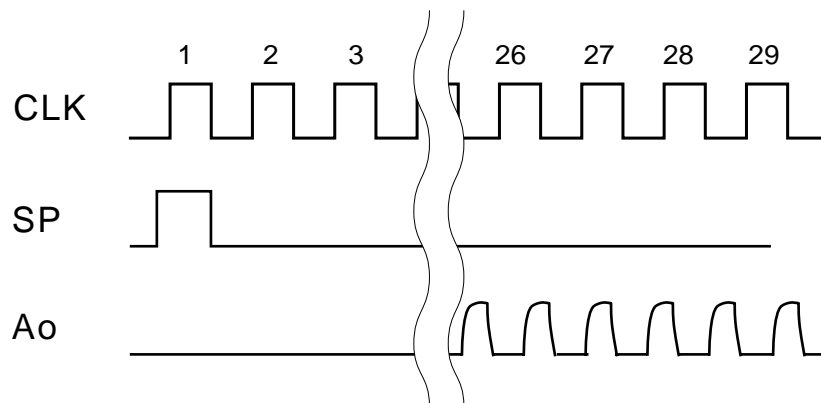

Note) The CLK section area which is over the effective pixel numbers  
(Output blank part) cannot be used as the analog Output standard level.

Contact image sensor heads

●Equivalent circuit

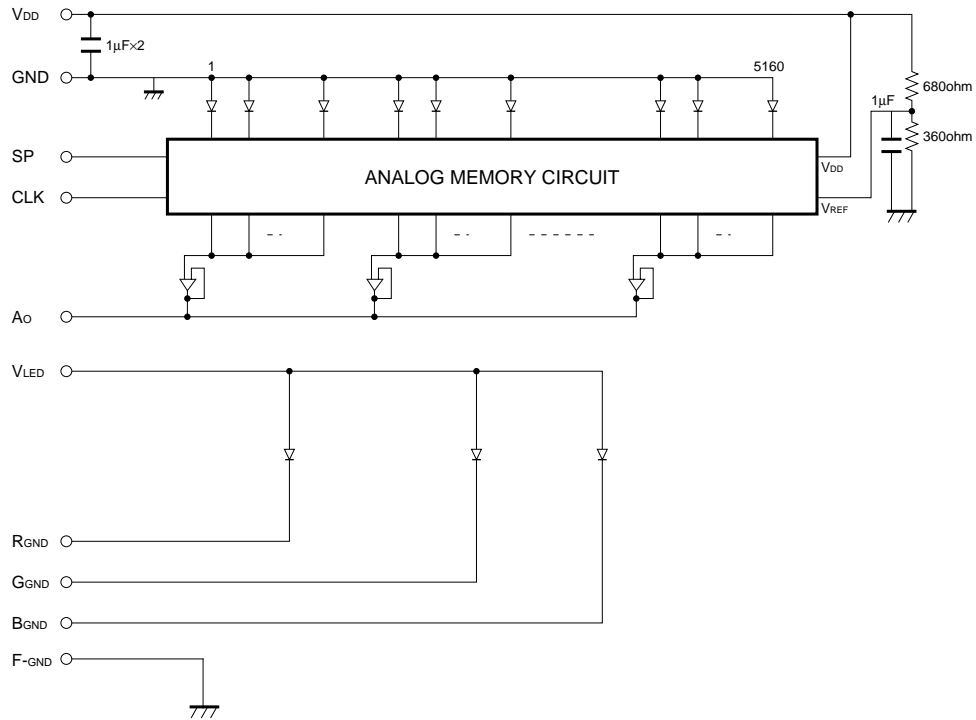

### Notes

- No technical content pages of this document may be reproduced in any form or transmitted by any means without prior permission of ROHM CO.,LTD.
- The contents described herein are subject to change without notice. The specifications for the product described in this document are for reference only. Upon actual use, therefore, please request that specifications to be separately delivered.
- Application circuit diagrams and circuit constants contained herein are shown as examples of standard use and operation. Please pay careful attention to the peripheral conditions when designing circuits and deciding upon circuit constants in the set.
- Any data, including, but not limited to application circuit diagrams information, described herein are intended only as illustrations of such devices and not as the specifications for such devices. ROHM CO.,LTD. disclaims any warranty that any use of such devices shall be free from infringement of any third party's intellectual property rights or other proprietary rights, and further, assumes no liability of whatsoever nature in the event of any such infringement, or arising from or connected with or related to the use of such devices.
- Upon the sale of any such devices, other than for buyer's right to use such devices itself, resell or otherwise dispose of the same, no express or implied right or license to practice or commercially exploit any intellectual property rights or other proprietary rights owned or controlled by
- ROHM CO., LTD. is granted to any such buyer.
- Products listed in this document use silicon as a basic material.  
Products listed in this document are no antiradiation design.

The products listed in this document are designed to be used with ordinary electronic equipment or devices (such as audio visual equipment, office-automation equipment, communications devices, electrical appliances and electronic toys).

Should you intend to use these products with equipment or devices which require an extremely high level of reliability and the malfunction of which would directly endanger human life (such as medical instruments, transportation equipment, aerospace machinery, nuclear-reactor controllers, fuel controllers and other safety devices), please be sure to consult with our sales representative in advance.

#### About Export Control Order in Japan

Products described herein are the objects of controlled goods in Annex 1 (Item 16) of Export Trade Control Order in Japan.

In case of export from Japan, please confirm if it applies to "objective" criteria or an "informed" (by MITI clause) on the basis of "catch all controls for Non-Proliferation of Weapons of Mass Destruction.