

# PRISM™ 2.4GHz Chip Set

## Direct Sequence Spread Spectrum Wireless Transceiver Chip Set

August 1997

### Features

- Provides Antenna-to-Bits™ Data Stream
- Low Voltage Operation from 2.7V to 5.5V
- 2.4GHz - 2.5GHz ISM Band Operation
- Single Heterodyne Conversion
- Programmable Antialiasing and Shaping Filters
- 10MHz to 400MHz IF Operation with RSSI
- Autonomous Half Duplex Direct Sequence Modem
- Selectable DBPSK, DQPSK Signalling
- Antenna Diversity Selection
- Direct Sequence Physical Layer (DS-PHY)
- Differential Data Encoding/Decoding
- Programmable 16-Bit PN Code
- Data Rates up to 4 MBPS DQPSK
- Power Management Control
- Low Profile PCMCIA-Compatible Surface Mount Packaging

### Applications

- Systems Targeting IEEE 802.11 Standard
- PCMCIA Wireless Transceiver
- WLAN RF Modems
- TDMA Packet Protocol Radios
- Part 15 Compliant Radio Links



### Description

The Harris 2.4GHz PRISM™ chip set is a highly integrated five-chip solution for RF modems employing Direct Sequence Spread Spectrum (DSSS) signaling. Significant integration of transmit and receive functions employ the following ICs: complete integrated DSSS engine, the HFA3824; a quadrature modulator/demodulator, integrated with an IF limiter amplifier with RSSI, the HFA3724, HFA3726; a combined LNA/Mixer and upconverter/preamplifier, the HFA3624; a high performance, low noise amplifier for increased receiver sensitivity, the HFA3424; a dual synthesizer, the HFA3524 and a monolithic RF power amplifier, the HFA3925. Each of the functions may be used individually or in any combination in support of a variety of RF modem applications.

The PRISM™ chip set is intended to support various data rates including systems targeting the proposed IEEE 802.11 standard "Direct Sequence Physical layer (DS-PHY)". Differential BPSK and QPSK signaling is employed with differential encoding and decoding of packetized data. A PN sequence rate of up to 22 MCPS is supported for up to a 16 chip PN code. Integrated programmable low pass filters are used on the HFA3724 to allow chip rates from 2.75 MCPS to 22 MCPS. A flexible general purpose data and control interface is provided for parameter configuration and for transferring data packets between the PHY and Media Access Control (MAC) layers. Data rates of up to 2 MBPS for DBPSK and 4 MBPS for DQPSK are supported.

### Typical Application Diagram

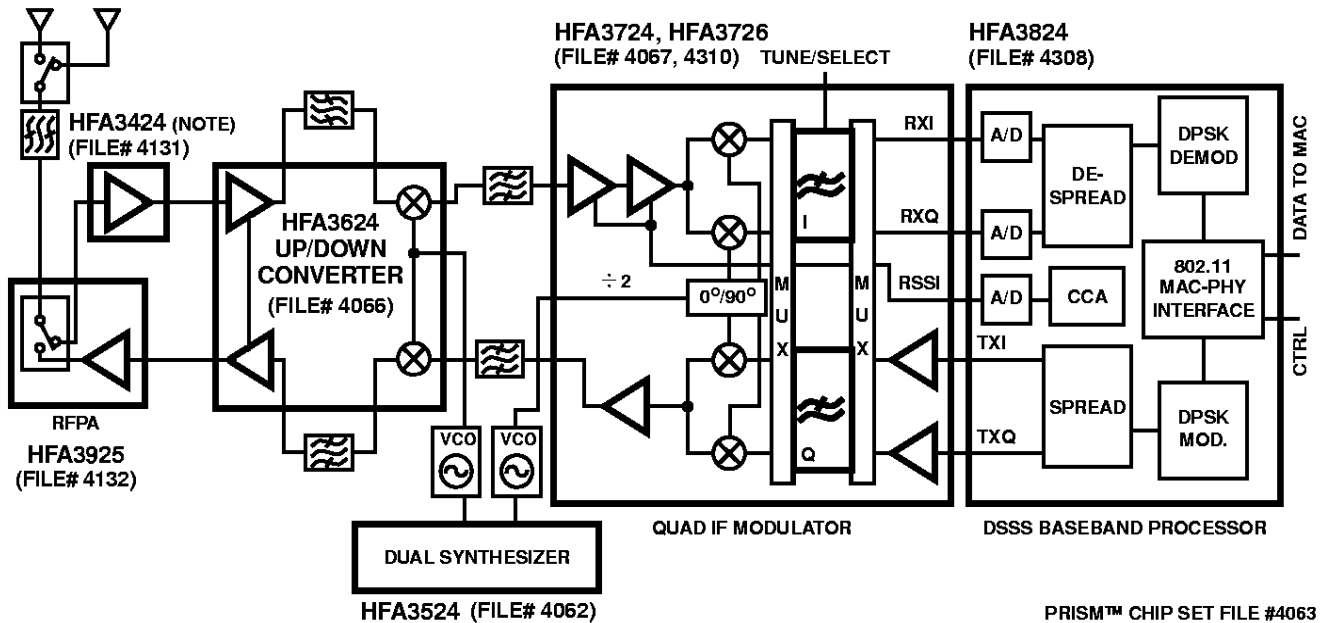

NOTE: Required for systems targeting 802.11 specifications.

PRISM™, the PRISM™ logo and Antenna-to-Bits™ are trademarks of Harris Corporation.

# PRISM™ 2.4GHz Chip Set

## Typical 802.11 DS-PHY System Level Performance (Note 5) (Measured at a diversity antenna port)

### Receiver

- Frequency Range . . . . . 2.4GHz - 2.4835GHz
- Step Size . . . . . 1MHz
- Cascaded Noise Figure . . . . . 6.8dB
- Sensitivity . . . . . -93dBm, 1 MBPS, 8E-2 FER (Note 1)  
-90dBm, 2 MBPS, 8E-2 FER (Note 1)
- Input Intercept Point . . . . . -17dBm
- IF Frequency . . . . . 280MHz
- IF Bandwidth . . . . . 17MHz
- Image Rejection . . . . . 80dB
- Adjacent Channel Rejection . . . . . >35dB
- Supply Voltage . . . . . 2.7V - 5.5V

### Transmitter

- Frequency Range . . . . . 2.4GHz - 2.4835GHz
- Step Size . . . . . 1MHz
- Output Power . . . . . +18dBm
- Spurious Outputs . . . . . Targeting ISM/802.11
- Transmit Spectral Mask . . . . . -32dB at First Side-Lobe
- IF Frequency . . . . . 280MHz
- Supply Voltage . . . . . 2.7V - 5.5V

### General Specifications

- Targeted Standard . . . . . IEEE 802.11
- Data Rate . . . . . 1 MBPS DBPSK  
2 MBPS DQPSK
- Range . . . . . 400ft Indoor (Note 2)  
3700ft Outdoor (Note 2)
- RX/TX Switching Speed . . . . . 2µs
- Power Savings Modes
  - Mode 1: 190mA at 1µs Recovery (Notes 3, 4)
  - Mode 2: 70mA at 25µs Recovery (Notes 3, 4)
  - Mode 3: 60mA at 2ms Recovery (Notes 3, 4)
  - Mode 4: 30mA at 5ms Recovery (Notes 3, 4)
- Average Current  
(Without Power Savings Modes) . . . . . 298mA (Note 6)
- Average Current  
(With Power Savings Modes) . . . . . 60mA (Note 7)

### NOTES:

1. FER = Frame Error Rate or Packet Error Rate.
2. Range Test using AND-C-107 omnidirectional antenna.
3. Supply current includes AM79C930 MAC Processor.
4. Recovery time is for the PRISM™ 2.4GHz Chip Set only and does not include programming latency of the AM79C930 MAC Processor.
5. Refer to Application Note AN9624 for more information on the "PRISM™ DSSS PC Card Wireless LAN Description".
6. Based on average current consumption for "typical" application.
7. Power savings modes refer to AN9665. Average radio current consumption for "typical" application.

All Harris Semiconductor products are manufactured, assembled and tested under **ISO9000** quality systems certification.

*Harris Semiconductor products are sold by description only. Harris Semiconductor reserves the right to make changes in circuit design and/or specifications at any time without notice. Accordingly, the reader is cautioned to verify that data sheets are current before placing orders. Information furnished by Harris is believed to be accurate and reliable. However, no responsibility is assumed by Harris or its subsidiaries for its use; nor for any infringements of patents or other rights of third parties which may result from its use. No license is granted by implication or otherwise under any patent or patent rights of Harris or its subsidiaries.*

## Sales Office Headquarters

For general information regarding Harris Semiconductor and its products, call **1-800-4-HARRIS**

### NORTH AMERICA

Harris Semiconductor  
P. O. Box 883, Mail Stop 53-210  
Melbourne, FL 32902  
TEL: 1-800-442-7747  
(407) 729-4984  
FAX: (407) 729-5321

### EUROPE

Harris Semiconductor  
Mercure Center  
100, Rue de la Fusee  
1130 Brussels, Belgium  
TEL: (32) 2.724.2111  
FAX: (32) 2.724.22.05

### ASIA

Harris Semiconductor PTE Ltd.  
No. 1 Tannery Road  
Cencon 1, #09-01  
Singapore 1334  
TEL: (65) 748-4200  
FAX: (65) 748-0400

