

Features

- One piece construction
- TIA/EIA 604 compliant
- Field installable
- Compatible with standard hand and machine polishing equipment
- 900um and 2.0 to 3.0mm cable compatible
- Materials:
 - Spring: Music wire
 - Ferrule: Zirconia
 - All other parts: Machined brass, nickel-plated



Specifications

- Insertion Loss: 0.15dB typical for Single-mode
- Return Loss: <-45dB typical for PC polish
- Operating Temp: -40° to 85° C
- Durability: >500 cycles
- Cable retention: >25Lb, straight pull
- Key Width: .0795 (2.02mm)

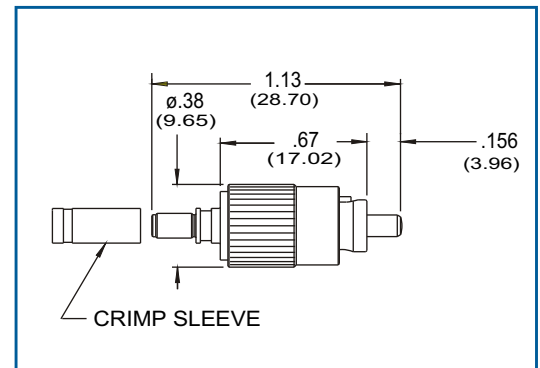

Part Numbers

| Description | Application | ID ¹ | P/N | Boot ² |
|-------------------|-------------|-----------------|---------|-------------------|
| FC External Crimp | SM | 126 | 2553-1 | Yellow, 3mm |
| FC External Crimp | MM | 127 | 2553-2 | Black, 3mm |
| FC External Crimp | MM | 144 | 2553-3 | Black, 3mm |
| FC External Crimp | MM | 173.5 | 2553-4 | Black, 3mm |
| FC External Crimp | APC | 126 | 2553-11 | Green, 3mm |
| FC External Crimp | MM | 142 | 2553-14 | Black, 3mm |
| FC External Crimp | MM | 231 | 2553-28 | Black, 3mm |

¹ Other ID's available, contact factory

² Boots listed are shipped with the connector unless otherwise specified at time of order. Contact factory for other colors and sizes.

Related Products

| | |
|---|----------------------|
| FC Wide Key, .0840 (2.14mm) | 2583 series |
| FC Adapters | 2523 series |
| High-Rel Aerospace FC Connectors | 2547 and 2550 series |
| Crimp Tool | 2560-2 |
| Bellcore Style Boot Kit (External Crimp Only) | 2579 series |

Data contained on this specification sheet is believed to be accurate as of the publication date. Johanson reserves the right to make changes deemed appropriate. Consult the factory for current engineering drawings and data.