

74147 Encoder

10-Line-To-4-Line Priority Encoder
Product Specification

Logic Products

FEATURES

- Encodes 10-line decimal to 4-line BCD
- Useful for 10-position switch encoding
- Used in code converters and generators

DESCRIPTION

The '147 9-input priority encoder accepts data from nine active-LOW inputs ($\bar{I}_1 - \bar{I}_9$) and provides a binary representation on the four active-LOW outputs ($A_0 - A_3$). A priority is assigned to each input so that when two or more inputs are simultaneously active, the input with the highest priority is represented on the output, with input line \bar{I}_9 having the highest priority.

The device provides the 10-line-to-4-line priority encoding function by use of the implied decimal "zero." The "zero" is encoded when all nine data inputs are HIGH, forcing all four outputs HIGH.

TYPE	TYPICAL PROPAGATION DELAY	TYPICAL SUPPLY CURRENT (TOTAL)
74147	10ns	46mA

ORDERING CODE

PACKAGES	COMMERCIAL RANGE $V_{CC} = 5V \pm 5\%$; $T_A = 0^\circ C$ to $+70^\circ C$
Plastic DIP	N74147N

NOTE:

For information regarding devices processed to Military Specifications see the Signetics Military Products Data Manual.

INPUT AND OUTPUT LOADING AND FAN-OUT TABLE

PINS	DESCRIPTION	74
All	Inputs	1uI
All	Outputs	10uI

NOTE:

A 74 unit load (uI) is understood to be $40\mu A I_{IH}$ and $-1.6mA I_{IL}$.

PIN CONFIGURATION

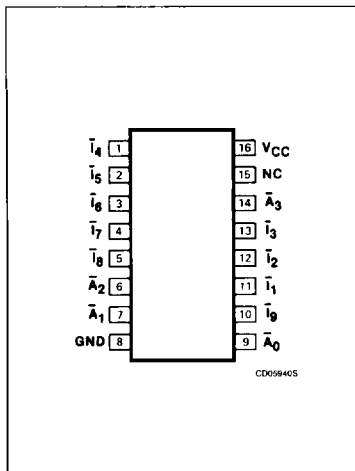

LOGIC SYMBOL

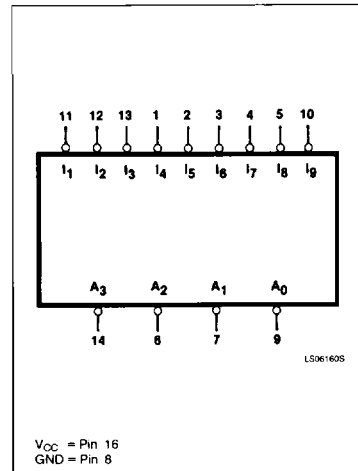

V_{CC} = Pin 16
GND = Pin 8

LOGIC SYMBOL (IEEE/IEC)

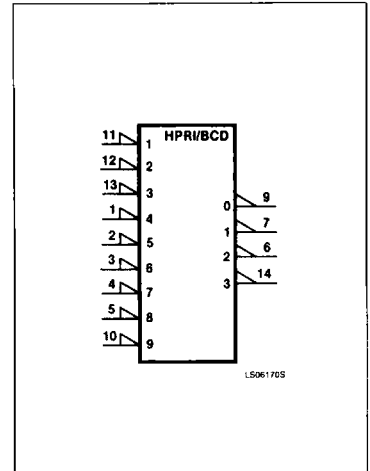

LS061705

Encoder

74147

LOGIC DIAGRAM

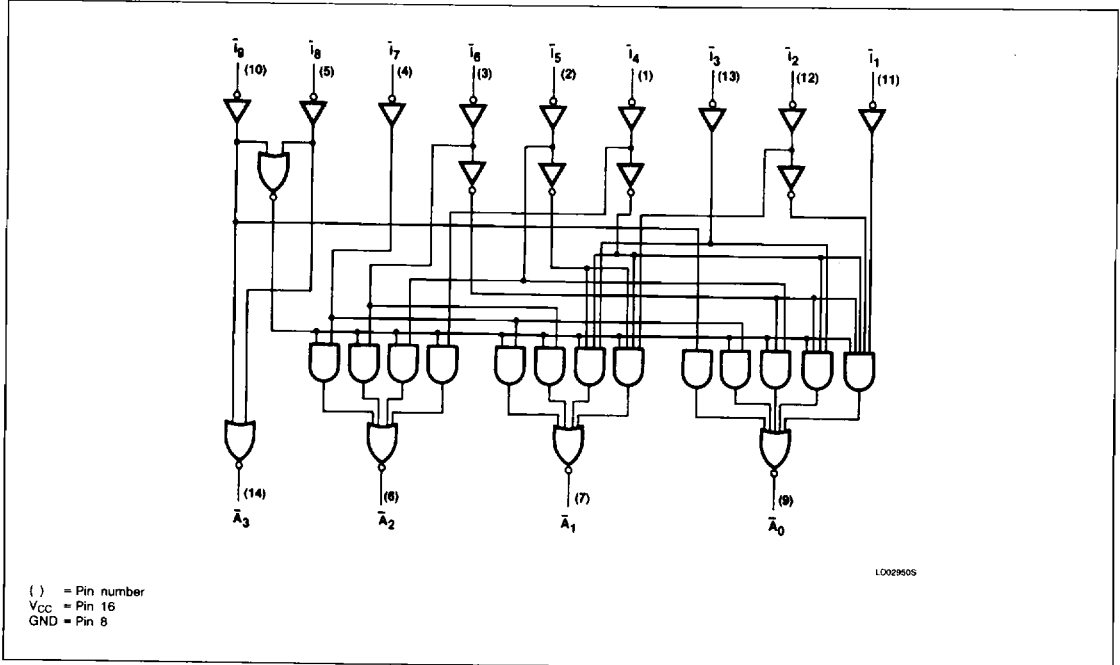

FUNCTION TABLE

INPUTS									OUTPUTS			
\bar{i}_1	\bar{i}_2	\bar{i}_3	\bar{i}_4	\bar{i}_5	\bar{i}_6	\bar{i}_7	\bar{i}_8	\bar{i}_9	\bar{A}_3	\bar{A}_2	\bar{A}_1	\bar{A}_0
H	H	H	H	H	H	H	H	H	H	H	H	H
X	X	X	X	X	X	X	X	L	L	H	H	L
X	X	X	X	X	X	X	L	H	L	H	L	L
X	X	X	X	X	L	H	H	H	H	L	L	L
X	X	X	X	L	H	H	H	H	H	L	H	L
X	X	X	L	H	H	H	H	H	H	L	L	L
X	X	L	H	H	H	H	H	H	H	H	L	L
X	L	H	H	H	H	H	H	H	H	H	L	L
L	H	H	H	H	H	H	H	H	H	H	H	L

H = HIGH voltage level
 L = LOW voltage level
 X = Don't care

Encoder

74147

ABSOLUTE MAXIMUM RATINGS (Over operating free-air temperature range unless otherwise noted.)

PARAMETER		74	UNIT
V_{CC}	Supply voltage	7.0	V
V_{IN}	Input voltage	-0.5 to +5.5	V
I_{IN}	Input current	-30 to +5	mA
V_{OUT}	Voltage applied to output in HIGH output state	-0.5 to $+V_{CC}$	V
T_A	Operating free-air temperature range	0 to 70	°C

RECOMMENDED OPERATING CONDITIONS

PARAMETER	74			UNIT	
	Min	Nom	Max		
V_{CC}	Supply voltage	4.75	5.0	5.25	V
V_{IH}	HIGH-level input voltage	2.0			V
V_{IL}	LOW-level input voltage			+0.8	V
I_{IK}	Input clamp current			-12	mA
I_{OH}	HIGH-level output current			-800	μA
I_{OL}	LOW-level output current			16	mA
T_A	Operating free-air temperature	0		70	°C

DC ELECTRICAL CHARACTERISTICS (Over recommended operating free-air temperature range unless otherwise noted.)

PARAMETER	TEST CONDITIONS ¹	74147			UNIT
		Min	Typ ²	Max	
V_{OH}	HIGH-level output voltage $V_{CC} = \text{MIN}$, $V_{IH} = \text{MIN}$, $V_{IL} = \text{MAX}$, $I_{OH} = \text{MAX}$	2.4	3.3		V
V_{OL}	LOW-level output voltage $V_{CC} = \text{MIN}$, $V_{IH} = \text{MIN}$, $V_{IL} = \text{MAX}$, $I_{OL} = \text{MAX}$		0.2	0.4	V
V_{IK}	Input clamp voltage $V_{CC} = \text{MIN}$, $I_I = I_{IK}$			-1.5	V
I_I	Input current at maximum input voltage $V_{CC} = \text{MAX}$, $V_I = 5.5\text{V}$			1.0	mA
I_{IH}	HIGH-level input current $V_{CC} = \text{MAX}$, $V_I = 2.4\text{V}$			40	μA
I_{IL}	LOW-level input current $V_{CC} = \text{MAX}$, $V_I = 0.4\text{V}$			-1.6	mA
I_{OS}	Short-circuit output current ³ $V_{CC} = \text{MAX}$	-35		-85	mA
I_{CC}	Supply current ⁴ (total) $V_{CC} = \text{MAX}$	Condition 1	50	70	mA
		Condition 2	42	62	mA

NOTES:

- For conditions shown as MIN or MAX, use the appropriate value specified under recommended operating conditions for the applicable type.
- All typical values are at $V_{CC} = 5\text{V}$, $T_A = 25^\circ\text{C}$.
- I_{OS} is tested with $V_{OUT} = +0.5\text{V}$ and $V_{CC} = V_{CC} \text{ MAX} + 0.5\text{V}$. Not more than one output should be shorted at a time and duration of the short circuit should not exceed one second.
- Condition 1: Measure I_{CC} with \bar{I}_7 grounded, other inputs and outputs open. Condition 2: Measure I_{CC} with all inputs and outputs open.

Encoder

74147

AC WAVEFORMS

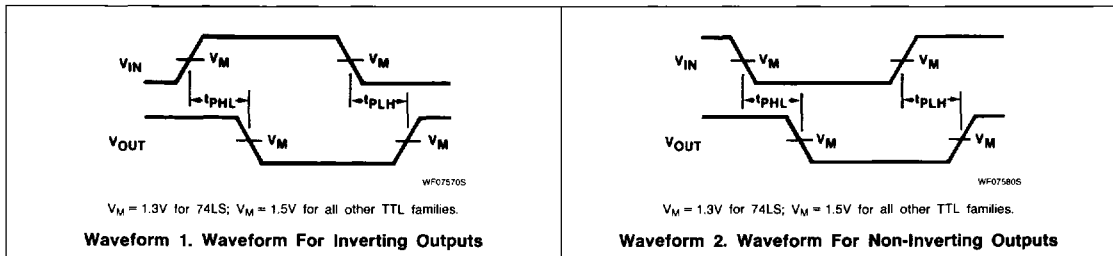

AC ELECTRICAL CHARACTERISTICS $T_A = 25^\circ C, V_{CC} = 5.0V$

PARAMETER	TEST CONDITIONS	74		UNIT
		$C_L = 15pF, R_L = 400\Omega$		
		Min	Max	
t_{PLH} t_{PHL} Propagation delay	Waveform 1 Out-of-phase output		19 19	ns
t_{PLH} t_{PHL} Propagation delay	Waveform 2 In-phase output		14 11	ns

TEST CIRCUITS AND WAVEFORMS

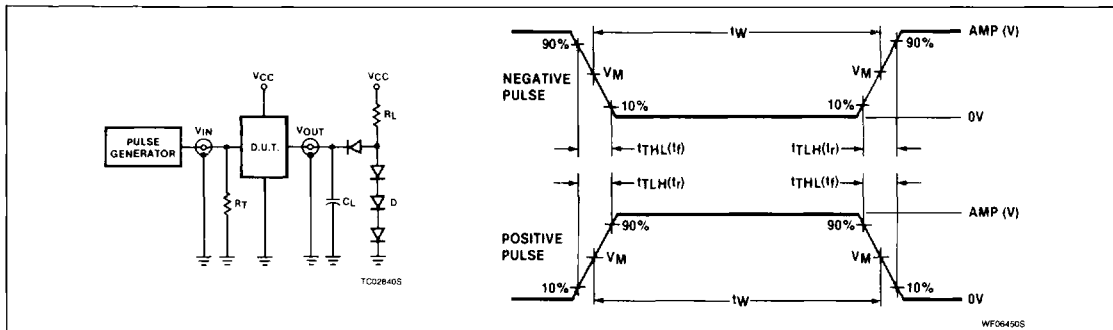

Test Circuit For 74 Totem-Pole Outputs

DEFINITIONS

R_L = Load resistor to V_{CC} ; see AC CHARACTERISTICS for value.

C_L = Load capacitance includes jig and probe capacitance; see AC CHARACTERISTICS for value.

R_T = Termination resistance should be equal to Z_{OUT} of Pulse Generators.

D = Diodes are 1N916, 1N3064, or equivalent.

t_{TLH}, t_{THL} Values should be less than or equal to the table entries.

Input Pulse Definition

FAMILY	INPUT PULSE REQUIREMENTS				
	Amplitude	Rep. Rate	Pulse Width	t_{TLH}	t_{THL}
74	3.0V	1MHz	500ns	7ns	7ns
74LS	3.0V	1MHz	500ns	15ns	6ns
74S	3.0V	1MHz	500ns	2.5ns	2.5ns