

## ARK2000PV 64-Bit GUI Accelerator

### General Description

The ARK Logic **ARK2000PV** uses true 64-bit display memory with a 64-bit graphics engine to get you all of the advantages of PCI and VESA interfaces. It also integrates a super VGA controller, and a high-speed interface circuit that will relieve the heavy processing load on the CPU ... allowing greater performance.

### Features

- Glueless PCI LOCAL BUS Interface (rev 2.0)
- Support Zero-Wait-State PCI burst cycles
- Direct 32-bit VESA VL-BUS Interface for Pentium, 486 DX2, DX, and SX series
- Advanced Graphics Co-processor accelerates applications running under GUI operating systems such as Microsoft Windows 3.x™, Nt™ OS/2™
- Extensive graphics functions
- Graphics acceleration for 4, 8, 16 and 24 bit pixels
- Graphics hardware cursor 64 x 64 x 2 or 32 x 32 x 2
- Linear addressing provides CPU direct access to frame buffer memory
- 100% register and BIOS compatible with IBM VGA
- Support VESA super VGA modes
- Support 132-column text modes
- Interface with 8-bit or 16-bit RAMDAC
- Advanced write buffer design allows for sustained Zero-Wait-State CPU writes at 50 MHz LCLK (VESA LOCAL BUS)
- Support up to 4 Mbytes of DRAM for 1600 x 1200 x 64K colors
- Support 256 x 4, 256 x 8, and 256 x 16 DRAM configurations
- Support asymmetrical DRAM and EDO DRAM
- Memory Clock up to 80 MHz for EDO DRAM or fast page DRAM with page cycle down to 25ns
- Display Resolutions up to 1600 x 1200
- Support VESA DPMS (Green PC)
- SynDAC™, GENDAC™, Combined Clock Gen. and RAMDAC) Interface
- Complete BIOS and GUI Drivers support
- Support VAFC (VESA Advanced Feature Connector)
- Support VESA DDC™ for Microsoft™ Plug and Play definition
- Complete PCI/VL-BUS PC board layout and manufacturing support
- 208-pin PQFP package, advance submicron CMOS technology

### Block Diagram

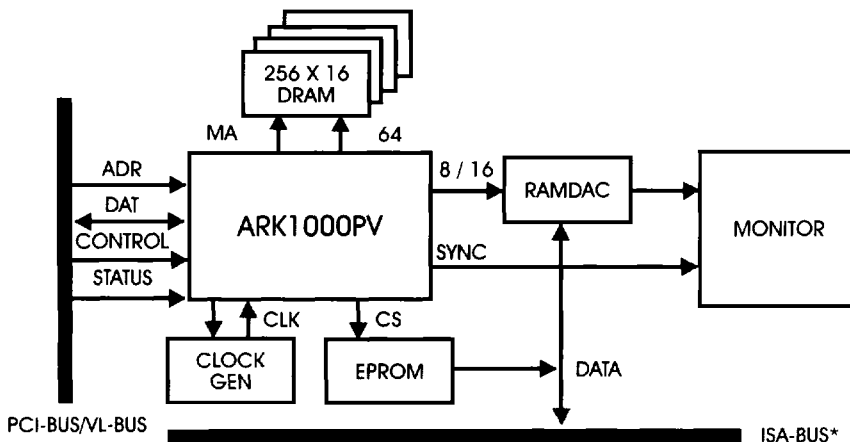

\*ONLY REQUIRED ON VL-BUS IMPLEMENTATION

