

HIGH FREQUENCY DEVICES SWITCH CONNECTOR

SWC TYPE (Please note: the SWC type is being superceded by the SWD type)

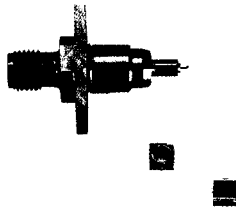

FEATURES

- The coaxial connector with switch is very useful for characteristic measurement of hand held phone and microwave circuit.
- It is possible to switch the line connection and disconnection easily by special probe.
- Small size, low profile. Size 3.4 x 3.3 x 1.9mm (L x W x H). Mounting dimension 11.2mm².
- Excellent characteristic. Low IL (0.1dB max.). V.S.W.R. 1.2 max. at DC to 3GHz. Isolation is 15dB min.
- Surface mountable and reflow solderable.
- Tape package available.

APPLICATIONS

Cellular phone, PHS. Other wireless and measurement equipment.

PART NUMBERING – RECEPTACLE

Part Number	Packaging	Quantity
MM8329-2600	Tray	Specify
MM8329-2600TB1	178mm Dia. Taping	1000pcs/reel
MM8329-2600TB2	330mm Dia. Taping	3000pcs/reel

Receptacle (coaxial connector with switch)
Probe for automatic measurement MM126012
L type probe with lock function MXGM76RY1000

SPECIFICATIONS

Item	Rating and Characteristics
Frequency Rating	From DC to 3GHz
VSWR	1.2 max.
Nominal Impedance	50Ω
Temperature Range	-40°C to +90°C
Voltage	250Vrms
Contact Resistance	25mΩ max.
Withstand Voltage	300VAC ± 20Vrms
Insulation Resistance	500MΩ min.
IL at ON switch	0.1dB max.
Isolation at OFF switch	15dB min.
Durability	50 cycles

DIMENSIONS: mm

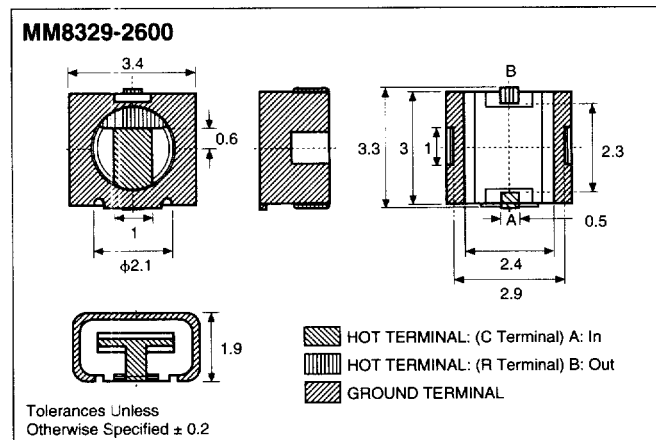

SWITCH MECHANISM

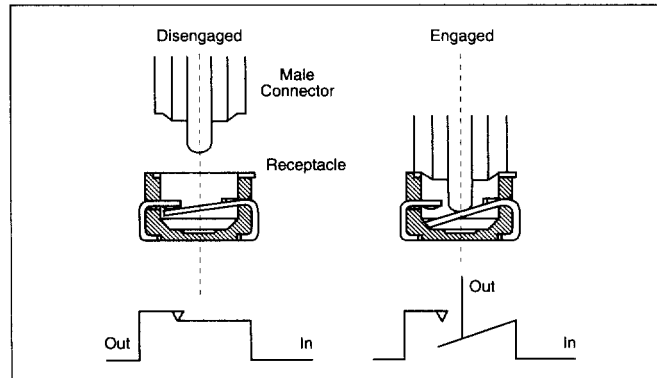

DIMENSIONS: mm

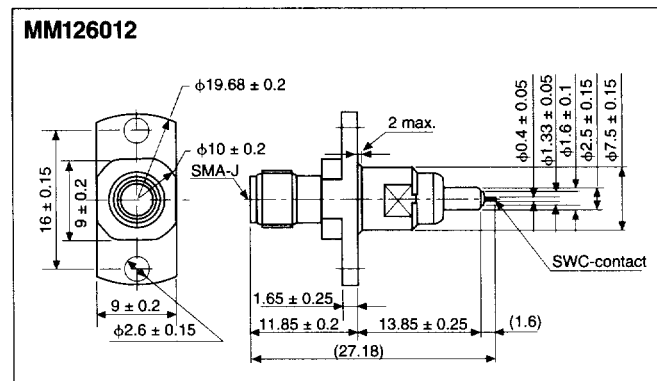

DIMENSIONS: mm

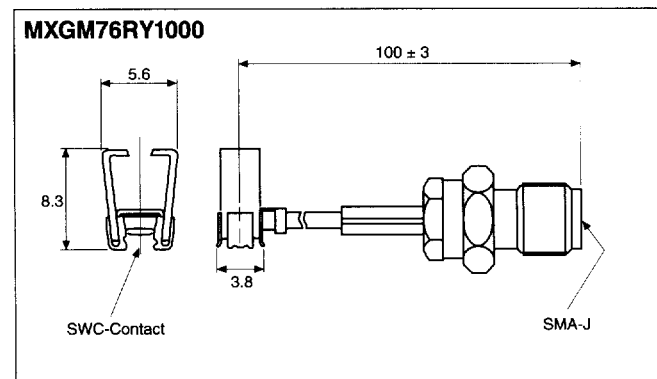

HIGH FREQUENCY DEVICES

HIGH FREQUENCY DEVICES SWITCH CONNECTOR



SWC TYPE (Please note: the SWC type is being superseded by the SWD type)

RATINGS AND CHARACTERISTICS

Item	Specifications	
	MM126012 ¹	MXGM76RY1000 ²
Frequency Rating	DC to 3GHz	DC to 3GHz
V.S.W.R	1.5 max.	1.3 max.
Nominal Impedance	50 Ω	50 Ω
Durability	100000	1000

¹Probe for automatic measurement MM126012

²L type probe with lock function MXGM76RY1000

MATERIALS AND FINISH – MM8329-2600

Part Name	Material	Finish
Elastomer	Insulation rubber	None
Case	Engineering Plastic	None
Ground terminal	Copper alloy	Silver plating
Hot terminal (A)	Copper alloy	Gold plating
Hot terminal (B)	Copper alloy	Gold plating

PROBE INSERTION

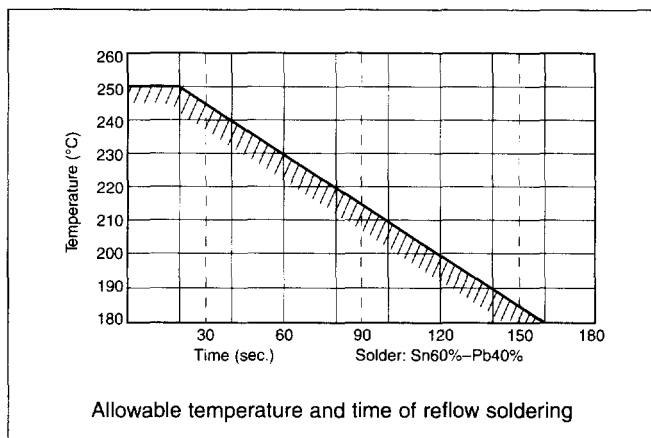
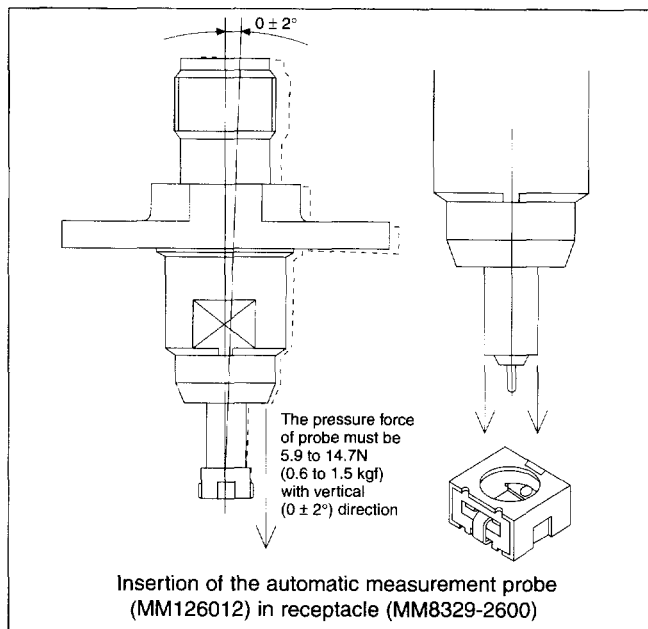

PROBE INSERTION

