

233-370
SuperSeal™ MIL-DTL-38999 Series III Type Receptacles
 USB 2.0/3.0 Plug-to-Receptacle or
 Receptacle-to-Receptacle Coupler • Size 15

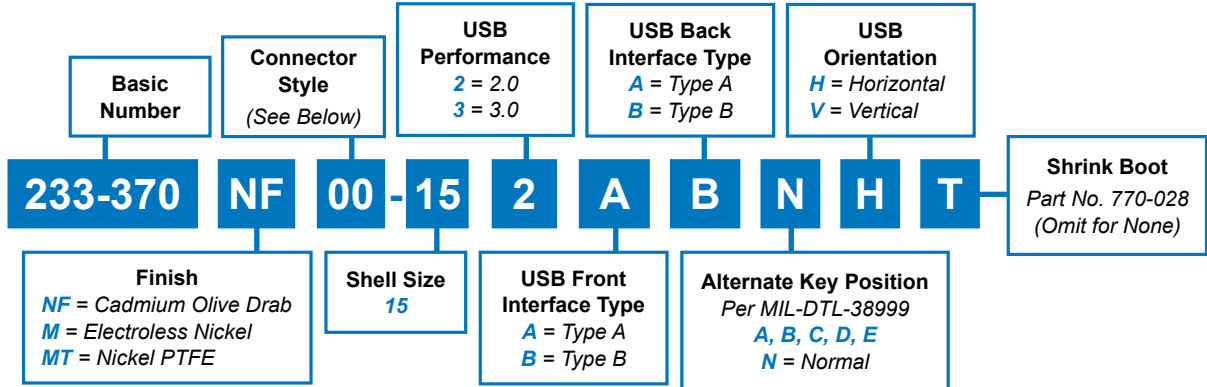

D38999 Type
USB Connectors



Square Flange Receptacle Jam Nut Receptacle
Front View

Connector Styles
 00 = Receptacle, Wall Mount with Slotted Holes
 07 = Receptacle, Jam Nut Mount

USB 2.0B, 3.0A and 3.0 B not currently available. In development.

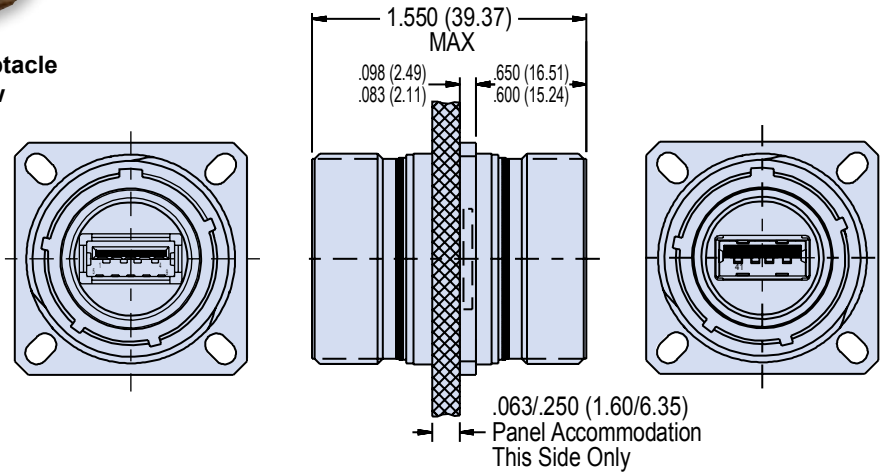

USB Orientation Options
(Partial Views Shown)

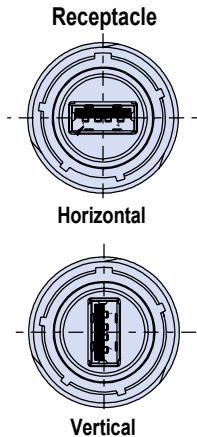

Square Flange Receptacle

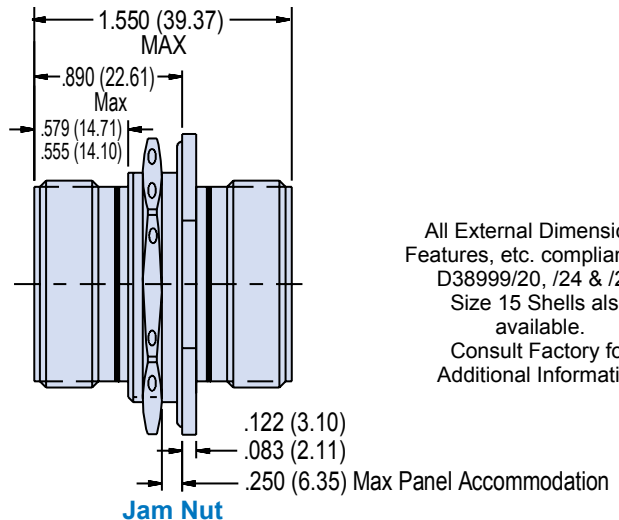

All External Dimensions, Features, etc. compliant with D38999/20, /24 & /26. Size 15 Shells also available. Consult Factory for Additional Information