

To all our customers

Regarding the change of names mentioned in the document, such as Hitachi Electric and Hitachi XX, to Renesas Technology Corp.

The semiconductor operations of Mitsubishi Electric and Hitachi were transferred to Renesas Technology Corporation on April 1st 2003. These operations include microcomputer, logic, analog and discrete devices, and memory chips other than DRAMs (flash memory, SRAMs etc.)

Accordingly, although Hitachi, Hitachi, Ltd., Hitachi Semiconductors, and other Hitachi brand names are mentioned in the document, these names have in fact all been changed to Renesas Technology Corp.

Thank you for your understanding. Except for our corporate trademark, logo and corporate statement, no changes whatsoever have been made to the contents of the document, and these changes do not constitute any alteration to the contents of the document itself.

Renesas Technology Home Page: www.renesas.com

Renesas Technology Corp.
Customer Support Dept.
April 1, 2003

RENESAS
Renesas Technology Corp.

H8/3006, H8/3007
HD6413006, HD6413007

Hardware Manual

HITACHI

ADE-602-145C

Rev. 4.0

1/29/00

Hitachi, Ltd.



Cautions

1. Hitachi neither warrants nor grants licenses of any rights of Hitachi's or any third party's patent, copyright, trademark, or other intellectual property rights for information contained in this document. Hitachi bears no responsibility for problems that may arise with third party's rights, including intellectual property rights, in connection with use of the information contained in this document.
2. Products and product specifications may be subject to change without notice. Confirm that you have received the latest product standards or specifications before final design, purchase or use.
3. Hitachi makes every attempt to ensure that its products are of high quality and reliability. However, contact Hitachi's sales office before using the product in an application that demands especially high quality and reliability or where its failure or malfunction may directly threaten human life or cause risk of bodily injury, such as aerospace, aeronautics, nuclear power, combustion control, transportation, traffic, safety equipment or medical equipment for life support.
4. Design your application so that the product is used within the ranges guaranteed by Hitachi particularly for maximum rating, operating supply voltage range, heat radiation characteristics, installation conditions and other characteristics. Hitachi bears no responsibility for failure or damage when used beyond the guaranteed ranges. Even within the guaranteed ranges, consider normally foreseeable failure rates or failure modes in semiconductor devices and employ systemic measures such as fail-safes, so that the equipment incorporating Hitachi product does not cause bodily injury, fire or other consequential damage due to operation of the Hitachi product.
5. This product is not designed to be radiation resistant.
6. No one is permitted to reproduce or duplicate, in any form, the whole or part of this document without written approval from Hitachi.
7. Contact Hitachi's sales office for any questions regarding this document or Hitachi semiconductor products.

Preface

The H8/3006 and H8/3007 is a series of high-performance microcontrollers that integrate system supporting functions together with an H8/300H CPU core.

The H8/300H CPU has a 32-bit internal architecture with sixteen 16-bit general registers, and a concise, optimized instruction set designed for speed. It can address a 16-Mbyte linear address space.

The on-chip supporting functions include RAM, 16-bit timers, 8-bit timers, a programmable timing pattern controller (TPC), a watchdog timer (WDT), a serial communication interface (SCI), an A/D converter, a D/A converter, I/O ports, and a DMA controller (DMAC).

The address space is divided into eight areas. The data bus width and access cycle length can be selected independently in each area, simplifying the connection of different types of memory. Four MCU operating modes (modes 1 to 4) are provided, offering a choice of data bus width initial value and address space.

With these features, the H8/3006 and H8/3007 offers easy implementation of compact, high-performance systems.

This manual describes the H8/3006 and H8/3007 Series hardware. For details of the instruction set, refer to the H8/300H Series Programming Manual.

List of Items Revised or Added for This Version

Page	Item	Description
3	1.1 Overview Table 1-1 Feature Watchdog timer (WDT)	Specification description amended
28	2.6.1 Instruction Set Overview	Number of instruction types amended
35	Table 2-7 Bit Manipulation Instructions	Function description added
41	2.6.5 Notes on Use of Bit Manipulation Instruction Explanation	Description added
45	Table 2-13 Effective Address Calculation	No. 1 in Addressing Mode and Instruction Format column amended
57	Table 3-1 Operating Mode Selection	Table amended
57	3.1.1 Operating Mode Selection	Description added
70	4.2.2 Reset Sequence	Description added
77	5.1.1 Features	Description added
144	Figure 6.15 Example of Wait State Insertion Timing	Figure amended
175	Figure 6.42 Example of Idle Cycle Operation (2) (ICIS0 = 1) (b) Idle cycle inserted	Bus cycle B amended
205	7.4.2 I/O Mode Table 7.6 Register Functions in I/O Mode	Description added Description added
207	7.4.3 Idle Mode	Description added
208	Table 7.7 Register Functions in Idle Mode	Description added
210	7.4.4 Repeat Mode	Description added
211	Table 7.8 Register Functions in Repeat Mode	Description added
226	7.4.8 DMAC Bus Cycle	Note added
248	8.3.2 Register Configuration Port 6 Data Direction Register (P6DDR)	Description amended
249	8.3.2 Register Configuration Port 6 Data Register (P6DR)	Description amended
253	8.5.1 Overview Figure 8.4 Port 8 Pin Configuration	Reference changed Description added
254	8.5.2 Register Configuration Port 8 Data Direction Register (P8DDR)	Description amended

Page	Item	Description
255	8.5.2 Register Configuration Port 8 Data Register (P8DR)	Description amended
258	8.6.2 Register Configuration Port 9 Data Direction Register (P9DDR)	Description amended
263	8.7.2 Register Configuration Port A Data Direction Register (PADDR)	Description amended
272	Figure 8.7 Port B Pin Configuration	Description added
273	8.8.2 Register Configuration Port B Data Direction Register (PBDDR)	Description amended
279 to 346	Section 9 16-Bit Timers	Register names changed TCNT → 16TCNT TCR → 16TCR
347 to 382	Section 10 8-Bit Timers	Register names changed TCNT → 8TCNT TCR → 8TCR TCSR → 8TCSR
351	Table 10.2 8-Bit Timer Register	8TCSR2 initial value changed
355	10.2.4 Timer Control Register (8TCR) Bits 4 and 3	Description amended
358	10.2.5 Timer Control/Status Registers (8TCSR) Bit 4	Description added
411	Table 12.2 WDT Registers	Note 3 added
462	Figure 13.5 Sample Flowchart for Transmitting Serial Data	Description added to (1)
502	Table 14.5 Bit Rates (bit/s) for Various BRR Settings (When n = 0)	20.00 MHz value added
503	Table 14.6 BRR Settings for Typical Bit Rates (bits/s) (When n = 0)	20.00 MHz value added
	Table 14.7 Maximum Bit Rate for Various Frequencies (Smart Card Interface Mode)	20.00 MHz value added
511	Figure 14.10 Procedure for Stopping and Restarting the Clock	Restart procedure amended
554	Figure 18.7 External Clock Output Setting Delay Timing	Figure amended
556	18.5.3 Usage Notes	Text of 1st note amended
640, 641	B.1 Addresses	Register names amended

Page	Item	Description
647	B.2 Functions P8DDR—Port 8 Data Direction Register	Note deleted
680	B.2 Functions TSTR—Timer Start Register	Description amended
681	B.2 Functions TSNC—Timer Syncro Register	Description amended
682	B.2 Functions TMDR—Timer Mode Register	Description amended
684	B.2 Functions TISRA—Timer Interrupt Status Register A	Description amended
685	B.2 Function TISRB—Timer Interrupt Status Register B	Description amended
686	B.2 Functions TISRC—Timer Interrupt Status Register C	Description amended
687	B.2 Functions 16TCR0—Timer Control Register 0	Register name changed
689	B.2 Functions 16TCNT0H/L—Timer Counter 0H/L	Register name changed
690	B.2 Functions 16TCR1—Timer Control Register 1	Register name changed
	B.2 Function 16TCNT1H/L—Timer Counter 1H/L	Register name changed
691	B.2 Functions 16TCR2—Timer Control Register 2	Register name changed
692	B.2 Functions 16TCNT2H/L—Timer Counter 2H/L	Register name changed
694	B.2 Functions 8TCR0—Timer Control Register 0 8TCR1—Timer Control Register 1	Register names changed, description amended
695	B.2 Functions 8TCSR0—Timer Control/Status Register 0	Register names changed, description amended
696	B.2 Functions 8TCSR1—Timer Control/Status Register 1	Register names changed, description amended
697	B.2 Functions 8TCNT0—Timer Counter 0 8TCNT1—Timer Counter 1	Register names changed
700	B.2 Functions 8TCR2—Timer Control Register 2 8TCR3—Timer Control Register 3	Register names changed, description amended

Page	Item	Description
701	B.2 Functions 8TCSR2—Timer Control/Status Register 2 8TCSR3—Timer Control/Status Register 3	Register names changed, description amended
702	B.2 Functions 8TCNT2—Timer Counter 2 8TCNT3—Timer Counter 3	Register name changed
723	B.2 Functions P6DR—Port 6 Data Register	Description amended
729	Figure C.1 Port 4 Block Diagram	Figure amended
730 to 732	Figure C.2(a) to Figure C.2(c) Port 6 Block Diagram	Figure amended
735 to 738	Figure C.4(a) to Figure C.4(d) Port 8 Block Diagram	Figure amended
739 to 744	Figure C.5(a) to Figure C.5(f) Port 8 Block Diagram	Figure amended
745 to 747	Figure C.6(a) to Figure C.6(c) Port A Block Diagram	Figure amended
748 to 753	Figure C.7(a) to Figure C.7(f) Port B Block Diagram	Figure amended

Contents

Section 1	Overview	1
1.1	Overview	1
1.2	Internal Block Diagram.....	5
1.3	Pin Description.....	6
1.3.1	Pin Arrangement	6
1.3.2	Pin Functions	8
1.3.3	Pin Assignments in Each Mode.....	13
Section 2	CPU.....	17
2.1	Overview	17
2.1.1	Features	17
2.1.2	Differences from H8/300 CPU	18
2.2	CPU Operating Modes	19
2.3	Address Space.....	20
2.4	Register Configuration	21
2.4.1	Overview	21
2.4.2	General Registers.....	22
2.4.3	Control Registers	23
2.4.4	Initial CPU Register Values.....	24
2.5	Data Formats.....	25
2.5.1	General Register Data Formats.....	25
2.5.2	Memory Data Formats.....	26
2.6	Instruction Set.....	28
2.6.1	Instruction Set Overview	28
2.6.2	Instructions and Addressing Modes.....	29
2.6.3	Tables of Instructions Classified by Function	30
2.6.4	Basic Instruction Formats	39
2.6.5	Notes on Use of Bit Manipulation Instructions	40
2.7	Addressing Modes and Effective Address Calculation.....	42
2.7.1	Addressing Modes	42
2.7.2	Effective Address Calculation	44
2.8	Processing States.....	48
2.8.1	Overview.....	48
2.8.2	Program Execution State	49
2.8.3	Exception-Handling State	49
2.8.4	Exception-Handling Sequences	51
2.8.5	Bus-Released State.....	52
2.8.6	Reset State	52
2.8.7	Power-Down State.....	52

2.9	Basic Operational Timing	53
2.9.1	Overview	53
2.9.2	On-Chip Memory Access Timing	53
2.9.3	On-Chip Supporting Module Access Timing	54
2.9.4	Access to External Address Space.....	55
Section 3 MCU Operating Modes		57
3.1	Overview	57
3.1.1	Operating Mode Selection	57
3.1.2	Register Configuration.....	58
3.2	Mode Control Register (MDCR)	58
3.3	System Control Register (SYSCR).....	59
3.4	Operating Mode Descriptions	62
3.4.1	Mode 1	62
3.4.2	Mode 2	62
3.4.3	Mode 3	62
3.4.4	Mode 4	62
3.5	Pin Functions in Each Operating Mode	63
3.6	Memory Map in Each Operating Mode	63
3.6.1	Note on Reserved Areas.....	63
Section 4 Exception Handling		67
4.1	Overview	67
4.1.1	Exception Handling Types and Priority.....	67
4.1.2	Exception Handling Operation	67
4.1.3	Exception Vector Table	68
4.2	Reset.....	70
4.2.1	Overview	70
4.2.2	Reset Sequence	70
4.2.3	Interrupts after Reset.....	72
4.3	Interrupts	73
4.4	Trap Instruction.....	73
4.5	Stack Status after Exception Handling	74
4.6	Notes on Stack Usage	74
Section 5 Interrupt Controller		77
5.1	Overview	77
5.1.1	Features	77
5.1.2	Block Diagram.....	78
5.1.3	Pin Configuration.....	79
5.1.4	Register Configuration.....	79
5.2	Register Descriptions	80
5.2.1	System Control Register (SYSCR).....	80

5.2.2	Interrupt Priority Registers A and B (IPRA, IPRB)	81
5.2.3	IRQ Status Register (ISR)	88
5.2.4	IRQ Enable Register (IER)	89
5.2.5	IRQ Sense Control Register (ISCR)	90
5.3	Interrupt Sources	91
5.3.1	External Interrupts	91
5.3.2	Internal Interrupts.....	92
5.3.3	Interrupt Vector Table	92
5.4	Interrupt Operation.....	96
5.4.1	Interrupt Handling Process	96
5.4.2	Interrupt Sequence	101
5.4.3	Interrupt Response Time.....	102
5.5	Usage Notes	103
5.5.1	Contention between Interrupt and Interrupt-Disabling Instruction	103
5.5.2	Instructions that Inhibit Interrupts	104
5.5.3	Interrupts during EEPMOV Instruction Execution	104
Section 6 Bus Controller		105
6.1	Overview.....	105
6.1.1	Features	105
6.1.2	Block Diagram.....	107
6.1.3	Pin Configuration.....	108
6.1.4	Register Configuration.....	109
6.2	Register Descriptions	110
6.2.1	Bus Width Control Register (ABWCR)	110
6.2.2	Access State Control Register (ASTCR).....	111
6.2.3	Wait Control Registers H and L (WCRH, WCRL).....	111
6.2.4	Bus Release Control Register (BRCR).....	115
6.2.5	Bus Control Register (BCR).....	116
6.2.6	Chip Select Control Register (CSCR)	118
6.2.7	DRAM Control Register A (DRCRA).....	119
6.2.8	DRAM Control Register B (DRCRB).....	121
6.2.9	Refresh Timer Control/Status Register (RTMCSR).....	124
6.2.10	Refresh Timer Counter (RTCNT)	125
6.2.11	Refresh Time Constant Register (RTCOR).....	126
6.3	Operation.....	127
6.3.1	Area Division.....	127
6.3.2	Bus Specifications	129
6.3.3	Memory Interfaces.....	130
6.3.4	Chip Select Signals	130
6.4	Basic Bus Interface	132
6.4.1	Overview.....	132
6.4.2	Data Size and Data Alignment.....	132

6.4.3	Valid Strobes.....	133
6.4.4	Memory Areas	134
6.4.5	Basic Bus Control Signal Timing	136
6.4.6	Wait Control.....	143
6.5	DRAM Interface	145
6.5.1	Overview.....	145
6.5.2	DRAM Space and RAS Output Pin Settings.....	145
6.5.3	Address Multiplexing.....	146
6.5.4	Data Bus.....	146
6.5.5	Pins Used for DRAM Interface	146
6.5.6	Basic Timing.....	147
6.5.7	Precharge State Control	148
6.5.8	Wait Control.....	149
6.5.9	Byte Access Control and CAS Output Pin	150
6.5.10	Burst Operation.....	152
6.5.11	Refresh Control.....	157
6.5.12	Examples of Use.....	160
6.5.13	Usage Notes	164
6.6	Interval Timer	167
6.6.1	Operation	167
6.7	Interrupt Sources.....	172
6.8	Burst ROM Interface.....	172
6.8.1	Overview.....	172
6.8.2	Basic Timing.....	172
6.8.3	Wait Control.....	173
6.9	Idle Cycle	174
6.9.1	Operation	174
6.9.2	Pin States in Idle Cycle	177
6.10	Bus Arbiter	178
6.10.1	Operation	178
6.11	Register and Pin Input Timing.....	181
6.11.1	Register Write Timing	181
6.11.2	BREQ Pin Input Timing.....	182
Section 7 DMA Controller.....		183
7.1	Overview.....	183
7.1.1	Features	183
7.1.2	Block Diagram.....	184
7.1.3	Functional Overview	185
7.1.4	Pin Configuration.....	186
7.1.5	Register Configuration.....	186
7.2	Register Descriptions (1) (Short Address Mode).....	188
7.2.1	Memory Address Registers (MAR).....	188

7.2.2	I/O Address Registers (IOAR).....	189
7.2.3	Execute Transfer Count Registers (ETCR)	189
7.2.4	Data Transfer Control Registers (DTCR).....	191
7.3	Register Descriptions (2) (Full Address Mode).....	194
7.3.1	Memory Address Registers (MAR).....	194
7.3.2	I/O Address Registers (IOAR).....	194
7.3.3	Execute Transfer Count Registers (ETCR)	195
7.3.4	Data Transfer Control Registers (DTCR).....	197
7.4	Operation.....	203
7.4.1	Overview.....	203
7.4.2	I/O Mode.....	205
7.4.3	Idle Mode.....	207
7.4.4	Repeat Mode	210
7.4.5	Normal Mode.....	214
7.4.6	Block Transfer Mode.....	217
7.4.7	DMAC Activation	222
7.4.8	DMAC Bus Cycle.....	224
7.4.9	Multiple-Channel Operation.....	230
7.4.10	External Bus Requests, DRAM Interface, and DMAC	231
7.4.11	NMI Interrupts and DMAC	232
7.4.12	Aborting a DMAC Transfer.....	233
7.4.13	Exiting Full Address Mode.....	234
7.4.14	DMAC States in Reset State, Standby Modes, and Sleep Mode.....	235
7.5	Interrupts	236
7.6	Usage Notes	237
7.6.1	Note on Word Data Transfer	237
7.6.2	DMAC Self-Access	237
7.6.3	Longword Access to Memory Address Registers	237
7.6.4	Note on Full Address Mode Setup.....	237
7.6.5	Note on Activating DMAC by Internal Interrupts.....	238
7.6.6	NMI Interrupts and Block Transfer Mode.....	239
7.6.7	Memory and I/O Address Register Values	239
7.6.8	Bus Cycle when Transfer is Aborted.....	240
7.6.9	Transfer Requests by A/D Converter.....	240
Section 8 I/O Ports		241
8.1	Overview.....	241
8.2	Port 4.....	244
8.2.1	Overview.....	244
8.2.2	Register Configuration.....	245
8.3	Port 6.....	247
8.3.1	Overview.....	247
8.3.2	Register Configuration.....	248

8.4	Port 7.....	251
8.4.1	Overview.....	251
8.4.2	Register Configuration.....	252
8.5	Port 8.....	253
8.5.1	Overview.....	253
8.5.2	Register Configuration.....	254
8.6	Port 9.....	257
8.6.1	Overview.....	257
8.6.2	Register Configuration.....	258
8.7	Port A.....	261
8.7.1	Overview.....	261
8.7.2	Register Configuration.....	263
8.8	Port B.....	272
8.8.1	Overview.....	272
8.8.2	Register Configuration.....	273
Section 9 16-Bit Timer.....		279
9.1	Overview.....	279
9.1.1	Features.....	279
9.1.2	Block Diagrams.....	282
9.1.3	Pin Configuration.....	285
9.1.4	Register Configuration.....	286
9.2	Register Descriptions.....	288
9.2.1	Timer Start Register (TSTR).....	288
9.2.2	Timer Synchro Register (TSNC).....	289
9.2.3	Timer Mode Register (TMDR).....	290
9.2.4	Timer Interrupt Status Register A (TISRA).....	292
9.2.5	Timer Interrupt Status Register B (TISRB).....	295
9.2.6	Timer Interrupt Status Register C (TISRC).....	298
9.2.7	Timer Counters (16TCNT).....	300
9.2.8	General Registers (GRA, GRB).....	301
9.2.9	Timer Control Registers (16TCR).....	302
9.2.10	Timer I/O Control Register (TIOR).....	304
9.2.11	Timer Output Level Setting Register C (TOLR).....	306
9.3	CPU Interface.....	309
9.3.1	16-Bit Accessible Registers.....	309
9.3.2	8-Bit Accessible Registers.....	311
9.4	Operation.....	312
9.4.1	Overview.....	312
9.4.2	Basic Functions.....	312
9.4.3	Synchronization.....	322
9.4.4	PWM Mode.....	324
9.4.5	Phase Counting Mode.....	328

9.4.6	Setting Initial Value of 16-Bit Timer Output.....	330
9.5	Interrupts	331
9.5.1	Setting of Status Flags	331
9.5.2	Timing of Clearing of Status Flags.....	333
9.5.3	Interrupt Sources and DMA Controller Activation	334
9.6	Usage Notes	335
Section 10	8-Bit Timers.....	347
10.1	Overview	347
10.1.1	Features	347
10.1.2	Block Diagram.....	349
10.1.3	Pin Configuration.....	350
10.1.4	Register Configuration.....	351
10.2	Register Descriptions	352
10.2.1	Timer Counters (8TCNT)	352
10.2.2	Time Constant Registers A (TCORA).....	353
10.2.3	Time Constant Registers B (TCORB)	354
10.2.4	Timer Control Register (8TCR).....	354
10.2.5	Timer Control/Status Registers (8TCSR)	357
10.3	CPU Interface.....	361
10.3.1	8-Bit Registers	361
10.4	Operation.....	363
10.4.1	8TCNT Count Timing	363
10.4.2	Compare Match Timing.....	364
10.4.3	Input Capture Signal Timing	365
10.4.4	Timing of Status Flag Setting	366
10.4.5	Operation with Cascaded Connection	367
10.4.6	Input Capture Setting.....	369
10.5	Interrupt.....	371
10.5.1	Interrupt Source	371
10.5.2	A/D Converter Activation.....	372
10.6	8-Bit Timer Application Example.....	372
10.7	Usage Notes	373
10.7.1	Contention between 8TCNT Write and Clear	373
10.7.2	Contention between 8TCNT Write and Increment.....	374
10.7.3	Contention between TCOR Write and Compare Match.....	375
10.7.4	Contention between TCOR Read and Input Capture.....	376
10.7.5	Contention between Counter Clearing by Input Capture and Counter Increment	377
10.7.6	Contention between TCOR Write and Input Capture.....	378
10.7.7	Contention between 8TCNT Byte Write and Increment in 16-Bit Count Mode (Cascaded Connection)	379
10.7.8	Contention between Compare Matches A and B.....	380
10.7.9	8TCNT Operation at Internal Clock Source Switchover.....	380

Section 11	Programmable Timing Pattern Controller (TPC)	383
11.1	Overview	383
11.1.1	Features	383
11.1.2	Block Diagram	384
11.1.3	Pin Configuration	385
11.1.4	Register Configuration	386
11.2	Register Descriptions	387
11.2.1	Port A Data Direction Register (PADDR)	387
11.2.2	Port A Data Register (PADR)	387
11.2.3	Port B Data Direction Register (PBDDR)	388
11.2.4	Port B Data Register (PBDR)	388
11.2.5	Next Data Register A (NDRA)	389
11.2.6	Next Data Register B (NDRB)	391
11.2.7	Next Data Enable Register A (NDERA)	393
11.2.8	Next Data Enable Register B (NDERB)	394
11.2.9	TPC Output Control Register (TPCR)	395
11.2.10	TPC Output Mode Register (TPMR)	398
11.3	Operation	400
11.3.1	Overview	400
11.3.2	Output Timing	401
11.3.3	Normal TPC Output	402
11.3.4	Non-Overlapping TPC Output	404
11.3.5	TPC Output Triggering by Input Capture	406
11.4	Usage Notes	407
11.4.1	Operation of TPC Output Pins	407
11.4.2	Note on Non-Overlapping Output	407
Section 12	Watchdog Timer	409
12.1	Overview	409
12.1.1	Features	409
12.1.2	Block Diagram	410
12.1.3	Pin Configuration	410
12.1.4	Register Configuration	411
12.2	Register Descriptions	412
12.2.1	Timer Counter (TCNT)	412
12.2.2	Timer Control/Status Register (TCSR)	413
12.2.3	Reset Control/Status Register (RSTCSR)	415
12.2.4	Notes on Register Access	417
12.3	Operation	419
12.3.1	Watchdog Timer Operation	419
12.3.2	Interval Timer Operation	420
12.3.3	Timing of Setting of Overflow Flag (OVF)	421
12.3.4	Timing of Setting of Watchdog Timer Reset Bit (WRST)	422

12.4	Interrupts	423
12.5	Usage Notes	423
Section 13 Serial Communication Interface		425
13.1	Overview	425
13.1.1	Features	425
13.1.2	Block Diagram	427
13.1.3	Pin Configuration	428
13.1.4	Register Configuration	429
13.2	Register Descriptions	430
13.2.1	Receive Shift Register (RSR)	430
13.2.2	Receive Data Register (RDR)	430
13.2.3	Transmit Shift Register (TSR)	431
13.2.4	Transmit Data Register (TDR)	431
13.2.5	Serial Mode Register (SMR)	432
13.2.6	Serial Control Register (SCR)	436
13.2.7	Serial Status Register (SSR)	440
13.2.8	Bit Rate Register (BRR)	446
13.3	Operation	455
13.3.1	Overview	455
13.3.2	Operation in Asynchronous Mode	457
13.3.3	Multiprocessor Communication	467
13.3.4	Synchronous Operation	473
13.4	SCI Interrupts	482
13.5	Usage Notes	483
13.5.1	Notes on Use of SCI	483
Section 14 Smart Card Interface		489
14.1	Overview	489
14.1.1	Features	489
14.1.2	Block Diagram	490
14.1.3	Pin Configuration	490
14.1.4	Register Configuration	491
14.2	Register Descriptions	492
14.2.1	Smart Card Mode Register (SCMR)	492
14.2.2	Serial Status Register (SSR)	494
14.2.3	Serial Mode Register (SMR)	496
14.2.4	Serial Control Register (SCR)	496
14.3	Operation	497
14.3.1	Overview	497
14.3.2	Pin Connections	498
14.3.3	Data Format	498
14.3.4	Register Settings	500

14.3.5	Clock	502
14.3.6	Transmitting and Receiving Data	504
14.4	Usage Notes	512
Section 15 A/D Converter.....		515
15.1	Overview.....	515
15.1.1	Features	515
15.1.2	Block Diagram.....	516
15.1.3	Pin Configuration.....	517
15.1.4	Register Configuration.....	518
15.2	Register Descriptions	519
15.2.1	A/D Data Registers A to D (ADDRA to ADDR D)	519
15.2.2	A/D Control/Status Register (ADCSR)	520
15.2.3	A/D Control Register (ADCR)	523
15.3	CPU Interface.....	524
15.4	Operation.....	525
15.4.1	Single Mode (SCAN = 0)	525
15.4.2	Scan Mode (SCAN = 1).....	527
15.4.3	Input Sampling and A/D Conversion Time	529
15.4.4	External Trigger Input Timing.....	530
15.5	Interrupts	531
15.6	Usage Notes	531
Section 16 D/A Converter.....		537
16.1	Overview.....	537
16.1.1	Features	537
16.1.2	Block Diagram.....	537
16.1.3	Pin Configuration.....	538
16.1.4	Register Configuration.....	538
16.2	Register Descriptions	539
16.2.1	D/A Data Registers 0 and 1 (DADR0/1)	539
16.2.2	D/A Control Register (DACR)	539
16.2.3	D/A Standby Control Register (DASTCR)	541
16.3	Operation.....	542
16.4	D/A Output Control	544
Section 17 RAM.....		545
17.1	Overview.....	545
17.1.1	Block Diagram.....	545
17.1.2	Register Configuration.....	546
17.2	System Control Register (SYSCR).....	547
17.3	Operation.....	548

Section 18	Clock Pulse Generator	549
18.1	Overview	549
18.1.1	Block Diagram.....	549
18.2	Oscillator Circuit.....	550
18.2.1	Connecting a Crystal Resonator.....	550
18.2.2	External Clock Input.....	552
18.3	Duty Adjustment Circuit.....	555
18.4	Prescalers	555
18.5	Frequency Divider.....	555
18.5.1	Register Configuration.....	555
18.5.2	Division Control Register (DIVCR)	555
18.5.3	Usage Notes	556
Section 19	Power-Down State.....	557
19.1	Overview	557
19.2	Register Configuration	559
19.2.1	System Control Register (SYSCR).....	559
19.2.2	Module Standby Control RegisterH (MSTCRH)	561
19.2.3	Module Standby Control Register L (MSTCRL)	562
19.3	Sleep Mode	564
19.3.1	Transition to Sleep Mode.....	564
19.3.2	Exit from Sleep Mode.....	564
19.4	Software Standby Mode.....	565
19.4.1	Transition to Software Standby Mode.....	565
19.4.2	Exit from Software Standby Mode	565
19.4.3	Selection of Waiting Time for Exit from Software Standby Mode.....	566
19.4.4	Sample Application of Software Standby Mode	567
19.4.5	Note.....	567
19.5	Hardware Standby Mode	568
19.5.1	Transition to Hardware Standby Mode.....	568
19.5.2	Exit from Hardware Standby Mode.....	568
19.5.3	Timing for Hardware Standby Mode.....	568
19.6	Module Standby Function.....	569
19.6.1	Module Standby Timing	569
19.6.2	Read/Write in Module Standby	569
19.6.3	Usage Notes	569
19.7	System Clock Output Disabling Function	570
Section 20	Electrical Characteristics	571
20.1	Absolute Maximum Ratings	571
20.2	Electrical Characteristics.....	572
20.2.1	DC Characteristics	572

20.2.2	AC Characteristics	582
20.2.3	A/D Conversion Characteristics	590
20.2.4	D/A Conversion Characteristics	592
20.3	Operational Timing	593
20.3.1	Clock Timing	593
20.3.2	Control Signal Timing	594
20.3.3	Bus Timing	596
20.3.4	DRAM Interface Bus Timing	602
20.3.5	TPC and I/O Port Timing.....	605
20.3.6	Timer Input/Output Timing	606
20.3.7	SCI Input/Output Timing.....	607
20.3.8	DMAC Timing.....	608
Appendix A Instruction Set		609
A.1	Instruction List	609
A.2	Operation Code Map	624
A.3	Number of States Required for Execution	627
Appendix B Internal I/O Registers.....		636
B.1	Addresses	636
B.2	Functions.....	645
Appendix C I/O Port Block Diagrams		729
C.1	Port 4 Block Diagram	729
C.2	Port 6 Block Diagrams	730
C.3	Port 7 Block Diagrams	734
C.4	Port 8 Block Diagrams	735
C.5	Port 9 Block Diagrams	739
C.6	Port A Block Diagrams.....	745
C.7	Port B Block Diagrams	748
Appendix D Pin States		754
D.1	Port States in Each Mode	754
D.2	Pin States at Reset.....	760
Appendix E Timing of Transition to and Recovery from Hardware Standby Mode		762
Appendix F List of Product Codes		763
Appendix G Package Dimensions		764

Appendix H	Comparison of H8/300H Series Product Specifications.....	767
H.1	Differences between H8/3067 and H8/3062 Series, H8/3048 Series, H8/3007 and H8/3006, and H8/3002	767
H.2	Comparison of Pin Functions of 100-Pin Package Products (FP-100B, TFP-100B)	770

Section 1 Overview

1.1 Overview

The H8/3006 and H8/3007 are a series of microcontrollers (MCUs) that integrate system supporting functions together with an H8/300H CPU core having an original Hitachi architecture.

The H8/300H CPU has a 32-bit internal architecture with sixteen 16-bit general registers, and a concise, optimized instruction set designed for speed. It can address a 16-Mbyte linear address space. Its instruction set is upward-compatible at the object-code level with the H8/300 CPU, enabling easy porting of software from the H8/300 Series.

The on-chip system supporting functions include RAM, a 16-bit timer, an 8-bit timer, a programmable timing pattern controller (TPC), a watchdog timer (WDT), a serial communication interface (SCI), an A/D converter, a D/A converter, I/O ports, a direct memory access controller (DMAC), and other facilities.

Four MCU operating modes offer a choice of bus width and address space size.

Table 1-1 summarizes the features of the H8/3006 and H8/3007.

Table 1-1 Features

Feature	Description
CPU	<p>Upward-compatible with the H8/300 CPU at the object-code level</p> <p>General-register machine</p> <ul style="list-style-type: none">• Sixteen 16-bit general registers (also usable as sixteen 8-bit registers plus eight 16-bit registers, or as eight 32-bit registers) <p>High-speed operation</p> <ul style="list-style-type: none">• Maximum clock rate: 20 MHz• Add/subtract: 100 ns• Multiply/divide: 700 ns <p>16-Mbyte address space</p> <p>Instruction features</p> <ul style="list-style-type: none">• 8/16/32-bit data transfer, arithmetic, and logic instructions• Signed and unsigned multiply instructions (8 bits x 8 bits, 16 bits x 16 bits)• Signed and unsigned divide instructions (16 bits ÷ 8 bits, 32 bits ÷ 16 bits)• Bit accumulator function• Bit manipulation instructions with register-indirect specification of bit positions

Feature	Description
Memory	<p>H8/3007</p> <ul style="list-style-type: none"> RAM: 4 kbytes <p>H8/3006</p> <ul style="list-style-type: none"> RAM: 2 kbytes
Interrupt controller	<ul style="list-style-type: none"> Seven external interrupt pins: NMI, $\overline{\text{IRQ}}_0$ to $\overline{\text{IRQ}}_5$ 36 internal interrupts Three selectable interrupt priority levels
Bus controller	<ul style="list-style-type: none"> Address space can be partitioned into eight areas, with independent bus specifications in each area Chip select output available for areas 0 to 7 8-bit access or 16-bit access selectable for each area Two-state or three-state access selectable for each area Selection of two wait modes Number of program wait states selectable for each area Direct connection of burst ROM Direct connection of up to 8-Mbyte DRAM (or DRAM interface can be used as interval timer) Bus arbitration function
DMA controller (DMAC)	<p>Short address mode</p> <ul style="list-style-type: none"> Maximum four channels available Selection of I/O mode, idle mode, or repeat mode Can be activated by compare match/input capture A interrupts from 16-bit timer channels 0 to 2, conversion-end interrupts from the A/D converter, transmit-data-empty and receive-data-full interrupts from the SCI, or external requests <p>Full address mode</p> <ul style="list-style-type: none"> Maximum two channels available Selection of normal mode or block transfer mode Can be activated by compare match/input capture A interrupts from 16-bit timer channels 0 to 2, conversion-end interrupts from the A/D converter, external requests, or auto-request

Feature	Description
16-bit timer, 3 channels	<ul style="list-style-type: none"> • Three 16-bit timer channels, capable of processing up to six pulse outputs or six pulse inputs • 16-bit timer counter (channels 0 to 2) • Two multiplexed output compare/input capture pins (channels 0 to 2) • Operation can be synchronized (channels 0 to 2) • PWM mode available (channels 0 to 2) • Phase counting mode available (channel 2) • DMAC can be activated by compare match/input capture A interrupts (channels 0 to 2)
8-bit timer, 4 channels	<ul style="list-style-type: none"> • 8-bit up-counter (external event count capability) • Two time constant registers • Two channels can be connected
Programmable timing pattern controller (TPC)	<ul style="list-style-type: none"> • Maximum 16-bit pulse output, using 16-bit timer as time base • Up to four 4-bit pulse output groups (or one 16-bit group, or two 8-bit groups) • Non-overlap mode available • Output data can be transferred by DMAC
Watchdog timer (WDT), 1 channel	<ul style="list-style-type: none"> • Internal reset signal can be generated by overflow • Reset signal can be output externally • Usable as an interval timer
Serial communication interface (SCI), 3 channels	<ul style="list-style-type: none"> • Selection of asynchronous or synchronous mode • Full duplex: can transmit and receive simultaneously • On-chip baud-rate generator • Smart card interface functions added
A/D converter	<ul style="list-style-type: none"> • Resolution: 10 bits • Eight channels, with selection of single or scan mode • Variable analog conversion voltage range • Sample-and-hold function • A/D conversion can be started by an external trigger or 8-bit timer compare-match • DMAC can be activated by an A/D conversion end interrupt
D/A converter	<ul style="list-style-type: none"> • Resolution: 8 bits • Two channels • D/A outputs can be sustained in software standby mode
I/O ports	<ul style="list-style-type: none"> • 35 input/output pins • 12 input-only pins

Feature	Description				
Operating modes	Four MCU operating modes				
	Mode	Address Space	Address Pins	Initial Bus Width	Max. Bus Width
	Mode 1	1 Mbyte	A ₁₉ to A ₀	8 bits	16 bits
	Mode 2	1 Mbyte	A ₁₉ to A ₀	16 bits	16 bits
	Mode 3	16 Mbytes	A ₂₃ to A ₀	8 bits	16 bits
Mode 4	16 Mbytes	A ₂₃ to A ₀	16 bits	16 bits	
Power-down state	<ul style="list-style-type: none"> • Sleep mode • Software standby mode • Hardware standby mode • Module standby function • Programmable system clock frequency division 				
Other features	<ul style="list-style-type: none"> • On-chip clock pulse generator 				
Product lineup	Product Name		Model	Package	
	H8/3007	5 V ± 10% (5 V)	HD6413007F	100-pin QFP (FP-100B)	
			HD6413007TE	100-pin TQFP (TFP-100B)	
			HD6413007FP	100-pin QFP (FP-100A)	
		2.7 to 5.5 V (Low voltage)	HD6413007VF	100-pin QFP (FP-100B)	
			HD6413007VTE	100-pin TQFP (TFP-100B)	
			HD6413007VFP	100-pin QFP (FP-100A)	
	H8/3006	5 V ± 10% (5 V)	HD6413006F	100-pin QFP (FP-100B)	
			HD6413006TE	100-pin TQFP (TFP-100B)	
			HD6413006FP	100-pin QFP (FP-100A)	
		2.7 to 5.5 V (Low voltage)	HD6413006VF	100-pin QFP (FP-100B)	
			HD6413006VTE	100-pin TQFP (TFP-100B)	
			HD6413006VFP	100-pin QFP (FP-100A)	

1.2 Internal Block Diagram

Figure 1-1 shows an internal block diagram.

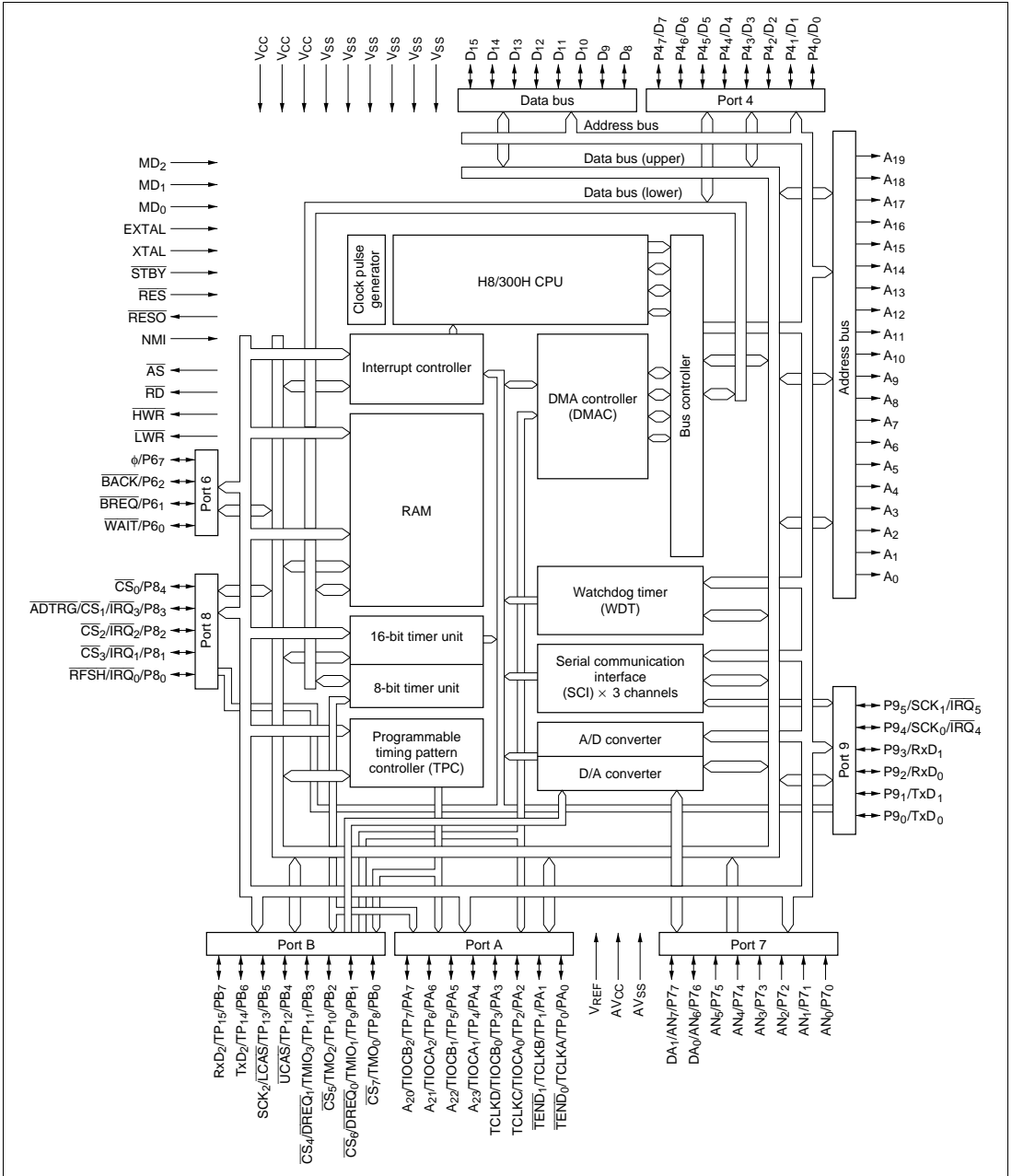

Figure 1-1 Block Diagram

1.3 Pin Description

1.3.1 Pin Arrangement

The pin arrangement of the H8/3006, H8/3007 FP-100B and TFP-100B packages is shown in figure 1-2, and that of the FP-100A package in figure 1-3.

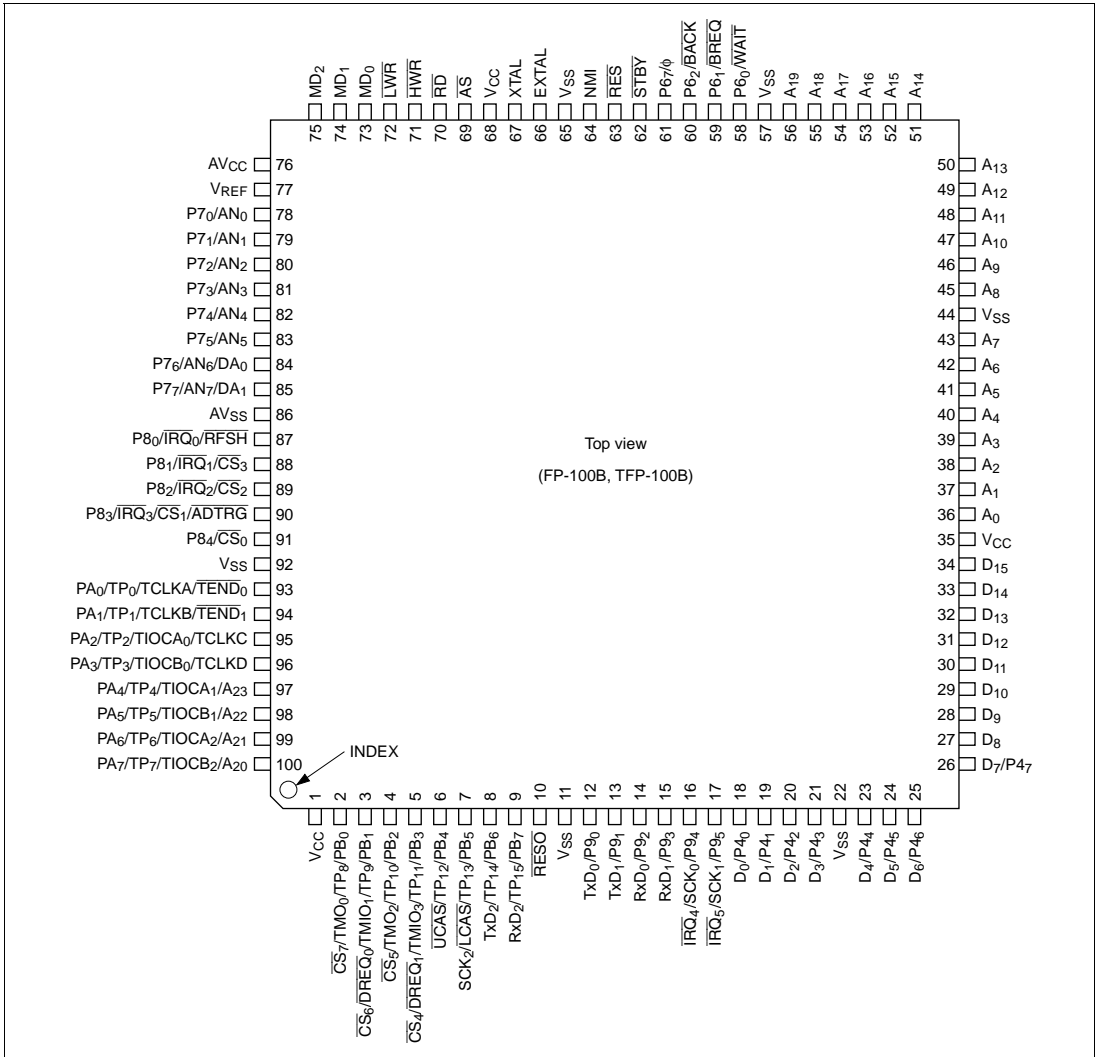

Figure 1-2 Pin Arrangement (FP-100B or TFP-100B, Top View)

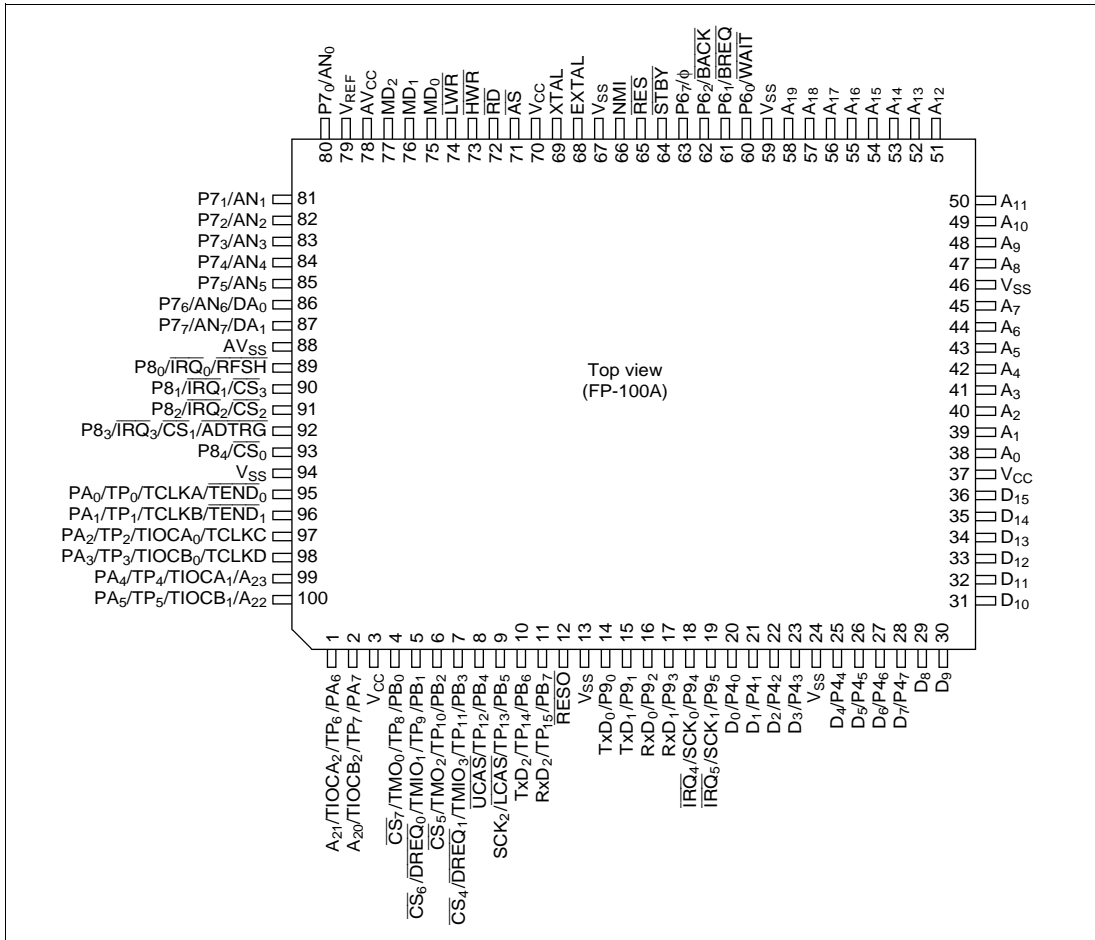

Figure 1-3 Pin Arrangement (FP-100A, Top View)

1.3.2 Pin Functions

Table 1-2 summarizes the pin functions.

Table 1-2 Pin Functions

Type	Symbol	Pin No.			Name and Function																																				
		FP-100B	TFP-100B	FP-100A I/O																																					
Power	V_{CC}	1, 35, 68	3, 37, 70	Input	Power: For connection to the power supply. Connect all V_{CC} pins to the system power supply.																																				
	V_{SS}	11, 22, 44, 57, 65, 92	13, 24, 46, 59, 67, 94	Input	Ground: For connection to ground (0 V). Connect all V_{SS} pins to the 0-V system power supply.																																				
Clock	XTAL	67	69	Input	For connection to a crystal resonator. For examples of crystal resonator and external clock input, see section 18, Clock Pulse Generator.																																				
	EXTAL	66	68	Input	For connection to a crystal resonator or input of an external clock signal. For examples of crystal resonator and external clock input, see section 18, Clock Pulse Generator.																																				
	ϕ	61	63	Output	System clock: Supplies the system clock to external devices.																																				
Operating mode control	MD_2 to MD_0	75 to 73	77 to 75	Input	Mode 2 to mode 0: For setting the operating mode, as follows. Inputs at these pins must not be changed during operation.																																				
		<table border="1"> <thead> <tr> <th>MD_2</th> <th>MD_1</th> <th>MD_0</th> <th>Operating Mode</th> </tr> </thead> <tbody> <tr> <td>0</td> <td>0</td> <td>0</td> <td>—</td> </tr> <tr> <td>0</td> <td>0</td> <td>1</td> <td>Mode 1</td> </tr> <tr> <td>0</td> <td>1</td> <td>0</td> <td>Mode 2</td> </tr> <tr> <td>0</td> <td>1</td> <td>1</td> <td>Mode 3</td> </tr> <tr> <td>1</td> <td>0</td> <td>0</td> <td>Mode 4</td> </tr> <tr> <td>1</td> <td>0</td> <td>1</td> <td>—</td> </tr> <tr> <td>1</td> <td>1</td> <td>0</td> <td>—</td> </tr> <tr> <td>1</td> <td>1</td> <td>1</td> <td>—</td> </tr> </tbody> </table>				MD_2	MD_1	MD_0	Operating Mode	0	0	0	—	0	0	1	Mode 1	0	1	0	Mode 2	0	1	1	Mode 3	1	0	0	Mode 4	1	0	1	—	1	1	0	—	1	1	1	—
		MD_2	MD_1	MD_0	Operating Mode																																				
		0	0	0	—																																				
		0	0	1	Mode 1																																				
		0	1	0	Mode 2																																				
		0	1	1	Mode 3																																				
		1	0	0	Mode 4																																				
		1	0	1	—																																				
		1	1	0	—																																				
1	1	1	—																																						
<table border="1"> <thead> <tr> <th>MD_2</th> <th>MD_1</th> <th>MD_0</th> <th>Operating Mode</th> </tr> </thead> <tbody> <tr> <td>0</td> <td>0</td> <td>0</td> <td>—</td> </tr> <tr> <td>0</td> <td>0</td> <td>1</td> <td>Mode 1</td> </tr> <tr> <td>0</td> <td>1</td> <td>0</td> <td>Mode 2</td> </tr> <tr> <td>0</td> <td>1</td> <td>1</td> <td>Mode 3</td> </tr> <tr> <td>1</td> <td>0</td> <td>0</td> <td>Mode 4</td> </tr> <tr> <td>1</td> <td>0</td> <td>1</td> <td>—</td> </tr> <tr> <td>1</td> <td>1</td> <td>0</td> <td>—</td> </tr> <tr> <td>1</td> <td>1</td> <td>1</td> <td>—</td> </tr> </tbody> </table>				MD_2	MD_1	MD_0	Operating Mode	0	0	0	—	0	0	1	Mode 1	0	1	0	Mode 2	0	1	1	Mode 3	1	0	0	Mode 4	1	0	1	—	1	1	0	—	1	1	1	—		
MD_2	MD_1	MD_0	Operating Mode																																						
0	0	0	—																																						
0	0	1	Mode 1																																						
0	1	0	Mode 2																																						
0	1	1	Mode 3																																						
1	0	0	Mode 4																																						
1	0	1	—																																						
1	1	0	—																																						
1	1	1	—																																						
<table border="1"> <thead> <tr> <th>MD_2</th> <th>MD_1</th> <th>MD_0</th> <th>Operating Mode</th> </tr> </thead> <tbody> <tr> <td>0</td> <td>0</td> <td>0</td> <td>—</td> </tr> <tr> <td>0</td> <td>0</td> <td>1</td> <td>Mode 1</td> </tr> <tr> <td>0</td> <td>1</td> <td>0</td> <td>Mode 2</td> </tr> <tr> <td>0</td> <td>1</td> <td>1</td> <td>Mode 3</td> </tr> <tr> <td>1</td> <td>0</td> <td>0</td> <td>Mode 4</td> </tr> <tr> <td>1</td> <td>0</td> <td>1</td> <td>—</td> </tr> <tr> <td>1</td> <td>1</td> <td>0</td> <td>—</td> </tr> <tr> <td>1</td> <td>1</td> <td>1</td> <td>—</td> </tr> </tbody> </table>				MD_2	MD_1	MD_0	Operating Mode	0	0	0	—	0	0	1	Mode 1	0	1	0	Mode 2	0	1	1	Mode 3	1	0	0	Mode 4	1	0	1	—	1	1	0	—	1	1	1	—		
MD_2	MD_1	MD_0	Operating Mode																																						
0	0	0	—																																						
0	0	1	Mode 1																																						
0	1	0	Mode 2																																						
0	1	1	Mode 3																																						
1	0	0	Mode 4																																						
1	0	1	—																																						
1	1	0	—																																						
1	1	1	—																																						
<table border="1"> <thead> <tr> <th>MD_2</th> <th>MD_1</th> <th>MD_0</th> <th>Operating Mode</th> </tr> </thead> <tbody> <tr> <td>0</td> <td>0</td> <td>0</td> <td>—</td> </tr> <tr> <td>0</td> <td>0</td> <td>1</td> <td>Mode 1</td> </tr> <tr> <td>0</td> <td>1</td> <td>0</td> <td>Mode 2</td> </tr> <tr> <td>0</td> <td>1</td> <td>1</td> <td>Mode 3</td> </tr> <tr> <td>1</td> <td>0</td> <td>0</td> <td>Mode 4</td> </tr> <tr> <td>1</td> <td>0</td> <td>1</td> <td>—</td> </tr> <tr> <td>1</td> <td>1</td> <td>0</td> <td>—</td> </tr> <tr> <td>1</td> <td>1</td> <td>1</td> <td>—</td> </tr> </tbody> </table>				MD_2	MD_1	MD_0	Operating Mode	0	0	0	—	0	0	1	Mode 1	0	1	0	Mode 2	0	1	1	Mode 3	1	0	0	Mode 4	1	0	1	—	1	1	0	—	1	1	1	—		
MD_2	MD_1	MD_0	Operating Mode																																						
0	0	0	—																																						
0	0	1	Mode 1																																						
0	1	0	Mode 2																																						
0	1	1	Mode 3																																						
1	0	0	Mode 4																																						
1	0	1	—																																						
1	1	0	—																																						
1	1	1	—																																						
<table border="1"> <thead> <tr> <th>MD_2</th> <th>MD_1</th> <th>MD_0</th> <th>Operating Mode</th> </tr> </thead> <tbody> <tr> <td>0</td> <td>0</td> <td>0</td> <td>—</td> </tr> <tr> <td>0</td> <td>0</td> <td>1</td> <td>Mode 1</td> </tr> <tr> <td>0</td> <td>1</td> <td>0</td> <td>Mode 2</td> </tr> <tr> <td>0</td> <td>1</td> <td>1</td> <td>Mode 3</td> </tr> <tr> <td>1</td> <td>0</td> <td>0</td> <td>Mode 4</td> </tr> <tr> <td>1</td> <td>0</td> <td>1</td> <td>—</td> </tr> <tr> <td>1</td> <td>1</td> <td>0</td> <td>—</td> </tr> <tr> <td>1</td> <td>1</td> <td>1</td> <td>—</td> </tr> </tbody> </table>				MD_2	MD_1	MD_0	Operating Mode	0	0	0	—	0	0	1	Mode 1	0	1	0	Mode 2	0	1	1	Mode 3	1	0	0	Mode 4	1	0	1	—	1	1	0	—	1	1	1	—		
MD_2	MD_1	MD_0	Operating Mode																																						
0	0	0	—																																						
0	0	1	Mode 1																																						
0	1	0	Mode 2																																						
0	1	1	Mode 3																																						
1	0	0	Mode 4																																						
1	0	1	—																																						
1	1	0	—																																						
1	1	1	—																																						
<table border="1"> <thead> <tr> <th>MD_2</th> <th>MD_1</th> <th>MD_0</th> <th>Operating Mode</th> </tr> </thead> <tbody> <tr> <td>0</td> <td>0</td> <td>0</td> <td>—</td> </tr> <tr> <td>0</td> <td>0</td> <td>1</td> <td>Mode 1</td> </tr> <tr> <td>0</td> <td>1</td> <td>0</td> <td>Mode 2</td> </tr> <tr> <td>0</td> <td>1</td> <td>1</td> <td>Mode 3</td> </tr> <tr> <td>1</td> <td>0</td> <td>0</td> <td>Mode 4</td> </tr> <tr> <td>1</td> <td>0</td> <td>1</td> <td>—</td> </tr> <tr> <td>1</td> <td>1</td> <td>0</td> <td>—</td> </tr> <tr> <td>1</td> <td>1</td> <td>1</td> <td>—</td> </tr> </tbody> </table>				MD_2	MD_1	MD_0	Operating Mode	0	0	0	—	0	0	1	Mode 1	0	1	0	Mode 2	0	1	1	Mode 3	1	0	0	Mode 4	1	0	1	—	1	1	0	—	1	1	1	—		
MD_2	MD_1	MD_0	Operating Mode																																						
0	0	0	—																																						
0	0	1	Mode 1																																						
0	1	0	Mode 2																																						
0	1	1	Mode 3																																						
1	0	0	Mode 4																																						
1	0	1	—																																						
1	1	0	—																																						
1	1	1	—																																						

Type	Symbol	Pin No.		I/O	Name and Function
		FP-100B	FP-100A		
System control	$\overline{\text{RES}}$	63	65	Input	Reset input: When driven low, this pin resets the chip
	$\overline{\text{RESO}}$	10	12	Output	Reset output: Outputs the reset signal generated by the watchdog timer to external devices
	$\overline{\text{STBY}}$	62	64	Input	Standby: When driven low, this pin forces a transition to hardware standby mode
	$\overline{\text{BREQ}}$	59	61	Input	Bus request: Used by an external bus master to request the bus right
	$\overline{\text{BACK}}$	60	62	Output	Bus request acknowledge: Indicates that the bus has been granted to an external bus master
Interrupts	NMI	64	66	Input	Nonmaskable interrupt: Requests a nonmaskable interrupt
	$\overline{\text{IRQ}}_5$ to $\overline{\text{IRQ}}_0$	17, 16, 90 to 87	19, 18, 92 to 89	Input	Interrupt request 5 to 0: Maskable interrupt request pins
Address bus	A_{23} to A_0	100 to 97, 56 to 45, 43 to 36	99, 100, 1, 2, 58 to 47, 45 to 38	Output	Address bus: Outputs address signals
Data bus	D_{15} to D_0	34 to 23, 21 to 18	36 to 25, 23 to 20	Input/output	Data bus: Bidirectional data bus
Bus control	$\overline{\text{CS}}_7$ to $\overline{\text{CS}}_0$	2 to 5, 88 to 91	4 to 7, 90 to 93	Output	Chip select: Select signals for areas 7 to 0
	$\overline{\text{AS}}$	69	71	Output	Address strobe: Goes low to indicate valid address output on the address bus
	$\overline{\text{RD}}$	70	72	Output	Read: Goes low to indicate reading from the external address space
	$\overline{\text{HWR}}$	71	73	Output	High write: Goes low to indicate writing to the external address space; indicates valid data on the upper data bus (D_{15} to D_8).
	$\overline{\text{LWR}}$	72	74	Output	Low write: Goes low to indicate writing to the external address space; indicates valid data on the lower data bus (D_7 to D_0).
	$\overline{\text{WAIT}}$	58	60	Input	Wait: Requests insertion of wait states in bus cycles during access to the external address space

Type	Symbol	Pin No.		I/O	Name and Function
		FP-100B	FP-100A		
DRAM interface	RFSH	87	89	Output	Refresh: Indicates a refresh cycle
	\overline{CS}_2 to \overline{CS}_5	89, 88, 5, 4	91, 90, 7, 6	Output	Row address strobe \overline{RAS}: Row address strobe signal for DRAM
	\overline{RD}	70	72	Output	Write enable \overline{WE}: Write enable signal for DRAM
	\overline{HWR} \overline{UCAS}	71 6	73 8	Output	Upper column address strobe \overline{UCAS}: Column address strobe signal for DRAM
	\overline{LWR} \overline{LCAS}	72 7	74 9	Output	Lower column address strobe \overline{LCAS}: Column address strobe signal for DRAM
DMA controller (DMAC)	\overline{DREQ}_1 , \overline{DREQ}_0	5, 3	7, 5	Input	DMA request 1 and 0: DMAC activation requests
	\overline{TEND}_1 , \overline{TEND}_0	94, 93	96, 95	Output	Transfer end 1 and 0: These signals indicate that the DMAC has ended a data transfer
16-bit timer	TCLKD to TCLKA	96 to 93	98 to 95	Input	Clock input D to A: External clock inputs
	TIOCA ₂ to TIOCA ₀	99, 97, 95	1, 99, 97	Input/output	Input capture/output compare A2 to A0: GRA2 to GRA0 output compare or input capture, or PWM output
	TIOCB ₂ to TIOCB ₀	100, 98, 96	2, 100, 98	Input/output	Input capture/output compare B2 to B0: GRB2 to GRB0 output compare or input capture, or PWM output
8-bit timer	TMO ₀ , TMO ₂	2, 4	4, 6	Output	Compare match output: Compare match output pins
	TMIO ₁ , TMIO ₃	3, 5	5, 7	Input/output	Input capture input/compare match output: Input capture input or compare match output pins
	TCLKD to TCLKA	96 to 93	98 to 95	Input	Counter external clock input: These pins input an external clock to the counters.

Pin No.

Type	Symbol	FP-100B		I/O	Name and Function
		TFP-100B	FP-100A		
Program- mable timing pattern controller (TPC)	TP ₁₅ to TP ₀	9 to 2, 100 to 93	11 to 4, 2, 1, 100 to 95	Output	TPC output 15 to 0: Pulse output
Serial communi- cation interface (SCI)	TxD ₂ to TxD ₀	8, 13, 12	10, 15, 14	Output	Transmit data (channels 0, 1, 2): SCI data output
	RxD ₂ to RxD ₀	9, 15, 14	11, 17, 16	Input	Receive data (channels 0, 1, 2): SCI data input
	SCK ₂ to SCK ₀	7, 17, 16	9, 19, 18	Input/ output	Serial clock (channels 0, 1, 2): SCI clock input/output
A/D converter	AN ₇ to AN ₀	85 to 78	87 to 80	Input	Analog 7 to 0: Analog input pins
	ADTRG	90	92	Input	A/D conversion external trigger input: External trigger input for starting A/D conversion
D/A converter	DA ₁ , DA ₀	85, 84	87, 86	Output	Analog output: Analog output from the D/A converter
A/D and D/A converters	AV _{CC}	76	78	Input	Power supply pin for the A/D and D/A converters. Connect to the system power supply when not using the A/D and D/A converters.
	AV _{SS}	86	88	Input	Ground pin for the A/D and D/A converters. Connect to system ground (0 V).
	V _{REF}	77	79	Input	Reference voltage input pin for the A/D and D/A converters. Connect to the system power supply when not using the A/D and D/A converters.

Type	Symbol	Pin No.		I/O	Name and Function
		FP-100B	TFP-100B		
I/O ports	P4 ₇ to P4 ₀	26 to 23, 21 to 18	28 to 25, 23 to 20	Input/ output	Port 4: Eight input/output pins. The direction of each pin can be selected in the port 4 data direction register (P4DDR).
	P6 ₇ , P6 ₂ to P6 ₀	61 to 58	63 to 60	Input/ output	Port 6: Four input/output pins. The direction of each pin can be selected in the port 6 data direction register (P6DDR).
	P7 ₇ to P7 ₀	85 to 78	87 to 80	Input	Port 7: Eight input pins
	P8 ₄ to P8 ₀	91 to 87	93 to 89	Input/ output	Port 8: Five input/output pins. The direction of each pin can be selected in the port 8 data direction register (P8DDR).
	P9 ₅ to P9 ₀	17 to 12	19 to 14	Input/ output	Port 9: Six input/output pins. The direction of each pin can be selected in the port 9 data direction register (P9DDR).
	PA ₇ to PA ₀	100 to 93	2, 1, 100 to 95	Input/ output	Port A: Eight input/output pins. The direction of each pin can be selected in the port A data direction register (PADDR).
	PB ₇ to PB ₀	9 to 2	11 to 4	Input/ output	Port B: Eight input/output pins. The direction of each pin can be selected in the port B data direction register (PBDDR).

1.3.3 Pin Assignments in Each Mode

Table 1-3 lists the pin assignments in each mode.

Table 1-3 Pin Assignments in Each Mode (FP-100B or TFP-100B, FP-100A)

Pin No.		Pin Name			
FP-100B TFP-100B	FP-100A	Mode 1	Mode 2	Mode 3	Mode 4
1	3	V _{CC}	V _{CC}	V _{CC}	V _{CC}
2	4	PB ₀ /TP ₈ /TMO ₀ / CS ₇	PB ₀ /TP ₈ /TMO ₀ / CS ₇	PB ₀ /TP ₈ /TMO ₀ / CS ₇	PB ₀ /TP ₈ /TMO ₀ / CS ₇
3	5	PB ₁ /TP ₉ /TMIO ₁ / DREQ ₀ /CS ₆	PB ₁ /TP ₉ /TMIO ₁ / DREQ ₀ /CS ₆	PB ₁ /TP ₉ /TMIO ₁ / DREQ ₀ /CS ₆	PB ₁ /TP ₉ /TMIO ₁ / DREQ ₀ /CS ₆
4	6	PB ₂ /TP ₁₀ /TMO ₂ / CS ₅	PB ₂ /TP ₁₀ /TMO ₂ / CS ₅	PB ₂ /TP ₁₀ /TMO ₂ / CS ₅	PB ₂ /TP ₁₀ /TMO ₂ / CS ₅
5	7	PB ₃ /TP ₁₁ /TMIO ₃ / DREQ ₁ /CS ₄	PB ₃ /TP ₁₁ /TMIO ₃ / DREQ ₁ /CS ₄	PB ₃ /TP ₁₁ /TMIO ₃ / DREQ ₁ /CS ₄	PB ₃ /TP ₁₁ /TMIO ₃ / DREQ ₁ /CS ₄
6	8	PB ₄ /TP ₁₂ /UCAS	PB ₄ /TP ₁₂ /UCAS	PB ₄ /TP ₁₂ /UCAS	PB ₄ /TP ₁₂ /UCAS
7	9	PB ₅ /TP ₁₃ /LCAS/ SCK ₂	PB ₅ /TP ₁₃ /LCAS/ SCK ₂	PB ₅ /TP ₁₃ /LCAS/ SCK ₂	PB ₅ /TP ₁₃ /LCAS/ SCK ₂
8	10	PB ₆ /TP ₁₄ /TxD ₂	PB ₆ /TP ₁₄ /TxD ₂	PB ₆ /TP ₁₄ /TxD ₂	PB ₆ /TP ₁₄ /TxD ₂
9	11	PB ₇ /TP ₁₅ /RxD ₂	PB ₇ /TP ₁₅ /RxD ₂	PB ₇ /TP ₁₅ /RxD ₂	PB ₇ /TP ₁₅ /RxD ₂
10	12	RESO	RESO	RESO	RESO
11	13	V _{SS}	V _{SS}	V _{SS}	V _{SS}
12	14	P9 ₀ /TxD ₀	P9 ₀ /TxD ₀	P9 ₀ /TxD ₀	P9 ₀ /TxD ₀
13	15	P9 ₁ /TxD ₁	P9 ₁ /TxD ₁	P9 ₁ /TxD ₁	P9 ₁ /TxD ₁
14	16	P9 ₂ /RxD ₀	P9 ₂ /RxD ₀	P9 ₂ /RxD ₀	P9 ₂ /RxD ₀
15	17	P9 ₃ /RxD ₁	P9 ₃ /RxD ₁	P9 ₃ /RxD ₁	P9 ₃ /RxD ₁
16	18	P9 ₄ /IRQ ₄ /SCK ₀	P9 ₄ /IRQ ₄ /SCK ₀	P9 ₄ /IRQ ₄ /SCK ₀	P9 ₄ /IRQ ₄ /SCK ₀
17	19	P9 ₅ /IRQ ₅ /SCK ₁	P9 ₅ /IRQ ₅ /SCK ₁	P9 ₅ /IRQ ₅ /SCK ₁	P9 ₅ /IRQ ₅ /SCK ₁
18	20	P4 ₀ /D ₀ ^{*1}	P4 ₀ /D ₀ ^{*2}	P4 ₀ /D ₀ ^{*1}	P4 ₀ /D ₀ ^{*2}
19	21	P4 ₁ /D ₁ ^{*1}	P4 ₁ /D ₁ ^{*2}	P4 ₁ /D ₁ ^{*1}	P4 ₁ /D ₁ ^{*2}
20	22	P4 ₂ /D ₂ ^{*1}	P4 ₂ /D ₂ ^{*2}	P4 ₂ /D ₂ ^{*1}	P4 ₂ /D ₂ ^{*2}
21	23	P4 ₃ /D ₃ ^{*1}	P4 ₃ /D ₃ ^{*2}	P4 ₃ /D ₃ ^{*1}	P4 ₃ /D ₃ ^{*2}
22	24	V _{SS}	V _{SS}	V _{SS}	V _{SS}
23	25	P4 ₄ /D ₄ ^{*1}	P4 ₄ /D ₄ ^{*2}	P4 ₄ /D ₄ ^{*1}	P4 ₄ /D ₄ ^{*2}

Pin No.		Pin Name			
FP-100B	FP-100A	Mode 1	Mode 2	Mode 3	Mode 4
24	26	P4 ₅ /D ₅ * ¹	P4 ₅ /D ₅ * ²	P4 ₅ /D ₅ * ¹	P4 ₅ /D ₅ * ²
25	27	P4 ₆ /D ₆ * ¹	P4 ₆ /D ₆ * ²	P4 ₆ /D ₆ * ¹	P4 ₆ /D ₆ * ²
26	28	P4 ₇ /D ₇ * ¹	P4 ₇ /D ₇ * ²	P4 ₇ /D ₇ * ¹	P4 ₇ /D ₇ * ²
27	29	D ₈	D ₈	D ₈	D ₈
28	30	D ₉	D ₉	D ₉	D ₉
29	31	D ₁₀	D ₁₀	D ₁₀	D ₁₀
30	32	D ₁₁	D ₁₁	D ₁₁	D ₁₁
31	33	D ₁₂	D ₁₂	D ₁₂	D ₁₂
32	34	D ₁₃	D ₁₃	D ₁₃	D ₁₃
33	35	D ₁₄	D ₁₄	D ₁₄	D ₁₄
34	36	D ₁₅	D ₁₅	D ₁₅	D ₁₅
35	37	V _{CC}	V _{CC}	V _{CC}	V _{CC}
36	38	A ₀	A ₀	A ₀	A ₀
37	39	A ₁	A ₁	A ₁	A ₁
38	40	A ₂	A ₂	A ₂	A ₂
39	41	A ₃	A ₃	A ₃	A ₃
40	42	A ₄	A ₄	A ₄	A ₄
41	43	A ₅	A ₅	A ₅	A ₅
42	44	A ₆	A ₆	A ₆	A ₆
43	45	A ₇	A ₇	A ₇	A ₇
44	46	V _{SS}	V _{SS}	V _{SS}	V _{SS}
45	47	A ₈	A ₈	A ₈	A ₈
46	48	A ₉	A ₉	A ₉	A ₉
47	49	A ₁₀	A ₁₀	A ₁₀	A ₁₀
48	50	A ₁₁	A ₁₁	A ₁₁	A ₁₁
49	51	A ₁₂	A ₁₂	A ₁₂	A ₁₂
50	52	A ₁₃	A ₁₃	A ₁₃	A ₁₃
51	53	A ₁₄	A ₁₄	A ₁₄	A ₁₄
52	54	A ₁₅	A ₁₅	A ₁₅	A ₁₅
53	55	A ₁₆	A ₁₆	A ₁₆	A ₁₆
54	56	A ₁₇	A ₁₇	A ₁₇	A ₁₇

Pin No.		Pin Name			
FP-100B TFP-100B	FP-100A	Mode 1	Mode 2	Mode 3	Mode 4
55	57	A ₁₈	A ₁₈	A ₁₈	A ₁₈
56	58	A ₁₉	A ₁₉	A ₁₉	A ₁₉
57	59	V _{SS}	V _{SS}	V _{SS}	V _{SS}
58	60	P6 ₀ /WAIT	P6 ₀ /WAIT	P6 ₀ /WAIT	P6 ₀ /WAIT
59	61	P6 ₁ /BREQ	P6 ₁ /BREQ	P6 ₁ /BREQ	P6 ₁ /BREQ
60	62	P6 ₂ /BACK	P6 ₂ /BACK	P6 ₂ /BACK	P6 ₂ /BACK
61	63	P6 ₇ /φ	P6 ₇ /φ	P6 ₇ /φ	P6 ₇ /φ
62	64	STBY	STBY	STBY	STBY
63	65	RES	RES	RES	RES
64	66	NMI	NMI	NMI	NMI
65	67	V _{SS}	V _{SS}	V _{SS}	V _{SS}
66	68	EXTAL	EXTAL	EXTAL	EXTAL
67	69	XTAL	XTAL	XTAL	XTAL
68	70	V _{CC}	V _{CC}	V _{CC}	V _{CC}
69	71	AS	AS	AS	AS
70	72	RD	RD	RD	RD
71	73	HWR	HWR	HWR	HWR
72	74	LWR	LWR	LWR	LWR
73	75	MD ₀	MD ₀	MD ₀	MD ₀
74	76	MD ₁	MD ₁	MD ₁	MD ₁
75	77	MD ₂	MD ₂	MD ₂	MD ₂
76	78	AV _{CC}	AV _{CC}	AV _{CC}	AV _{CC}
77	79	V _{REF}	V _{REF}	V _{REF}	V _{REF}
78	80	P7 ₀ /AN ₀	P7 ₀ /AN ₀	P7 ₀ /AN ₀	P7 ₀ /AN ₀
79	81	P7 ₁ /AN ₁	P7 ₁ /AN ₁	P7 ₁ /AN ₁	P7 ₁ /AN ₁
80	82	P7 ₂ /AN ₂	P7 ₂ /AN ₂	P7 ₂ /AN ₂	P7 ₂ /AN ₂
81	83	P7 ₃ /AN ₃	P7 ₃ /AN ₃	P7 ₃ /AN ₃	P7 ₃ /AN ₃
82	84	P7 ₄ /AN ₄	P7 ₄ /AN ₄	P7 ₄ /AN ₄	P7 ₄ /AN ₄
83	85	P7 ₅ /AN ₅	P7 ₅ /AN ₅	P7 ₅ /AN ₅	P7 ₅ /AN ₅
84	86	P7 ₆ /AN ₆ /DA ₀	P7 ₆ /AN ₆ /DA ₀	P7 ₆ /AN ₆ /DA ₀	P7 ₆ /AN ₆ /DA ₀
85	87	P7 ₇ /AN ₇ /DA ₁	P7 ₇ /AN ₇ /DA ₁	P7 ₇ /AN ₇ /DA ₁	P7 ₇ /AN ₇ /DA ₁

Pin No.		Pin Name			
FP-100B	FP-100A	Mode 1	Mode 2	Mode 3	Mode 4
86	88	AV _{SS}	AV _{SS}	AV _{SS}	AV _{SS}
87	89	P8 ₀ /IRQ ₀ /RFSH	P8 ₀ /IRQ ₀ /RFSH	P8 ₀ /IRQ ₀ /RFSH	P8 ₀ /IRQ ₀ /RFSH
88	90	P8 ₁ /IRQ ₁ /CS ₃	P8 ₁ /IRQ ₁ /CS ₃	P8 ₁ /IRQ ₁ /CS ₃	P8 ₁ /IRQ ₁ /CS ₃
89	91	P8 ₂ /IRQ ₂ /CS ₂	P8 ₂ /IRQ ₂ /CS ₂	P8 ₂ /IRQ ₂ /CS ₂	P8 ₂ /IRQ ₂ /CS ₂
90	92	P8 ₃ /IRQ ₃ /CS ₁ /ADTRG	P8 ₃ /IRQ ₃ /CS ₁ /ADTRG	P8 ₃ /IRQ ₃ /CS ₁ /ADTRG	P8 ₃ /IRQ ₃ /CS ₁ /ADTRG
91	93	P8 ₄ /CS ₀	P8 ₄ /CS ₀	P8 ₄ /CS ₀	P8 ₄ /CS ₀
92	94	V _{SS}	V _{SS}	V _{SS}	V _{SS}
93	95	PA ₀ /TP ₀ /TCLKA/ TEND ₀	PA ₀ /TP ₀ /TCLKA/ TEND ₀	PA ₀ /TP ₀ /TCLKA/ TEND ₀	PA ₀ /TP ₀ /TCLKA/ TEND ₀
94	96	PA ₁ /TP ₁ /TCLKB/ TEND ₁	PA ₁ /TP ₁ /TCLKB/ TEND ₁	PA ₁ /TP ₁ /TCLKB/ TEND ₁	PA ₁ /TP ₁ /TCLKB/ TEND ₁
95	97	PA ₂ /TP ₂ /TIOCA ₀ / TCLKC	PA ₂ /TP ₂ /TIOCA ₀ / TCLKC	PA ₂ /TP ₂ /TIOCA ₀ / TCLKC	PA ₂ /TP ₂ /TIOCA ₀ / TCLKC
96	98	PA ₃ /TP ₃ /TIOCB ₀ / TCLKD	PA ₃ /TP ₃ /TIOCB ₀ / TCLKD	PA ₃ /TP ₃ /TIOCB ₀ / TCLKD	PA ₃ /TP ₃ /TIOCB ₀ / TCLKD
97	99	PA ₄ /TP ₄ /TIOCA ₁	PA ₄ /TP ₄ /TIOCA ₁	PA ₄ /TP ₄ /TIOCA ₁ / A ₂₃	PA ₄ /TP ₄ /TIOCA ₁ / A ₂₃
98	100	PA ₅ /TP ₅ /TIOCB ₁	PA ₅ /TP ₅ /TIOCB ₁	PA ₅ /TP ₅ /TIOCB ₁ / A ₂₂	PA ₅ /TP ₅ /TIOCB ₁ / A ₂₂
99	1	PA ₆ /TP ₆ /TIOCA ₂	PA ₆ /TP ₆ /TIOCA ₂	PA ₆ /TP ₆ /TIOCA ₂ / A ₂₁	PA ₆ /TP ₆ /TIOCA ₂ / A ₂₁
100	2	PA ₇ /TP ₇ /TIOCB ₂	PA ₇ /TP ₇ /TIOCB ₂	A ₂₀	A ₂₀

Notes: 1. In modes 1 and 3, the P4₀ to P4₇ functions of pins P4₀/D₀ to P4₇/D₇ are selected after a reset, but they can be changed by software.

2. In modes 2 and 4, the D₀ to D₇ functions of pins P4₀/D₀ to P4₇/D₇ are selected after a reset, but they can be changed by software.

Section 2 CPU

2.1 Overview

The H8/300H CPU is a high-speed central processing unit with an internal 32-bit architecture that is upward-compatible with the H8/300 CPU. The H8/300H CPU has sixteen 16-bit general registers, can address a 16-Mbyte linear address space, and is ideal for realtime control.

2.1.1 Features

The H8/300H CPU has the following features.

- Upward compatibility with H8/300 CPU
Can execute H8/300 Series object programs
- General-register architecture
Sixteen 16-bit general registers (also usable as sixteen 8-bit registers or eight 32-bit registers)
- Sixty-two basic instructions
 - 8/16/32-bit arithmetic and logic instructions
 - Multiply and divide instructions
 - Powerful bit-manipulation instructions
- Eight addressing modes
 - Register direct [Rn]
 - Register indirect [@ERn]
 - Register indirect with displacement [@(d:16, ERn) or @(d:24, ERn)]
 - Register indirect with post-increment or pre-decrement [@ERn+ or @-ERn]
 - Absolute address [@aa:8, @aa:16, or @aa:24]
 - Immediate [#xx:8, #xx:16, or #xx:32]
 - Program-counter relative [@(d:8, PC) or @(d:16, PC)]
 - Memory indirect [@@aa:8]
- 16-Mbyte linear address space

- High-speed operation
 - All frequently-used instructions execute in two to four states
 - Maximum clock frequency: 20 MHz
 - 8/16/32-bit register-register add/subtract: 100 ns
 - 8×8 -bit register-register multiply: 700 ns
 - $16 \div 8$ -bit register-register divide: 700 ns
 - 16×16 -bit register-register multiply: 1.1 μ s
 - $32 \div 16$ -bit register-register divide: 1.1 μ s
- Two CPU operating modes
 - Normal mode (not available in the H8/3006 and H8/3007)
 - Advanced mode
- Low-power mode
 - Transition to power-down state by SLEEP instruction

2.1.2 Differences from H8/300 CPU

In comparison to the H8/300 CPU, the H8/300H has the following enhancements.

- More general registers
 - Eight 16-bit registers have been added.
- Expanded address space
 - Advanced mode supports a maximum 16-Mbyte address space.
 - Normal mode supports the same 64-kbyte address space as the H8/300 CPU.
- Enhanced addressing
 - The addressing modes have been enhanced to make effective use of the 16-Mbyte address space.
- Enhanced instructions
 - Data transfer, arithmetic, and logic instructions can operate on 32-bit data.
 - Signed multiply/divide instructions and other instructions have been added.

2.2 CPU Operating Modes

The H8/300H CPU has two operating modes: normal and advanced. Normal mode supports a maximum 64-kbyte address space. Advanced mode supports up to 16 Mbytes.

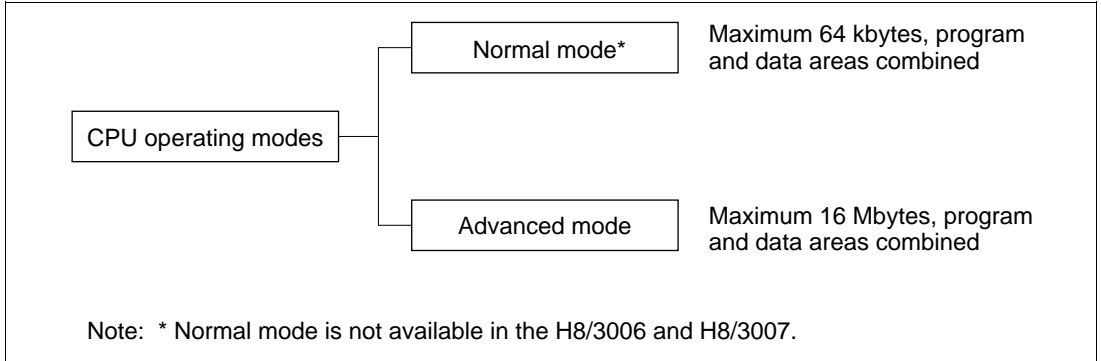

Figure 2-1 CPU Operating Modes

2.3 Address Space

Figure 2-2 shows a simple memory map for the H8/3006 and H8/3007. The H8/300H CPU can address a linear address space with a maximum size of 64 kbytes in normal mode, and 16 Mbytes in advanced mode. For further details see section 3.6, Memory Map in Each Operating Mode.

The 1-Mbyte operating modes use 20-bit addressing. The upper 4 bits of effective addresses are ignored.

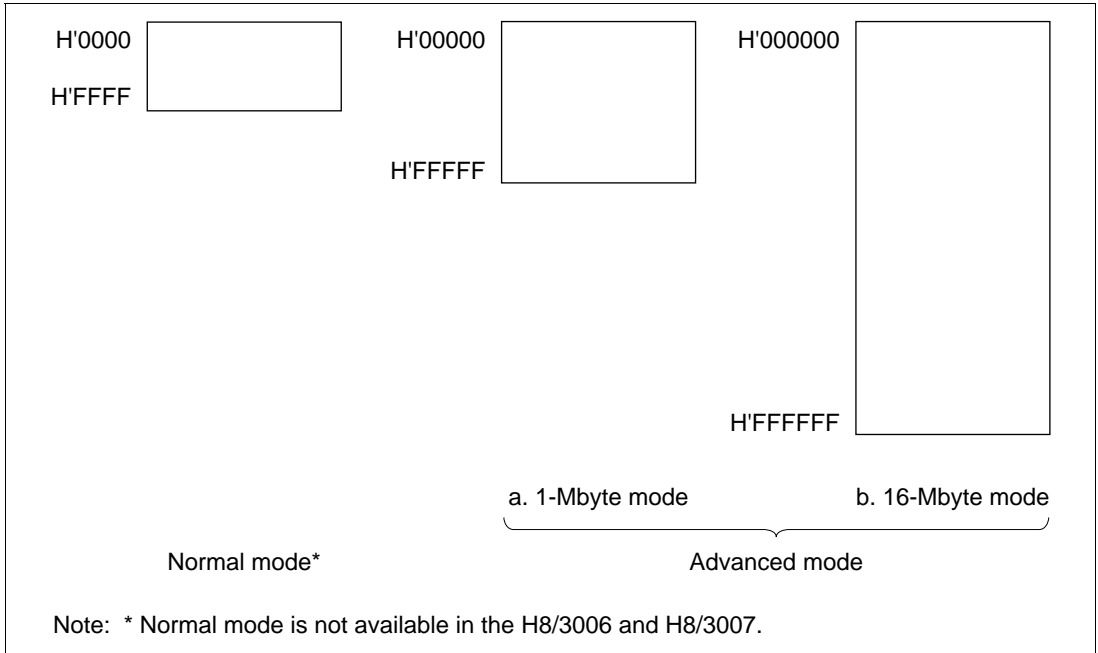

Figure 2-2 Memory Map

2.4 Register Configuration

2.4.1 Overview

The H8/300H CPU has the internal registers shown in figure 2-3. There are two types of registers: general registers and control registers.

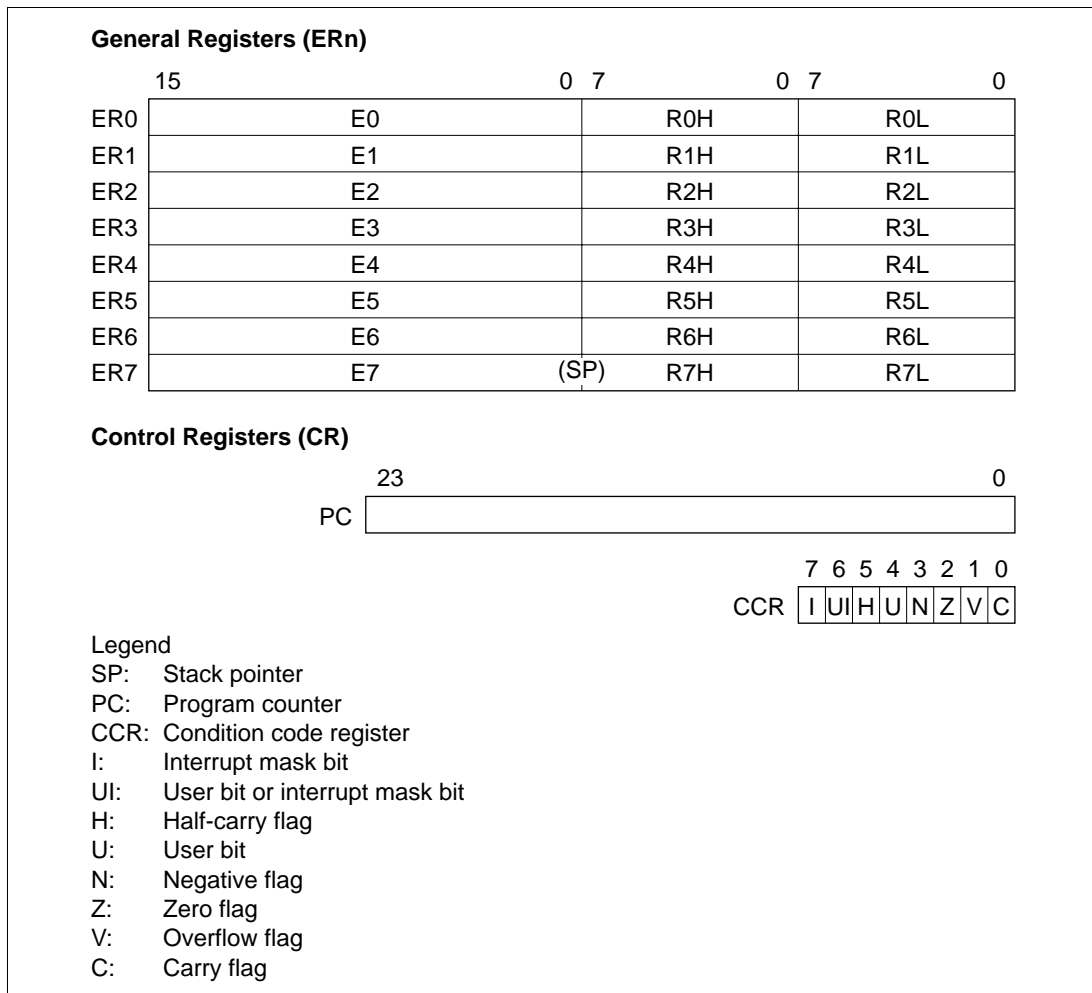

Figure 2-3 CPU Registers

2.4.2 General Registers

The H8/300H CPU has eight 32-bit general registers. These general registers are all functionally alike and can be used without distinction between data registers and address registers. When a general register is used as a data register, it can be accessed as a 32-bit, 16-bit, or 8-bit register. When the general registers are used as 32-bit registers or as address registers, they are designated by the letters ER (ER0 to ER7).

The ER registers divide into 16-bit general registers designated by the letters E (E0 to E7) and R (R0 to R7). These registers are functionally equivalent, providing a maximum sixteen 16-bit registers. The E registers (E0 to E7) are also referred to as extended registers.

The R registers divide into 8-bit general registers designated by the letters RH (R0H to R7H) and RL (R0L to R7L). These registers are functionally equivalent, providing a maximum sixteen 8-bit registers.

Figure 2-4 illustrates the usage of the general registers. The usage of each register can be selected independently.

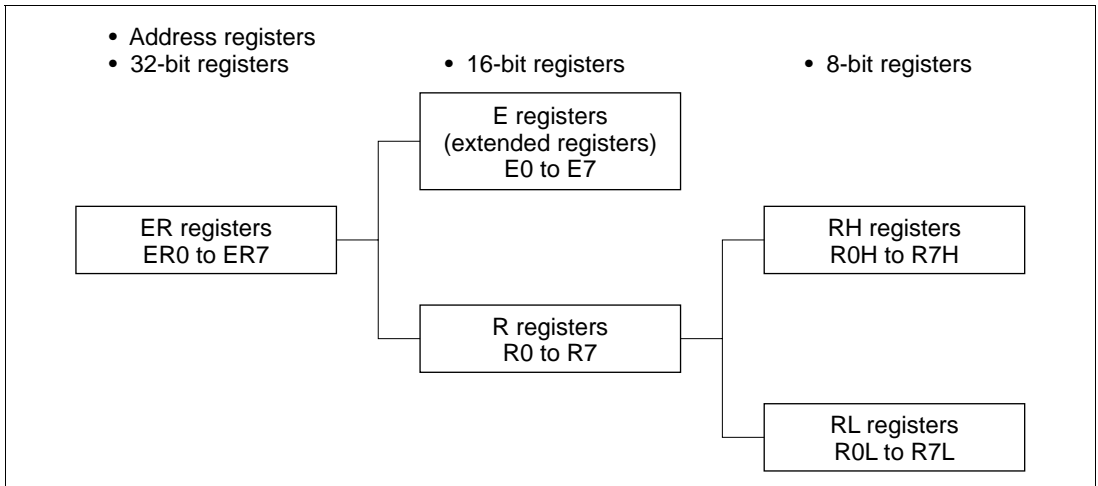

Figure 2-4 Usage of General Registers

General register ER7 has the function of stack pointer (SP) in addition to its general-register function, and is used implicitly in exception handling and subroutine calls. Figure 2-5 shows the stack.

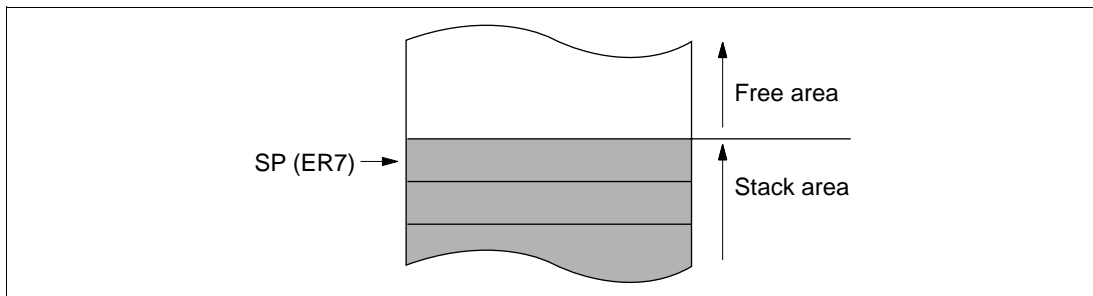

Figure 2-5 Stack

2.4.3 Control Registers

The control registers are the 24-bit program counter (PC) and the 8-bit condition code register (CCR).

Program Counter (PC): This 24-bit counter indicates the address of the next instruction the CPU will execute. The length of all CPU instructions is 2 bytes (one word) or a multiple of 2 bytes, so the least significant PC bit is ignored. When an instruction is fetched, the least significant PC bit is regarded as 0.

Condition Code Register (CCR): This 8-bit register contains internal CPU status information, including the interrupt mask bit (I) and half-carry (H), negative (N), zero (Z), overflow (V), and carry (C) flags.

Bit 7—Interrupt Mask Bit (I): Masks interrupts other than NMI when set to 1. NMI is accepted regardless of the I bit setting. The I bit is set to 1 at the start of an exception-handling sequence.

Bit 6—User Bit or Interrupt Mask Bit (UI): Can be written and read by software using the LDC, STC, ANDC, ORC, and XORC instructions. This bit can also be used as an interrupt mask bit. For details see section 5, Interrupt Controller.

Bit 5—Half-Carry Flag (H): When the ADD.B, ADDX.B, SUB.B, SUBX.B, CMP.B, or NEG.B instruction is executed, this flag is set to 1 if there is a carry or borrow at bit 3, and cleared to 0 otherwise. When the ADD.W, SUB.W, CMP.W, or NEG.W instruction is executed, the H flag is set to 1 if there is a carry or borrow at bit 11, and cleared to 0 otherwise. When the ADD.L, SUB.L, CMP.L, or NEG.L instruction is executed, the H flag is set to 1 if there is a carry or borrow at bit 27, and cleared to 0 otherwise.

Bit 4—User Bit (U): Can be written and read by software using the LDC, STC, ANDC, ORC, and XORC instructions.

Bit 3—Negative Flag (N): Stores the value of the most significant bit of data, regarded as the sign bit.

Bit 2—Zero Flag (Z): Set to 1 to indicate zero data, and cleared to 0 to indicate non-zero data.

Bit 1—Overflow Flag (V): Set to 1 when an arithmetic overflow occurs, and cleared to 0 at other times.

Bit 0—Carry Flag (C): Set to 1 when a carry is generated by execution of an operation, and cleared to 0 otherwise. Used by:

- Add instructions, to indicate a carry
- Subtract instructions, to indicate a borrow
- Shift and rotate instructions

The carry flag is also used as a bit accumulator by bit manipulation instructions.

Some instructions leave flag bits unchanged. Operations can be performed on CCR by the LDC, STC, ANDC, ORC, and XORC instructions. The N, Z, V, and C flags are used by conditional branch (Bcc) instructions.

For the action of each instruction on the flag bits, see appendix A.1, Instruction List. For the I and UI bits, see section 5, Interrupt Controller.

2.4.4 Initial CPU Register Values

In reset exception handling, PC is initialized to a value loaded from the vector table, and the I bit in CCR is set to 1. The other CCR bits and the general registers are not initialized. In particular, the initial value of the stack pointer (ER7) is also undefined. The stack pointer (ER7) must therefore be initialized by an MOV.L instruction executed immediately after a reset.

2.5 Data Formats

The H8/300H CPU can process 1-bit, 4-bit (BCD), 8-bit (byte), 16-bit (word), and 32-bit (longword) data. Bit-manipulation instructions operate on 1-bit data by accessing bit n ($n = 0, 1, 2, \dots, 7$) of byte operand data. The DAA and DAS decimal-adjust instructions treat byte data as two digits of 4-bit BCD data.

2.5.1 General Register Data Formats

Figures 2-6 and 2-7 show the data formats in general registers.

Data Type	General Register	Data Format
1-bit data	RnH	
1-bit data	RnL	
4-bit BCD data	RnH	
4-bit BCD data	RnL	
Byte data	RnH	
Byte data	RnL	
Legend		
RnH: General register RH		
RnL: General register RL		

Figure 2-6 General Register Data Formats

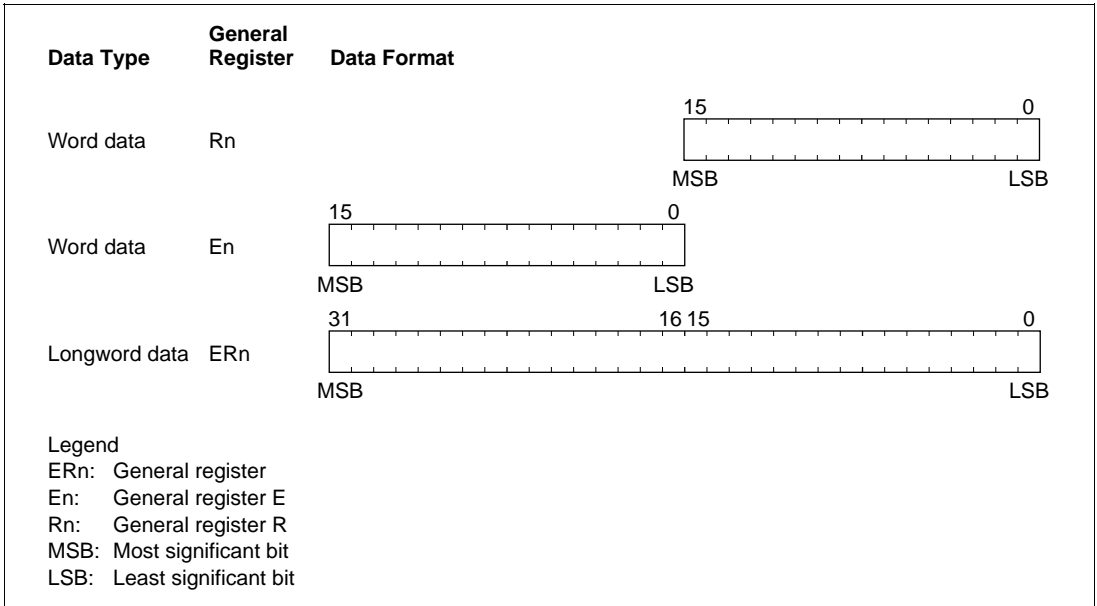

Figure 2-7 General Register Data Formats

2.5.2 Memory Data Formats

Figure 2-8 shows the data formats on memory. The H8/300H CPU can access word data and longword data on memory, but word or longword data must begin at an even address. If an attempt is made to access word or longword data at an odd address, no address error occurs but the least significant bit of the address is regarded as 0, so the access starts at the preceding address. This also applies to instruction fetches.

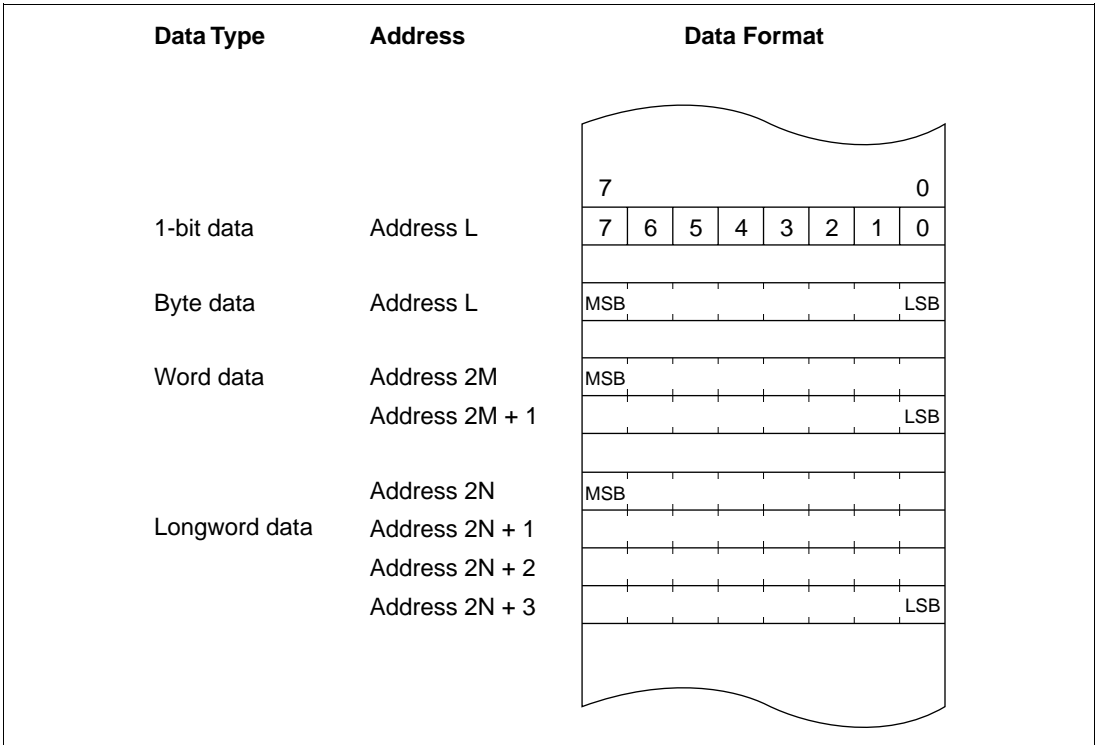

Figure 2-8 Memory Data Formats

When ER7 (SP) is used as an address register to access the stack, the operand size should be word size or longword size.

2.6 Instruction Set

2.6.1 Instruction Set Overview

The H8/300H CPU has 64 types of instructions, which are classified in table 2-1.

Table 2-1 Instruction Classification

Function	Instruction	Types
Data transfer	MOV, PUSH* ¹ , POP* ¹ , MOVTPE* ² , MOVFPE* ²	5
Arithmetic operations	ADD, SUB, ADDX, SUBX, INC, DEC, ADDS, SUBS, DAA, DAS, MULXU, MULXS, DIVXU, DIVXS, CMP, NEG, EXTS, EXTU	18
Logic operations	AND, OR, XOR, NOT	4
Shift operations	SHAL, SHAR, SHLL, SHLR, ROTL, ROTR, ROTXL, ROTXR	8
Bit manipulation	BSET, BCLR, BNOT, BTST, BAND, BAND, BOR, BIOR, BXOR, BIXOR, BLD, BILD, BST, BIST	14
Branch	Bcc* ³ , JMP, BSR, JSR, RTS	5
System control	TRAPA, RTE, SLEEP, LDC, STC, ANDC, ORC, XORC, NOP	9
Block data transfer	EPMOV	1
		Total 64 types

- Notes: 1. POP.W Rn is identical to MOV.W @SP+, Rn.
PUSH.W Rn is identical to MOV.W Rn, @-SP.
POP.L ERn is identical to MOV.L @SP+, Rn.
PUSH.L ERn is identical to MOV.L Rn, @-SP.
2. Not available in the H8/3006 and H8/3007.
3. Bcc is a generic branching instruction.

2.6.2 Instructions and Addressing Modes

Table 2-2 indicates the instructions available in the H8/300H CPU.

Table 2-2 Instructions and Addressing Modes

Function	Instruction	#xx	Rn	Addressing Modes										
				@ERn	@(d:16, ERn)	@(d:24, ERn)	@ERn+/@-ERn	@aa:8	@aa:16	@aa:24	@(d:8, PC)	@(d:16, PC)	@@aa:8	—
Data transfer	MOV	BWL	BWL	BWL	BWL	BWL	BWL	B	BWL	BWL	—	—	—	—
	POP, PUSH	—	—	—	—	—	—	—	—	—	—	—	—	WL
	MOVFP, MOVTP	—	—	—	—	—	—	—	—	—	—	—	—	—
Arithmetic operations	ADD, CMP	BWL	BWL	—	—	—	—	—	—	—	—	—	—	—
	SUB	WL	BWL	—	—	—	—	—	—	—	—	—	—	—
	ADDX, SUBX	B	B	—	—	—	—	—	—	—	—	—	—	—
	ADDS, SUBS	—	L	—	—	—	—	—	—	—	—	—	—	—
	INC, DEC	—	BWL	—	—	—	—	—	—	—	—	—	—	—
	DAA, DAS	—	B	—	—	—	—	—	—	—	—	—	—	—
	MULXU, MULXS, DIVXU, DIVXS	—	BW	—	—	—	—	—	—	—	—	—	—	—
	NEG	—	BWL	—	—	—	—	—	—	—	—	—	—	—
	EXTU, EXTS	—	WL	—	—	—	—	—	—	—	—	—	—	—
	Logic operations	AND, OR, XOR	—	BWL	—	—	—	—	—	—	—	—	—	—
NOT		—	BWL	—	—	—	—	—	—	—	—	—	—	—
Shift instructions	—	BWL	—	—	—	—	—	—	—	—	—	—	—	
Bit manipulation	—	B	B	—	—	—	—	B	—	—	—	—	—	
Branch	Bcc, BSR	—	—	—	—	—	—	—	—	—	—	—	—	—
	JMP, JSR	—	—	○	—	—	—	—	—	—	○	○	—	—
	RTS	—	—	—	—	—	—	—	—	○	—	—	○	—
System control	TRAPA	—	—	—	—	—	—	—	—	—	—	—	—	○
	RTE	—	—	—	—	—	—	—	—	—	—	—	—	○
	SLEEP	—	—	—	—	—	—	—	—	—	—	—	—	○
	LDC	B	B	W	W	W	W	—	W	W	—	—	—	○
	STC	—	B	W	W	W	W	—	W	W	—	—	—	—
	ANDC, ORC, XORC	B	—	—	—	—	—	—	—	—	—	—	—	—
	NOP	—	—	—	—	—	—	—	—	—	—	—	—	○
Block data transfer	—	—	—	—	—	—	—	—	—	—	—	—	—	BW

2.6.3 Tables of Instructions Classified by Function

Tables 2-3 to 2-10 summarize the instructions in each functional category. The operation notation used in these tables is defined next.

Operation Notation

Rd	General register (destination)*
Rs	General register (source)*
Rn	General register*
ERn	General register (32-bit register or address register)
(EAd)	Destination operand
(EAs)	Source operand
CCR	Condition code register
N	N (negative) flag of CCR
Z	Z (zero) flag of CCR
V	V (overflow) flag of CCR
C	C (carry) flag of CCR
PC	Program counter
SP	Stack pointer
#IMM	Immediate data
disp	Displacement
+	Addition
-	Subtraction
×	Multiplication
÷	Division
^	AND logical
∨	OR logical
⊕	Exclusive OR logical
→	Move
¬	NOT (logical complement)
:3/:8/:16/:24	3-, 8-, 16-, or 24-bit length

Note: * General registers include 8-bit registers (R0H to R7H, R0L to R7L), 16-bit registers (R0 to R7, E0 to E7), and 32-bit data or address registers (ER0 to ER7).

Table 2-3 Data Transfer Instructions

Instruction	Size*	Function
MOV	B/W/L	(EAs) → Rd, Rs → (EAd) Moves data between two general registers or between a general register and memory, or moves immediate data to a general register.
MOVFPE	B	(EAs) → Rd Cannot be used in this LSI.
MOVTPE	B	Rs → (EAs) Cannot be used in this LSI.
POP	W/L	@SP+ → Rn Pops a general register from the stack. POP.W Rn is identical to MOV.W @SP+, Rn. Similarly, POP.L ERn is identical to MOV.L @SP+, ERn.
PUSH	W/L	Rn → @-SP Pushes a general register onto the stack. PUSH.W Rn is identical to MOV.W Rn, @-SP. Similarly, PUSH.L ERn is identical to MOV.L ERn, @-SP.

Note: * Size refers to the operand size.

B: Byte

W: Word

L: Longword

Table 2-4 Arithmetic Operation Instructions

Instruction	Size*	Function
ADD,SUB	B/W/L	$Rd \pm Rs \rightarrow Rd, Rd \pm \#IMM \rightarrow Rd$ Performs addition or subtraction on data in two general registers, or on immediate data and data in a general register. (Immediate byte data cannot be subtracted from data in a general register. Use the SUBX or ADD instruction.)
ADDX, SUBX	B	$Rd \pm Rs \pm C \rightarrow Rd, Rd \pm \#IMM \pm C \rightarrow Rd$ Performs addition or subtraction with carry or borrow on data in two general registers, or on immediate data and data in a general register.
INC, DEC	B/W/L	$Rd \pm 1 \rightarrow Rd, Rd \pm 2 \rightarrow Rd$ Increments or decrements a general register by 1 or 2. (Byte operands can be incremented or decremented by 1 only.)
ADDS, SUBS	L	$Rd \pm 1 \rightarrow Rd, Rd \pm 2 \rightarrow Rd, Rd \pm 4 \rightarrow Rd$ Adds or subtracts the value 1, 2, or 4 to or from data in a 32-bit register.
DAA, DAS	B	$Rd \text{ decimal adjust} \rightarrow Rd$ Decimal-adjusts an addition or subtraction result in a general register by referring to CCR to produce 4-bit BCD data.
MULXU	B/W	$Rd \times Rs \rightarrow Rd$ Performs unsigned multiplication on data in two general registers: either 8 bits \times 8 bits \rightarrow 16 bits or 16 bits \times 16 bits \rightarrow 32 bits.
MULXS	B/W	$Rd \times Rs \rightarrow Rd$ Performs signed multiplication on data in two general registers: either 8 bits \times 8 bits \rightarrow 16 bits or 16 bits \times 16 bits \rightarrow 32 bits.

Instruction	Size*	Function
DIVXU	B/W	$Rd \div Rs \rightarrow Rd$ Performs unsigned division on data in two general registers: either 16 bits \div 8 bits \rightarrow 8-bit quotient and 8-bit remainder or 32 bits \div 16 bits \rightarrow 16-bit quotient and 16-bit remainder
DIVXS	B/W	$Rd \div Rs \rightarrow Rd$ Performs signed division on data in two general registers: either 16 bits \div 8 bits \rightarrow 8-bit quotient and 8-bit remainder, or 32 bits \div 16 bits \rightarrow 16-bit quotient and 16-bit remainder
CMP	B/W/L	$Rd - Rs, Rd - \#IMM$ Compares data in a general register with data in another general register or with immediate data, and sets CCR according to the result.
NEG	B/W/L	$0 - Rd \rightarrow Rd$ Takes the two's complement (arithmetic complement) of data in a general register.
EXTS	W/L	Rd (sign extension) $\rightarrow Rd$ Extends byte data in the lower 8 bits of a 16-bit register to word data, or extends word data in the lower 16 bits of a 32-bit register to longword data, by extending the sign bit.
EXTU	W/L	Rd (zero extension) $\rightarrow Rd$ Extends byte data in the lower 8 bits of a 16-bit register to word data, or extends word data in the lower 16 bits of a 32-bit register to longword data, by padding with zeros.

Note: * Size refers to the operand size.

B: Byte

W: Word

L: Longword

Table 2-5 Logic Operation Instructions

Instruction	Size*	Function
AND	B/W/L	$Rd \wedge Rs \rightarrow Rd$, $Rd \wedge \#IMM \rightarrow Rd$ Performs a logical AND operation on a general register and another general register or immediate data.
OR	B/W/L	$Rd \vee Rs \rightarrow Rd$, $Rd \vee \#IMM \rightarrow Rd$ Performs a logical OR operation on a general register and another general register or immediate data.
XOR	B/W/L	$Rd \oplus Rs \rightarrow Rd$, $Rd \oplus \#IMM \rightarrow Rd$ Performs a logical exclusive OR operation on a general register and another general register or immediate data.
NOT	B/W/L	$\neg Rd \rightarrow Rd$ Takes the one's complement (logical complement) of general register contents.

Note: * Size refers to the operand size.

B: Byte

W: Word

L: Longword

Table 2-6 Shift Instructions

Instruction	Size*	Function
SHAL, SHAR	B/W/L	$Rd \text{ (shift)} \rightarrow Rd$ Performs an arithmetic shift on general register contents.
SHLL, SHLR	B/W/L	$Rd \text{ (shift)} \rightarrow Rd$ Performs a logical shift on general register contents.
ROTL, ROTR	B/W/L	$Rd \text{ (rotate)} \rightarrow Rd$ Rotates general register contents.
ROTXL, ROTXR	B/W/L	$Rd \text{ (rotate)} \rightarrow Rd$ Rotates general register contents, including the carry bit.

Note: * Size refers to the operand size.

B: Byte

W: Word

L: Longword

Table 2-7 Bit Manipulation Instructions

Instruction	Size*	Function
BSET	B	$1 \rightarrow (\text{<bit-No.> of <EAd>})$ Sets a specified bit in a general register or memory operand to 1. The bit number is specified by 3-bit immediate data or the lower 3 bits of a general register.
BCLR	B	$0 \rightarrow (\text{<bit-No.> of <EAd>})$ Clears a specified bit in a general register or memory operand to 0. The bit number is specified by 3-bit immediate data or the lower 3 bits of a general register.
BNOT	B	$\neg (\text{<bit-No.> of <EAd>}) \rightarrow (\text{<bit-No.> of <EAd>})$ Inverts a specified bit in a general register or memory operand. The bit number is specified by 3-bit immediate data or the lower 3 bits of a general register.
BTST	B	$\neg (\text{<bit-No.> of <EAd>}) \rightarrow Z$ Tests a specified bit in a general register or memory operand and sets or clears the Z flag accordingly. The bit number is specified by 3-bit immediate data or the lower 3 bits of a general register.
BAND	B	$C \wedge (\text{<bit-No.> of <EAd>}) \rightarrow C$ ANDs the carry flag with a specified bit in a general register or memory operand and stores the result in the carry flag. The bit number is specified by 3-bit immediate data.
BIAND	B	$C \wedge [\neg (\text{<bit-No.> of <EAd>})] \rightarrow C$ ANDs the carry flag with the inverse of a specified bit in a general register or memory operand and stores the result in the carry flag. The bit number is specified by 3-bit immediate data.

Instruction	Size*	Function
BOR	B	$C \vee (\langle \text{bit-No.} \rangle \text{ of } \langle \text{EAd} \rangle) \rightarrow C$ ORs the carry flag with a specified bit in a general register or memory operand and stores the result in the carry flag. The bit number is specified by 3-bit immediate data.
BIOR	B	$C \vee [\neg (\langle \text{bit-No.} \rangle \text{ of } \langle \text{EAd} \rangle)] \rightarrow C$ ORs the carry flag with the inverse of a specified bit in a general register or memory operand and stores the result in the carry flag. The bit number is specified by 3-bit immediate data.
BXOR	B	$C \oplus (\langle \text{bit-No.} \rangle \text{ of } \langle \text{EAd} \rangle) \rightarrow C$ Exclusive-ORs the carry flag with a specified bit in a general register or memory operand and stores the result in the carry flag. The bit number is specified by 3-bit immediate data.
BIXOR	B	$C \oplus [\neg (\langle \text{bit-No.} \rangle \text{ of } \langle \text{EAd} \rangle)] \rightarrow C$ Exclusive-ORs the carry flag with the inverse of a specified bit in a general register or memory operand and stores the result in the carry flag. The bit number is specified by 3-bit immediate data.
BLD	B	$(\langle \text{bit-No.} \rangle \text{ of } \langle \text{EAd} \rangle) \rightarrow C$ Transfers a specified bit in a general register or memory operand to the carry flag. The bit number is specified by 3-bit immediate data.
BILD	B	$\neg (\langle \text{bit-No.} \rangle \text{ of } \langle \text{EAd} \rangle) \rightarrow C$ Transfers the inverse of a specified bit in a general register or memory operand to the carry flag. The bit number is specified by 3-bit immediate data.
BST	B	$C \rightarrow (\langle \text{bit-No.} \rangle \text{ of } \langle \text{EAd} \rangle)$ Transfers the carry flag value to a specified bit in a general register or memory operand. The bit number is specified by 3-bit immediate data.
BIST	B	$C \rightarrow \neg (\langle \text{bit-No.} \rangle \text{ of } \langle \text{EAd} \rangle)$ Transfers the inverse of the carry flag value to a specified bit in a general register or memory operand. The bit number is specified by 3-bit immediate data.

Note: * Size refers to the operand size.

B: Byte

Table 2-8 Branching Instructions

Instruction	Size	Function																																																			
Bcc	—	Branches to a specified address if address specified condition is met. The branching conditions are listed below.																																																			
		<table border="1"> <thead> <tr> <th>Mnemonic</th> <th>Description</th> <th>Condition</th> </tr> </thead> <tbody> <tr> <td>BRA (BT)</td> <td>Always (true)</td> <td>Always</td> </tr> <tr> <td>BRN (BF)</td> <td>Never (false)</td> <td>Never</td> </tr> <tr> <td>BHI</td> <td>High</td> <td>$C \vee Z = 0$</td> </tr> <tr> <td>BLS</td> <td>Low or same</td> <td>$C \vee Z = 1$</td> </tr> <tr> <td>Bcc (BHS)</td> <td>Carry clear (high or same)</td> <td>$C = 0$</td> </tr> <tr> <td>BCS (BLO)</td> <td>Carry set (low)</td> <td>$C = 1$</td> </tr> <tr> <td>BNE</td> <td>Not equal</td> <td>$Z = 0$</td> </tr> <tr> <td>BEQ</td> <td>Equal</td> <td>$Z = 1$</td> </tr> <tr> <td>BVC</td> <td>Overflow clear</td> <td>$V = 0$</td> </tr> <tr> <td>BVS</td> <td>Overflow set</td> <td>$V = 1$</td> </tr> <tr> <td>BPL</td> <td>Plus</td> <td>$N = 0$</td> </tr> <tr> <td>BMI</td> <td>Minus</td> <td>$N = 1$</td> </tr> <tr> <td>BGE</td> <td>Greater or equal</td> <td>$N \oplus V = 0$</td> </tr> <tr> <td>BLT</td> <td>Less than</td> <td>$N \oplus V = 1$</td> </tr> <tr> <td>BGT</td> <td>Greater than</td> <td>$Z \vee (N \oplus V) = 0$</td> </tr> <tr> <td>BLE</td> <td>Less or equal</td> <td>$Z \vee (N \oplus V) = 1$</td> </tr> </tbody> </table>	Mnemonic	Description	Condition	BRA (BT)	Always (true)	Always	BRN (BF)	Never (false)	Never	BHI	High	$C \vee Z = 0$	BLS	Low or same	$C \vee Z = 1$	Bcc (BHS)	Carry clear (high or same)	$C = 0$	BCS (BLO)	Carry set (low)	$C = 1$	BNE	Not equal	$Z = 0$	BEQ	Equal	$Z = 1$	BVC	Overflow clear	$V = 0$	BVS	Overflow set	$V = 1$	BPL	Plus	$N = 0$	BMI	Minus	$N = 1$	BGE	Greater or equal	$N \oplus V = 0$	BLT	Less than	$N \oplus V = 1$	BGT	Greater than	$Z \vee (N \oplus V) = 0$	BLE	Less or equal	$Z \vee (N \oplus V) = 1$
Mnemonic	Description	Condition																																																			
BRA (BT)	Always (true)	Always																																																			
BRN (BF)	Never (false)	Never																																																			
BHI	High	$C \vee Z = 0$																																																			
BLS	Low or same	$C \vee Z = 1$																																																			
Bcc (BHS)	Carry clear (high or same)	$C = 0$																																																			
BCS (BLO)	Carry set (low)	$C = 1$																																																			
BNE	Not equal	$Z = 0$																																																			
BEQ	Equal	$Z = 1$																																																			
BVC	Overflow clear	$V = 0$																																																			
BVS	Overflow set	$V = 1$																																																			
BPL	Plus	$N = 0$																																																			
BMI	Minus	$N = 1$																																																			
BGE	Greater or equal	$N \oplus V = 0$																																																			
BLT	Less than	$N \oplus V = 1$																																																			
BGT	Greater than	$Z \vee (N \oplus V) = 0$																																																			
BLE	Less or equal	$Z \vee (N \oplus V) = 1$																																																			
JMP	—	Branches unconditionally to a specified address																																																			
BSR	—	Branches to a subroutine at a specified address																																																			
JSR	—	Branches to a subroutine at a specified address																																																			
RTS	—	Returns from a subroutine																																																			

Table 2-9 System Control Instructions

Instruction	Size*	Function
TRAPA	—	Starts trap-instruction exception handling
RTE	—	Returns from an exception-handling routine
SLEEP	—	Causes a transition to the power-down state
LDC	B/W	(EAs) → CCR Moves the source operand contents to the condition code register. The condition code register size is one byte, but in transfer from memory, data is read by word access.
STC	B/W	CCR → (EAd) Transfers the CCR contents to a destination location. The condition code register size is one byte, but in transfer to memory, data is written by word access.
ANDC	B	CCR ∧ #IMM → CCR Logically ANDs the condition code register with immediate data.
ORC	B	CCR ∨ #IMM → CCR Logically ORs the condition code register with immediate data.
XORC	B	CCR ⊕ #IMM → CCR Logically exclusive-ORs the condition code register with immediate data.
NOP	—	PC + 2 → PC Only increments the program counter.

Note: * Size refers to the operand size.

B: Byte

W: Word

Table 2-10 Block Transfer Instruction

Instruction	Size	Function
EEPMOV.B	—	if R4L ≠ 0 then repeat @ER5+ → @ER6+, R4L - 1 → R4L until R4L = 0 else next;
EEPMOV.W	—	if R4 ≠ 0 then repeat @ER5+ → @ER6+, R4 - 1 → R4 until R4 = 0 else next; Block transfer instruction. This instruction transfers the number of data bytes specified by R4L or R4, starting from the address indicated by ER5, to the location starting at the address indicated by ER6. At the end of the transfer, the next instruction is executed.

2.6.4 Basic Instruction Formats

The H8/300H instructions consist of 2-byte (1-word) units. An instruction consists of an operation field (OP field), a register field (r field), an effective address extension (EA field), and a condition field (cc).

Operation Field: Indicates the function of the instruction, the addressing mode, and the operation to be carried out on the operand. The operation field always includes the first 4 bits of the instruction. Some instructions have two operation fields.

Register Field: Specifies a general register. Address registers are specified by 3 bits, data registers by 3 bits or 4 bits. Some instructions have two register fields. Some have no register field.

Effective Address Extension: Eight, 16, or 32 bits specifying immediate data, an absolute address, or a displacement. A 24-bit address or displacement is treated as 32-bit data in which the first 8 bits are 0 (H'00).

Condition Field: Specifies the branching condition of Bcc instructions.

Figure 2-9 shows examples of instruction formats.

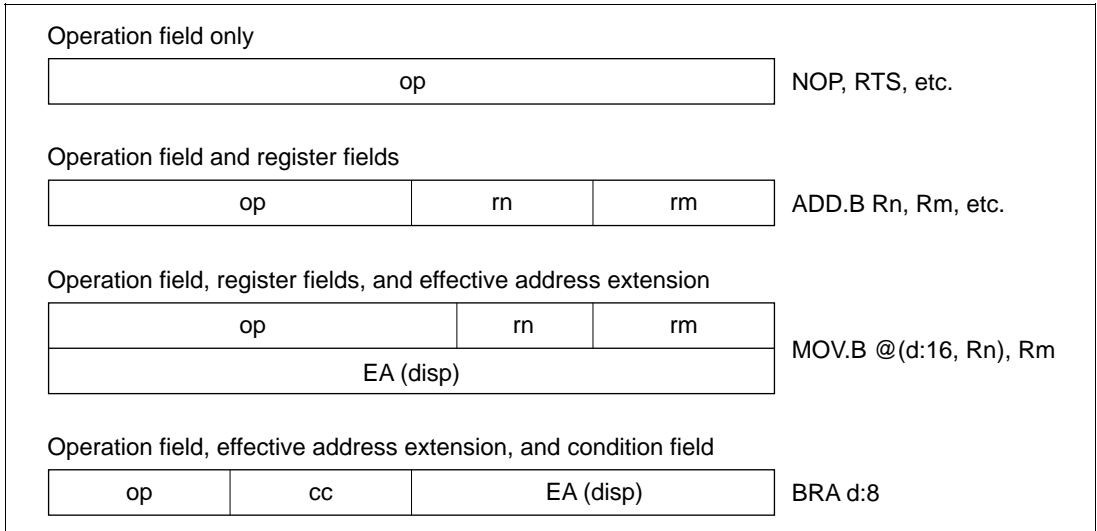

Figure 2-9 Instruction Formats

2.6.5 Notes on Use of Bit Manipulation Instructions

The BSET, BCLR, BNOT, BST, and BIST instructions read a byte of data, modify a bit in the byte, then write the byte back. Care is required when these instructions are used to access registers with write-only bits, or to access ports.

Step	Description	
1	Read	Read one data byte at the specified address
2	Modify	Modify one bit in the data byte
3	Write	Write the modified data byte back to the specified address

Example 1: BCLR is executed to clear bit 0 in the port 4 data direction register (P4DDR) under the following conditions.

- P4₇, P4₆: Input pins
- P4₅ – P4₀: Output pins

The intended purpose of this BCLR instruction is to switch P4₀ from output to input.

Before Execution of BCLR Instruction

	P4 ₇	P4 ₆	P4 ₅	P4 ₄	P4 ₃	P4 ₂	P4 ₁	P4 ₀
Input/output	Input	Input	Output	Output	Output	Output	Output	Output
DDR	0	0	1	1	1	1	1	1

Execution of BCLR Instruction

BCLR #0, @P4DDR ;Clear bit 0 in data direction register

After Execution of BCLR Instruction

	P4 ₇	P4 ₆	P4 ₅	P4 ₄	P4 ₃	P4 ₂	P4 ₁	P4 ₀
Input/output	Output	Output	Output	Output	Output	Output	Output	Input
DDR	1	1	1	1	1	1	1	0

Explanation: To execute the BCLR instruction, the CPU begins by reading P4DDR. Since P4DDR is a write-only register, it is read as H'FF, even though its true value is H'3F.

Next the CPU clears bit 0 of the read data, changing the value to H'FE.

Finally, the CPU writes this value (H'FE) back to P4DDR to complete the BCLR instruction.

As a result, P4₀DDR is cleared to 0, making P4₀ an input pin. In addition, P4₇DDR and P4₆DDR are set to 1, making P4₇ and P4₆ output pins.

The BCLR instruction can be used to clear flags in the on-chip registers to 0. In the case of the IRQ status register (ISR), for example, a flag must be read as a condition for clearing it, but when using the BCLR instruction, if it is known that a flag has been set to 1 in an interrupt-handling routine, for instance, it is not necessary to read the flag ahead of time.

2.7 Addressing Modes and Effective Address Calculation

2.7.1 Addressing Modes

The H8/300H CPU supports the eight addressing modes listed in table 2-11. Each instruction uses a subset of these addressing modes. Arithmetic and logic instructions can use the register direct and immediate modes. Data transfer instructions can use all addressing modes except program-counter relative and memory indirect. Bit manipulation instructions use register direct, register indirect, or absolute (@aa:8) addressing mode to specify an operand, and register direct (BSET, BCLR, BNOT, and BTST instructions) or immediate (3-bit) addressing mode to specify a bit number in the operand.

Table 2-11 Addressing Modes

No.	Addressing Mode	Symbol
1	Register direct	Rn
2	Register indirect	@ERn
3	Register indirect with displacement	@(d:16, ERn)/@(d:24, ERn)
4	Register indirect with post-increment Register indirect with pre-decrement	@ERn+ @-ERn
5	Absolute address	@aa:8/@aa:16/@aa:24
6	Immediate	#xx:8/#xx:16/#xx:32
7	Program-counter relative	@(d:8, PC)/@(d:16, PC)
8	Memory indirect	@@aa:8

1 Register Direct—Rn: The register field of the instruction code specifies an 8-, 16-, or 32-bit register containing the operand. R0H to R7H and R0L to R7L can be specified as 8-bit registers. R0 to R7 and E0 to E7 can be specified as 16-bit registers. ER0 to ER7 can be specified as 32-bit registers.

2 Register Indirect—@ERn: The register field of the instruction code specifies an address register (ERn), the lower 24 bits of which contain the address of the operand.

3 Register Indirect with Displacement—@(d:16, ERn) or @(d:24, ERn): A 16-bit or 24-bit displacement contained in the instruction code is added to the contents of an address register (ERn) specified by the register field of the instruction, and the lower 24 bits of the sum specify the address of a memory operand. A 16-bit displacement is sign-extended when added.

4 Register Indirect with Post-Increment or Pre-Decrement—@ERn+ or @-ERn:

- Register indirect with post-increment—@ERn+

The register field of the instruction code specifies an address register (ERn) the lower 24 bits of which contain the address of a memory operand. After the operand is accessed, 1, 2, or 4 is added to the address register contents (32 bits) and the sum is stored in the address register. The value added is 1 for byte access, 2 for word access, or 4 for longword access. For word or longword access, the register value should be even.

- Register indirect with pre-decrement—@-ERn

The value 1, 2, or 4 is subtracted from an address register (ERn) specified by the register field in the instruction code, and the lower 24 bits of the result become the address of a memory operand. The result is also stored in the address register. The value subtracted is 1 for byte access, 2 for word access, or 4 for longword access. For word or longword access, the resulting register value should be even.

5 Absolute Address—@aa:8, @aa:16, or @aa:24: The instruction code contains the absolute address of a memory operand. The absolute address may be 8 bits long (@aa:8), 16 bits long (@aa:16), or 24 bits long (@aa:24). For an 8-bit absolute address, the upper 16 bits are all assumed to be 1 (H'FFFF). For a 16-bit absolute address the upper 8 bits are a sign extension. A 24-bit absolute address can access the entire address space. Table 2-12 indicates the accessible address ranges.

Table 2-12 Absolute Address Access Ranges

Absolute Address	1-Mbyte Modes	16-Mbyte Modes
8 bits (@aa:8)	H'FFF00 to H'FFFFFF (1048320 to 1048575)	H'FFFF00 to H'FFFFFFF (16776960 to 16777215)
16 bits (@aa:16)	H'00000 to H'07FFF, H'F8000 to H'FFFFFF (0 to 32767, 1015808 to 1048575)	H'000000 to H'007FFF, H'FF8000 to H'FFFFFFF (0 to 32767, 16744448 to 16777215)
24 bits (@aa:24)	H'00000 to H'FFFFFF (0 to 1048575)	H'000000 to H'FFFFFFF (0 to 16777215)

6 Immediate—#xx:8, #xx:16, or #xx:32: The instruction code contains 8-bit (#xx:8), 16-bit (#xx:16), or 32-bit (#xx:32) immediate data as an operand.

The instruction codes of the ADDS, SUBS, INC, and DEC instructions contain immediate data implicitly. The instruction codes of some bit manipulation instructions contain 3-bit immediate data specifying a bit number. The TRAPA instruction code contains 2-bit immediate data specifying a vector address.

7 Program-Counter Relative—@(d**:8, PC) or @(**d**:16, PC):** This mode is used in the Bcc and BSR instructions. An 8-bit or 16-bit displacement contained in the instruction code is sign-extended to 24 bits and added to the 24-bit PC contents to generate a 24-bit branch address. The PC value to which the displacement is added is the address of the first byte of the next instruction, so the possible branching range is -126 to $+128$ bytes (-63 to $+64$ words) or -32766 to $+32768$ bytes (-16383 to $+16384$ words) from the branch instruction. The resulting value should be an even number.

8 Memory Indirect—@@aa**:8:** This mode can be used by the JMP and JSR instructions. The instruction code contains an 8-bit absolute address specifying a memory operand. This memory operand contains a branch address. The memory operand is accessed by longword access. The first byte of the memory operand is ignored, generating a 24-bit branch address. See figure 2-10. The upper bits of the 8-bit absolute address are assumed to be 0 (H'0000), so the address range is 0 to 255 (H'000000 to H'0000FF). Note that the first part of this range is also the exception vector area. For further details see section 5, Interrupt Controller.

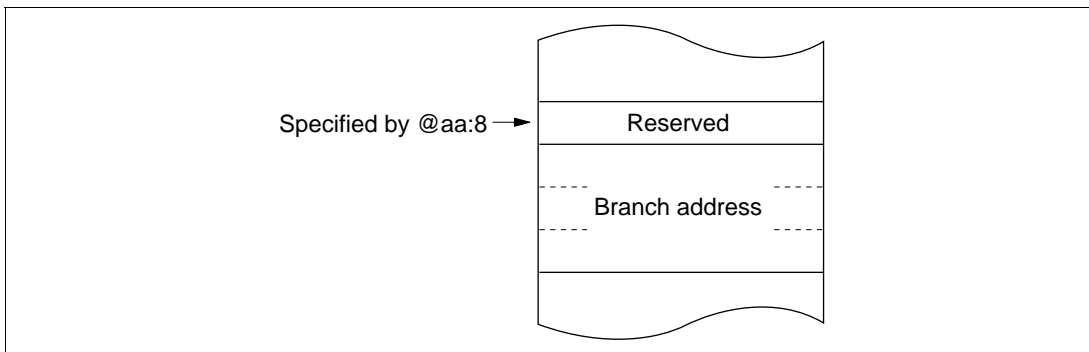



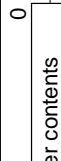

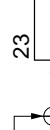
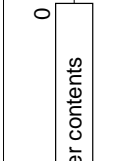
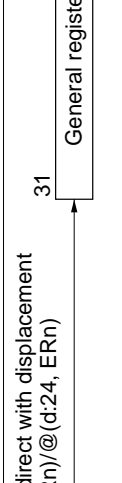
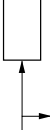

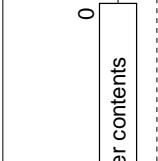
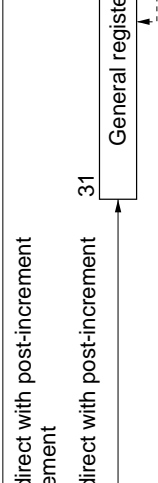
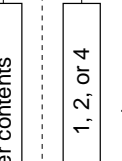

Figure 2-10 Memory-Indirect Branch Address Specification

When a word-size or longword-size memory operand is specified, or when a branch address is specified, if the specified memory address is odd, the least significant bit is regarded as 0. The accessed data or instruction code therefore begins at the preceding address. See section 2.5.2, Memory Data Formats.

2.7.2 Effective Address Calculation

Table 2-13 explains how an effective address is calculated in each addressing mode. In the 1-Mbyte operating modes the upper 4 bits of the calculated address are ignored in order to generate a 20-bit effective address.

Table 2-13 Effective Address Calculation

No.	Addressing Mode and Instruction Format	Effective Address Calculation	Effective Address
1	Register direct (Rn) 		Operand is general register contents
2	Register indirect (@ERn) 		
3	Register indirect with displacement @(d:16, ERn)/@(d:24, ERn) 		
4	Register indirect with post-increment or pre-decrement Register indirect with post-increment @ERn+  Register indirect with pre-decrement @-ERn 		
			

1 for a byte operand,
2 for a word operand,
4 for a longword operand

Addressing Mode and Instruction Format

Effective Address Calculation

Effective Address

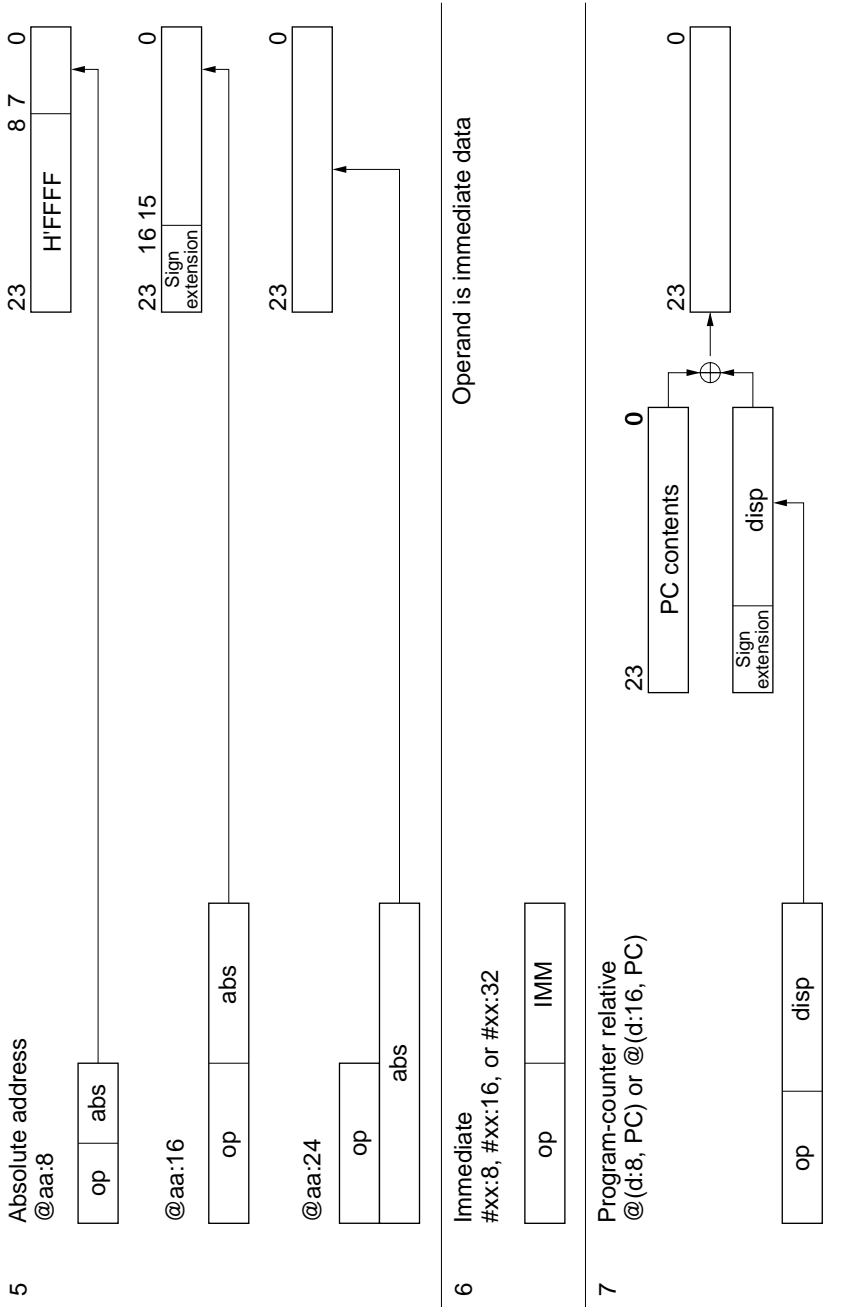

Addressing Mode and Instruction Format

Effective Address Calculation

Effective Address

No.

8 Memory indirect @@aa:8

Normal mode

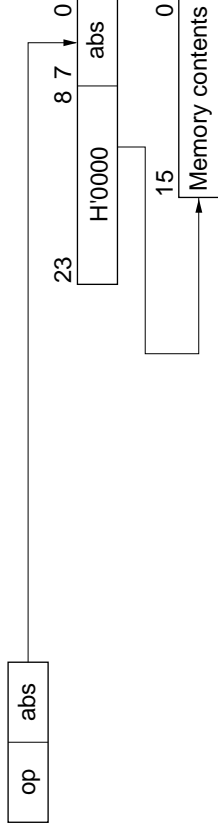

Advanced mode

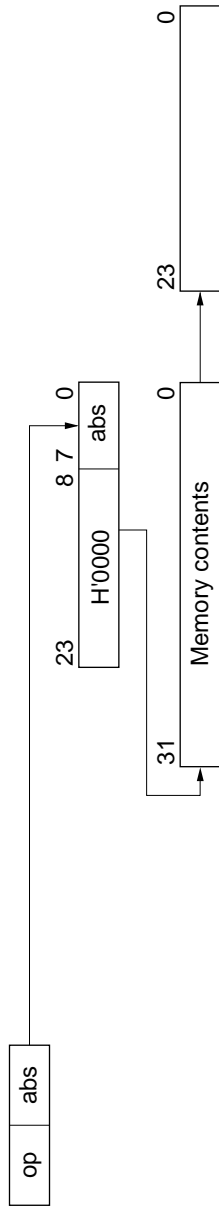

Legend

- r, rm, rn: Register field
- op: Operation field
- disp: Displacement
- IMM: Immediate data
- abs: Absolute address

2.8 Processing States

2.8.1 Overview

The H8/300H CPU has five processing states: the program execution state, exception-handling state, power-down state, reset state, and bus-released state. The power-down state includes sleep mode, software standby mode, and hardware standby mode. Figure 2-11 classifies the processing states. Figure 2-13 indicates the state transitions.

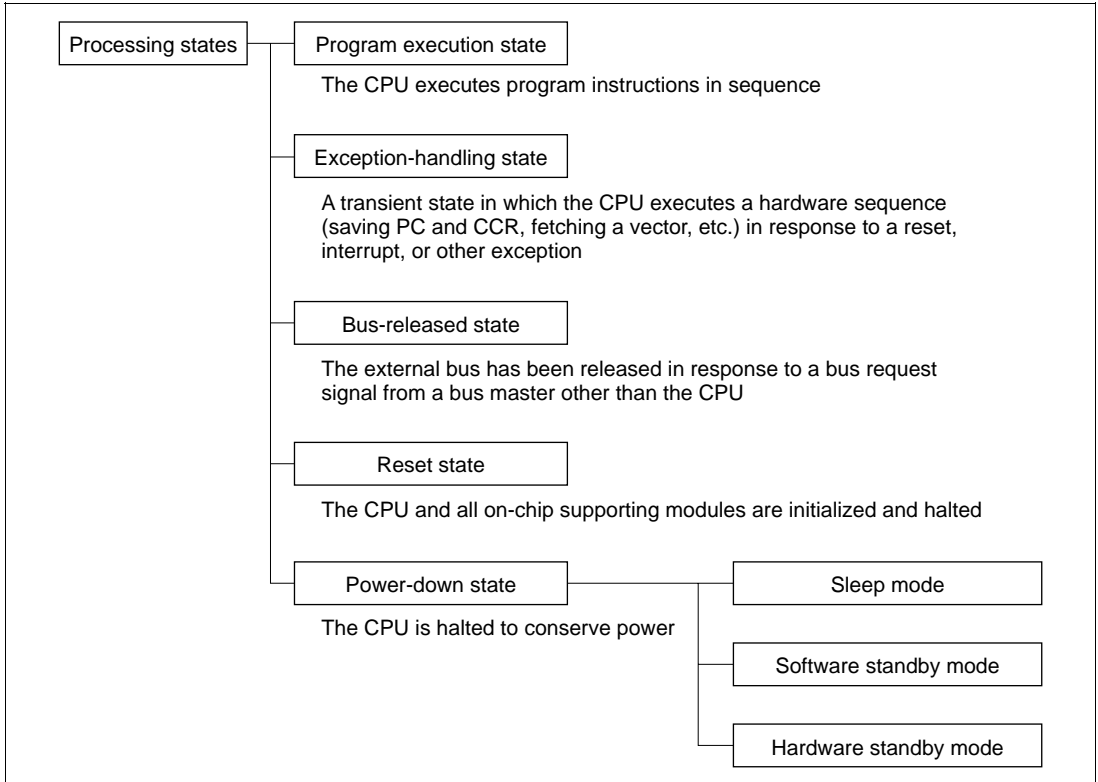

Figure 2-11 Processing States

2.8.2 Program Execution State

In this state the CPU executes program instructions in normal sequence.

2.8.3 Exception-Handling State

The exception-handling state is a transient state that occurs when the CPU alters the normal program flow due to a reset, interrupt, or trap instruction. The CPU fetches a starting address from the exception vector table and branches to that address. In interrupt and trap exception handling the CPU references the stack pointer (ER7) and saves the program counter and condition code register.

Types of Exception Handling and Their Priority: Exception handling is performed for resets, interrupts, and trap instructions. Table 2-14 indicates the types of exception handling and their priority. Trap instruction exceptions are accepted at all times in the program execution state.

Table 2-14 Exception Handling Types and Priority

Priority	Type of Exception	Detection Timing	Start of Exception Handling
High	Reset	Synchronized with clock	Exception handling starts immediately when $\overline{\text{RES}}$ changes from low to high
	Interrupt	End of instruction execution or end of exception handling*	When an interrupt is requested, exception handling starts at the end of the current instruction or current exception-handling sequence
Low	Trap instruction	When TRAPA instruction is executed	Exception handling starts when a trap (TRAPA) instruction is executed

Note: * Interrupts are not detected at the end of the ANDC, ORC, XORC, and LDC instructions, or immediately after reset exception handling.

Figure 2-12 classifies the exception sources. For further details about exception sources, vector numbers, and vector addresses, see section 4, Exception Handling, and section 5, Interrupt Controller.

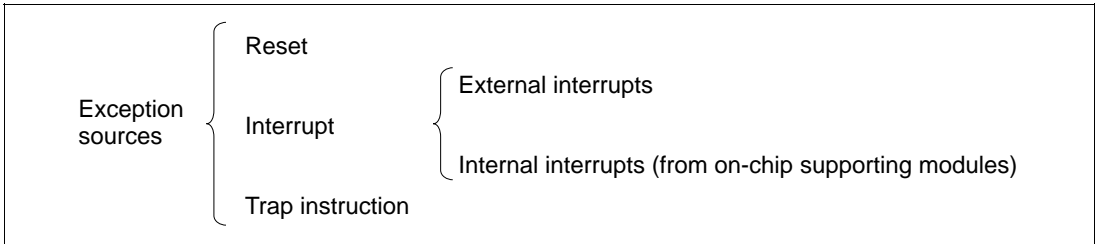

Figure 2-12 Classification of Exception Sources

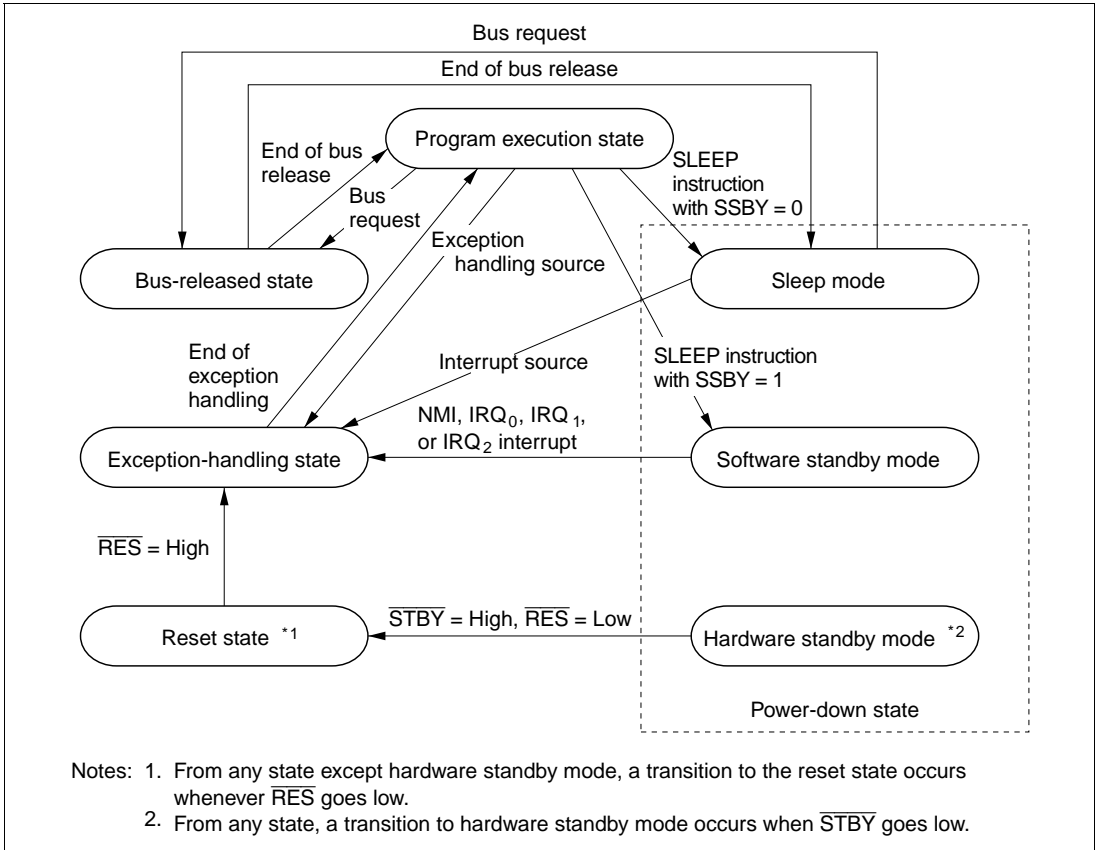

Figure 2-13 State Transitions

2.8.4 Exception-Handling Sequences

Reset Exception Handling: Reset exception handling has the highest priority. The reset state is entered when the $\overline{\text{RES}}$ signal goes low. Reset exception handling starts after that, when $\overline{\text{RES}}$ changes from low to high. When reset exception handling starts the CPU fetches a start address from the exception vector table and starts program execution from that address. All interrupts, including NMI, are disabled during the reset exception-handling sequence and immediately after it ends.

Interrupt Exception Handling and Trap Instruction Exception Handling: When these exception-handling sequences begin, the CPU references the stack pointer (ER7) and pushes the program counter and condition code register on the stack. Next, if the UE bit in the system control register (SYSCR) is set to 1, the CPU sets the I bit in the condition code register to 1. If the UE bit is cleared to 0, the CPU sets both the I bit and the UI bit in the condition code register to 1. Then the CPU fetches a start address from the exception vector table and execution branches to that address.

Figure 2-14 shows the stack after the exception-handling sequence.

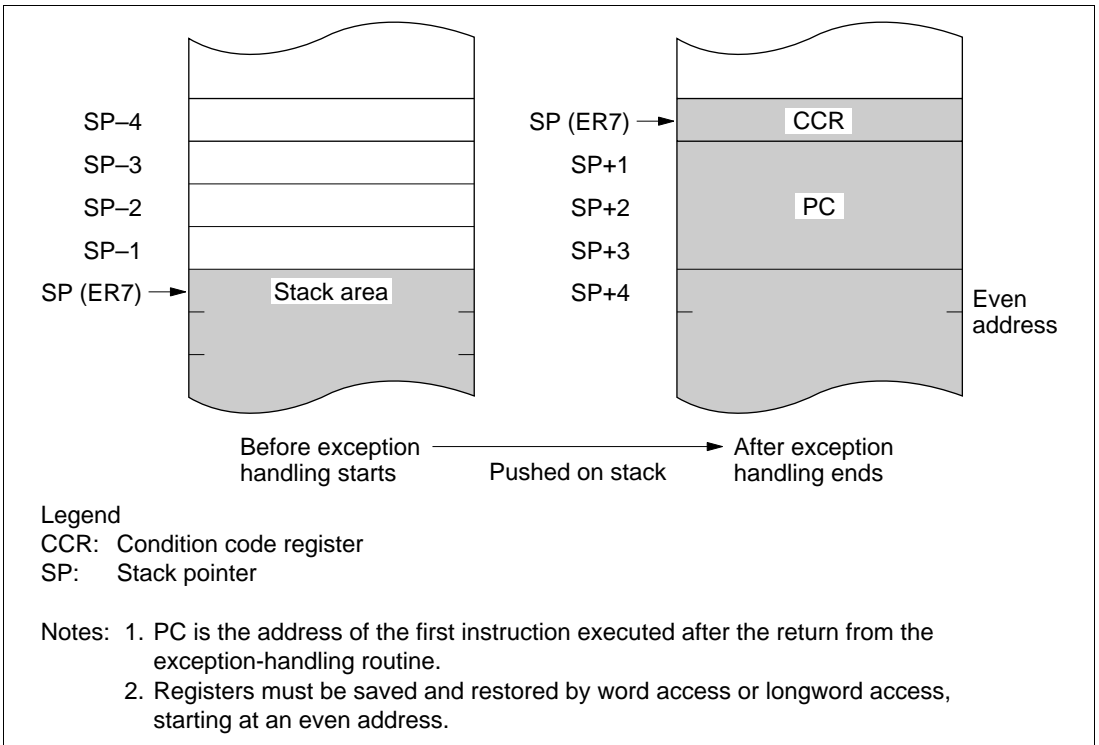

Figure 2-14 Stack Structure after Exception Handling

2.8.5 Bus-Released State

In this state the bus is released to a bus master other than the CPU, in response to a bus request. The bus masters other than the CPU are the DMA controller, the DRAM interface, and an external bus master. While the bus is released, the CPU halts except for internal operations. Interrupt requests are not accepted. For details see section 6.10, Bus Arbiter.

2.8.6 Reset State

When the $\overline{\text{RES}}$ input goes low all current processing stops and the CPU enters the reset state. The I bit in the condition code register is set to 1 by a reset. All interrupts are masked in the reset state. Reset exception handling starts when the $\overline{\text{RES}}$ signal changes from low to high.

The reset state can also be entered by a watchdog timer overflow. For details see section 12, Watchdog Timer.

2.8.7 Power-Down State

In the power-down state the CPU stops operating to conserve power. There are three modes: sleep mode, software standby mode, and hardware standby mode.

Sleep Mode: A transition to sleep mode is made if the SLEEP instruction is executed while the SSBY bit is cleared to 0 in the system control register (SYSCR). CPU operations stop immediately after execution of the SLEEP instruction, but the contents of CPU registers are retained.

Software Standby Mode: A transition to software standby mode is made if the SLEEP instruction is executed while the SSBY bit is set to 1 in SYSCR. The CPU and clock halt and all on-chip supporting modules stop operating. The on-chip supporting modules are reset, but as long as a specified voltage is supplied the contents of CPU registers and on-chip RAM are retained. The I/O ports also remain in their existing states.

Hardware Standby Mode: A transition to hardware standby mode is made when the $\overline{\text{STBY}}$ input goes low. As in software standby mode, the CPU and all clocks halt and the on-chip supporting modules are reset, but as long as a specified voltage is supplied, on-chip RAM contents are retained.

For further information see section 19, Power-Down State.

2.9 Basic Operational Timing

2.9.1 Overview

The H8/300H CPU operates according to the system clock (ϕ). The interval from one rise of the system clock to the next rise is referred to as a “state.” A memory cycle or bus cycle consists of two or three states. The CPU uses different methods to access on-chip memory, the on-chip supporting modules, and the external address space. Access to the external address space can be controlled by the bus controller.

2.9.2 On-Chip Memory Access Timing

On-chip memory is accessed in two states. The data bus is 16 bits wide, permitting both byte and word access. Figure 2-15 shows the on-chip memory access cycle. Figure 2-16 indicates the pin states.

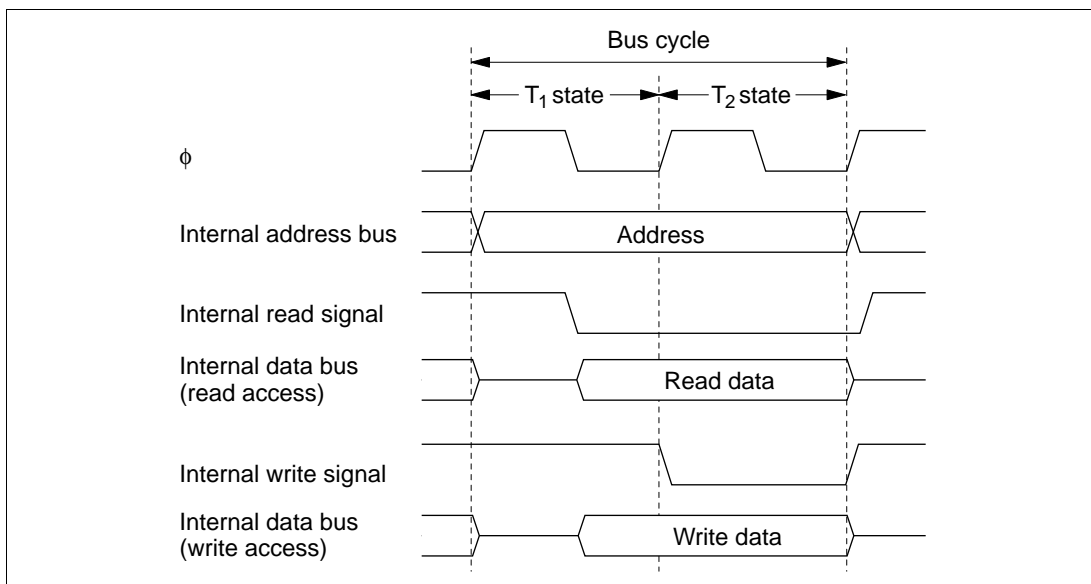

Figure 2-15 On-Chip Memory Access Cycle

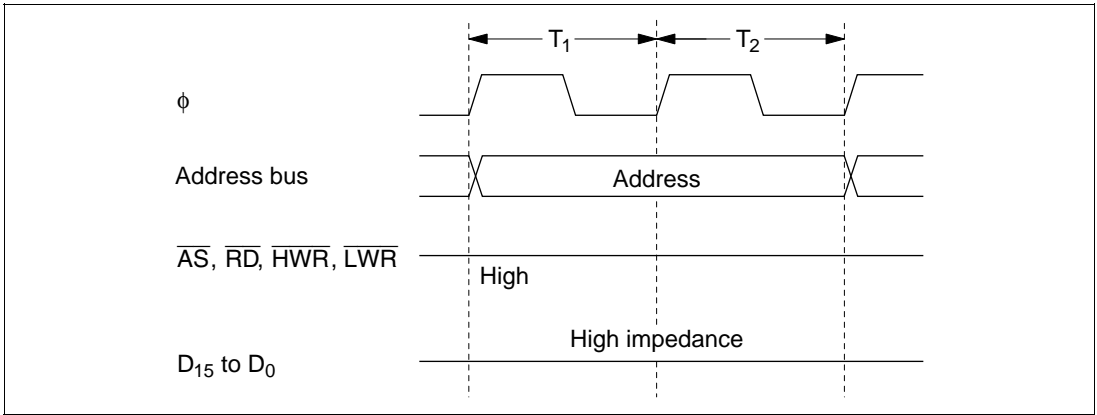

Figure 2-16 Pin States during On-Chip Memory Access

2.9.3 On-Chip Supporting Module Access Timing

The on-chip supporting modules are accessed in three states. The data bus is 8 or 16 bits wide, depending on the internal I/O register being accessed. Figure 2-17 shows the on-chip supporting module access timing. Figure 2-18 indicates the pin states.

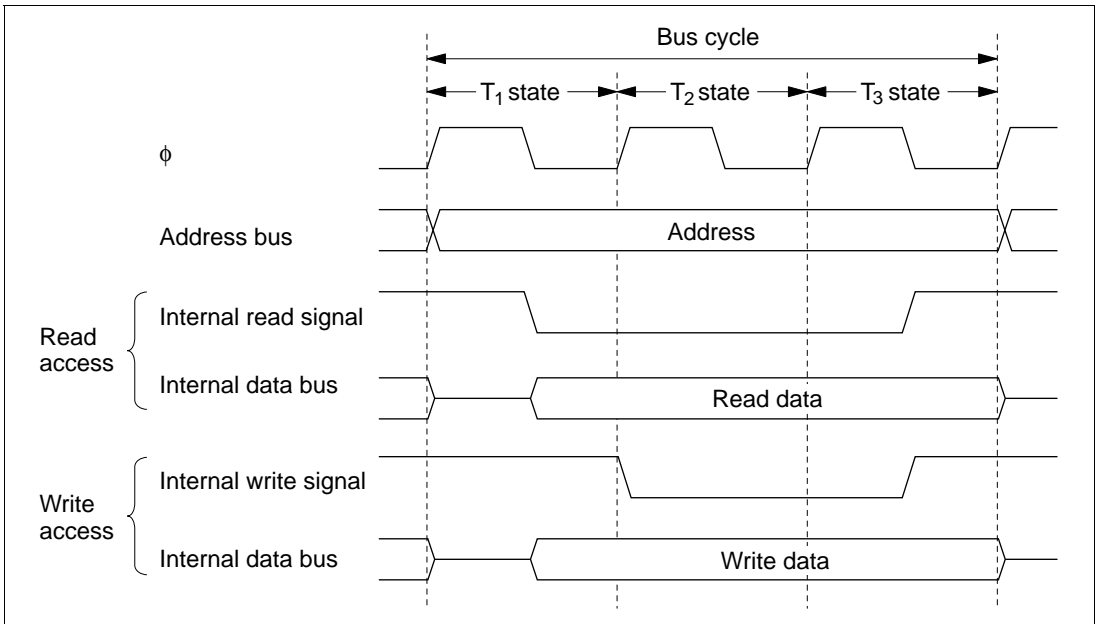

Figure 2-17 Access Cycle for On-Chip Supporting Modules

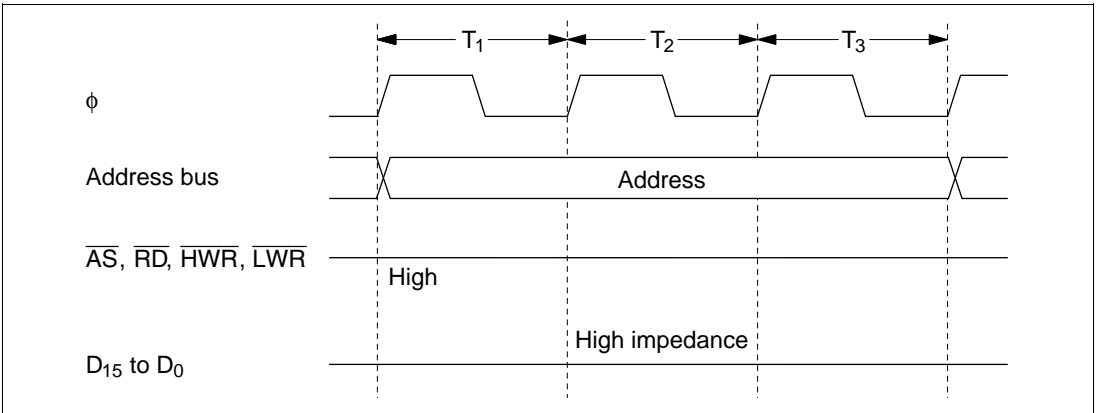

Figure 2-18 Pin States during Access to On-Chip Supporting Modules

2.9.4 Access to External Address Space

The external address space is divided into eight areas (areas 0 to 7). Bus-controller settings determine whether each area is accessed via an 8-bit or 16-bit bus, and whether it is accessed in two or three states. For details see section 6, Bus Controller.

Section 3 MCU Operating Modes

3.1 Overview

3.1.1 Operating Mode Selection

The H8/3006 and H8/3007 have four operating modes (modes 1 to 4) that are selected by the mode pins (MD₂ to MD₀) as indicated in table 3-1. The input at these pins determines the size of the address space and the initial bus mode.

Table 3-1 Operating Mode Selection

Operating Mode	Mode Pins			Description		
	MD ₂	MD ₁	MD ₀	Address Space	Initial Bus Mode* ¹	On-Chip RAM
—	0	0	0	Setting prohibited	Setting prohibited	Setting prohibited
Mode 1	0	0	1	1 Mbyte	8 bits	Enabled* ²
Mode 2	0	1	0	1 Mbyte	16 bits	Enabled* ²
Mode 3	0	1	1	16 Mbytes	8 bits	Enabled* ²
Mode 4	1	0	0	16 Mbytes	16 bits	Enabled* ²
—	1	0	1	—	—	—
—	1	1	0	—	—	—
—	1	1	1	—	—	—

- Notes: 1. In modes 1 to 4, an 8-bit or 16-bit data bus can be selected on a per-area basis by settings made in the area bus width control register (ABWCR). For details see section 6, Bus Controller.
2. If the RAME bit in SYSCR is cleared to 0, these addresses become external addresses.

For the address space size there are two choices: 1 Mbyte, or 16 Mbyte. The external data bus is either 8 or 16 bits wide depending on ABWCR settings. If 8-bit access is selected for all areas, 8-bit bus mode is used. For details see section 6, Bus Controller.

Modes 1 and 2 support a maximum address space of 1 Mbyte. Modes 3 and 4 support a maximum address space of 16 Mbytes.

The H8/3006 and H8/3007 can be used only in modes 1 to 4. The inputs at the mode pins must select one of these four modes. The inputs at the mode pins must not be changed during operation.

When changing the mode, the chip must be placed in the reset state before the mode pin inputs are changed.

3.1.2 Register Configuration

The H8/3006 and H8/3007 have a mode control register (MDCR) that indicates the inputs at the mode pins (MD_2 to MD_0), and a system control register (SYSCR). Table 3-2 summarizes these registers.

Table 3-2 Registers

Address*	Name	Abbreviation	R/W	Initial Value
H'EE011	Mode control register	MDCR	R	Undetermined
H'EE012	System control register	SYSCR	R/W	H'09

Note: * Lower 20 bits of the address in advanced mode.

3.2 Mode Control Register (MDCR)

MDCR is an 8-bit read-only register that indicates the current operating mode of the H8/3006 and H8/3007.

Bit	7	6	5	4	3	2	1	0
	—	—	—	—	—	MDS2	MDS1	MDS0
Initial value	1	1	0	0	0	—*	—*	—*
Read/Write	—	—	—	—	—	R	R	R

Reserved bits
Mode select 2 to 0
Bits indicating the current operating mode

Note: * Determined by pins MD_2 to MD_0 .

Bits 7 and 6—Reserved: These bits can not be modified and are always read as 1.

Bits 5 to 3—Reserved: These bits can not be modified and are always read as 0.

Bits 2 to 0—Mode Select 2 to 0 (MDS2 to MDS0): These bits indicate the logic levels at pins MD_2 to MD_0 (the current operating mode). MDS2 to MDS0 correspond to MD_2 to MD_0 . MDS2 to MDS0 are read-only bits. The mode pin (MD_2 to MD_0) levels are latched into these bits when MDCR is read.

3.3 System Control Register (SYSCR)

SYSCR is an 8-bit register that controls the operation of the H8/3006 and H8/3007.

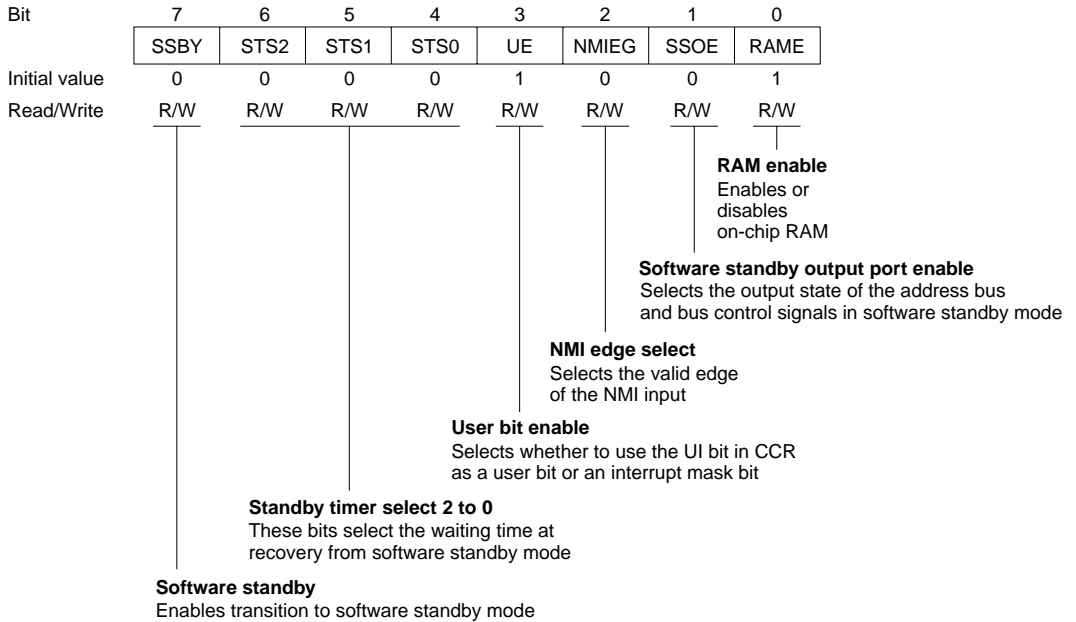

Bit 7—Software Standby (SSBY): Enables transition to software standby mode. (For further information about software standby mode see section 19, Power-Down State.)

When software standby mode is exited by an external interrupt and a transition is made to normal operation, this bit remains set to 1. To clear this bit, write 0.

Bit 7

SSBY	Description
0	SLEEP instruction causes transition to sleep mode (Initial value)
1	SLEEP instruction causes transition to software standby mode

Bits 6 to 4—Standby Timer Select 2 to 0 (STS2 to STS0): These bits select the length of time the CPU and on-chip supporting modules wait for the internal clock oscillator to settle when software standby mode is exited by an external interrupt.

When using a crystal oscillator, set these bits so that the waiting time will be at least 7 ms at the system clock rate.

For further information about waiting time selection, see section 19.4.3, Selection of Waiting Time for Exit from Software Standby Mode.

Bit 6 STS2	Bit 5 STS1	Bit 4 STS0	Description
0	0	0	Waiting time = 8,192 states (Initial value)
0	0	1	Waiting time = 16,384 states
0	1	0	Waiting time = 32,768 states
0	1	1	Waiting time = 65,536 states
1	0	0	Waiting time = 131,072 states
1	0	1	Waiting time = 262,144 states
1	1	0	Waiting time = 1,024 states
1	1	1	Illegal setting

Bit 3—User Bit Enable (UE): Selects whether to use the UI bit in the condition code register as a user bit or an interrupt mask bit.

Bit 3 UE	Description
0	UI bit in CCR is used as an interrupt mask bit
1	UI bit in CCR is used as a user bit (Initial value)

Bit 2—NMI Edge Select (NMIEG): Selects the valid edge of the NMI input.

Bit 2 NMIEG	Description
0	An interrupt is requested at the falling edge of NMI (Initial value)
1	An interrupt is requested at the rising edge of NMI

Bit 1—Software Standby Output Port Enable (SSOE): Specifies whether the address bus and bus control signals (\overline{CS}_0 to \overline{CS}_7 , \overline{AS} , \overline{RD} , \overline{HWR} , \overline{LWR} , \overline{UCAS} , \overline{LCAS} , and \overline{RFSH}) are kept as outputs or fixed high, or placed in the high-impedance state in software standby mode.

Bit 1

SSOE	Description
0	In software standby mode, the address bus and bus control signals are all high-impedance (Initial value)
1	In software standby mode, the address bus retains its output state and bus control signals are fixed high

Bit 0—RAM Enable (RAME): Enables or disables the on-chip RAM. The RAME bit is initialized by the rising edge of the \overline{RES} signal. It is not initialized in software standby mode.

Bit 0

RAME	Description
0	On-chip RAM is disabled
1	On-chip RAM is enabled (Initial value)

3.4 Operating Mode Descriptions

3.4.1 Mode 1

A maximum 1-Mbyte address space can be accessed. The initial bus mode after a reset is 8 bits, with 8-bit access to all areas. If at least one area is designated for 16-bit access in ABWCR, the bus mode switches to 16 bits.

3.4.2 Mode 2

A maximum 1-Mbyte address space can be accessed. The initial bus mode after a reset is 16 bits, with 16-bit access to all areas. If all areas are designated for 8-bit access in ABWCR, the bus mode switches to 8 bits.

3.4.3 Mode 3

Part of port A function as address pins A_{23} to A_{20} , permitting access to a maximum 16-Mbyte address space. The initial bus mode after a reset is 8 bits, with 8-bit access to all areas. If at least one area is designated for 16-bit access in ABWCR, the bus mode switches to 16 bits. A_{23} to A_{21} are valid when 0 is written in bits 7 to 5 of the bus release control register (BRCR). (In this mode A_{20} is always used for address output.)

3.4.4 Mode 4

Part of port A function as address pins A_{23} to A_{20} , permitting access to a maximum 16-Mbyte address space. The initial bus mode after a reset is 16 bits, with 16-bit access to all areas. If all areas are designated for 8-bit access in ABWCR, the bus mode switches to 8 bits. A_{23} to A_{21} are valid when 0 is written in bits 7 to 5 of BRCR. (In this mode A_{20} is always used for address output.)

3.5 Pin Functions in Each Operating Mode

The pin functions of port 4 and port A vary depending on the operating mode. Table 3-3 indicates their functions in each operating mode.

Table 3-3 Pin Functions in Each Mode

Port	Mode 1	Mode 2	Mode 3	Mode 4
Port 4	P4 ₇ to P4 ₀ ^{*1}	D ₇ to D ₀ ^{*1}	P4 ₇ to P4 ₀ ^{*1}	D ₇ to D ₀ ^{*1}
Port A	PA ₇ to PA ₄	PA ₇ to PA ₄	PA ₆ to PA ₄ , A ₂₀ ^{*2}	PA ₆ to PA ₄ , A ₂₀ ^{*2}

Notes: 1. Initial state. The bus mode can be switched by settings in ABWCR. These pins function as P4₇ to P4₀ in 8-bit bus mode, and as D₇ to D₀ in 16-bit bus mode.
2. Initial state. A₂₀ is always an address output pin. PA₆ to PA₄ are switched over to A₂₃ to A₂₁ output by writing 0 in bits 7 to 5 of BR CR.

3.6 Memory Map in Each Operating Mode

Figure 3-1, 3-2 show a memory maps of the H8/3006 and H8/3007. The address space is divided into eight areas.

The initial bus mode differs between modes 1 and 2, and also between modes 3 and 4.

The address locations of the on-chip RAM and internal I/O registers differ between the 1-Mbyte modes (modes 1, 2), and the 16-Mbyte modes (modes 3, 4). The address range specifiable by the CPU in the 8- and 16-bit absolute addressing modes (@aa:8 and @aa:16) also differs.

3.6.1 Note on Reserved Areas

The memory map of the H8/3006 and H8/3007 includes reserved areas to which read/write access is prohibited. Note that normal operation is not guaranteed if the following reserved areas are accessed.

The internal I/O register space of the H8/3006 and H8/3007 includes a reserved area to which access is prohibited. For details, see Appendix B, Internal I/O Registers.

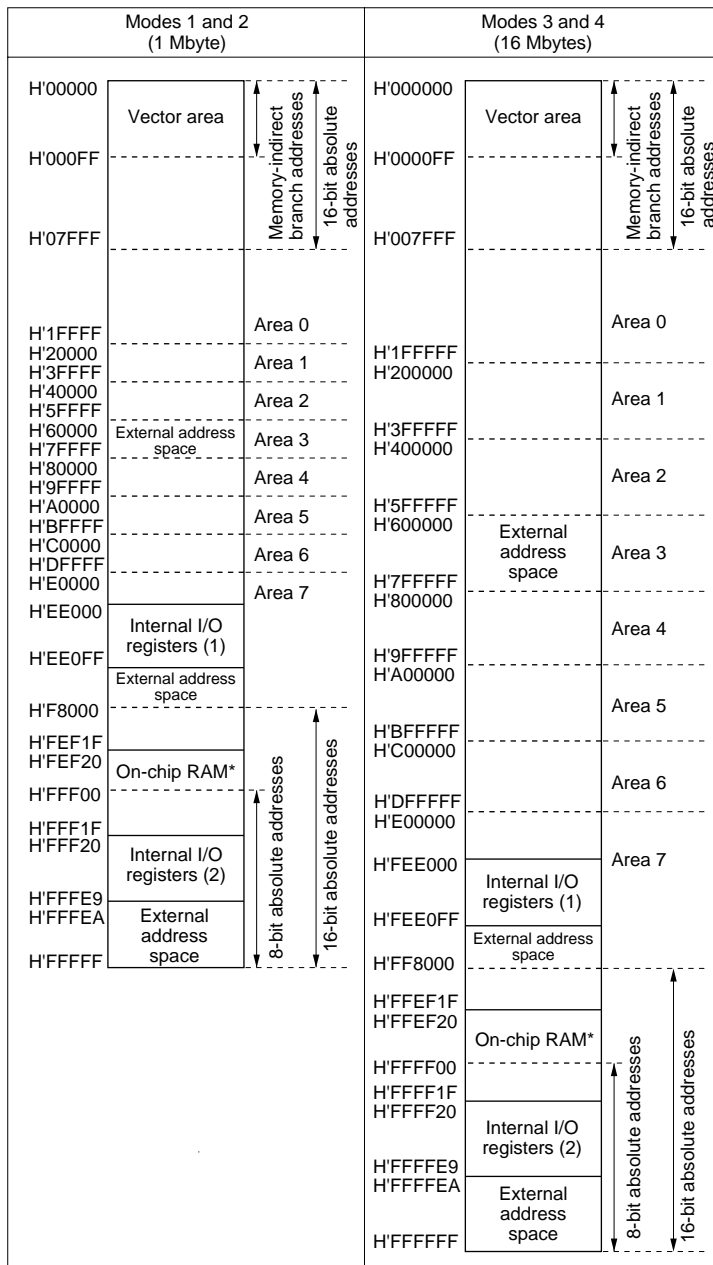

Note: * External addresses can be accessed by disabling on-chip RAM.

Figure 3-1 H8/3007 Memory Map in Each Operating Mode

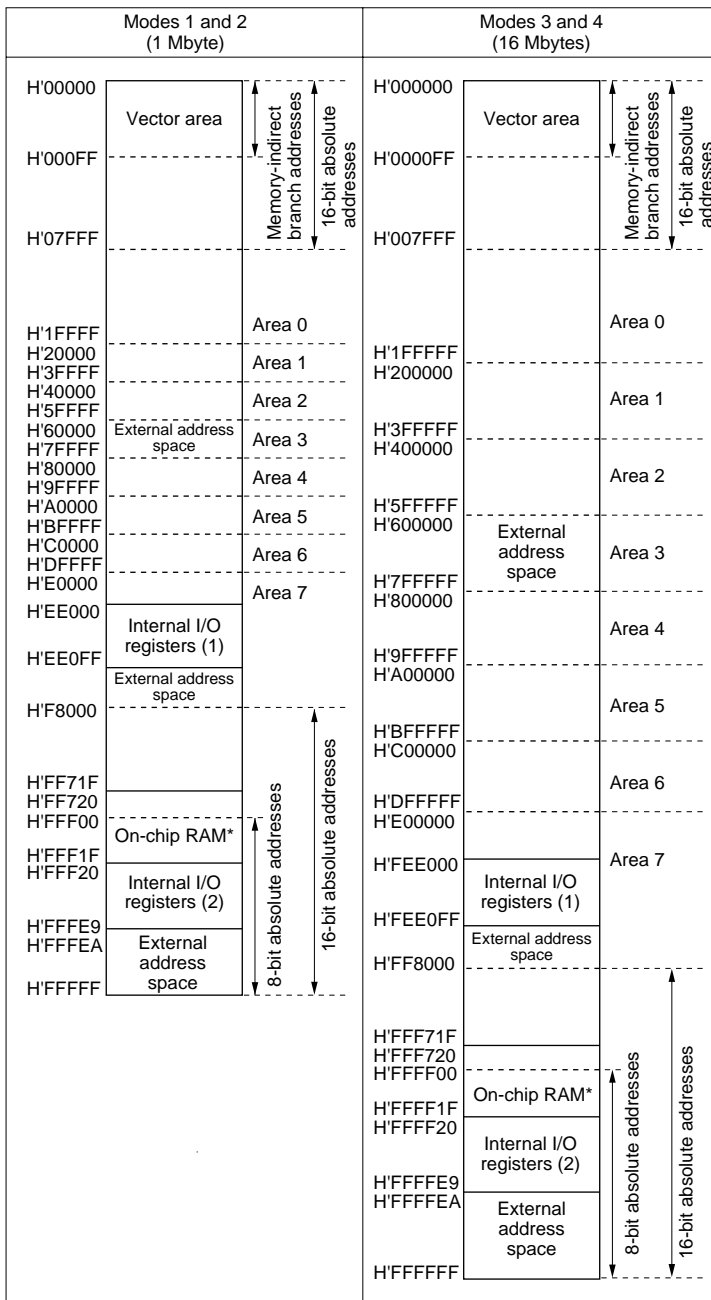

Note: * External addresses can be accessed by disabling on-chip RAM.

Figure 3-2 H8/3006 Memory Map in Each Operating Mode

Section 4 Exception Handling

4.1 Overview

4.1.1 Exception Handling Types and Priority

As table 4-1 indicates, exception handling may be caused by a reset, interrupt, or trap instruction. Exception handling is prioritized as shown in table 4-1. If two or more exceptions occur simultaneously, they are accepted and processed in priority order. Trap instruction exceptions are accepted at all times in the program execution state.

Table 4-1 Exception Types and Priority

Priority	Exception Type	Start of Exception Handling
High	Reset	Starts immediately after a low-to-high transition at the $\overline{\text{RES}}$ pin
↑	Interrupt	Interrupt requests are handled when execution of the current instruction or handling of the current exception is completed
Low	Trap instruction (TRAPA)	Started by execution of a trap instruction (TRAPA)

4.1.2 Exception Handling Operation

Exceptions originate from various sources. Trap instructions and interrupts are handled as follows.

1. The program counter (PC) and condition code register (CCR) are pushed onto the stack.
2. The CCR interrupt mask bit is set to 1.
3. A vector address corresponding to the exception source is generated, and program execution starts from that address.

Note: For a reset exception, steps 2 and 3 above are carried out.

4.1.3 Exception Vector Table

The exception sources are classified as shown in figure 4-1. Different vectors are assigned to different exception sources. Table 4-2 lists the exception sources and their vector addresses.

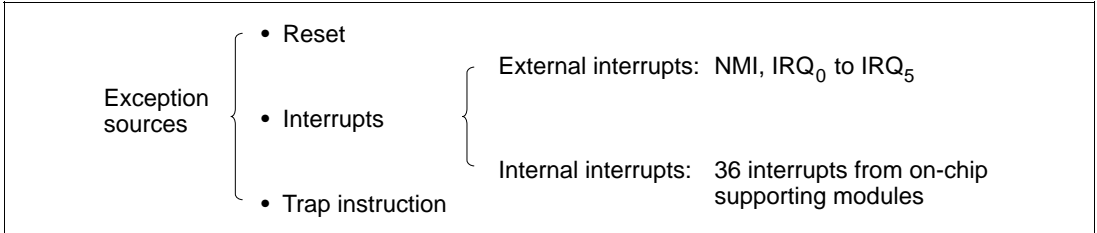

Figure 4-1 Exception Sources

Table 4-2 Exception Vector Table

Exception Source	Vector Number	Vector Address*1	
		Advanced Mode	Normal Mode*3
Reset	0	H'0000 to H'0003	H'0000 to H'0001
Reserved for system use	1	H'0004 to H'0007	H'0002 to H'0003
	2	H'0008 to H'000B	H'0004 to H'0005
	3	H'000C to H'000F	H'0006 to H'0007
	4	H'0010 to H'0013	H'0008 to H'0009
	5	H'0014 to H'0017	H'000A to H'000B
	6	H'0018 to H'001B	H'000C to H'000D
External interrupt (NMI)	7	H'001C to H'001F	H'000E to H'000F
Trap instruction (4 sources)	8	H'0020 to H'0023	H'0010 to H'0011
	9	H'0024 to H'0027	H'0012 to H'0013
	10	H'0028 to H'002B	H'0014 to H'0015
	11	H'002C to H'002F	H'0016 to H'0017
External interrupt IRQ ₀	12	H'0030 to H'0033	H'0018 to H'0019
External interrupt IRQ ₁	13	H'0034 to H'0037	H'001A to H'001B
External interrupt IRQ ₂	14	H'0038 to H'003B	H'001C to H'001D
External interrupt IRQ ₃	15	H'003C to H'003F	H'001E to H'001F
External interrupt IRQ ₄	16	H'0040 to H'0043	H'0020 to H'0021
External interrupt IRQ ₅	17	H'0044 to H'0047	H'0022 to H'0023
Reserved for system use	18	H'0048 to H'004B	H'0024 to H'0025
	19	H'004C to H'004F	H'0026 to H'0027
Internal interrupts*2	20	H'0050 to H'0053	H'0028 to H'0029
	to	to	to
	63	H'00FC to H'00FF	H'007E to H'007F

Notes: 1. Lower 16 bits of the address.

2. For the internal interrupt vectors, see section 5.3.3, Interrupt Vector Table.

3. Normal mode is not available in the H8/3006 and H8/3007.

4.2 Reset

4.2.1 Overview

A reset is the highest-priority exception. When the $\overline{\text{RES}}$ pin goes low, all processing halts and the chip enters the reset state. A reset initializes the internal state of the CPU and the registers of the on-chip supporting modules. Reset exception handling begins when the $\overline{\text{RES}}$ pin changes from low to high.

The chip can also be reset by overflow of the watchdog timer. For details see section 12, Watchdog Timer.

4.2.2 Reset Sequence

The chip enters the reset state when the $\overline{\text{RES}}$ pin goes low.

To ensure that the chip is properly reset, hold the $\overline{\text{RES}}$ pin low for at least 20 ms at power-up. To reset the chip during operation, hold the $\overline{\text{RES}}$ pin low for at least 10 system clock (ϕ) cycles. See appendix D.2, Pin States at Reset, for the states of the pins in the reset state.

When the $\overline{\text{RES}}$ pin goes high after being held low for the necessary time, the chip starts reset exception handling as follows.

- The internal state of the CPU and the registers of the on-chip supporting modules are initialized, and the I bit is set to 1 in CCR.
- The contents of the reset vector address (H'0000 to H'0003) are read, and program execution starts from the address indicated in the vector address.

Figure 4-2 shows the reset sequence in modes 1 and 3. Figure 4-3 shows the reset sequence in modes 2 and 4.

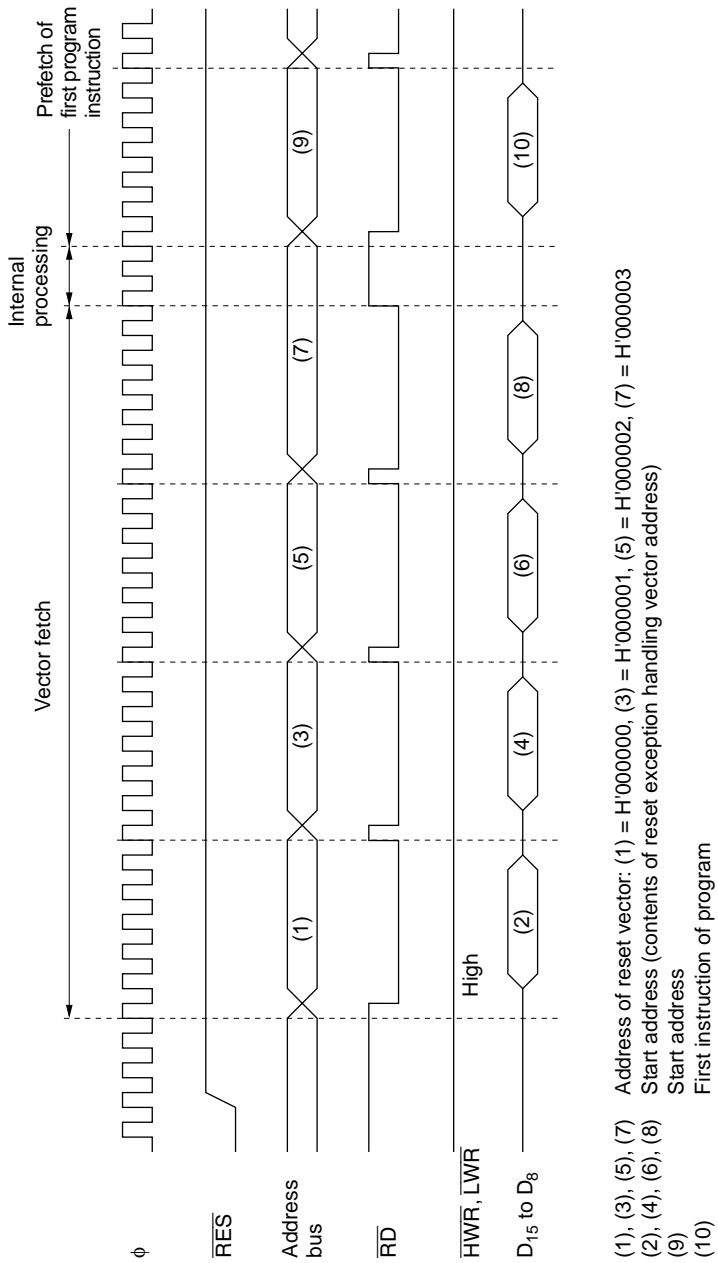

Figure 4-2 Reset Sequence (Modes 1 and 3)

Note: After a reset, the wait-state controller inserts three wait states in every bus cycle.

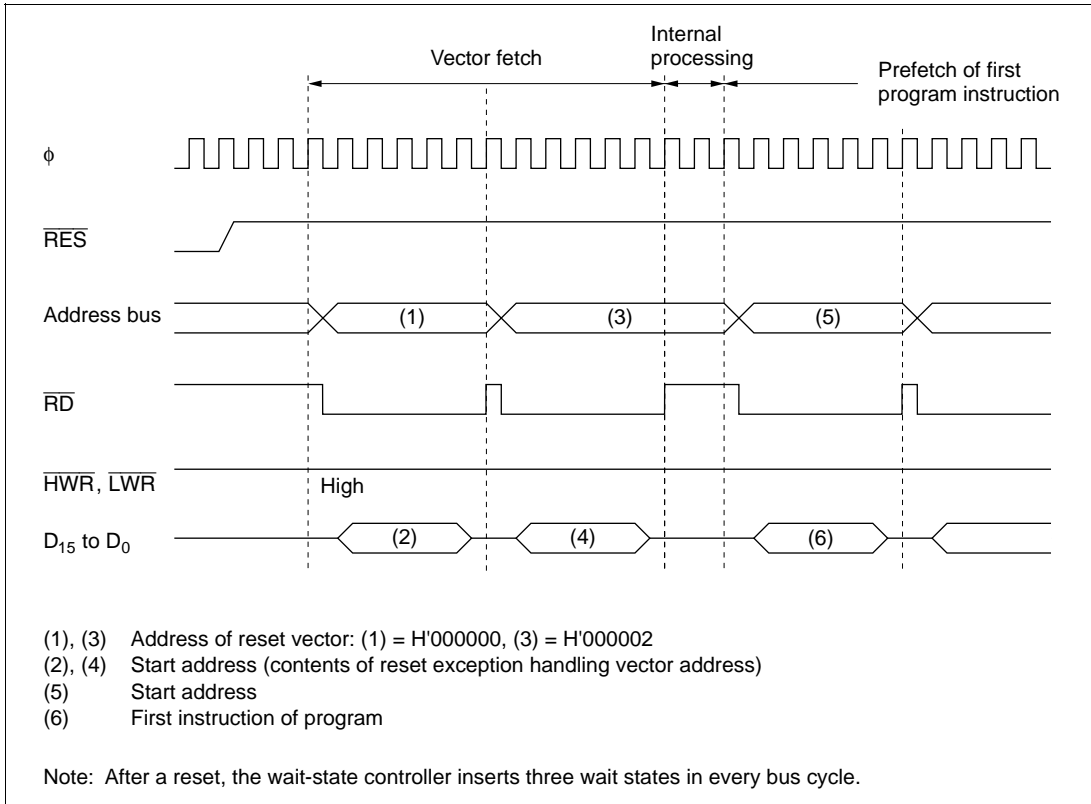

Figure 4-3 Reset Sequence (Modes 2 and 4)

4.2.3 Interrupts after Reset

If an interrupt is accepted after a reset but before the stack pointer (SP) is initialized, PC and CCR will not be saved correctly, leading to a program crash. To prevent this, all interrupt requests, including NMI, are disabled immediately after a reset. The first instruction of the program is always executed immediately after the reset state ends. This instruction should initialize the stack pointer (example: MOV.L #xx:32, SP).

4.3 Interrupts

Interrupt exception handling can be requested by seven external sources (NMI, IRQ₀ to IRQ₅), and 36 internal sources in the on-chip supporting modules. Figure 4-4 classifies the interrupt sources and indicates the number of interrupts of each type.

The on-chip supporting modules that can request interrupts are the watchdog timer (WDT), DRAM interface, 16-bit timer, 8-bit timer, DMA controller (DMAC), serial communication interface (SCI), and A/D converter. Each interrupt source has a separate vector address.

NMI is the highest-priority interrupt and is always accepted. Interrupts are controlled by the interrupt controller. The interrupt controller can assign interrupts other than NMI to two priority levels, and arbitrate between simultaneous interrupts. Interrupt priorities are assigned in interrupt priority registers A and B (IPRA and IPRB) in the interrupt controller.

For details on interrupts see section 5, Interrupt Controller.

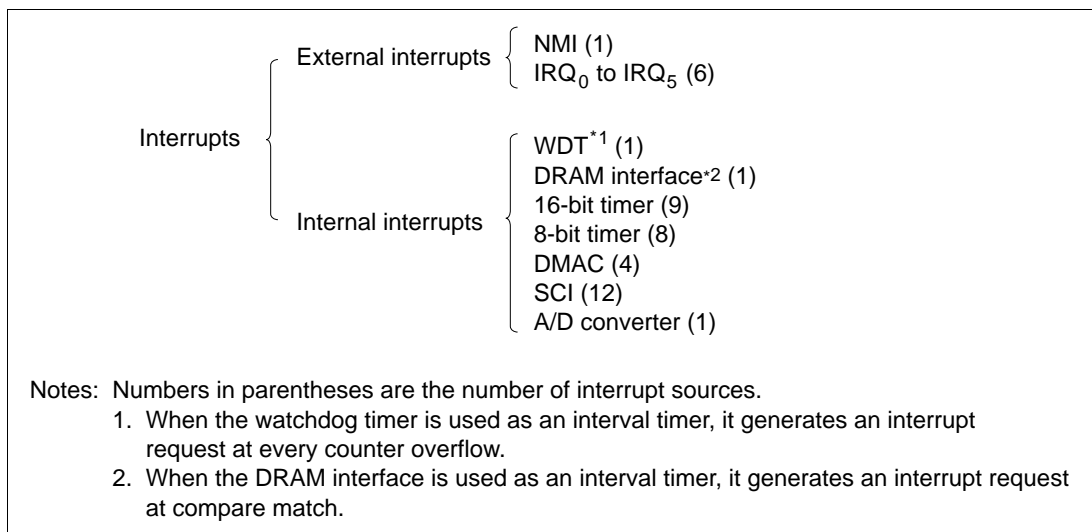

Figure 4-4 Interrupt Sources and Number of Interrupts

4.4 Trap Instruction

Trap instruction exception handling starts when a TRAPA instruction is executed. If the UE bit is set to 1 in the system control register (SYSCR), the exception handling sequence sets the I bit to 1 in CCR. If the UE bit is 0, the I and UI bits are both set to 1. The TRAPA instruction fetches a start address from a vector table entry corresponding to a vector number from 0 to 3, which is specified in the instruction code.

4.5 Stack Status after Exception Handling

Figure 4-5 shows the stack after completion of trap instruction exception handling and interrupt exception handling.

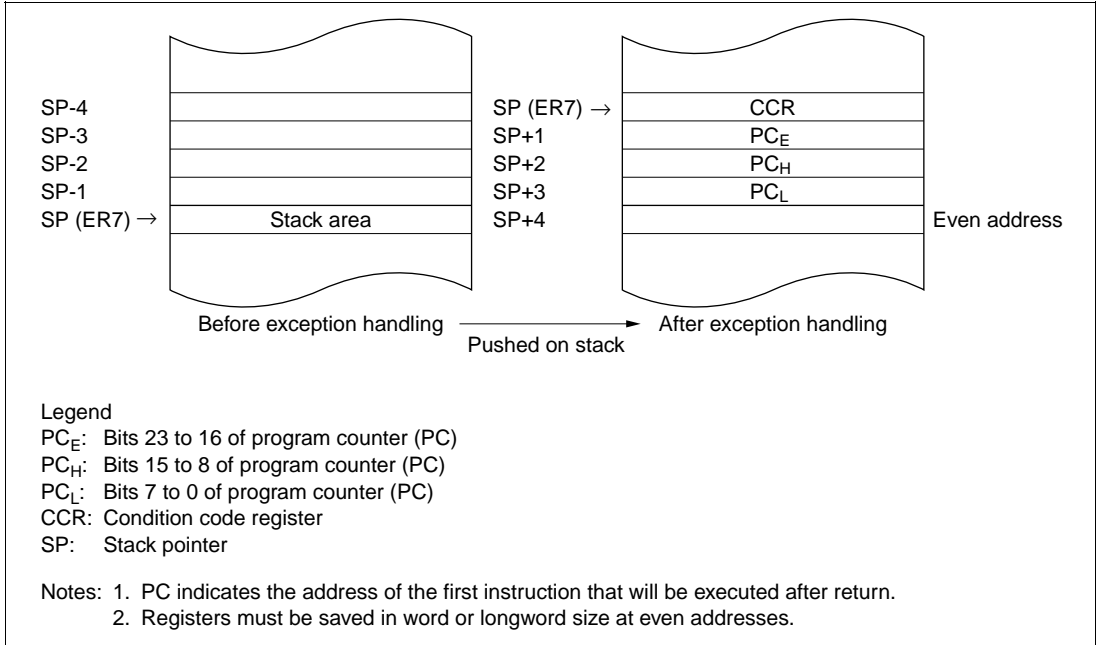

Figure 4-5 Stack after Completion of Exception Handling

4.6 Notes on Stack Usage

When accessing word data or longword data, the H8/3006 and H8/3007 regards the lowest address bit as 0. The stack should always be accessed by word access or longword access, and the value of the stack pointer (SP: ER7) should always be kept even.

Use the following instructions to save registers:

PUSH.W Rn (MOV.W Rn, @-SP)

PUSH.L ERn (MOV.L ERn, @-SP)

Use the following instructions to restore registers:

POP.W Rn (MOV.W @SP+, Rn)

POP.L ERn (MOV.L @SP+, ERn)

Setting SP to an odd value may lead to a malfunction. Figure 4-6 shows an example of what happens when the SP value is odd.

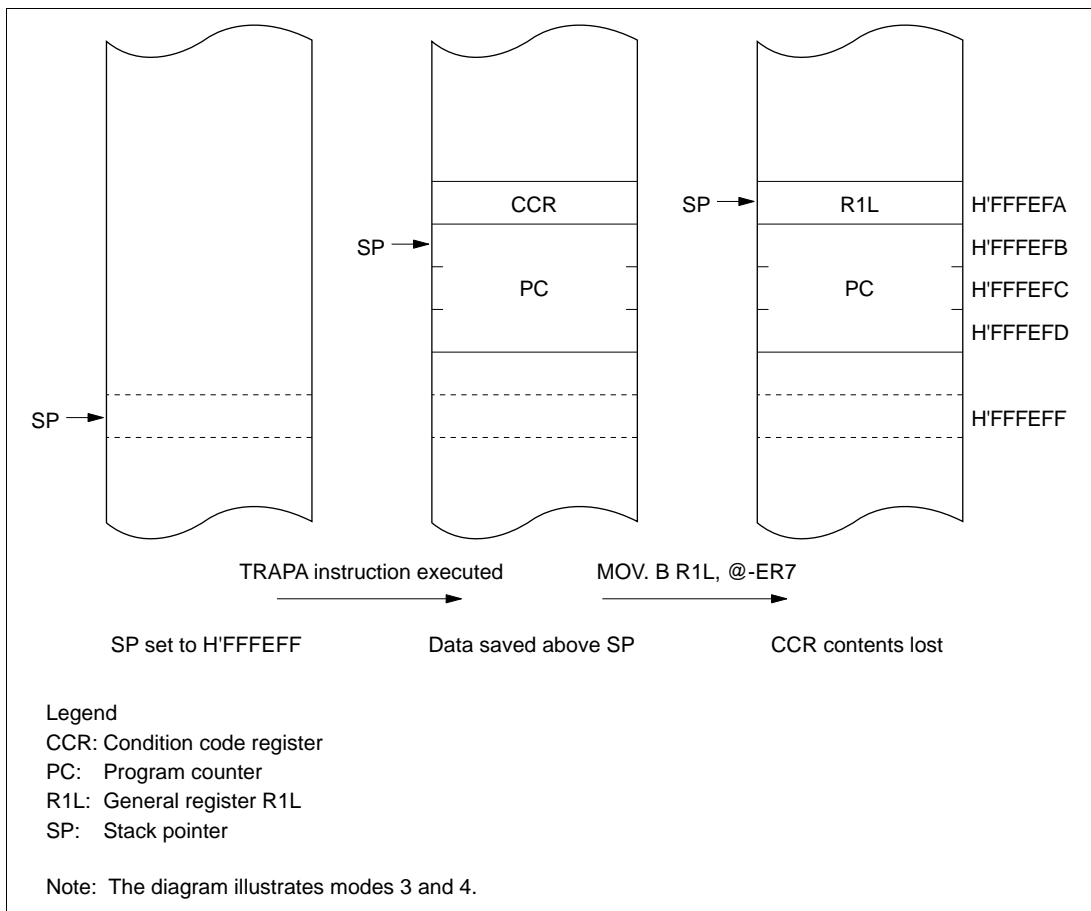

Figure 4-6 Operation when SP Value is Odd

Section 5 Interrupt Controller

5.1 Overview

5.1.1 Features

The interrupt controller has the following features:

- Interrupt priority registers (IPRs) for setting interrupt priorities
Interrupts other than NMI can be assigned to two priority levels on a module-by-module basis in interrupt priority registers A and B (IPRA and IPRB).
- Three-level enable/disable state setting possible by means of the I and UI bits in the CPU's condition code register (CCR) and the UE bit in the system control register (SYSCR)
- Seven external interrupt pins
NMI has the highest priority and is always accepted; either the rising or falling edge can be selected. For each of IRQ_0 to IRQ_5 , sensing of the falling edge or level sensing can be selected independently.

5.1.2 Block Diagram

Figure 5-1 shows a block diagram of the interrupt controller.

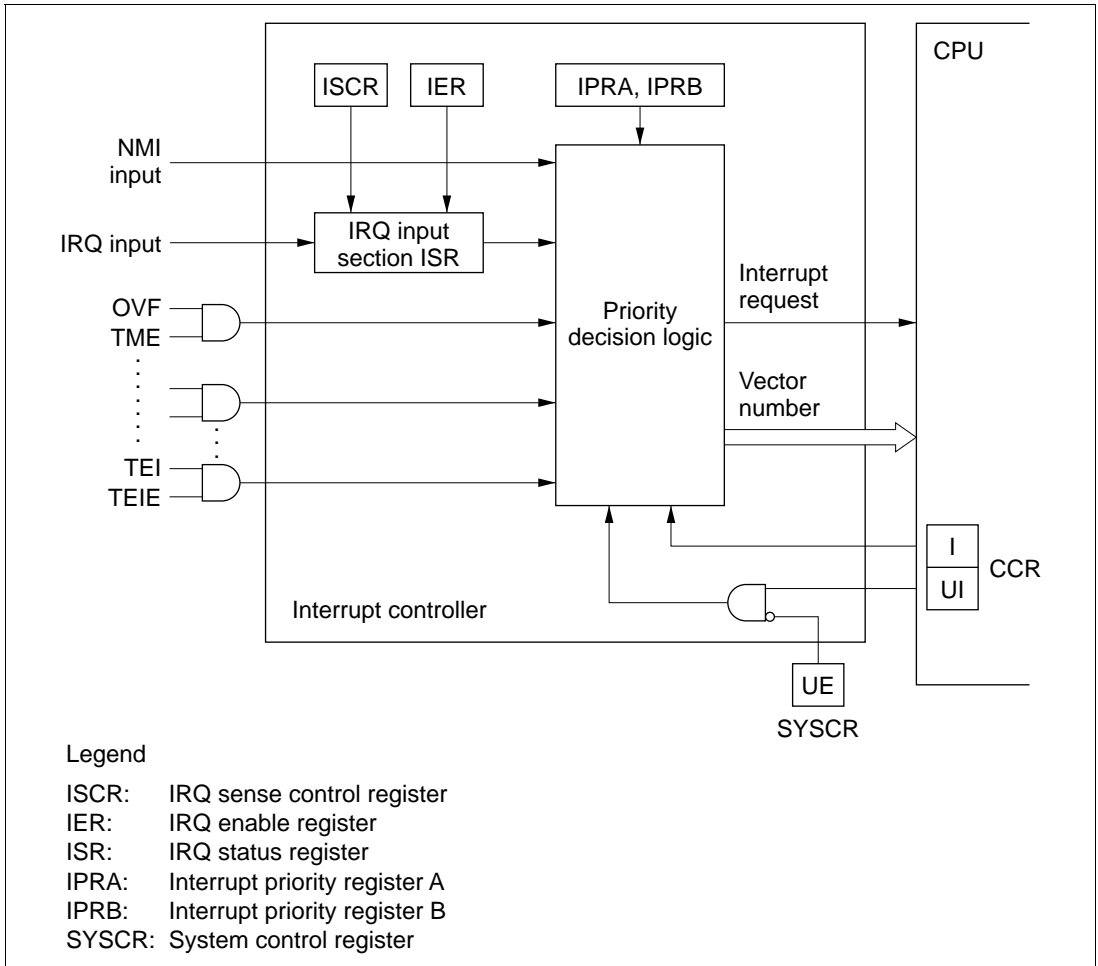

Figure 5-1 Interrupt Controller Block Diagram

5.1.3 Pin Configuration

Table 5-1 lists the interrupt pins.

Table 5-1 Interrupt Pins

Name	Abbreviation	I/O	Function
Nonmaskable interrupt	NMI	Input	Nonmaskable interrupt, rising edge or falling edge selectable
External interrupt request 5 to 0	$\overline{\text{IRQ}}_5$ to $\overline{\text{IRQ}}_0$	Input	Maskable interrupts, falling edge or level sensing selectable

5.1.4 Register Configuration

Table 5-2 lists the registers of the interrupt controller.

Table 5-2 Interrupt Controller Registers

Address* ¹	Name	Abbreviation	R/W	Initial Value
H'EE012	System control register	SYSCR	R/W	H'09
H'EE014	IRQ sense control register	ISCR	R/W	H'00
H'EE015	IRQ enable register	IER	R/W	H'00
H'EE016	IRQ status register	ISR	R/(W)* ²	H'00
H'EE018	Interrupt priority register A	IPRA	R/W	H'00
H'EE019	Interrupt priority register B	IPRB	R/W	H'00

Notes: 1. Lower 20 bits of the address in advanced mode.

2. Only 0 can be written, to clear flags.

5.2 Register Descriptions

5.2.1 System Control Register (SYSCR)

SYSCR is an 8-bit readable/writable register that controls software standby mode, selects the action of the UI bit in CCR, selects the NMI edge, and enables or disables the on-chip RAM.

Only bits 3 and 2 are described here. For the other bits, see section 3.3, System Control Register (SYSCR).

SYSCR is initialized to H'09 by a reset and in hardware standby mode. It is not initialized in software standby mode.

Bit	7	6	5	4	3	2	1	0
	SSBY	STS2	STS1	STS0	UE	NMIEG	SSOE	RAME
Initial value	0	0	0	0	1	0	0	1
Read/Write	R/W	R/W	R/W	R/W	R/W	R/W	R/W	R/W

Software standby

Standby timer select 2 to 0

User bit enable

Selects whether to use the UI bit in CCR as a user bit or interrupt mask bit

NMI edge select

Selects the NMI input edge

Software standby output port enable

RAM enable

Bit 3—User Bit Enable (UE): Selects whether to use the UI bit in CCR as a user bit or an interrupt mask bit.

Bit 3

UE	Description	
0	UI bit in CCR is used as interrupt mask bit	
1	UI bit in CCR is used as user bit	(Initial value)

Bit 2—NMI Edge Select (NMIEG): Selects the NMI input edge.

Bit 2

NMIEG	Description	
0	Interrupt is requested at falling edge of NMI input	(Initial value)
1	Interrupt is requested at rising edge of NMI input	

5.2.2 Interrupt Priority Registers A and B (IPRA, IPRB)

IPRA and IPRB are 8-bit readable/writable registers that control interrupt priority.

Interrupt Priority Register A (IPRA): IPRA is an 8-bit readable/writable register in which interrupt priority levels can be set.

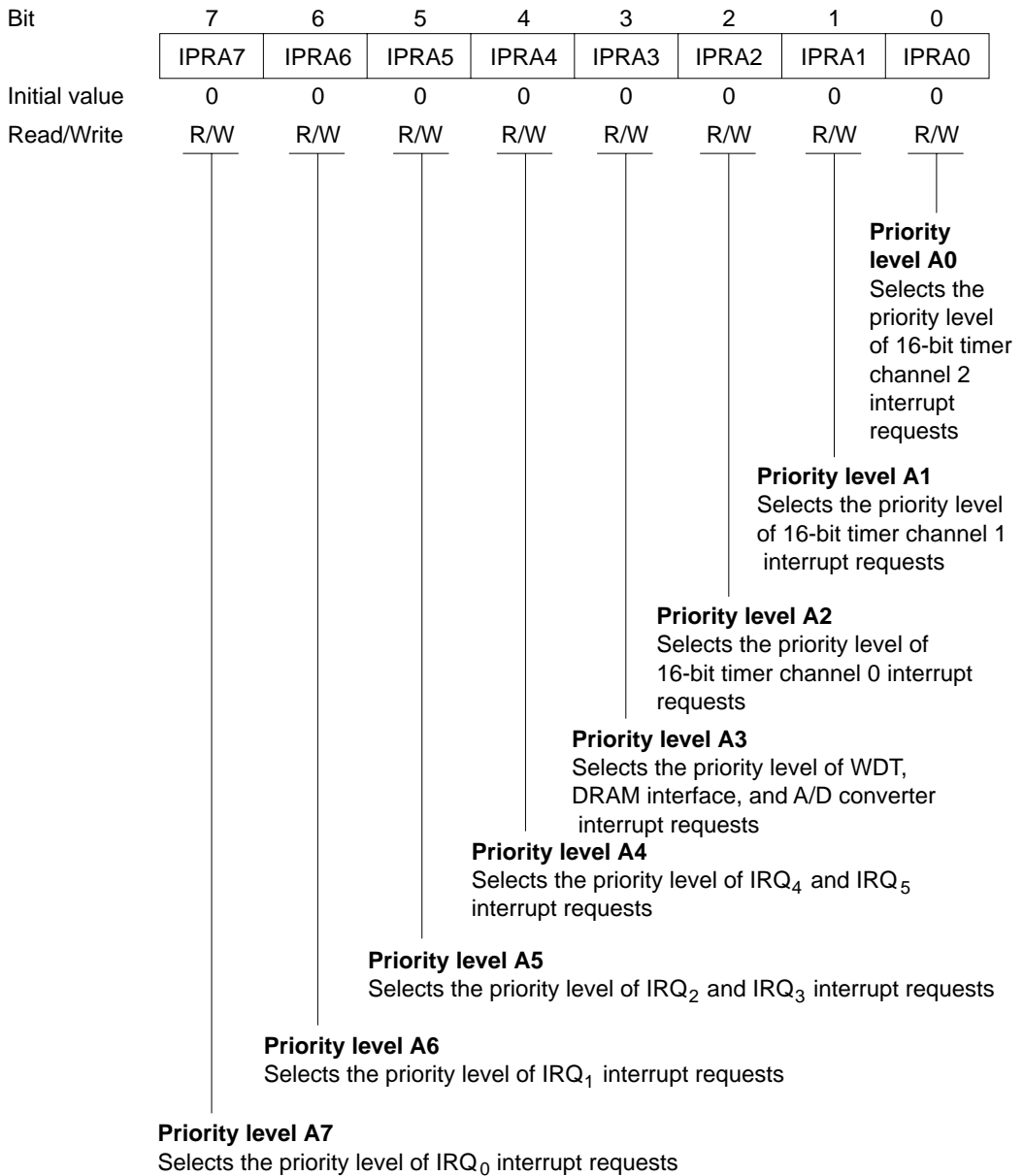

IPRA is initialized to H'00 by a reset and in hardware standby mode.

Bit 7—Priority Level A7 (IPRA7): Selects the priority level of IRQ₀ interrupt requests.

Bit 7

IPRA7	Description	
0	IRQ ₀ interrupt requests have priority level 0 (low priority)	(Initial value)
1	IRQ ₀ interrupt requests have priority level 1 (high priority)	

Bit 6—Priority Level A6 (IPRA6): Selects the priority level of IRQ₁ interrupt requests.

Bit 6

IPRA6	Description	
0	IRQ ₁ interrupt requests have priority level 0 (low priority)	(Initial value)
1	IRQ ₁ interrupt requests have priority level 1 (high priority)	

Bit 5—Priority Level A5 (IPRA5): Selects the priority level of IRQ₂ and IRQ₃ interrupt requests.

Bit 5

IPRA5	Description	
0	IRQ ₂ and IRQ ₃ interrupt requests have priority level 0 (low priority)	(Initial value)
1	IRQ ₂ and IRQ ₃ interrupt requests have priority level 1 (high priority)	

Bit 4—Priority Level A4 (IPRA4): Selects the priority level of IRQ₄ and IRQ₅ interrupt requests.

Bit 4

IPRA4	Description	
0	IRQ ₄ and IRQ ₅ interrupt requests have priority level 0 (low priority)	(Initial value)
1	IRQ ₄ and IRQ ₅ interrupt requests have priority level 1 (high priority)	

Bit 3—Priority Level A3 (IPRA3): Selects the priority level of WDT, DRAM interface, and A/D converter interrupt requests.

Bit 3

IPRA3 Description

0	WDT, DRAM interface, and A/D converter interrupt requests have priority level 0 (low priority) (Initial value)
1	WDT, DRAM interface, and A/D converter interrupt requests have priority level 1 (high priority)

Bit 2—Priority Level A2 (IPRA2): Selects the priority level of 16-bit timer channel 0 interrupt requests.

Bit 2

IPRA2 Description

0	16-bit timer channel 0 interrupt requests have priority level 0 (low priority) (Initial value)
1	16-bit timer channel 0 interrupt requests have priority level 1 (high priority)

Bit 1—Priority Level A1 (IPRA1): Selects the priority level of 16-bit timer channel 1 interrupt requests.

Bit 1

IPRA1 Description

0	16-bit timer channel 1 interrupt requests have priority level 0 (low priority) (Initial value)
1	16-bit timer channel 1 interrupt requests have priority level 1 (high priority)

Bit 0—Priority Level A0 (IPRA0): Selects the priority level of 16-bit timer channel 2 interrupt requests.

Bit 0

IPRA0 Description

0	16-bit timer channel 2 interrupt requests have priority level 0 (low priority) (Initial value)
1	16-bit timer channel 2 interrupt requests have priority level 1 (high priority)

Interrupt Priority Register B (IPRB): IPRB is an 8-bit readable/writable register in which interrupt priority levels can be set.

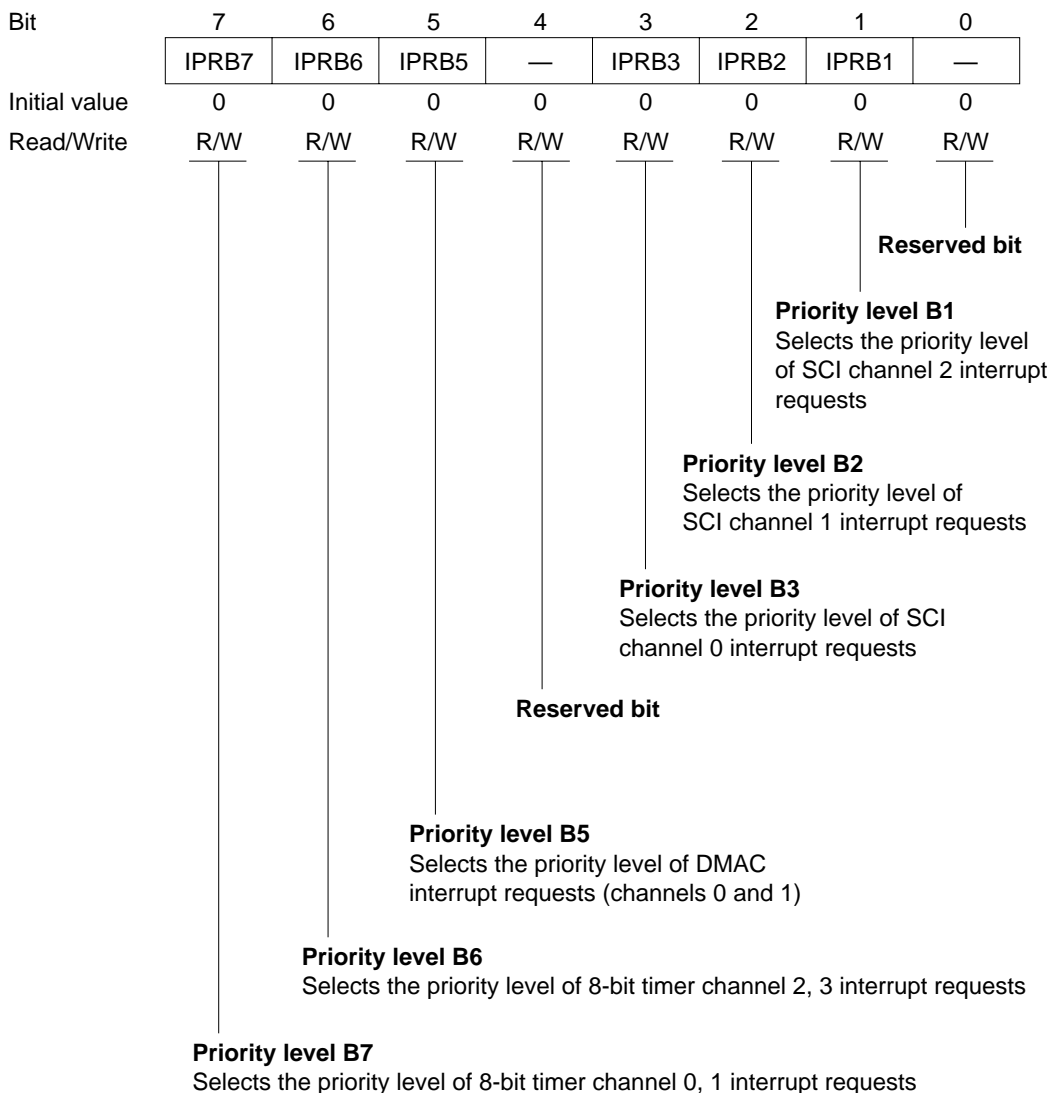

IPRB is initialized to H'00 by a reset and in hardware standby mode.

Bit 7—Priority Level B7 (IPRB7): Selects the priority level of 8-bit timer channel 0, 1 interrupt requests.

Bit 7

IPRB7	Description
0	8-bit timer channel 0, 1 interrupt requests have priority level 0 (low priority)(Initial value)
1	8-bit timer channel 0, 1 interrupt requests have priority level 1 (high priority)

Bit 6—Priority Level B6 (IPRB6): Selects the priority level of 8-bit timer channel 2, 3 interrupt requests.

Bit 6

IPRB6	Description
0	8-bit timer channel 2, 3 interrupt requests have priority level 0 (low priority)(Initial value)
1	8-bit timer channel 2, 3 interrupt requests have priority level 1 (high priority)

Bit 5—Priority Level B5 (IPRB5): Selects the priority level of DMAC interrupt requests (channels 0 and 1).

Bit 5

IPRB5	Description
0	DMAC interrupt requests (channels 0 and 1) have priority level 0 (Initial value) (low priority)
1	DMAC interrupt requests (channels 0 and 1) have priority level 1 (high priority)

Bit 4—Reserved: This bit can be written and read, but it does not affect interrupt priority.

Bit 3—Priority Level B3 (IPRB3): Selects the priority level of SCI channel 0 interrupt requests.

Bit 3

IPRB3	Description	
0	SCI0 interrupt requests have priority level 0 (low priority)	(Initial value)
1	SCI0 interrupt requests have priority level 1 (high priority)	

Bit 2—Priority Level B2 (IPRB2): Selects the priority level of SCI channel 1 interrupt requests.

Bit 2

IPRB2	Description	
0	SCI1 interrupt requests have priority level 0 (low priority)	(Initial value)
1	SCI1 interrupt requests have priority level 1 (high priority)	

Bit 1—Priority Level B1 (IPRB1): Selects the priority level of SCI channel 2 interrupt requests.

Bit 1

IPRB1	Description	
0	SCI channel 2 interrupt requests have priority level 0 (low priority)	(Initial value)
1	SCI channel 2 interrupt requests have priority level 1 (high priority)	

Bit 0—Reserved: This bit can be written and read, but it does not affect interrupt priority.

5.2.3 IRQ Status Register (ISR)

ISR is an 8-bit readable/writable register that indicates the status of IRQ₀ to IRQ₅ interrupt requests.

Bit	7	6	5	4	3	2	1	0
	—	—	IRQ5F	IRQ4F	IRQ3F	IRQ2F	IRQ1F	IRQ0F
Initial value	0	0	0	0	0	0	0	0
Read/Write	—	—	R/(W)*	R/(W)*	R/(W)*	R/(W)*	R/(W)*	R/(W)*

Reserved bits

IRQ₅ to IRQ₀ flags

These bits indicate IRQ₅ to IRQ₀ interrupt request status

Note: * Only 0 can be written, to clear flags.

ISR is initialized to H'00 by a reset and in hardware standby mode.

Bits 7 and 6—Reserved: These bits can not be modified and are always read as 0.

Bits 5 to 0—IRQ₅ to IRQ₀ Flags (IRQ5F to IRQ0F): These bits indicate the status of IRQ₅ to IRQ₀ interrupt requests.

Bits 5 to 0

IRQ5F to IRQ0F Description

0	[Clearing conditions]	(Initial value)
	<ul style="list-style-type: none"> 0 is written in IRQ_nF after reading the IRQ_nF flag when IRQ_nF = 1. IRQ_nSC = 0, $\overline{\text{IRQn}}$ input is high, and interrupt exception handling is carried out. IRQ_nSC = 1 and IRQ_n interrupt exception handling is carried out. 	
1	[Setting conditions]	
	<ul style="list-style-type: none"> IRQ_nSC = 0 and $\overline{\text{IRQn}}$ input is low. IRQ_nSC = 1 and $\overline{\text{IRQn}}$ input changes from high to low. 	

Note: n = 5 to 0

5.2.4 IRQ Enable Register (IER)

IER is an 8-bit readable/writable register that enables or disables IRQ₀ to IRQ₅ interrupt requests.

Bit	7	6	5	4	3	2	1	0
	—	—	IRQ5E	IRQ4E	IRQ3E	IRQ2E	IRQ1E	IRQ0E
Initial value	0	0	0	0	0	0	0	0
Read/Write	R/W	R/W	R/W	R/W	R/W	R/W	R/W	R/W

Reserved bits
IRQ₅ to IRQ₀ enable
 These bits enable or disable IRQ₅ to IRQ₀ interrupts

IER is initialized to H'00 by a reset and in hardware standby mode.

Bits 7 and 6—Reserved: These bits can be written and read, but they do not enable or disable interrupts.

Bits 5 to 0—IRQ₅ to IRQ₀ Enable (IRQ5E to IRQ0E): These bits enable or disable IRQ₅ to IRQ₀ interrupts.

Bits 5 to 0

IRQ5E to IRQ0E Description

0	IRQ ₅ to IRQ ₀ interrupts are disabled	(Initial value)
1	IRQ ₅ to IRQ ₀ interrupts are enabled	

5.2.5 IRQ Sense Control Register (ISCR)

ISCR is an 8-bit readable/writable register that selects level sensing or falling-edge sensing of the inputs at pins $\overline{\text{IRQ}}_5$ to $\overline{\text{IRQ}}_0$.

Bit	7	6	5	4	3	2	1	0
	—	—	IRQ5SC	IRQ4SC	IRQ3SC	IRQ2SC	IRQ1SC	IRQ0SC
Initial value	0	0	0	0	0	0	0	0
Read/Write	R/W	R/W	R/W	R/W	R/W	R/W	R/W	R/W

Reserved bits
IRQ₅ to IRQ₀ sense control
 These bits select level sensing or falling-edge sensing for IRQ₅ to IRQ₀ interrupts

ISCR is initialized to H'00 by a reset and in hardware standby mode.

Bits 7 and 6—Reserved: These bits can be written and read, but they do not select level or falling-edge sensing.

Bits 5 to 0—IRQ₅ to IRQ₀ Sense Control (IRQ5SC to IRQ0SC): These bits select whether interrupts IRQ₅ to IRQ₀ are requested by level sensing of pins $\overline{\text{IRQ}}_5$ to $\overline{\text{IRQ}}_0$, or by falling-edge sensing.

Bits 5 to 0

IRQ5SC to IRQ0SC Description

0	Interrupts are requested when $\overline{\text{IRQ}}_5$ to $\overline{\text{IRQ}}_0$ inputs are low	(Initial value)
1	Interrupts are requested by falling-edge input at $\overline{\text{IRQ}}_5$ to $\overline{\text{IRQ}}_0$	

5.3 Interrupt Sources

The interrupt sources include external interrupts (NMI, IRQ_0 to IRQ_5) and 36 internal interrupts.

5.3.1 External Interrupts

There are seven external interrupts: NMI, and IRQ_0 to IRQ_5 . Of these, NMI, IRQ_0 , IRQ_1 , and IRQ_2 can be used to exit software standby mode.

NMI: NMI is the highest-priority interrupt and is always accepted, regardless of the states of the I and UI bits in CCR. The NMIEG bit in SYSCR selects whether an interrupt is requested by the rising or falling edge of the input at the NMI pin. NMI interrupt exception handling has vector number 7.

IRQ_0 to IRQ_5 Interrupts: These interrupts are requested by input signals at pins \overline{IRQ}_0 to \overline{IRQ}_5 . The IRQ_0 to IRQ_5 interrupts have the following features.

- ISCR settings can select whether an interrupt is requested by the low level of the input at pins \overline{IRQ}_0 to \overline{IRQ}_5 , or by the falling edge.
- IER settings can enable or disable the IRQ_0 to IRQ_5 interrupts. Interrupt priority levels can be assigned by four bits in IPRA (IPRA7 to IPRA4).
- The status of IRQ_0 to IRQ_5 interrupt requests is indicated in ISR. The ISR flags can be cleared to 0 by software.

Figure 5-2 shows a block diagram of interrupts IRQ_0 to IRQ_5 .

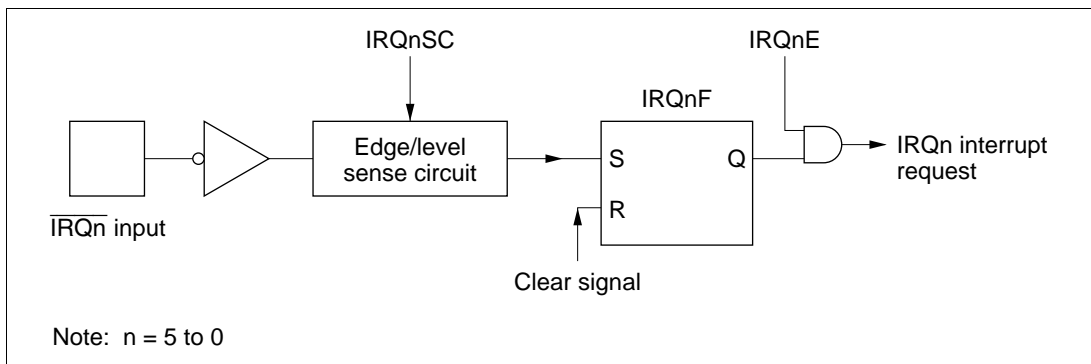

Figure 5-2 Block Diagram of Interrupts IRQ_0 to IRQ_5

Figure 5-3 shows the timing of the setting of the interrupt flags (IRQnF).

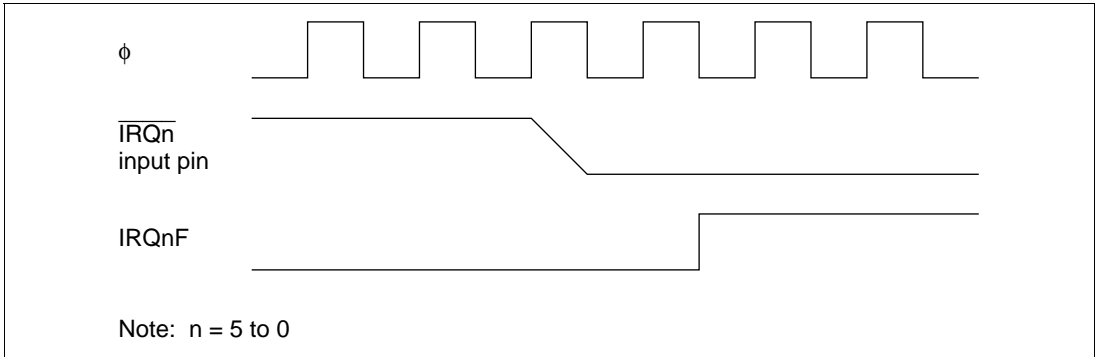

Figure 5-3 Timing of Setting of IRQnF

Interrupts IRQ_0 to IRQ_5 have vector numbers 12 to 17. These interrupts are detected regardless of whether the corresponding pin is set for input or output. When using a pin for external interrupt input, clear its DDR bit to 0 and do not use the pin for chip select output, refresh output, SCI input/output, or A/D external trigger input.

5.3.2 Internal Interrupts

Thirty-Six internal interrupts are requested from the on-chip supporting modules.

- Each on-chip supporting module has status flags for indicating interrupt status, and enable bits for enabling or disabling interrupts.
- Interrupt priority levels can be assigned in IPRA and IPRB.
- 16-bit timer, SCI, and A/D converter interrupt requests can activate the DMAC, in which case no interrupt request is sent to the interrupt controller, and the I and UI bits are disregarded.

5.3.3 Interrupt Vector Table

Table 5-3 lists the interrupt sources, their vector addresses, and their default priority order. In the default priority order, smaller vector numbers have higher priority. The priority of interrupts other than NMI can be changed in IPRA and IPRB. The priority order after a reset is the default order shown in table 5-3.

Table 5-3 Interrupt Sources, Vector Addresses, and Priority

Interrupt Source	Origin	Vector Number	Vector Address*		Priority
			Advanced Mode	IPR	
NMI	External pins	7	H'001C to H'001F	—	High ↑
IRQ ₀		12	H'0030 to H'0033	IPRA7	
IRQ ₁		13	H'0034 to H'0037	IPRA6	
IRQ ₂		14	H'0038 to H'003B	IPRA5	
IRQ ₃		15	H'003C to H'003F		
IRQ ₄ IRQ ₅		16 17	H'0040 to H'0043 H'0044 to H'0047	IPRA4	
Reserved	—	18	H'0048 to H'004B		
		19	H'004C to H'004F		
WOVI (interval timer)	Watchdog timer	20	H'0050 to H'0053	IPRA3	
CMI (compare match)	DRAM interface	21	H'0054 to H'0057		
Reserved	—	22	H'0058 to H'005B		
ADI (A/D end)	A/D	23	H'005E to H'005F		
IMIA0 (compare match/ input capture A0)	16-bit timer channel 0	24	H'0060 to H'0063	IPRA2	
IMIB0 (compare match/ input capture B0)		25	H'0064 to H'0067		
OVI0 (overflow 0)		26	H'0068 to H'006B		
Reserved	—	27	H'006C to H'006F		
IMIA1 (compare match/ inputcapture A1)	16-bit timer channel 1	28	H'0070 to H'0073	IPRA1	
IMIB1 (compare match/ input capture B1)		29	H'0074 to H'0077		
OVI1 (overflow 1)		30	H'0078 to H'007B		
Reserved	—	31	H'007C to H'007F		Low

Interrupt Source	Origin	Vector Number	Vector Address*		Priority
			Advanced Mode	IPR	
IMIA2 (compare match/ input capture A2)	16-bit timer channel 2	32	H'0080 to H'0083	IPRA0	High ↑
IMIB2 (compare match/ input capture B2)		33	H'0084 to H'0087		
OVI2 (overflow 2)		34	H'0088 to H'008B		
Reserved	—	35	H'008C to H'008F		
CMIA0 (compare match A0)	8-bit timer channel 0/1	36	H'0090 to H'0093	IPRB7	
CMIB0 (compare match B0)		37	H'0094 to H'0097		
CMIA1/CMIB1 (compare match A1/B1)		38	H'0098 to H'009B		
TOVI0/TOVI1 (overflow 0/1)		39	H'009C to H'009F		
CMIA2 (compare match A2)	8-bit timer channel 2/3	40	H'00A0 to H'00A3	IPRB6	
CMIB2 (compare match B2)		41	H'00A4 to H'00A7		
CMIA3/CMIB3 (compare match A3/B3)		42	H'00A8 to H'00AB		
TOVI2/TOVI3 (overflow 2/3)		43	H'00AC to H'00AF		
DEND0A	DMAC	44	H'00B0 to H'00B3	IPRB5	
DEND0B		45	H'00B4 to H'00B7		
DEND1A		46	H'00B8 to H'00BB		
DEND1B		47	H'00BC to H'00BF		
Reserved	—	48	H'00C0 to H'00C3	—	
		49	H'00C4 to H'00C7		
		50	H'00C8 to H'00CB		
		51	H'00CC to H'00CF		
					Low

Interrupt Source	Origin	Vector Number	Vector Address*		Priority
			Advanced Mode	IPR	
ERI0 (receive error 0)	SCI channel 0	52	H'00D0 to H'00D3	IPRB3	High ↑
RXI0 (receive data full 0)		53	H'00D4 to H'00D7		
TXI0 (transmit data empty 0)		54	H'00D8 to H'00DB		
TEI0 (transmit end 0)		55	H'00DC to H'00DF		
ERI1 (receive error 1)	SCI channel 1	56	H'00E0 to H'00E3	IPRB2	
RXI1 (receive data full 1)		57	H'00E4 to H'00E7		
TXI1 (transmit data empty 1)		58	H'00E8 to H'00EB		
TEI1 (transmit end 1)		59	H'00EC to H'00EF		
ERI2 (receive error 2)	SCI channel 2	60	H'00F0 to H'00F3	IPRB1	Low ↓
RXI2 (receive data full 2)		61	H'00F4 to H'00F7		
TXI2 (transmit data empty 2)		62	H'00F8 to H'00FB		
TEI2 (transmit end 2)		63	H'00FC to H'00FF		

Note: * Lower 16 bits of the address.

5.4 Interrupt Operation

5.4.1 Interrupt Handling Process

The H8/3006 and H8/3007 handles interrupts differently depending on the setting of the UE bit. When UE = 1, interrupts are controlled by the I bit. When UE = 0, interrupts are controlled by the I and UI bits. Table 5-4 indicates how interrupts are handled for all setting combinations of the UE, I, and UI bits.

NMI interrupts are always accepted except in the reset and hardware standby states. IRQ interrupts and interrupts from the on-chip supporting modules have their own enable bits. Interrupt requests are ignored when the enable bits are cleared to 0.

Table 5-4 UE, I, and UI Bit Settings and Interrupt Handling

SYSCR	CCR		Description
	I	UI	
1	0	—	All interrupts are accepted. Interrupts with priority level 1 have higher priority.
	1	—	No interrupts are accepted except NMI.
0	0	—	All interrupts are accepted. Interrupts with priority level 1 have higher priority.
	1	0	NMI and interrupts with priority level 1 are accepted.
		1	No interrupts are accepted except NMI.

UE = 1: Interrupts IRQ₀ to IRQ₅ and interrupts from the on-chip supporting modules can all be masked by the I bit in the CPU's CCR. Interrupts are masked when the I bit is set to 1, and unmasked when the I bit is cleared to 0. Interrupts with priority level 1 have higher priority. Figure 5-4 is a flowchart showing how interrupts are accepted when UE = 1.

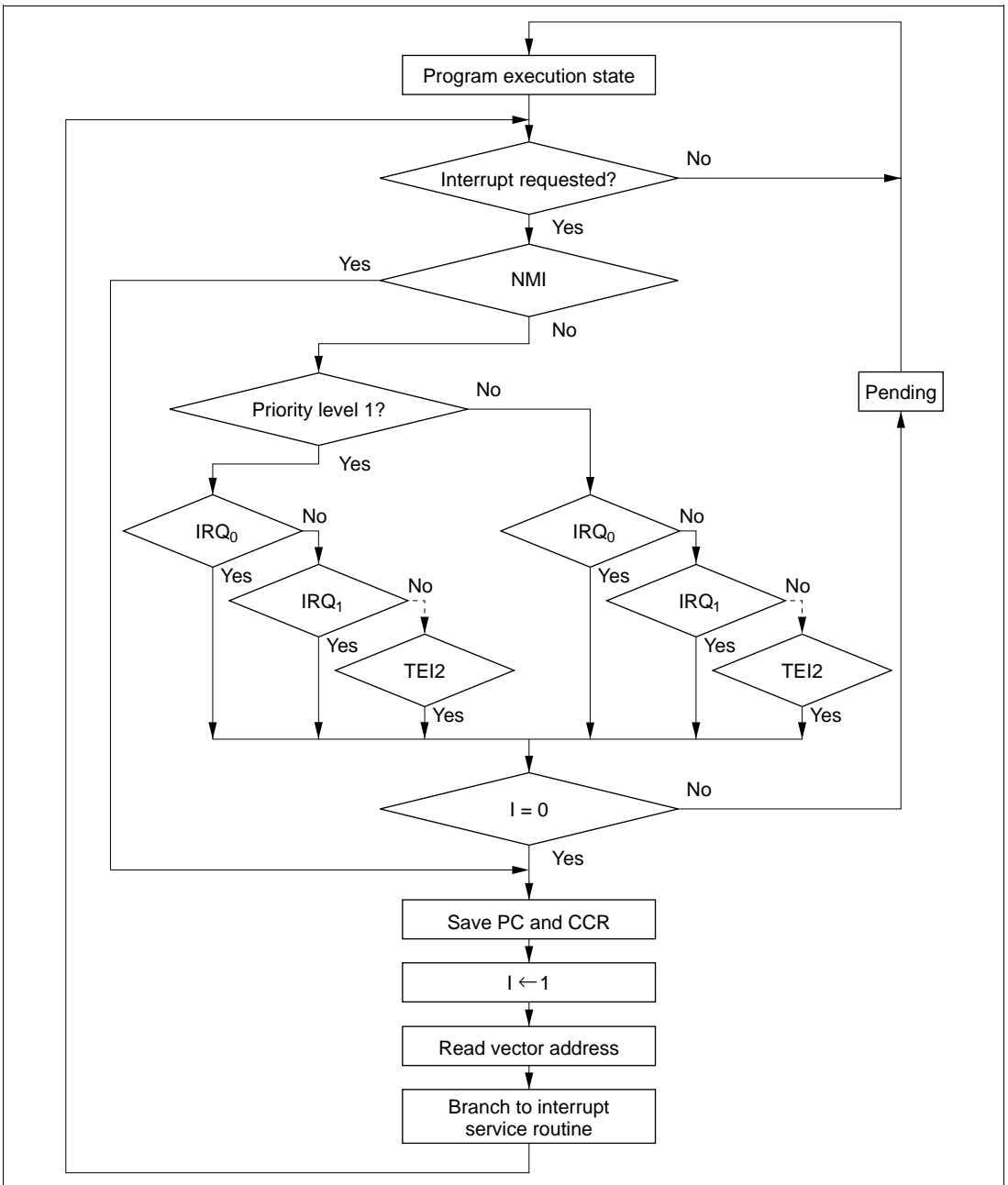

Figure 5-4 Process Up to Interrupt Acceptance when UE = 1

- If an interrupt condition occurs and the corresponding interrupt enable bit is set to 1, an interrupt request is sent to the interrupt controller.
- When the interrupt controller receives one or more interrupt requests, it selects the highest-

priority request, following the IPR interrupt priority settings, and holds other requests pending. If two or more interrupts with the same IPR setting are requested simultaneously, the interrupt controller follows the priority order shown in table 5-3.

- The interrupt controller checks the I bit. If the I bit is cleared to 0, the selected interrupt request is accepted. If the I bit is set to 1, only NMI is accepted; other interrupt requests are held pending.
- When an interrupt request is accepted, interrupt exception handling starts after execution of the current instruction has been completed.
- In interrupt exception handling, PC and CCR are saved to the stack area. The PC value that is saved indicates the address of the first instruction that will be executed after the return from the interrupt service routine.
- Next the I bit is set to 1 in CCR, masking all interrupts except NMI.
- The vector address of the accepted interrupt is generated, and the interrupt service routine starts executing from the address indicated by the contents of the vector address.

UE = 0: The I and UI bits in the CPU's CCR and the IPR bits enable three-level masking of IRQ_0 to IRQ_3 interrupts and interrupts from the on-chip supporting modules.

- Interrupt requests with priority level 0 are masked when the I bit is set to 1, and are unmasked when the I bit is cleared to 0.
- Interrupt requests with priority level 1 are masked when the I and UI bits are both set to 1, and are unmasked when either the I bit or the UI bit is cleared to 0.

For example, if the interrupt enable bits of all interrupt requests are set to 1, IPRA is set to H'20, and IPRB is set to H'00 (giving IRQ_2 and IRQ_3 interrupt requests priority over other interrupts), interrupts are masked as follows:

- a. If $I = 0$, all interrupts are unmasked (priority order: $NMI > IRQ_2 > IRQ_3 > IRQ_0 \dots$).
- b. If $I = 1$ and $UI = 0$, only NMI, IRQ_2 , and IRQ_3 are unmasked.
- c. If $I = 1$ and $UI = 1$, all interrupts are masked except NMI.

Figure 5-5 shows the transitions among the above states.

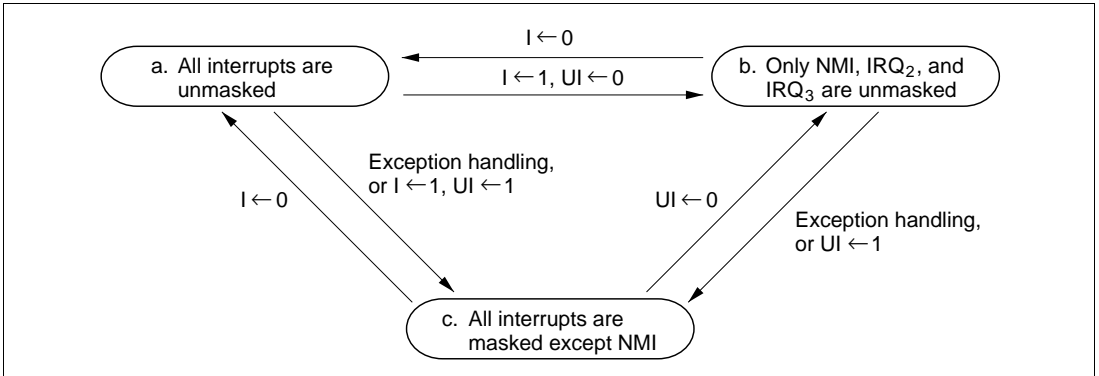

Figure 5-5 Interrupt Masking State Transitions (Example)

Figure 5-6 is a flowchart showing how interrupts are accepted when UE = 0.

- If an interrupt condition occurs and the corresponding interrupt enable bit is set to 1, an interrupt request is sent to the interrupt controller.
- When the interrupt controller receives one or more interrupt requests, it selects the highest-priority request, following the IPR interrupt priority settings, and holds other requests pending. If two or more interrupts with the same IPR setting are requested simultaneously, the interrupt controller follows the priority order shown in table 5-3.
- The interrupt controller checks the I bit. If the I bit is cleared to 0, the selected interrupt request is accepted regardless of its IPR setting, and regardless of the UI bit. If the I bit is set to 1 and the UI bit is cleared to 0, only NMI and interrupts with priority level 1 are accepted; interrupt requests with priority level 0 are held pending. If the I bit and UI bit are both set to 1, interrupt requests are held pending.
- When an interrupt request is accepted, interrupt exception handling starts after execution of the current instruction has been completed.
- In interrupt exception handling, PC and CCR are saved to the stack area. The PC value that is saved indicates the address of the first instruction that will be executed after the return from the interrupt service routine.
- The I and UI bits are set to 1 in CCR, masking all interrupts except NMI.
- The vector address of the accepted interrupt is generated, and the interrupt service routine starts executing from the address indicated by the contents of the vector address.

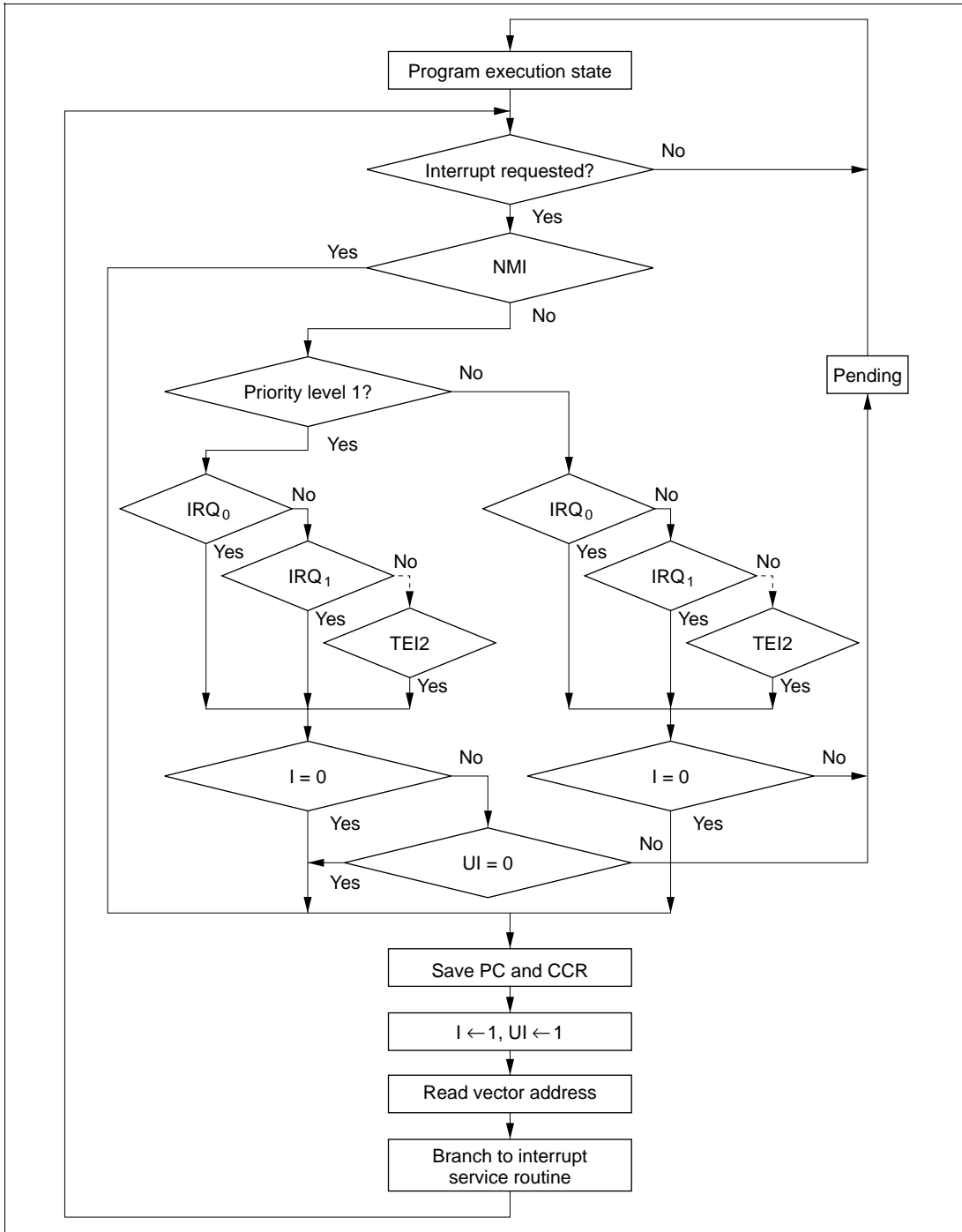

Figure 5-6 Process Up to Interrupt Acceptance when UE = 0

5.4.2 Interrupt Sequence

Figure 5-7 shows the interrupt sequence in mode 2 when the program code and stack are in an external memory area accessed in two states via a 16-bit bus.

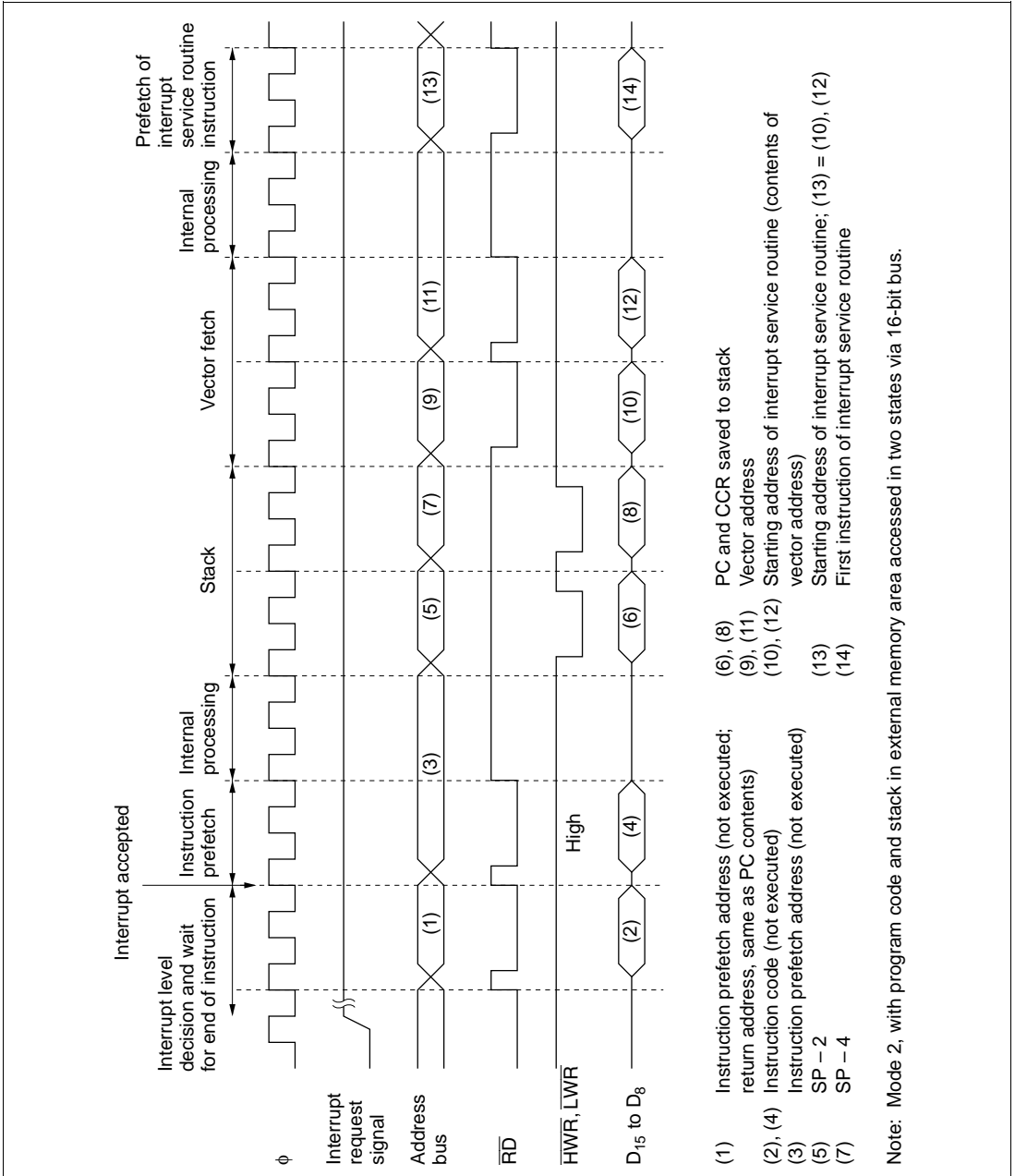

Figure 5-7 Interrupt Sequence

5.4.3 Interrupt Response Time

Table 5-5 indicates the interrupt response time from the occurrence of an interrupt request until the first instruction of the interrupt service routine is executed.

Table 5-5 Interrupt Response Time

No.	Item	On-Chip Memory	External Memory			
			8-Bit Bus		16-Bit Bus	
			2 States	3 States	2 States	3 States
1	Interrupt priority decision	2 ^{*1}	2 ^{*1}	2 ^{*1}	2 ^{*1}	2 ^{*1}
2	Maximum number of states until end of current instruction	1 to 23	1 to 27	1 to 31 ^{*4}	1 to 23	1 to 25 ^{*4}
3	Saving PC and CCR to stack	4	8	12 ^{*4}	4	6 ^{*4}
4	Vector fetch	4	8	12 ^{*4}	4	6 ^{*4}
5	Instruction prefetch ^{*2}	4	8	12 ^{*4}	4	6 ^{*4}
6	Internal processing ^{*3}	4	4	4	4	4
Total		19 to 41	31 to 57	43 to 73	19 to 41	25 to 49

- Notes:
1. 1 state for internal interrupts.
 2. Prefetch after the interrupt is accepted and prefetch of the first instruction in the interrupt service routine.
 3. Internal processing after the interrupt is accepted and internal processing after vector fetch.
 4. The number of states increases if wait states are inserted in external memory access.

5.5 Usage Notes

5.5.1 Contention between Interrupt and Interrupt-Disabling Instruction

When an instruction clears an interrupt enable bit to 0 to disable the interrupt, the interrupt is not disabled until after execution of the instruction is completed. If an interrupt occurs while a BCLR, MOV, or other instruction is being executed to clear its interrupt enable bit to 0, at the instant when execution of the instruction ends the interrupt is still enabled, so its interrupt exception handling is carried out. If a higher-priority interrupt is also requested, however, interrupt exception handling for the higher-priority interrupt is carried out, and the lower-priority interrupt is ignored. This also applies to the clearing of an interrupt flag to 0.

Figure 5-8 shows an example in which an IMIEA bit is cleared to 0 in the 16-bit timer's TISRA register.

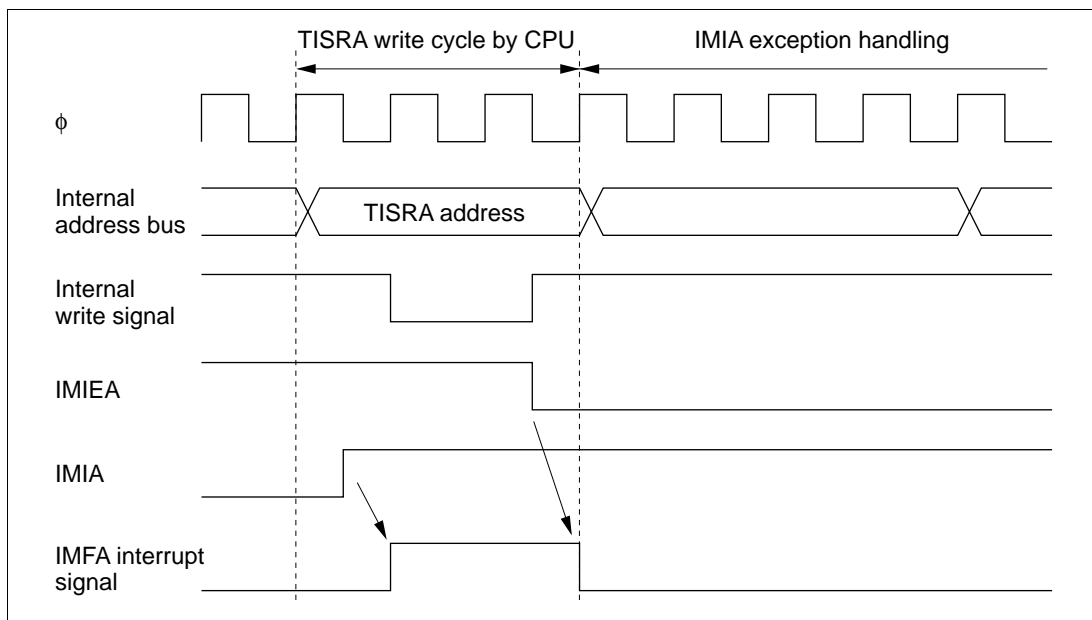

Figure 5-8 Contention between Interrupt and Interrupt-Disabling Instruction

This type of contention will not occur if the interrupt is masked when the interrupt enable bit or flag is cleared to 0.

5.5.2 Instructions that Inhibit Interrupts

The LDC, ANDC, ORC, and XORC instructions inhibit interrupts. When an interrupt occurs, after determining the interrupt priority, the interrupt controller requests a CPU interrupt. If the CPU is currently executing one of these interrupt-inhibiting instructions, however, when the instruction is completed the CPU always continues by executing the next instruction.

5.5.3 Interrupts during EEPMOV Instruction Execution

The EEPMOV.B and EEPMOV.W instructions differ in their reaction to interrupt requests.

When the EEPMOV.B instruction is executing a transfer, no interrupts are accepted until the transfer is completed, not even NMI.

When the EEPMOV.W instruction is executing a transfer, interrupt requests other than NMI are not accepted until the transfer is completed. If NMI is requested, NMI exception handling starts at a transfer cycle boundary. The PC value saved on the stack is the address of the next instruction. Programs should be coded as follows to allow for NMI interrupts during EEPMOV.W execution:

```
L1 : EEPMOV.W  
    MOV.W R4, R4  
    BNE L1
```

Section 6 Bus Controller

6.1 Overview

The H8/3006 and H8/3007 have an on-chip bus controller (BSC) that manages the external address space divided into eight areas. The bus specifications, such as bus width and number of access states, can be set independently for each area, enabling multiple memories to be connected easily.

The bus controller also has a bus arbitration function that controls the operation of the internal bus masters—the CPU, DMA controller (DMAC), and DRAM interface and can release the bus to an external device.

6.1.1 Features

The features of the bus controller are listed below.

- Manages external address space in area units
 - Manages the external space as eight areas (0 to 7) of 128 kbytes in 1M-byte modes, or 2 Mbytes in 16-Mbyte modes
 - Bus specifications can be set independently for each area
 - DRAM/burst ROM interfaces can be set
- Basic bus interface
 - Chip select (\overline{CS}_0 to \overline{CS}_7) can be output for areas 0 to 7
 - 8-bit access or 16-bit access can be selected for each area
 - Two-state access or three-state access can be selected for each area
 - Program wait states can be inserted for each area
 - Pin wait insertion capability is provided
- DRAM interface
 - DRAM interface can be set for areas 2 to 5
 - Row address/column address multiplexed output (8/9/10 bits)
 - 2-CAS byte access mode
 - Burst operation (fast page mode)
 - T_p cycle insertion to secure RAS precharging time
 - Choice of CAS-before-RAS refreshing or self-refreshing
- Burst ROM interface
 - Burst ROM interface can be set for area 0
 - Selection of two- or three-state burst access

- Idle cycle insertion
 - An idle cycle can be inserted in case of an external read cycle between different areas
 - An idle cycle can be inserted when an external read cycle is immediately followed by an external write cycle
- Bus arbitration function
 - A built-in bus arbiter grants the bus right to the CPU, DMAC, DRAM interface, or an external bus master
- Other features
 - The refresh counter (refresh timer) can be used as an interval timer

6.1.2 Block Diagram

Figure 6.1 shows a block diagram of the bus controller.

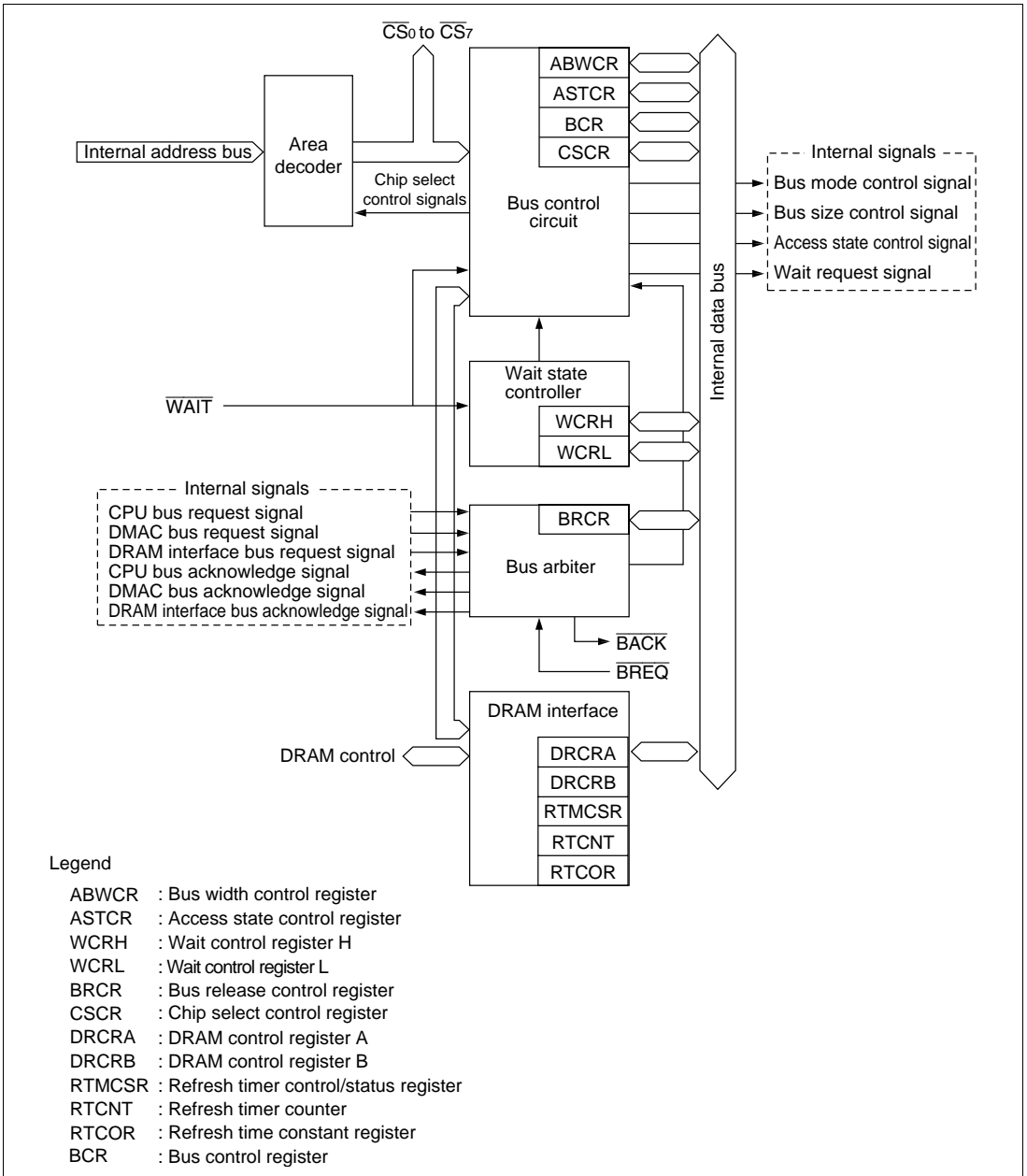

Figure 6.1 Block Diagram of Bus Controller

6.1.3 Pin Configuration

Table 6.1 summarizes the input/output pins of the bus controller.

Table 6.1 Bus Controller Pins

Name	Abbreviation	I/O	Function
Chip select 0 to 7	\overline{CS}_0 to \overline{CS}_7	Output	Strobe signals selecting areas 0 to 7
Address strobe	\overline{AS}	Output	Strobe signal indicating valid address output on the address bus
Read	\overline{RD}	Output	Strobe signal indicating reading from the external address space
High write	\overline{HWR}	Output	Strobe signal indicating writing to the external address space, with valid data on the upper data bus (D_{15} to D_8)
Low write	\overline{LWR}	Output	Strobe signal indicating writing to the external address space, with valid data on the lower data bus (D_7 to D_0)
Wait	\overline{WAIT}	Input	Wait request signal for access to external three-state access areas
Bus request	\overline{BREQ}	Input	Request signal for releasing the bus to an external device
Bus acknowledge	\overline{BACK}	Output	Acknowledge signal indicating release of the bus to an external device

6.1.4 Register Configuration

Table 6.2 summarizes the bus controller's registers.

Table 6.2 Bus Controller Registers

Address* ¹	Name	Abbreviation	R/W	Initial Value
H'EE020	Bus width control register	ABWCR	R/W	H'FF* ²
H'EE021	Access state control register	ASTCR	R/W	H'FF
H'EE022	Wait control register H	WCRH	R/W	H'FF
H'EE023	Wait control register L	WCRL	R/W	H'FF
H'EE013	Bus release control register	BRCR	R/W	H'FE* ³
H'EE01F	Chip select control register	CSCR	R/W	H'0F
H'EE024	Bus control register	BCR	R/W	H'C6
H'EE026	DRAM control register A	DRCRA	R/W	H'10
H'EE027	DRAM control register B	DRCRB	R/W	H'08
H'EE028	Refresh timer control/status register	RTMCSR	R(W)* ⁴	H'07
H'EE029	Refresh timer counter	RTCNT	R/W	H'00
H'EE02A	Refresh time constant register	RTCOR	R/W	H'FF

- Notes:
1. Lower 20 bits of the address in advanced mode.
 2. In modes 2 and 4, the initial value is H'00.
 3. In modes 3 and 4, the initial value is H'EE.
 4. For Bit 7, only 0 can be written to clear the flag.

6.2 Register Descriptions

6.2.1 Bus Width Control Register (ABWCR)

ABWCR is an 8-bit readable/writable register that selects 8-bit or 16-bit access for each area.

Bit	7	6	5	4	3	2	1	0
	ABW7	ABW6	ABW5	ABW4	ABW3	ABW2	ABW1	ABW0
Modes 1 and 3	Initial value	1	1	1	1	1	1	1
	Read/Write	R/W	R/W	R/W	R/W	R/W	R/W	R/W
Modes 2 and 4	Initial value	0	0	0	0	0	0	0
	Read/Write	R/W	R/W	R/W	R/W	R/W	R/W	R/W

When ABWCR contains H'FF (selecting 8-bit access for all areas), the chip operates in 8-bit bus mode: the upper data bus (D_{15} to D_8) is valid, and port 4 is an input/output port. When at least one bit is cleared to 0 in ABWCR, the chip operates in 16-bit bus mode with a 16-bit data bus (D_{15} to D_0). In modes 1 and 3, ABWCR is initialized to H'FF by a reset and in hardware standby mode. In modes 2 and 4, ABWCR is initialized to H'00 by a reset and in hardware standby mode. It is not initialized in software standby mode.

Bits 7 to 0—Area 7 to 0 Bus Width Control (ABW7 to ABW0): These bits select 8-bit access or 16-bit access for the corresponding areas.

Bits 7 to 0

ABW7 to ABW0 Description

0	Areas 7 to 0 are 16-bit access areas
1	Areas 7 to 0 are 8-bit access areas

ABWCR specifies the data bus width of external memory areas. The data bus width of on-chip memory and registers is fixed, and does not depend on ABWCR settings.

6.2.2 Access State Control Register (ASTCR)

ASTCR is an 8-bit readable/writable register that selects whether each area is accessed in two states or three states.

Bit	7	6	5	4	3	2	1	0
	AST7	AST6	AST5	AST4	AST3	AST2	AST1	AST0
Initial value	1	1	1	1	1	1	1	1
Read/Write	R/W	R/W	R/W	R/W	R/W	R/W	R/W	R/W

Bits selecting number of states for access to each area

ASTCR is initialized to H'FF by a reset and in hardware standby mode. It is not initialized in software standby mode.

Bits 7 to 0—Area 7 to 0 Access State Control (AST7 to AST0): These bits select whether the corresponding area is accessed in two or three states.

Bits 7 to 0

AST7 to AST0	Description
0	Areas 7 to 0 are accessed in two states
1	Areas 7 to 0 are accessed in three states (Initial value)

ASTCR specifies the number of states in which external areas are accessed. On-chip memory and registers are accessed in a fixed number of states that does not depend on ASTCR settings.

When the corresponding area is designated as DRAM space by bits DRAS2 to DRAS0 in DRAM control register A (DRCRA), the number of access states does not depend on the AST bit setting. When an AST bit is cleared to 0, programmable wait insertion is not performed.

6.2.3 Wait Control Registers H and L (WCRH, WCRL)

WCRH and WCRL are 8-bit readable/writable registers that select the number of program wait states for each area.

On-chip memory and registers are accessed in a fixed number of states that does not depend on WCRH/WCRL settings.

WCRH and WCRL are initialized to H'FF by a reset and in hardware standby mode. They are not initialized in software standby mode.

WCRH

Bit	7	6	5	4	3	2	1	0
	W71	W70	W61	W60	W51	W50	W41	W40
Initial value	1	1	1	1	1	1	1	1
Read/Write	R/W	R/W	R/W	R/W	R/W	R/W	R/W	R/W

Bits 7 and 6—Area 7 Wait Control 1 and 0 (W71, W70): These bits select the number of program wait states when area 7 in external space is accessed while the AST7 bit in ASTCR is set to 1.

Bit 7 W71	Bit 6 W70	Description
0	0	Program wait not inserted when external space area 7 is accessed
	1	1 program wait state inserted when external space area 7 is accessed
1	0	2 program wait states inserted when external space area 7 is accessed
	1	3 program wait states inserted when external space area 7 is accessed (Initial value)

Bits 5 and 4—Area 6 Wait Control 1 and 0 (W61, W60): These bits select the number of program wait states when area 6 in external space is accessed while the AST6 bit in ASTCR is set to 1.

Bit 5 W61	Bit 4 W60	Description
0	0	Program wait not inserted when external space area 6 is accessed
	1	1 program wait state inserted when external space area 6 is accessed
1	0	2 program wait states inserted when external space area 6 is accessed
	1	3 program wait states inserted when external space area 6 is accessed (Initial value)

Bits 3 and 2—Area 5 Wait Control 1 and 0 (W51, W50): These bits select the number of program wait states when area 5 in external space is accessed while the AST5 bit in ASTCR is set to 1.

Bit 3 W51	Bit 2 W50	Description
0	0	Program wait not inserted when external space area 5 is accessed
	1	1 program wait state inserted when external space area 5 is accessed
1	0	2 program wait states inserted when external space area 5 is accessed
	1	3 program wait states inserted when external space area 5 is accessed (Initial value)

Bits 1 and 0—Area 4 Wait Control 1 and 0 (W41, W40): These bits select the number of program wait states when area 4 in external space is accessed while the AST4 bit in ASTCR is set to 1.

Bit 1 W41	Bit 0 W40	Description
0	0	Program wait not inserted when external space area 4 is accessed
	1	1 program wait state inserted when external space area 4 is accessed
1	0	2 program wait states inserted when external space area 4 is accessed
	1	3 program wait states inserted when external space area 4 is accessed (Initial value)

WCRL

Bit	7	6	5	4	3	2	1	0
	W31	W30	W21	W20	W11	W10	W01	W00
Initial value	1	1	1	1	1	1	1	1
Read/Write	R/W	R/W	R/W	R/W	R/W	R/W	R/W	R/W

Bits 7 and 6—Area 3 Wait Control 1 and 0 (W31, W30): These bits select the number of program wait states when area 3 in external space is accessed while the AST3 bit in ASTCR is set to 1.

Bit 7 W31	Bit 6 W30	Description
0	0	Program wait not inserted when external space area 3 is accessed
	1	1 program wait state inserted when external space area 3 is accessed
1	0	2 program wait states inserted when external space area 3 is accessed
	1	3 program wait states inserted when external space area 3 is accessed (Initial value)

Bits 5 and 4—Area 2 Wait Control 1 and 0 (W21, W20): These bits select the number of program wait states when area 2 in external space is accessed while the AST2 bit in ASTCR is set to 1.

Bit 5 W21	Bit 4 W20	Description
0	0	Program wait not inserted when external space area 2 is accessed
	1	1 program wait state inserted when external space area 2 is accessed
1	0	2 program wait states inserted when external space area 2 is accessed
	1	3 program wait states inserted when external space area 2 is accessed (Initial value)

Bits 3 and 2—Area 1 Wait Control 1 and 0 (W11, W10): These bits select the number of program wait states when area 1 in external space is accessed while the AST1 bit in ASTCR is set to 1.

Bit 3 W11	Bit 2 W10	Description
0	0	Program wait not inserted when external space area 1 is accessed
	1	1 program wait state inserted when external space area 1 is accessed
1	0	2 program wait states inserted when external space area 1 is accessed
	1	3 program wait states inserted when external space area 1 is accessed (Initial value)

Bits 1 and 0—Area 0 Wait Control 1 and 0 (W01, W00): These bits select the number of program wait states when area 0 in external space is accessed while the AST0 bit in ASTCR is set to 1.

Bit 1 W01	Bit 0 W00	Description
0	0	Program wait not inserted when external space area 0 is accessed
	1	1 program wait state inserted when external space area 0 is accessed
1	0	2 program wait states inserted when external space area 0 is accessed
	1	3 program wait states inserted when external space area 0 is accessed (Initial value)

6.2.4 Bus Release Control Register (BRCR)

BRCR is an 8-bit readable/writable register that enables address output on bus lines A_{23} to A_{20} and enables or disables release of the bus to an external device.

Bit	7	6	5	4	3	2	1	0
	A23E	A22E	A21E	A20E	—	—	—	BRLE
Modes 1 and 2	Initial value	1	1	1	1	1	1	0
	Read/Write	—	—	—	—	—	—	R/W
Modes 3 and 4	Initial value	1	1	0	1	1	1	0
	Read/Write	R/W	R/W	R/W	—	—	—	R/W

Address 23 to 20 enable
These bits enable PA_7 to PA_4 to be used for A_{23} to A_{20} address output

Bus release enable
Enables or disables release of the bus to an external device

BRCR is initialized to H'FE in modes 1 and 2, and to H'EE in modes 3 and 4, by a reset and in hardware standby mode. It is not initialized in software standby mode.

Bit 7—Address 23 Enable (A23E): Enables PA_4 to be used as the A_{23} address output pin. Writing 0 in this bit enables A_{23} output from PA_4 . In modes 1 and 2, this bit cannot be modified and PA_4 has its ordinary port functions.

Bit 7

A23E	Description
0	PA_4 is the A_{23} address output pin
1	PA_4 is an input/output pin (Initial value)

Bit 6—Address 22 Enable (A22E): Enables PA_5 to be used as the A_{22} address output pin. Writing 0 in this bit enables A_{22} output from PA_5 . In modes 1 and 2, this bit cannot be modified and PA_5 has its ordinary port functions.

Bit 6

A22E	Description
0	PA_5 is the A_{22} address output pin
1	PA_5 is an input/output pin (Initial value)

Bit 5—Address 21 Enable (A21E): Enables PA₆ to be used as the A₂₁ address output pin. Writing 0 in this bit enables A₂₁ output from PA₆. In modes 1 and 2, this bit cannot be modified and PA₆ has its ordinary port functions.

Bit 5 A21E	Description
0	PA ₆ is the A ₂₁ address output pin
1	PA ₆ is an input/output pin (Initial value)

Bit 4—Address 20 Enable (A20E): Initial value of this bit varies depending on the mode. This bit can not be modified.

Bit 4 A20E	Description
0	PA ₇ is the A ₂₀ address output pin (Initial value in mode 3 or 4)
1	PA ₇ is an input/output pin (Initial value in mode 1 or 2)

Bits 3 to 1—Reserved: These bits cannot be modified and are always read as 1.

Bit 0—Bus Release Enable (BRLE): Enables or disables release of the bus to an external device.

Bit 0 BRLE	Description
0	The bus cannot be released to an external device $\overline{\text{BREQ}}$ and $\overline{\text{BACK}}$ can be used as input/output pins (Initial value)
1	The bus can be released to an external device

6.2.5 Bus Control Register (BCR)

Bit	7	6	5	4	3	2	1	0
	ICIS1	ICIS0	BROME	BRSTS1	BRSTS0	—	RDEA	WAITE
Initial value	1	1	0	0	0	1	1	0
Read/Write	R/W	R/W	R/W	R/W	R/W	—	R/W	R/W

BCR is an 8-bit readable/writable register that enables or disables idle cycle insertion, selects the area division unit, and enables or disables $\overline{\text{WAIT}}$ pin input.

BCR is initialized to H'C6 by a reset and in hardware standby mode. It is not initialized in software standby mode.

Bit 7—Idle Cycle Insertion 1 (ICIS1): Selects whether one idle cycle state is to be inserted between bus cycles in case of consecutive external read cycles for different areas.

Bit 7

ICIS1	Description
0	No idle cycle inserted in case of consecutive external read cycles for different areas
1	Idle cycle inserted in case of consecutive external read cycles for different areas (Initial value)

Bit 6—Idle Cycle Insertion 0 (ICIS0): Selects whether one idle cycle state is to be inserted between bus cycles in case of consecutive external read and write cycles.

Bit 6

ICIS0	Description
0	No idle cycle inserted in case of consecutive external read and write cycles
1	Idle cycle inserted in case of consecutive external read and write cycles (Initial value)

Bit 5—Burst ROM Enable (BROME): Selects whether area 0 is a burst ROM interface area.

Bit 5

BROME	Description
0	Area 0 is a basic bus interface area (Initial value)
1	Area 0 is a burst ROM interface area

Bit 4—Burst Cycle Select 1 (BRSTS1): Selects the number of burst cycle states for the burst ROM interface.

Bit 4

BRSTS1	Description
0	Burst access cycle comprises 2 states (Initial value)
1	Burst access cycle comprises 3 states

Bit 3—Burst Cycle Select 0 (BRSTS0): Selects the number of words that can be accessed in a burst ROM interface burst access.

Bit 3 BRSTS0	Description
0	Max. 4 words in burst access (burst access on match of address bits above A3) (Initial value)
1	Max. 8 words in burst access (burst access on match of address bits above A4)

Bit 2—Reserved: Read-only bit, always read as 1.

Bit 1—Area Division Unit Select (RDEA): Selects the memory map area division units. This bit is valid in modes 3 and 4, and is invalid in modes 1 and 2.

Bit 1 RDEA	Description								
0	Area divisions are as follows: <table style="width: 100%; border: none;"> <tr> <td style="width: 33%;">Area 0: 2 Mbytes</td> <td style="width: 33%;">Area 4: 1.93 Mbytes</td> </tr> <tr> <td>Area 1: 2 Mbytes</td> <td>Area 5: 4 kbytes</td> </tr> <tr> <td>Area 2: 8 Mbytes</td> <td>Area 6: 23.75 kbytes</td> </tr> <tr> <td>Area 3: 2 Mbytes</td> <td>Area 7: 22 bytes</td> </tr> </table>	Area 0: 2 Mbytes	Area 4: 1.93 Mbytes	Area 1: 2 Mbytes	Area 5: 4 kbytes	Area 2: 8 Mbytes	Area 6: 23.75 kbytes	Area 3: 2 Mbytes	Area 7: 22 bytes
Area 0: 2 Mbytes	Area 4: 1.93 Mbytes								
Area 1: 2 Mbytes	Area 5: 4 kbytes								
Area 2: 8 Mbytes	Area 6: 23.75 kbytes								
Area 3: 2 Mbytes	Area 7: 22 bytes								
1	Areas 0 to 7 are the same size (2 Mbytes) (Initial value)								

Bit 0—WAIT Pin Enable (WAITE): Enables or disables wait insertion by means of the $\overline{\text{WAIT}}$ pin.

Bit 0 WAITE	Description
0	$\overline{\text{WAIT}}$ pin wait input is disabled, and the $\overline{\text{WAIT}}$ pin can be used as an input/output port (Initial value)
1	$\overline{\text{WAIT}}$ pin wait input is enabled

6.2.6 Chip Select Control Register (CSCR)

CSCR is an 8-bit readable/writable register that enables or disables output of chip select signals ($\overline{\text{CS}}_7$ to $\overline{\text{CS}}_4$).

If output of a chip select signal is enabled by a setting in this register, the corresponding pin functions a chip select signal ($\overline{\text{CS}}_7$ to $\overline{\text{CS}}_4$) output regardless of any other settings.

Bit	7	6	5	4	3	2	1	0
	CS7E	CS6E	CS5E	CS4E	—	—	—	—
Initial value	0	0	0	0	1	1	1	1
Read/Write	R/W	R/W	R/W	R/W	—	—	—	—

Chip select 7 to 4 enable
 These bits enable or disable
 chip select signal output

Reserved bits

CSCR is initialized to H'0F by a reset and in hardware standby mode. It is not initialized in software standby mode.

Bits 7 to 4—Chip Select 7 to 4 Enable (CS7E to CS4E): These bits enable or disable output of the corresponding chip select signal.

Bit n CSnE	Description
0	Output of chip select signal CSn is disabled (Initial value)
1	Output of chip select signal CSn is enabled

Note: n = 7 to 4

Bits 3 to 0—Reserved: These bits cannot be modified and are always read as 1.

6.2.7 DRAM Control Register A (DRCRA)

Bit	7	6	5	4	3	2	1	0
	DRAS2	DRAS1	DRAS0	—	BE	RDM	SRFMD	RFSHE
Initial value	0	0	0	1	0	0	0	0
Read/Write	R/W	R/W	R/W	—	R/W	R/W	R/W	R/W

DRCRA is an 8-bit readable/writable register that selects the areas that have a DRAM interface function, and the access mode, and enables or disables self-refreshing and refresh pin output.

DRCRA is initialized to H'10 by a reset and in hardware standby mode. It is not initialized in software standby mode.

Bits 7 to 5—DRAM Area Select (DRAS2 to DRAS0): These bits select which of areas 2 to 5 are to function as DRAM interface areas (DRAM space), and at the same time select the $\overline{\text{RAS}}$ output pin corresponding to each DRAM space.

			Description			
Bit 7 DRAS2	Bit 6 DRAS1	Bit 5 DRAS0	Area 5	Area 4	Area 3	Area 2
0	0	0	Normal	Normal	Normal	Normal
		1	Normal	Normal	Normal	DRAM space (\overline{CS}_2)
	1	0	Normal	Normal	DRAM space (\overline{CS}_3)	DRAM space (\overline{CS}_2)
1	0	0	Normal	DRAM space (\overline{CS}_4)	DRAM space (\overline{CS}_3)	DRAM space (\overline{CS}_2)
		1	DRAM space (\overline{CS}_5)	DRAM space (\overline{CS}_4)	DRAM space (\overline{CS}_3)	DRAM space (\overline{CS}_2)
	1	0	DRAM space (\overline{CS}_4)*		DRAM space (\overline{CS}_2)*	
		1	DRAM space (\overline{CS}_2)*			

Note: * A single \overline{CS}_n pin serves as a common \overline{RAS} output pin for a number of areas. Unused \overline{CS}_n pins can be used as input/output ports.

When any of bits DRAS2 to DRAS0 is set to 1, it is not possible to write to DRCRB, RTMCSR, RTCNT, or RTCOR. However, 0 can be written to the CMF flag in RTMCSR to clear the flag.

When an arbitrary value has been set in DRAS2 to DRAS0, a write of a different value other than 000 must not be performed.

Bit 4—Reserved: This bit cannot be modified and is always read as 1.

Bit 3—Burst Access Enable (BE): Enables or disables burst access to DRAM space. DRAM space burst access is performed in fast page mode.

Bit 3 BE	Description
0	Burst disabled (always full access) (Initial value)
1	DRAM space access performed in fast page mode

Bit 2—RAS Down Mode (RDM): Selects whether to wait for the next DRAM access with the \overline{RAS} signal held low (RAS down mode), or to drive the RAS signal high again (RAS up mode), when burst access is enabled for DRAM space (BE = 1), and access to DRAM is interrupted.

Caution is required when the \overline{HWR} and \overline{LWR} are used as the \overline{UCAS} and \overline{LCAS} output pins. For details, see RAS Down Mode and RAS Up Mode in section 6.5.10, Burst Operation.

Bit 2 RDM	Description
0	DRAM interface: RAS up mode selected (Initial value)
1	DRAM interface: RAS down mode selected

Bit 1—Self-Refresh Mode (SRFMD): Specifies DRAM self-refreshing in software standby mode.

When any of areas 2 to 5 is designated as DRAM space, DRAM self-refreshing is possible when a transition is made to software standby mode after the SRFMD bit has been set to 1.

The normal access state is restored when software standby mode is exited, regardless of the SRFMD setting.

Bit 1 SRFMD	Description
0	DRAM self-refreshing disabled in software standby mode (Initial value)
1	DRAM self-refreshing enabled in software standby mode

Bit 0—Refresh Pin Enable (RFSHE): Enables or disables $\overline{\text{RFSH}}$ pin refresh signal output. If areas 2 to 5 are not designated as DRAM space, this bit should not be set to 1.

Bit 0 RFSHE	Description
0	$\overline{\text{RFSH}}$ pin refresh signal output disabled (Initial value) ($\overline{\text{RFSH}}$ pin can be used as input/output port)
1	$\overline{\text{RFSH}}$ pin refresh signal output enabled

6.2.8 DRAM Control Register B (DRCRB)

Bit	7	6	5	4	3	2	1	0
	MXC1	MXC0	CSEL	RCYCE	—	TPC	RCW	RLW
Initial value	0	0	0	0	1	0	0	0
Read/Write	R/W	R/W	R/W	R/W	—	R/W	R/W	R/W

DRCRB is an 8-bit readable/writable register that selects the number of address multiplex column address bits for the DRAM interface, the column address strobe output pin, enabling or disabling of refresh cycle insertion, the number of precharge cycles, enabling or disabling of wait state insertion between $\overline{\text{RAS}}$ and $\overline{\text{CAS}}$, and enabling or disabling of wait state insertion in refresh cycles.

DRCRB is initialized to H'08 by a reset and in hardware standby mode. It is not initialized in software standby mode.

The settings in this register are invalid when bits DRAS2 to DRAS0 in DRCRA are all 0.

Bits 7 and 6—Multiplex Control 1 and 0 (MXC1, MXC0): These bits select the row address/column address multiplexing method used on the DRAM interface. In burst operation, the row address used for comparison is determined by the setting of these bits and the bus width of the relevant area set in ABWCR.

Bit 7 MXC1	Bit 6 MXC0	Description	
0	0	Column address: 8 bits	
		Compared address:	
		Modes 1, 2	8-bit access space A_{19} to A_8
			16-bit access space A_{19} to A_9
	Modes 3, 4	8-bit access space A_{23} to A_8	
		16-bit access space A_{23} to A_9	
		1	Column address: 9 bits
			Compared address:
Modes 1, 2	8-bit access space A_{19} to A_9		
	16-bit access space A_{19} to A_{10}		
Modes 3, 4	8-bit access space A_{23} to A_9		
	16-bit access space A_{23} to A_{10}		
	1	0	Column address: 10 bits
			Compared address:
Modes 1, 2			8-bit access space A_{19} to A_{10}
			16-bit access space A_{19} to A_{11}
Modes 3, 4		8-bit access space A_{23} to A_{10}	
		16-bit access space A_{23} to A_{11}	
		1	Illegal setting

Bit 5—CAS Output Pin Select (CSEL): Selects the \overline{UCAS} and \overline{LCAS} output pins when areas 2 to 5 are designated as DRAM space.

Bit 5 CSEL	Description
0	PB4 and PB5 selected as \overline{UCAS} and \overline{LCAS} output pins (Initial value)
1	HWR and LWR selected as \overline{UCAS} and \overline{LCAS} output pins

Bit 4—Refresh Cycle Enable (RCYCE): CAS-before-RAS enables or disables refresh cycle insertion. When none of areas 2 to 5 has been designated as DRAM space, refresh cycles are not inserted regardless of the setting of this bit.

Bit 4 RCYCE	Description	
0	Refresh cycles disabled	(Initial value)
1	DRAM refresh cycles enabled	

Bit 3—Reserved: This bit cannot be modified and is always read as 1.

Bit 2—TP Cycle Control (TPC): Selects whether a 1-state or two-state precharge cycle (T_p) is to be used for DRAM read/write cycles and CAS-before-RAS refresh cycles. The setting of this bit does not affect the self-refresh function.

Bit 2 TPC	Description	
0	1-state precharge cycle inserted	(Initial value)
1	2-state precharge cycle inserted	

Bit 1— $\overline{\text{RAS}}\text{-}\overline{\text{CAS}}$ Wait (RCW): Controls wait state (T_{rw}) insertion between T_r and T_{c1} in DRAM read/write cycles. The setting of this bit does not affect refresh cycles.

Bit 1 RCW	Description	
0	Wait state (T_{rw}) insertion disabled	(Initial value)
1	One wait state (T_{rw}) inserted	

Bit 0—Refresh Cycle Wait Control (RLW): Controls wait state (T_{RW}) insertion for CAS-before-RAS refresh cycles. The setting of this bit does not affect DRAM read/write cycles.

Bit 0 RLW	Description	
0	Wait state (T_{RW}) insertion disabled	(Initial value)
1	One wait state (T_{RW}) inserted	

6.2.9 Refresh Timer Control/Status Register (RTMCSR)

Bit	7	6	5	4	3	2	1	0
	CMF	CMIE	CKS2	CKS1	CKS0	—	—	—
Initial value	0	0	0	0	0	1	1	1
Read/Write	R(W)*	R/W	R/W	R/W	R/W	—	—	—

RTMCSR is an 8-bit readable/writable register that selects the refresh timer counter clock. When the refresh timer is used as an interval timer, RTMCSR also enables or disables interrupt requests. Bits 7 and 6 of RTMCSR are initialized to 0 by a reset and in the standby modes. Bits 5 to 3 are initialized to 0 by a reset and in hardware standby mode; they are not initialized in software standby mode.

Note: Only 0 can be written to clear the flag.

Bit 7—Compare Match Flag (CMF): Status flag that indicates a match between the values of RTCNT and RTCOR.

Bit 7

CMF	Description
0	[Clearing conditions] <ul style="list-style-type: none"> When the chip is reset and in standby mode Read CMF when CMF = 1, then write 0 in CMF (Initial value)
1	[Setting condition] When RTCNT = RTCOR

Bit 6—Compare Match Interrupt Enable (CMIE): Enables or disables the CMI interrupt requested when the CMF flag is set to 1 in RTMCSR. The CMIE bit is always cleared to 0 when any of areas 2 to 5 is designated as DRAM space.

Bit 6

CMIE	Description
0	The CMI interrupt requested by CMF is disabled (Initial value)
1	The CMI interrupt requested by CMF is enabled

Bits 5 to 3—Refresh Counter Clock Select (CKS2 to CKS0): These bits select the clock to be input to RTCNT from among 7 clocks obtained by dividing the system clock (ϕ). When the input clock is selected with bits CKS2 to CKS0, RTCNT begins counting up.

Bit 5 CKS2	Bit 4 CKS1	Bit 3 CKS0	Description
0	0	0	Count operation halted (Initial value)
		1	$\phi/2$ used as counter clock
	1	0	$\phi/8$ used as counter clock
		1	$\phi/32$ used as counter clock
1	0	0	$\phi/128$ used as counter clock
		1	$\phi/512$ used as counter clock
	1	0	$\phi/2048$ used as counter clock
		1	$\phi/4096$ used as counter clock

Bits 2 to 0—Reserved: These bits cannot be modified and are always read as 1.

6.2.10 Refresh Timer Counter (RTCNT)

Bit	7	6	5	4	3	2	1	0
Initial value	0	0	0	0	0	0	0	0
Read/Write	R/W	R/W	R/W	R/W	R/W	R/W	R/W	R/W

RTCNT is an 8-bit readable/writable up-counter.

RTCNT is incremented by an internal clock selected by bits CKS2 to CKS0 in RTMCSR. When RTCNT matches RTCOR (compare match), the CMF flag in RTMCSR is set to 1 and RTCNT is cleared to H'00. If the RCYCE bit in DRCRB is set to 1 at this time, a refresh cycle is started. Also, if the CMIE bit in RTMCSR is set to 1, a compare match interrupt (CMI) is generated.

RTCNT is initialized to H'00 by a reset and in standby mode.

6.2.11 Refresh Time Constant Register (RTCOR)

Bit	7	6	5	4	3	2	1	0
Initial value	1	1	1	1	1	1	1	1
Read/Write	R/W	R/W	R/W	R/W	R/W	R/W	R/W	R/W

RTCOR is an 8-bit readable/writable register that sets the RTCNT compare-match interval.

RTCOR and RTCNT are constantly compared. When their values match, the CMF flag is set to 1 in RTMCSR, and RTCNT is simultaneously cleared to H'00.

RTCOR is initialized to H'FF by a reset and in hardware standby mode. It is not initialized in software standby mode.

Note: Only byte access should be used with this register.

6.3 Operation

6.3.1 Area Division

The external address space is divided into areas 0 to 7. Each area has a size of 128 kbytes in the 1-Mbyte modes, or 2-Mbytes in the 16-Mbyte modes. Figure 6.2 shows a general view of the memory map.

H' 00000	Area 0 (128 kbytes)	H' 000000	Area 0 (2 Mbytes)
H' 1FFFF		H' 1FFFFFF	
H' 20000	Area 1 (128 kbytes)	H' 200000	Area 1 (2 Mbytes)
H' 3FFFF		H' 3FFFFFF	
H' 40000	Area 2 (128 kbytes)	H' 400000	Area 2 (2 Mbytes)
H' 5FFFF		H' 5FFFFFF	
H' 60000	Area 3 (128 kbytes)	H' 600000	Area 3 (2 Mbytes)
H' 7FFFF		H' 7FFFFFF	
H' 80000	Area 4 (128 kbytes)	H' 800000	Area 4 (2 Mbytes)
H' 9FFFF		H' 9FFFFFF	
H' A0000	Area 5 (128 kbytes)	H' A00000	Area 5 (2 Mbytes)
H' BFFFF		H' BFFFFFF	
H' C0000	Area 6 (128 kbytes)	H' C00000	Area 6 (2 Mbytes)
H' DFFFF		H' DFFFFFF	
H' E0000	Area 7 (128 Mbytes)	H' E00000	Area 7 (2 Mbytes)
H' FFFFF		H' FFFFFFF	
(a) 1-Mbyte modes (modes 1 and 2)		(b) 16-Mbyte modes (modes 3 and 4)	

Figure 6.2 Access Area Map for Each Operating Mode

Chip select signals (\overline{CS}_0 to \overline{CS}_7) can be output for areas 0 to 7. The bus specifications for each area are selected in ABWCR, ASTCR, WCRH, and WCRL.

In 16-Mbyte mode, the area division units can be selected with the RDEA bit in BCR.

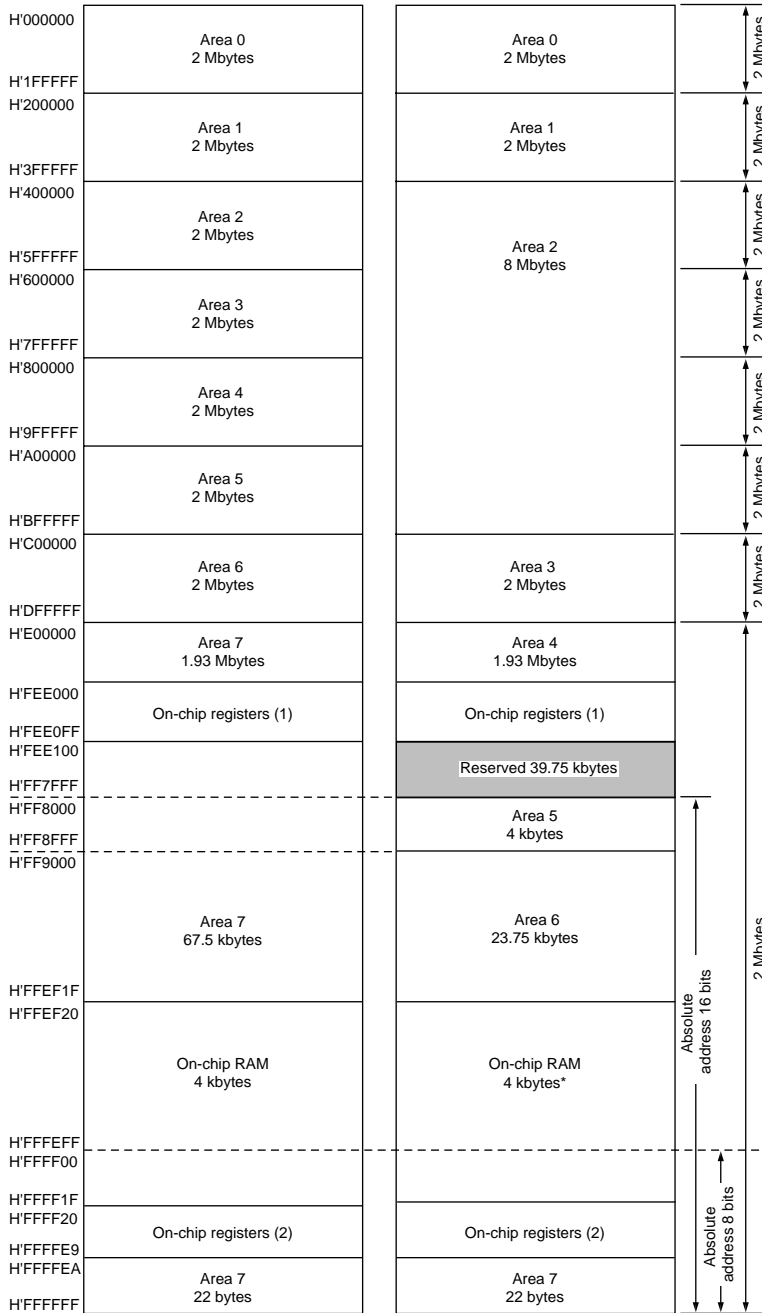

Note: * Area 6 when the RAME bit is cleared.

Figure 6.3 Memory Map in 16-Mbyte Mode (H8/3007)

6.3.2 Bus Specifications

The external space bus specifications consist of three elements: (1) bus width, (2) number of access states, and (3) number of program wait states.

The bus width and number of access states for on-chip memory and registers are fixed, and are not affected by the bus controller.

Bus Width: A bus width of 8 or 16 bits can be selected with ABWCR. An area for which an 8-bit bus is selected functions as an 8-bit access space, and an area for which a 16-bit bus is selected functions as a 16-bit access space.

If all areas are designated for 8-bit access, 8-bit bus mode is set; if any area is designated for 16-bit access, 16-bit bus mode is set.

Number of Access States: Two or three access states can be selected with ASTCR. An area for which two-state access is selected functions as a two-state access space, and an area for which three-state access is selected functions as a three-state access space.

DRAM space is accessed in four states regardless of the ASTCR settings.

When two-state access space is designated, wait insertion is disabled.

Number of Program Wait States: When three-state access space is designated in ASTCR, the number of program wait states to be inserted automatically is selected with WCRH and WCRL. From 0 to 3 program wait states can be selected.

When ASTCR is cleared to 0 for DRAM space, a program wait (T_{c1} - T_{c2} wait) is not inserted. Also, no program wait is inserted in burst ROM space burst cycles.

Table 6.3 shows the bus specifications for each basic bus interface area.

Table 6.3 Bus Specifications for Each Area (Basic Bus Interface)

ABWCR	ASTCR	WCRH/WCRL		Bus Specifications (Basic Bus Interface)		
ABWn	ASTn	Wn1	Wn0	Bus Width	Access States	Program Wait States
0	0	—	—	16	2	0
	1	0	0		3	0
			1		1	
			0		2	
1	1	0	3			
		1	2			
		0	3			
1	0	—	—	8	2	0
	1	0	0		3	0
			1		1	
			0		2	
1	1	0	3			
		1	3			

6.3.3 Memory Interfaces

The H8/3006 and H8/3007 memory interfaces comprise a basic bus interface that allows direct connection of ROM, SRAM, and so on; a DRAM interface that allows direct connection of DRAM; and a burst ROM interface that allows direct connection of burst ROM. The interface can be selected independently for each area.

An area for which the basic bus interface is designated functions as normal space, an area for which the DRAM interface is designated functions as DRAM space, and area 0 for which the burst ROM interface is designated functions as burst ROM space.

6.3.4 Chip Select Signals

For each of areas 0 to 7, the H8/3006 and H8/3007 can output a chip select signal (\overline{CS}_0 to \overline{CS}_7) that goes low when the corresponding area is selected. Figure 6.4 shows the output timing of a \overline{CS}_n signal.

Output of \overline{CS}_0 to \overline{CS}_3 : Output of \overline{CS}_0 to \overline{CS}_3 is enabled or disabled in the data direction register (DDR) of the corresponding port.

A reset leaves pin \overline{CS}_0 in the output state and pins \overline{CS}_1 to \overline{CS}_3 in the input state. To output chip select signals \overline{CS}_1 to \overline{CS}_3 , the corresponding DDR bits must be set to 1. For details, see section 8, I/O Ports.

Output of \overline{CS}_4 to \overline{CS}_7 : Output of \overline{CS}_4 to \overline{CS}_7 is enabled or disabled in the chip select control register (CSCR). A reset leaves pins \overline{CS}_4 to \overline{CS}_7 in the input state. To output chip select signals \overline{CS}_4 to \overline{CS}_7 , the corresponding CSCR bits must be set to 1. For details, see section 8, I/O Ports.

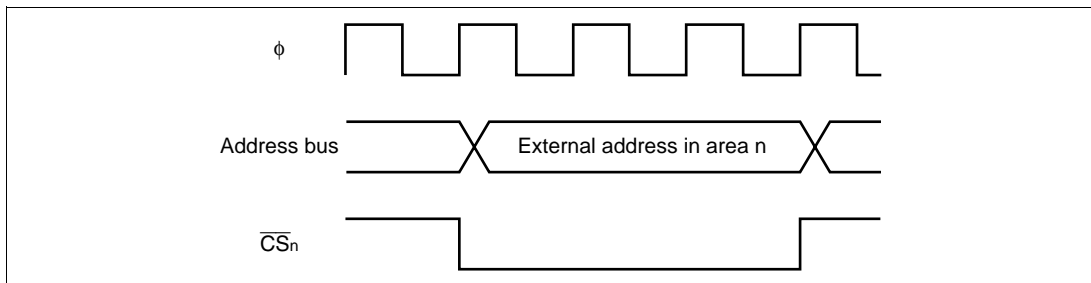

Figure 6.4 \overline{CS}_n Signal Output Timing (n = 0 to 7)

When the on-chip RAM and on-chip registers are accessed, \overline{CS}_0 to \overline{CS}_7 remain high. The \overline{CS}_n signals are decoded from the address signals. They can be used as chip select signals for SRAM and other devices.

6.4 Basic Bus Interface

6.4.1 Overview

The basic bus interface enables direct connection of ROM, SRAM, and so on.

The bus specifications can be selected with ABWCR, ASTCR, WCRH, and WCRL (see table 6.3).

6.4.2 Data Size and Data Alignment

Data sizes for the CPU and other internal bus masters are byte, word, and longword. The bus controller has a data alignment function, and when accessing external space, controls whether the upper data bus (D_{15} to D_8) or lower data bus (D_7 to D_0) is used according to the bus specifications for the area being accessed (8-bit access area or 16-bit access area) and the data size.

8-Bit Access Areas: Figure 6.5 illustrates data alignment control for 8-bit access space. With 8-bit access space, the upper data bus (D_{15} to D_8) is always used for accesses. The amount of data that can be accessed at one time is one byte: a word access is performed as two byte accesses, and a longword access, as four byte accesses.

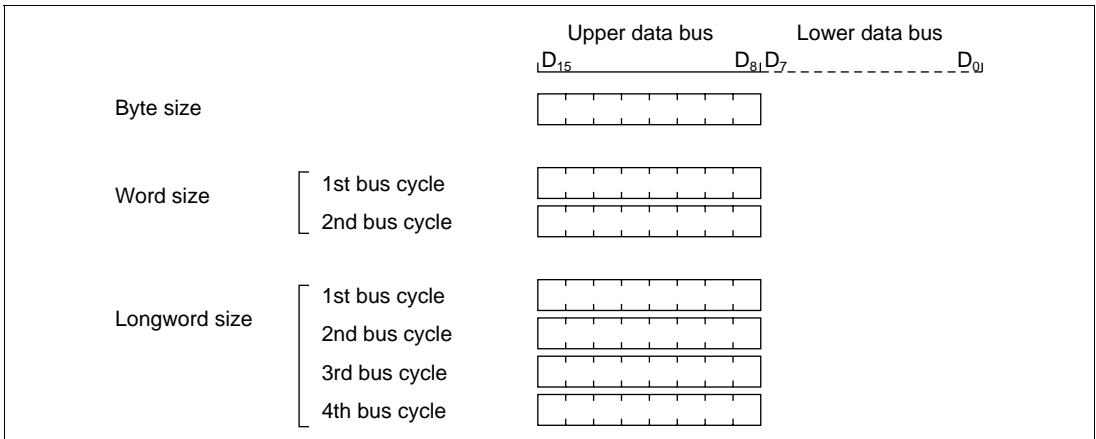

Figure 6.5 Access Sizes and Data Alignment Control (8-Bit Access Area)

16-Bit Access Areas: Figure 6.6 illustrates data alignment control for 16-bit access areas. With 16-bit access areas, the upper data bus (D_{15} to D_8) and lower data bus (D_7 to D_0) are used for accesses. The amount of data that can be accessed at one time is one byte or one word, and a longword access is executed as two word accesses.

In byte access, whether the upper or lower data bus is used is determined by whether the address is even or odd. The upper data bus is used for an even address, and the lower data bus for an odd address.

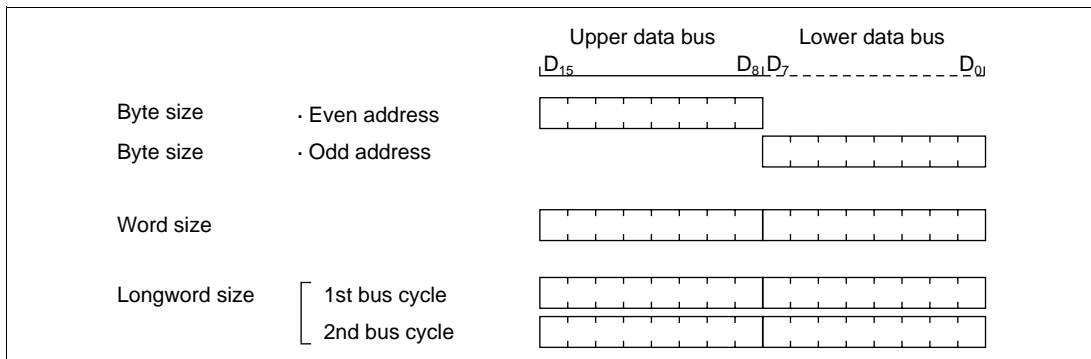

Figure 6.6 Access Sizes and Data Alignment Control (16-Bit Access Area)

6.4.3 Valid Strobes

Table 6.4 shows the data buses used, and the valid strobes, for the access spaces.

In a read, the \overline{RD} signal is valid for both the upper and the lower half of the data bus.

In a write, the \overline{HWR} signal is valid for the upper half of the data bus, and the \overline{LWR} signal for the lower half.

Table 6.4 Data Buses Used and Valid Strobes

Area	Access Size	Read/Write	Address	Valid Strobe	Upper Data Bus (D ₁₅ to D ₈)	Lower Data Bus (D ₇ to D ₀)
8-bit access area	Byte	Read	—	\overline{RD}	Valid	Invalid
		Write	—	\overline{HWR}		Undetermined data
16-bit access area	Byte	Read	Even	\overline{RD}	Valid	Invalid
			Odd		Invalid	Valid
		Write	Even	\overline{HWR}	Valid	Undetermined data
			Odd	\overline{LWR}	Undetermined data	Valid
	Word	Read	—	\overline{RD}	Valid	Valid
		Write	—	$\overline{HWR}, \overline{LWR}$	Valid	Valid

- Notes: 1. Undetermined data means that unpredictable data is output.
2. Invalid means that the bus is in the input state and the input is ignored.

6.4.4 Memory Areas

The initial state of each area is basic bus interface, three-state access space. The initial bus width is selected according to the operating mode. The bus specifications described here cover basic items only, and the following sections should be referred to for further details: 6.4, Basic Bus Interface, 6.5, DRAM Interface, 6.8, Burst ROM Interface.

Area 0: When area 0 external space is accessed, the \overline{CS}_0 signal can be output.

Either basic bus interface or burst ROM interface can be selected for area 0.

The size of area 0 is 128 kbytes in modes 1 and 2, and 2 Mbytes in modes 3 and 4.

Areas 1 and 6: When area 1 and 6 external space is accessed, the \overline{CS}_1 and \overline{CS}_6 pin signals respectively can be output.

Only the basic bus interface can be used for areas 1 and 6.

The size of areas 1 and 6 is 128 kbytes in modes 1 and 2, and 2 Mbytes in modes 3 and 4.

Areas 2 to 5: When area 2 to 5 external space is accessed, signals \overline{CS}_2 to \overline{CS}_5 can be output.

Basic bus interface or DRAM interface can be selected for areas 2 to 5. With the DRAM interface, signals \overline{CS}_2 to \overline{CS}_5 are used as \overline{RAS} signals.

The size of areas 2 to 5 is 128 kbytes in modes 1 and 2, and 2 Mbytes in modes 3 and 4.

Area 7: Area 7 includes the on-chip RAM and registers. The space excluding the on-chip RAM and registers is external space. The on-chip RAM is enabled when the RAME bit in the system control register (SYSCR) is set to 1; when the RAME bit is cleared to 0, the on-chip RAM is disabled and the corresponding space becomes external space .

When area 7 external space is accessed, the \overline{CS}_7 signal can be output.

Only the basic bus interface can be used for the area 7 memory interface.

The size of area 7 is 128 kbytes in modes 1 and 2, and 2 Mbytes in modes 3 and 4.

6.4.5 Basic Bus Control Signal Timing

8-Bit, Three-State-Access Areas

Figure 6.7 shows the timing of bus control signals for an 8-bit, three-state-access area. The upper data bus (D_{15} to D_8) is used in accesses to these areas. The \overline{LWR} pin is always high. Wait states can be inserted.

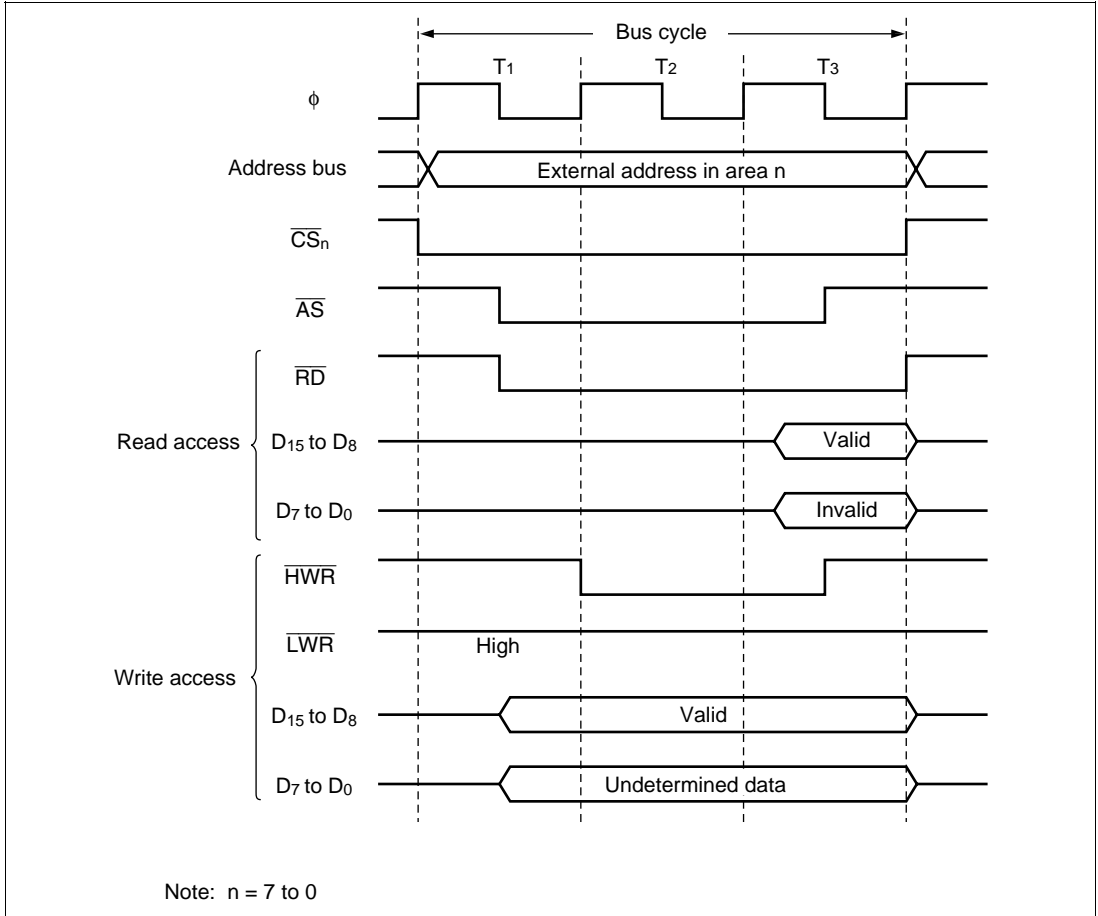

Figure 6.7 Bus Control Signal Timing for 8-Bit, Three-State-Access Area

8-Bit, Two-State-Access Areas

Figure 6.8 shows the timing of bus control signals for an 8-bit, two-state-access area. The upper data bus (D_{15} to D_8) is used in accesses to these areas. The \overline{LWR} pin is always high. Wait states cannot be inserted.

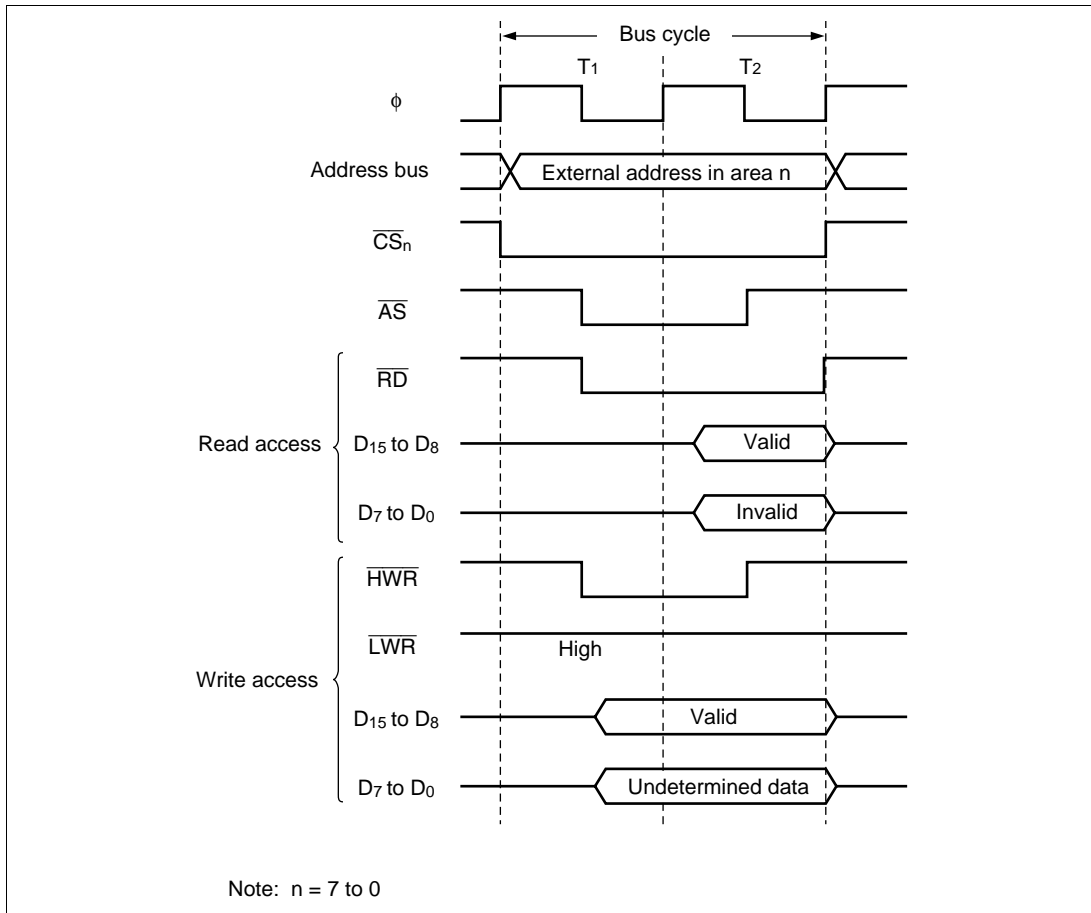
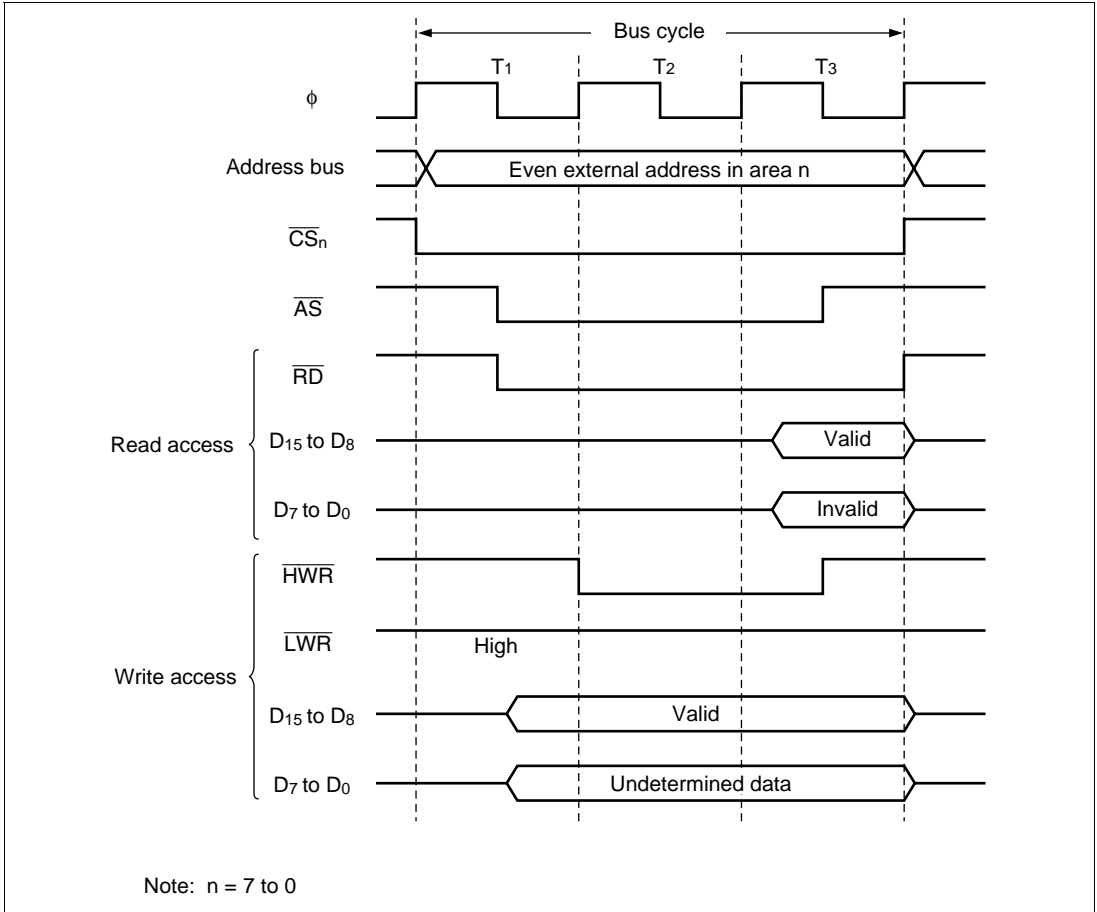

Figure 6.8 Bus Control Signal Timing for 8-Bit, Two-State-Access Area

16-Bit, Three-State-Access Areas

Figures 6.9 to 6.11 show the timing of bus control signals for a 16-bit, three-state-access area. In these areas, the upper data bus (D_{15} to D_8) is used in accesses to even addresses and the lower data bus (D_7 to D_0) in accesses to odd addresses. Wait states can be inserted.



**Figure 6.9 Bus Control Signal Timing for 16-Bit, Three-State-Access Area (1)
(Byte Access to Even Address)**

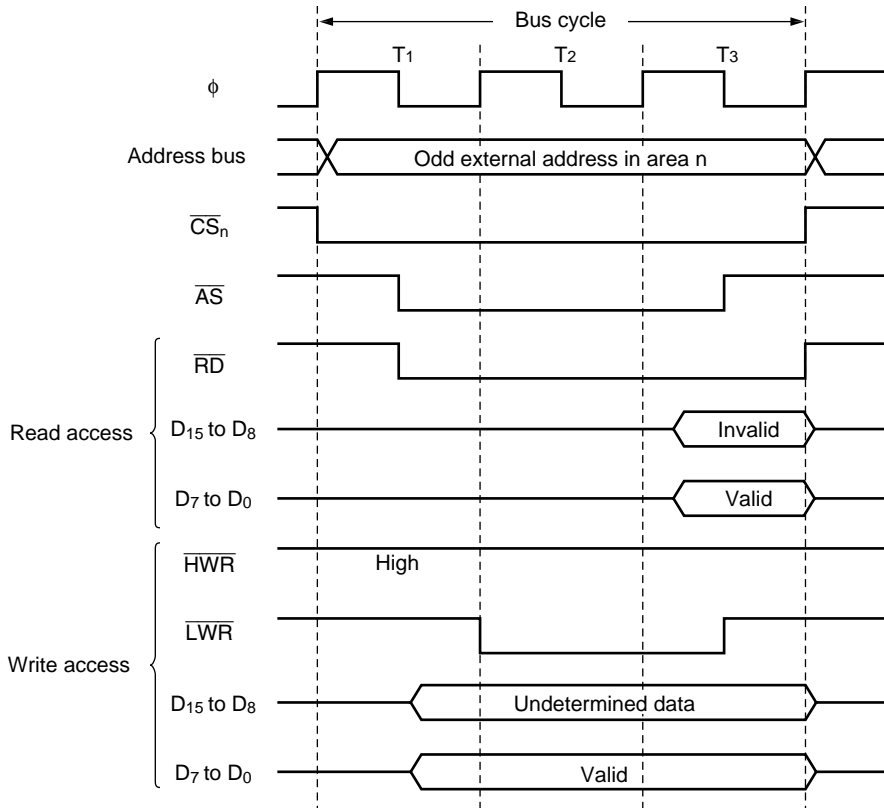

Note: n = 7 to 0

**Figure 6.10 Bus Control Signal Timing for 16-Bit, Three-State-Access Area (2)
(Byte Access to Odd Address)**

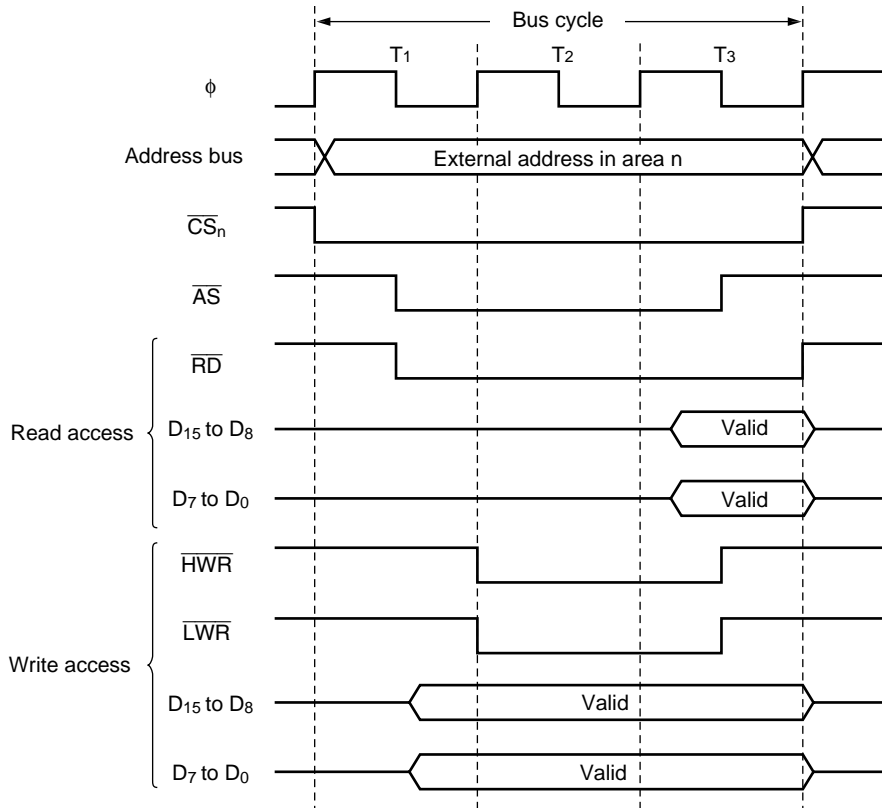

Figure 6.11 Bus Control Signal Timing for 16-Bit, Three-State-Access Area (3) (Word Access)

16-Bit, Two-State-Access Areas: Figures 6.12 to 6.14 show the timing of bus control signals for a 16-bit, two-state-access area. In these areas, the upper data bus (D_{15} to D_8) is used in accesses to even addresses and the lower data bus (D_7 to D_0) in accesses to odd addresses. Wait states cannot be inserted.

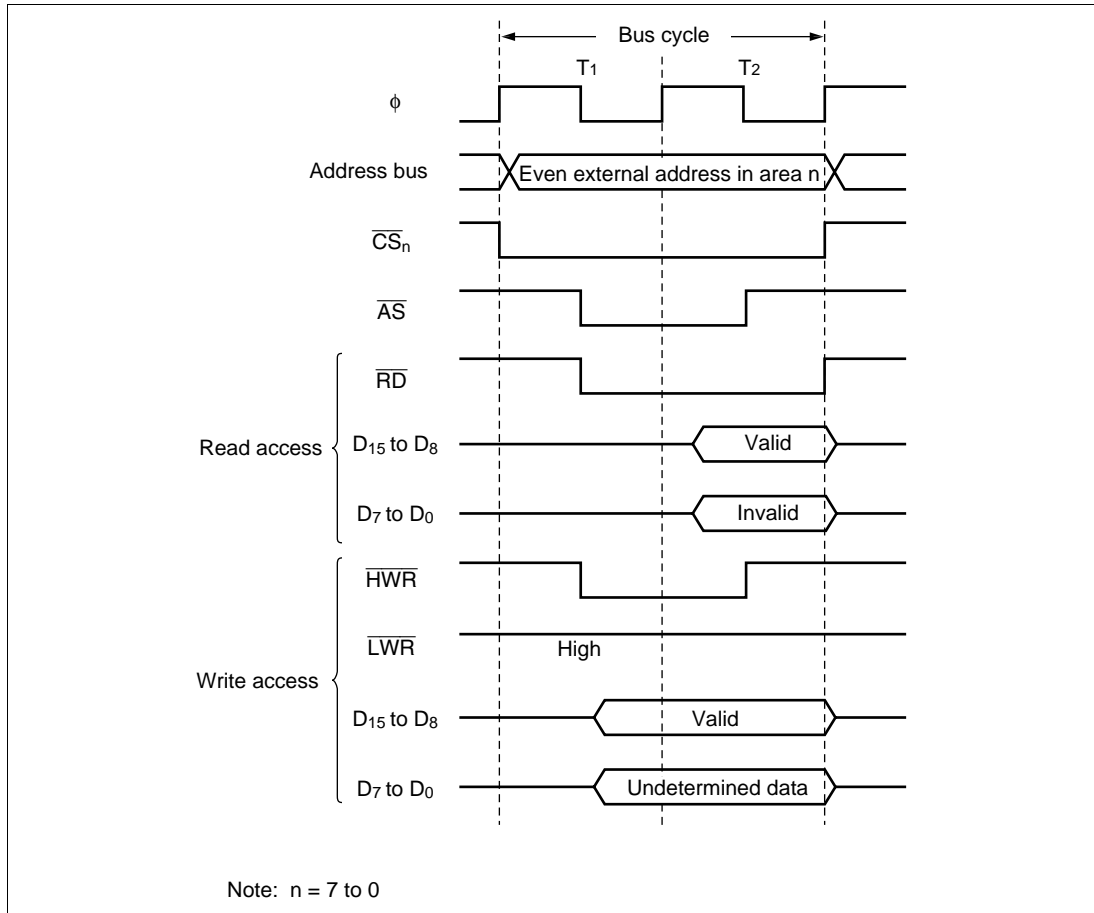
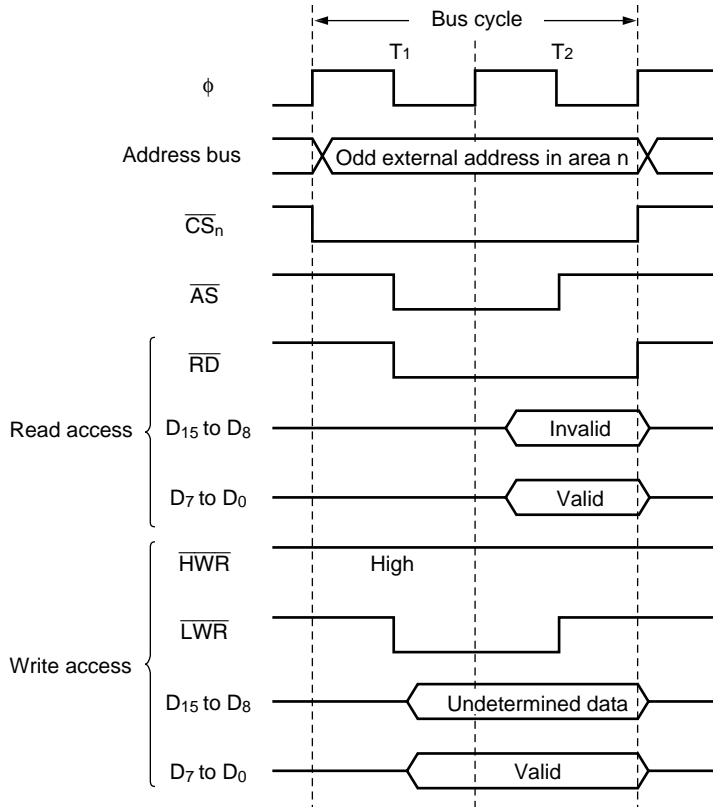
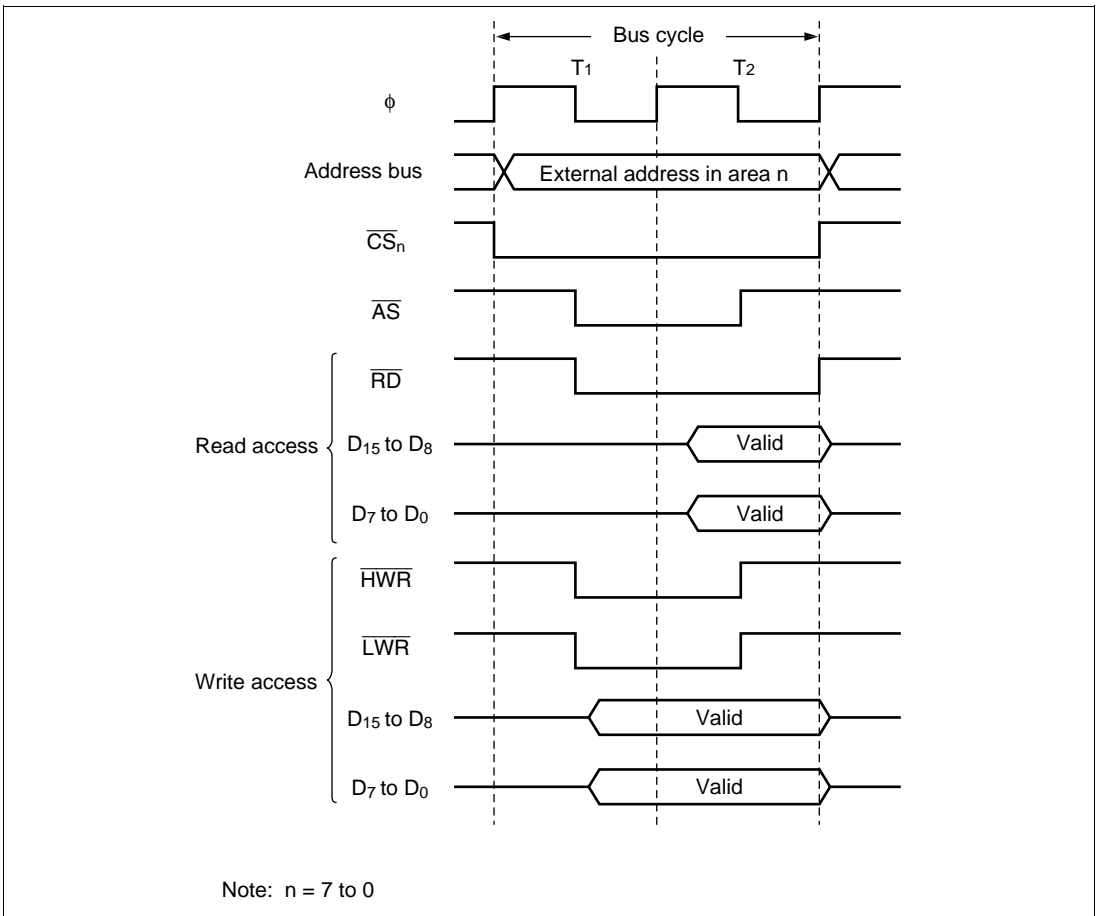

Figure 6.12 Bus Control Signal Timing for 16-Bit, Two-State-Access Area (1)
(Byte Access to Even Address)



Note: n = 7 to 0

**Figure 6.13 Bus Control Signal Timing for 16-Bit, Two-State-Access Area (2)
(Byte Access to Odd Address)**



**Figure 6.14 Bus Control Signal Timing for 16-Bit, Two-State-Access Area (3)
(Word Access)**

6.4.6 Wait Control

When accessing external space, the H8/3006 and H8/3007 can extend the bus cycle by inserting one or more wait states (T_w). There are two ways of inserting wait states: (1) program wait insertion and (2) pin wait insertion using the $\overline{\text{WAIT}}$ pin.

Program Wait Insertion: From 0 to 3 wait states can be inserted automatically between the T_2 state and T_3 state on an individual area basis in three-state access space, according to the settings of WCRH and WCRL.

Pin Wait Insertion: Setting the WAITE bit in BCR to 1 enables wait insertion by means of the $\overline{\text{WAIT}}$ pin. When external space is accessed in this state, a program wait is first inserted. If the $\overline{\text{WAIT}}$ pin is low at the falling edge of ϕ in the last T_2 or T_w state, another T_w state is inserted. If the $\overline{\text{WAIT}}$ pin is held low, T_w states are inserted until it goes high.

This is useful when inserting four or more T_w states, or when changing the number of T_w states for different external devices.

The WAITE bit setting applies to all areas. Pin waits cannot be inserted in DRAM space.

Figure 6.15 shows an example of the timing for insertion of one program wait state in 3-state space.

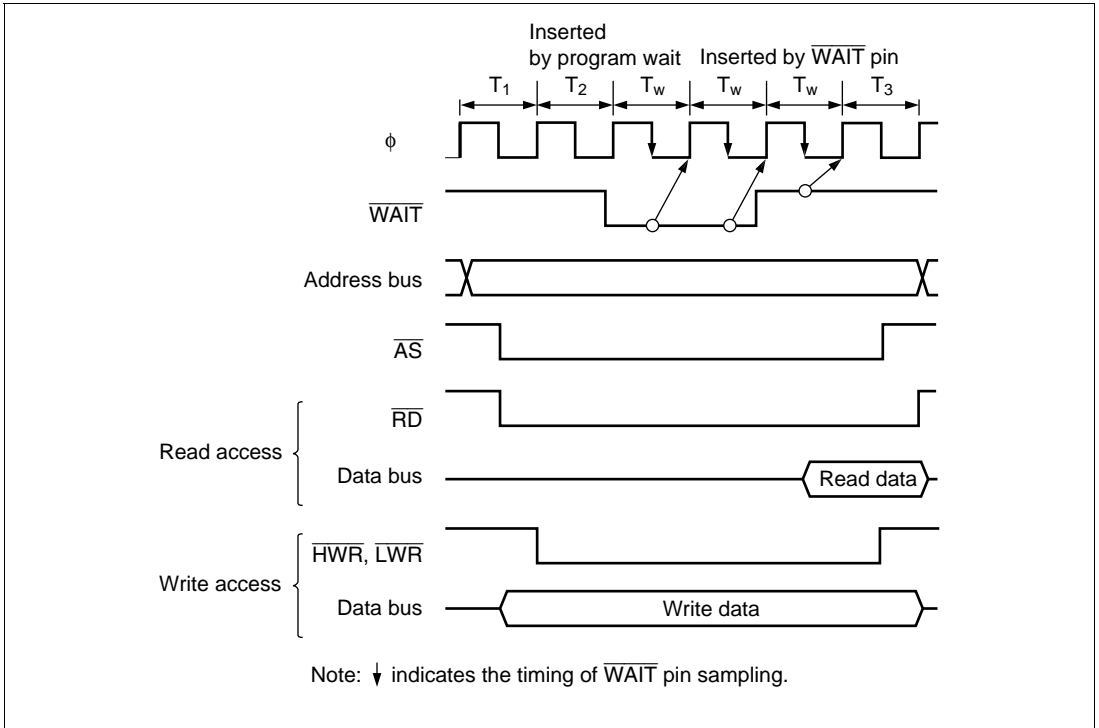

Figure 6.15 Example of Wait State Insertion Timing

6.5 DRAM Interface

6.5.1 Overview

The H8/3006 and H8/3007 are provided with a DRAM interface with functions for DRAM control signal ($\overline{\text{RAS}}$, $\overline{\text{UCAS}}$, $\overline{\text{LCAS}}$, $\overline{\text{WE}}$) output, address multiplexing, and refreshing, that direct connection of DRAM. In the expanded modes, external address space areas 2 to 5 can be designated as DRAM space accessed via the DRAM interface. A data bus width of 8 or 16 bits can be selected for DRAM space by means of a setting in ABWCR. When a 16-bit data bus width is selected, CAS is used for byte access control. In the case of $\times 16$ -bit organization DRAM, therefore, the 2-CAS type can be connected. A fast page mode is supported in addition to the normal read and write access modes.

6.5.2 DRAM Space and $\overline{\text{RAS}}$ Output Pin Settings

Designation of areas 2 to 5 as DRAM space, and selection of the $\overline{\text{RAS}}$ output pin for each area designated as DRAM space, is performed by setting bits DRAS2 to DRAS0 in DRCRA. Table 6.5 shows the correspondence between the settings of bits DRAS2 to DRAS0 and the selected DRAM space and $\overline{\text{RAS}}$ output pin.

When an arbitrary value has been set in DRAS2 to DRAS0, a write of a different value other than 000 must not be performed.

Table 6.5 Settings of Bits DRAS2 to DRAS0 and Corresponding DRAM Space ($\overline{\text{RAS}}$ Output Pin)

DRAS2	DRAS1	DRAS0	Area 5	Area 4	Area 3	Area 2
0	0	0	Normal space	Normal space	Normal space	Normal space
		1	Normal space	Normal space	Normal space	DRAM space ($\overline{\text{CS}}_2$)
	1	0	Normal space	Normal space	DRAM space ($\overline{\text{CS}}_3$)	DRAM space ($\overline{\text{CS}}_2$)
		1	Normal space	Normal space	DRAM space ($\overline{\text{CS}}_2$)*	
1	0	0	Normal space	DRAM space ($\overline{\text{CS}}_4$)	DRAM space ($\overline{\text{CS}}_3$)	DRAM space ($\overline{\text{CS}}_2$)
		1	DRAM space ($\overline{\text{CS}}_5$)	DRAM space ($\overline{\text{CS}}_4$)	DRAM space ($\overline{\text{CS}}_3$)	DRAM space ($\overline{\text{CS}}_2$)
	1	0	DRAM space ($\overline{\text{CS}}_4$)*		DRAM space ($\overline{\text{CS}}_2$)*	
		1	DRAM space ($\overline{\text{CS}}_2$)*			

Note: * A single $\overline{\text{CS}}_n$ pin serves as a common $\overline{\text{RAS}}$ output pin for a number of areas. Unused $\overline{\text{CS}}_n$ pins can be used as input/output ports.

6.5.3 Address Multiplexing

When DRAM space is accessed, the row address and column address are multiplexed. The address multiplexing method is selected with bits MXC1 and MXC0 in DRCRB according to the number of bits in the DRAM column address. Table 6.6 shows the correspondence between the settings of MXC1 and MXC0 and the address multiplexing method.

Table 6.6 Settings of Bits MXC1 and MXC0 and Address Multiplexing Method

	DRCRB		Column Address	Address Pins															
	MXC1	MXC0	Bits	A ₂₃ to A ₁₃	A ₁₂	A ₁₁	A ₁₀	A ₉	A ₈	A ₇	A ₆	A ₅	A ₄	A ₃	A ₂	A ₁	A ₀		
Row address	0	0	8 bits	A ₂₃ to A ₁₃	A ₂₀ *	A ₁₉	A ₁₈	A ₁₇	A ₁₆	A ₁₅	A ₁₄	A ₁₃	A ₁₂	A ₁₁	A ₁₀	A ₉	A ₈		
		1	9 bits	A ₂₃ to A ₁₃	A ₁₂	A ₂₀ *	A ₁₉	A ₁₈	A ₁₇	A ₁₆	A ₁₅	A ₁₄	A ₁₃	A ₁₂	A ₁₁	A ₁₀	A ₉		
	1	0	10 bits	A ₂₃ to A ₁₃	A ₁₂	A ₁₁	A ₂₀ *	A ₁₉	A ₁₈	A ₁₇	A ₁₆	A ₁₅	A ₁₄	A ₁₃	A ₁₂	A ₁₁	A ₁₀		
		1	Illegal setting	—	—	—	—	—	—	—	—	—	—	—	—	—	—		
Column address	—	—	—	A ₂₃ to A ₁₃	A ₁₂	A ₁₁	A ₁₀	A ₉	A ₈	A ₇	A ₆	A ₅	A ₄	A ₃	A ₂	A ₁	A ₀		

Note: * Row address bit A₂₀ is not multiplexed in 1-Mbyte mode.

6.5.4 Data Bus

If the bit in ABWCR corresponding to an area designated as DRAM space is set to 1, that area is designated as 8-bit DRAM space; if the bit is cleared to 0, the area is designated as 16-bit DRAM space. In 16-bit DRAM space, × 16-bit organization DRAM can be connected directly.

In 8-bit DRAM space the upper half of the data bus, D₁₅ to D₈, is enabled, while in 16-bit DRAM space both the upper and lower halves of the data bus, D₁₅ to D₀, are enabled.

Access sizes and data alignment are the same as for the basic bus interface: see section 6.4.2, Data Size and Data Alignment.

6.5.5 Pins Used for DRAM Interface

Table 6.7 shows the pins used for DRAM interfacing and their functions.

Table 6.7 DRAM Interface Pins

Pin	With DRAM Designated	Name	I/O	Function
PB4	\overline{UCAS}	Upper column address strobe	Output	Upper column address strobe for DRAM space access (when CSEL = 0 in DRCRB)
PB5	\overline{LCAS}	Lower column address strobe	Output	Lower column address strobe for DRAM space access (when CSEL = 0 in DRCRB)
HWR	\overline{UCAS}	Upper column address strobe	Output	Upper column address strobe for DRAM space access (when CSEL = 1 in DRCRB)
LWR	\overline{LCAS}	Lower column address strobe	Output	Lower column address strobe for DRAM space access (when CSEL = 1 in DRCRB)
\overline{CS}_2	\overline{RAS}_2	Row address strobe 2	Output	Row address strobe for DRAM space access
\overline{CS}_3	\overline{RAS}_3	Row address strobe 3	Output	Row address strobe for DRAM space access
\overline{CS}_4	\overline{RAS}_4	Row address strobe 4	Output	Row address strobe for DRAM space access
\overline{CS}_5	\overline{RAS}_5	Row address strobe 5	Output	Row address strobe for DRAM space access
\overline{RD}	\overline{WE}	Write enable	Output	Write enable for DRAM space write access*
P80	\overline{RFSH}	Refresh	Output	Goes low in refresh cycle
A_{12} to A_0	A_{12} to A_0	Address	Output	Row address/column address multiplexed output
D_{15} to D_0	D_{15} to D_0	Data	I/O	Data input/output pins

Note: * Fixed high in a read access.

6.5.6 Basic Timing

Figure 6.16 shows the basic access timing for DRAM space. The basic DRAM access timing is four states: one precharge cycle (T_p) state, one row address output cycle (T_r) state, and two column address output cycle (T_{c1} , T_{c2}) states. Unlike the basic bus interface, the corresponding bits in ASTCR control only enabling or disabling of wait insertion between T_{c1} and T_{c2} , and do not affect the number of access states. When the corresponding bit in ASTCR is cleared to 0, wait states cannot be inserted between T_{c1} and T_{c2} in the DRAM access cycle.

If a DRAM read/write cycle is followed by an access cycle for an external area other than DRAM space when \overline{HWR} and \overline{LWR} are selected as the \overline{UCAS} and \overline{LCAS} output pins, an idle cycle (T_i) is inserted unconditionally immediately after the DRAM access cycle. See section 6.9, Idle Cycle, for details.

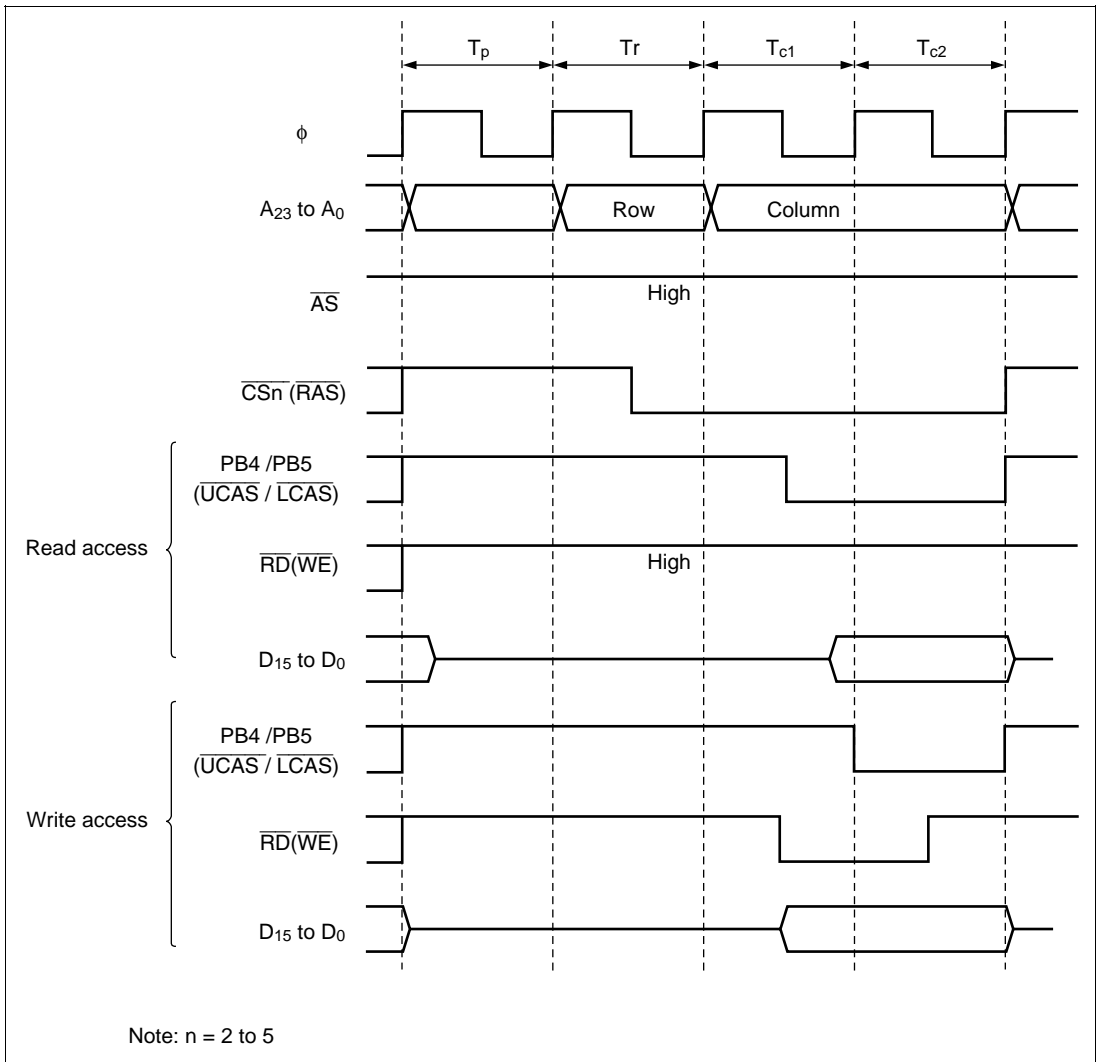

Figure 6.16 Basic Access Timing (CSEL = 0 in DRCRB)

6.5.7 Precharge State Control

In the H8/3006 and H8/3007, provision is made for the DRAM RAS precharge time by always inserting one RAS precharge state (T_p) when DRAM space is accessed. This can be changed to two T_p states by setting the TPC bit to 1 in DRCRB. The optimum number of T_p cycles should be set according to the DRAM connected and the operating frequency of the H8/3006 and H8/3007 chip. Figure 6.17 shows the timing when two T_p states are inserted.

When the TCP bit is set to 1, two T_p states are also used for CAS-before-RAS refresh cycles.

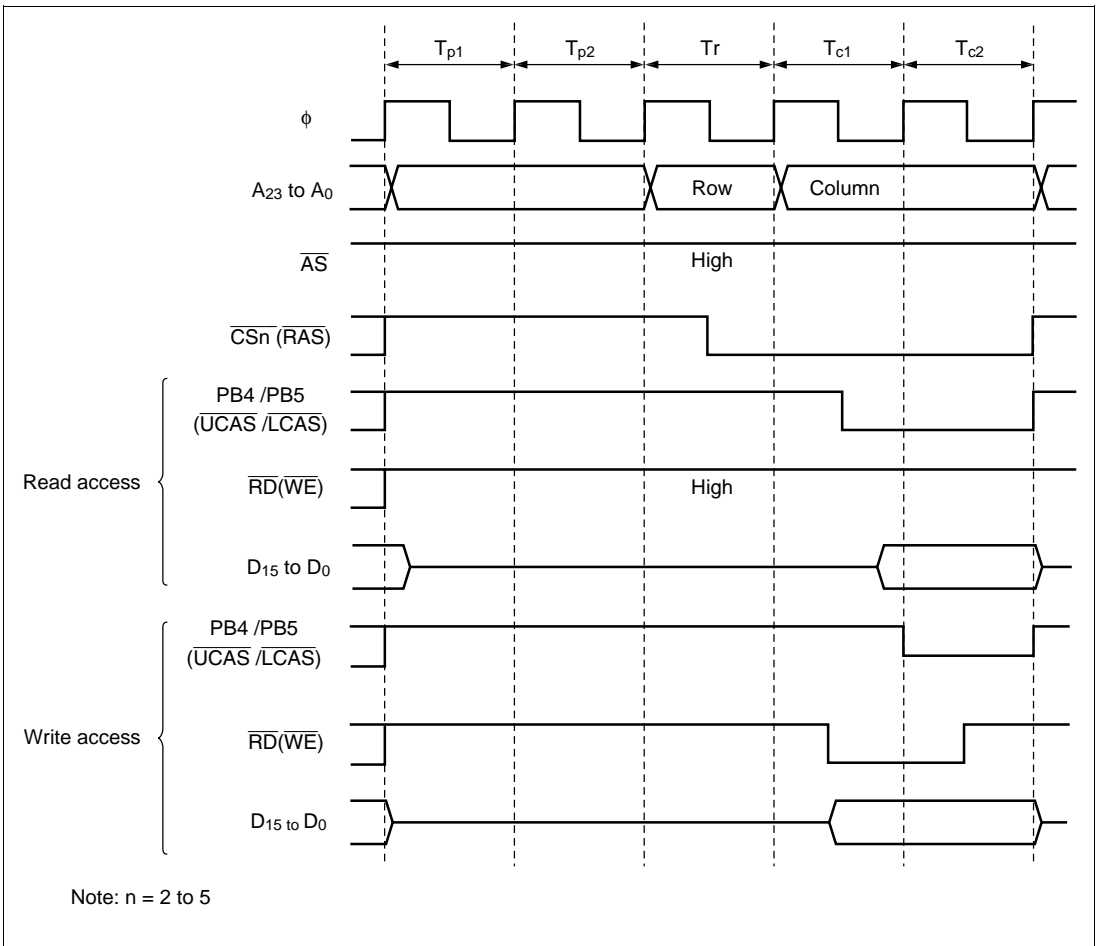

Figure 6.17 Timing with Two Precharge States (CSEL = 0 in DRCRB)

6.5.8 Wait Control

In a DRAM access cycle, wait states can be inserted (1) between the T_r state and T_{c1} state, and (2) between the T_{c1} state and T_{c2} state.

Insertion of T_{rw} Wait State between T_r and T_{c1} : One T_{rw} state can be inserted between T_r and T_{c1} by setting the RCW bit to 1 in DRCRB.

Insertion of T_w Wait State(s) between T_{c1} and T_{c2} : When the bit in ASTCR corresponding to an area designated as DRAM space is set to 1, from 0 to 3 T_w states can be inserted between the T_{c1} state and T_{c2} state by means of settings in WCRH and WCRL.

Figure 6.18 shows an example of the timing for wait state insertion.

The settings of the RCW bit in DRCRB and of ASTCR, WCRH, and WCRL do not affect refresh cycles. Wait states cannot be inserted in a DRAM space access cycle by means of the $\overline{\text{WAIT}}$ pin.

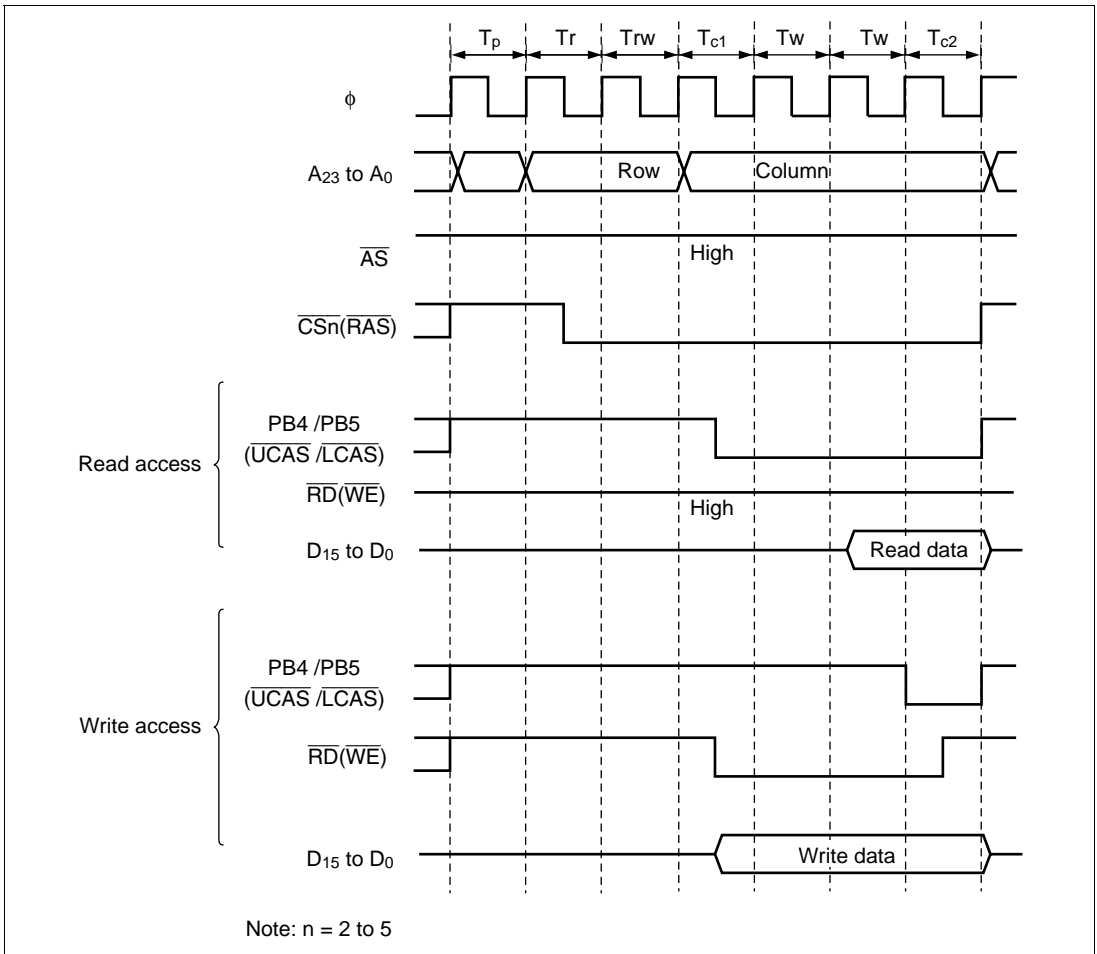

Figure 6.18 Example of Wait State Insertion Timing (CSEL = 0)

6.5.9 Byte Access Control and $\overline{\text{CAS}}$ Output Pin

When an access is made to DRAM space designated as a 16-bit-access area in ABWCR, column address strobes ($\overline{\text{UCAS}}$ and $\overline{\text{LCAS}}$) corresponding to the upper and lower halves of the external data bus are output. In the case of $\times 16$ -bit organization DRAM, the 2-CAS type can be connected.

Either PB4 and PB5, or $\overline{\text{HWR}}$ and $\overline{\text{LWR}}$, can be used as the $\overline{\text{UCAS}}$ and $\overline{\text{LCAS}}$ output pins, the selection being made with the CSEL bit in DRCRB. Table 6.8 shows the CSEL bit settings and corresponding output pin selections.

When an access is made to DRAM space designated as an 8-bit-access area in ABWCR, only \overline{UCAS} is output. When the entire DRAM space is designated as 8-bit-access space and CSEL = 0, PB5 can be used as an input/output port.

Note that \overline{RAS} down mode cannot be used when a device other than DRAM is connected to external space and \overline{HWR} and \overline{LWR} are used as write strobes. In this case, also, an idle cycle (Ti) is always inserted when an external access to other than DRAM space occurs after a DRAM space access. For details, see section 6.9, Idle Cycle.

Table 6.8 CSEL Settings and \overline{UCAS} and \overline{LCAS} Output Pins

CSEL	\overline{UCAS}	\overline{LCAS}
0	PB4	PB5
1	\overline{HWR}	\overline{LWR}

Figure 6.19 shows the control timing.

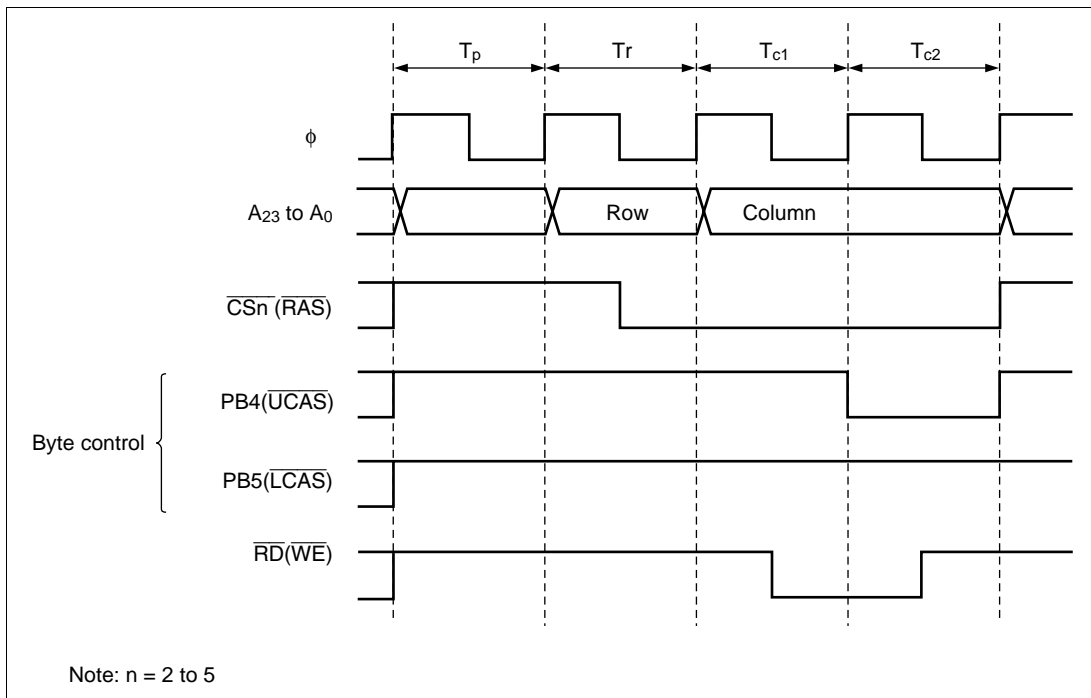

Figure 6.19 Control Timing (Upper-Byte Write Access When CSEL = 0)

6.5.10 Burst Operation

With DRAM, in addition to full access (normal access) in which data is accessed by outputting a row address for each access, a fast page mode is also provided which can be used when making a number of consecutive accesses to the same row address. This mode enables fast (burst) access of data by simply changing the column address after the row address has been output. Burst access can be selected by setting the BE bit to 1 in DRCRA.

Burst Access (Fast Page Mode) Operation Timing: Figure 6.20 shows the operation timing for burst access. When there are consecutive access cycles for DRAM space, the column address and $\overline{\text{CAS}}$ signal output cycles (two states) continue as long as the row address is the same for consecutive access cycles. In burst access, too, the bus cycle can be extended by inserting wait states between T_{c1} and T_{c2} . The wait state insertion method and timing are the same as for full access: see section 6.5.8, Wait Control, for details.

The row address used for the comparison is determined by the bus width of the relevant area set in bits MXC1 and MXC0 in BRCRB, and in ABWCR. Table 6.9 shows the compared row addresses corresponding to the various settings of bits MXC1 and MXC0, and ABWCR.

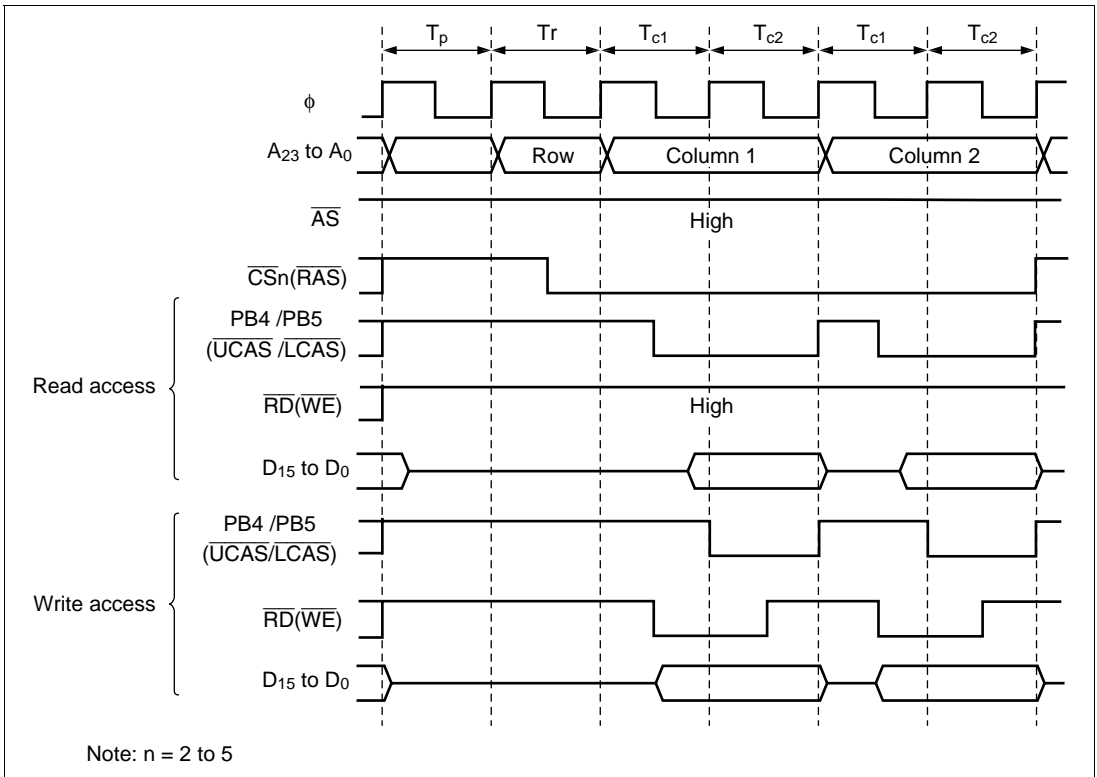

Figure 6.20 Operation Timing in Fast Page Mode

Table 6.9 Correspondence between Settings of MXC1 and MXC0 Bits and ABWCR, and Row Address Compared in Burst Access

Operating Mode	DRCRB		ABWCR		Compared Row Address
	MXC1	MXC0	ABWn	Bus Width	
Modes 1 and 2 (1-Mbyte)	0	0	0	16 bits	A19 to A9
			1	8 bits	A19 to A8
	1	0	0	16 bits	A19 to A10
			1	8 bits	A19 to A9
			1	—	—
	1	0	0	16 bits	A19 to A11
			1	8 bits	A19 to A10
Modes 3 and 4 (16-Mbyte)	0	0	0	16 bits	A23 to A9
			1	8 bits	A23 to A8
	1	0	0	16 bits	A23 to A10
			1	8 bits	A23 to A9
			1	—	—
	1	0	0	16 bits	A23 to A11
			1	8 bits	A23 to A10
1	—	—	—	Illegal setting	

Note: n = 2 to 5

RAS Down Mode and RAS Up Mode: With DRAM provided with fast page mode, as long as accesses are to the same row address, burst operation can be continued without interruption even if accesses are not consecutive by holding the $\overline{\text{RAS}}$ signal low.

- RAS Down Mode

To select RAS down mode, set the BE and RDM bits to 1 in DRCRA. If access to DRAM space is interrupted and another space is accessed, the $\overline{\text{RAS}}$ signal is held low during the access to the other space, and burst access is performed if the row address of the next DRAM space access is the same as the row address of the previous DRAM space access. Figure 6.21 shows an example of the timing in RAS down mode.

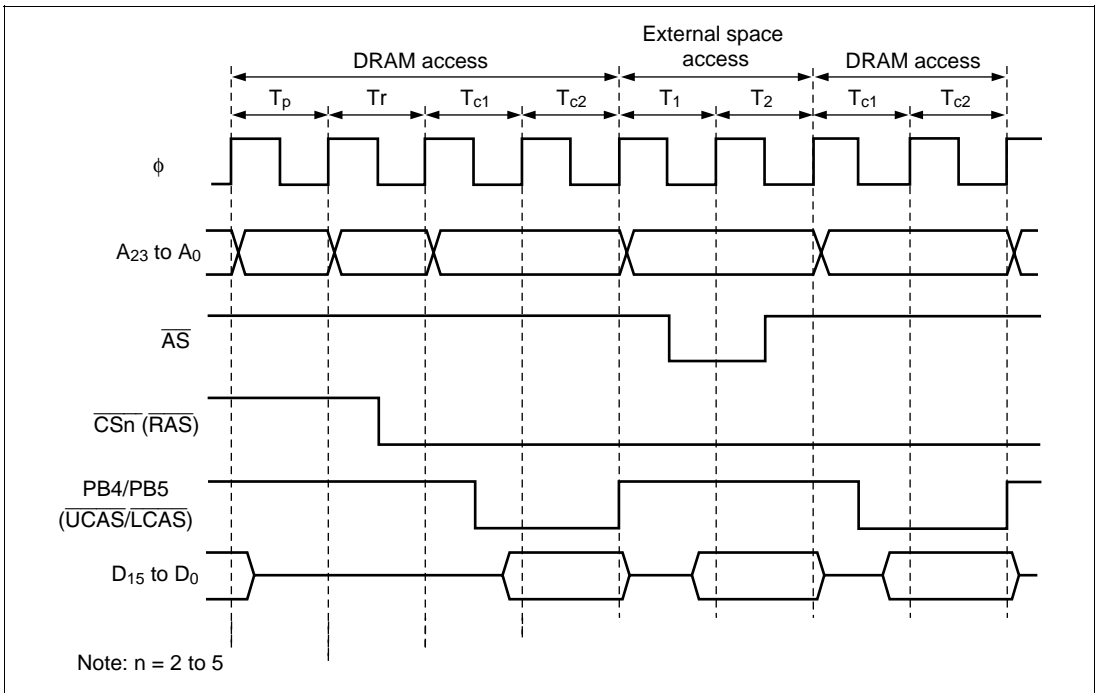
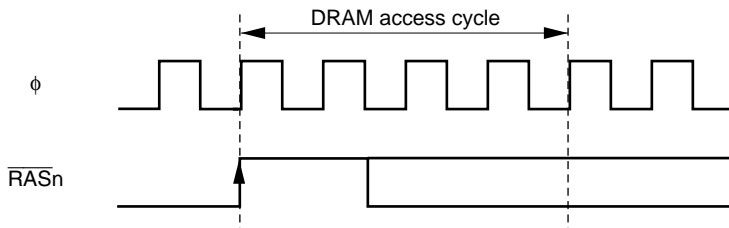

Figure 6.21 Example of Operation Timing in RAS Down Mode (CSEL = 0)

When RAS down mode is selected, the conditions for an asserted \overline{RASn} signal to return to the high level are as shown below. The timing in these cases is shown in figure 6.22.

- When DRAM space with a different row address is accessed
- Immediately before a CAS-before-RAS refresh cycle
- When the BE bit or RDM bit is cleared to 0 in DRCRA
- Immediately before release of the external bus



(a) Access to DRAM space with a different row address

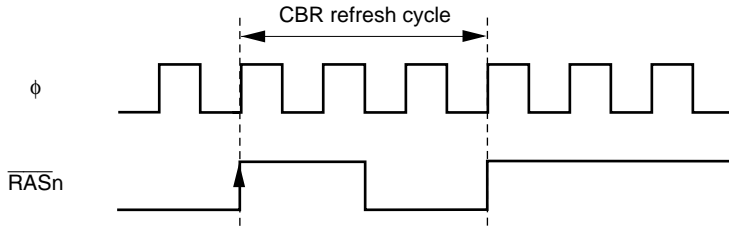

(b) CAS-before-RAS refresh cycle

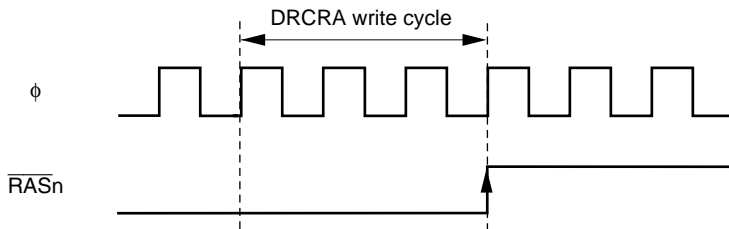

(c) BE bit or RDM bit cleared to 0 in DRCRA

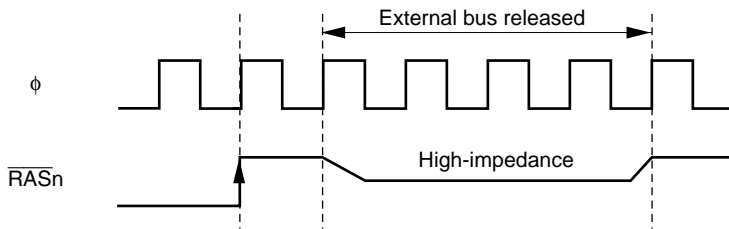

(d) External bus released

Note: n = 2 to 5

Figure 6.22 $\overline{\text{RASn}}$ Negation Timing when RAS Down Mode is Selected

When RAS down mode is selected, the CAS-before-RAS refresh function provided with this DRAM interface must always be used as the DRAM refreshing method. When a refresh operation is performed, the $\overline{\text{RAS}}$ signal goes high immediately beforehand. The refresh interval setting must be made so that the maximum DRAM $\overline{\text{RAS}}$ pulse width specification is observed.

When the self-refresh function is used, the RDM bit must be cleared to 0, and RAS up mode selected, before executing a SLEEP instruction in order to enter software standby mode. Select RAS down mode again after exiting software standby mode.

Note that RAS down mode cannot be used when $\overline{\text{HWR}}$ and $\overline{\text{LWR}}$ are selected for $\overline{\text{UCAS}}$ and $\overline{\text{LCAS}}$, a device other than DRAM is connected to external space, and $\overline{\text{HWR}}$ and $\overline{\text{LWR}}$ are used as write strobes.

- RAS Up Mode

To select RAS up mode, clear the RDM bit to 0 in DRCRA. Each time access to DRAM space is interrupted and another space is accessed, the $\overline{\text{RAS}}$ signal returns to the high level. Burst operation is only performed if DRAM space is continuous. Figure 6.23 shows an example of the timing in RAS up mode.

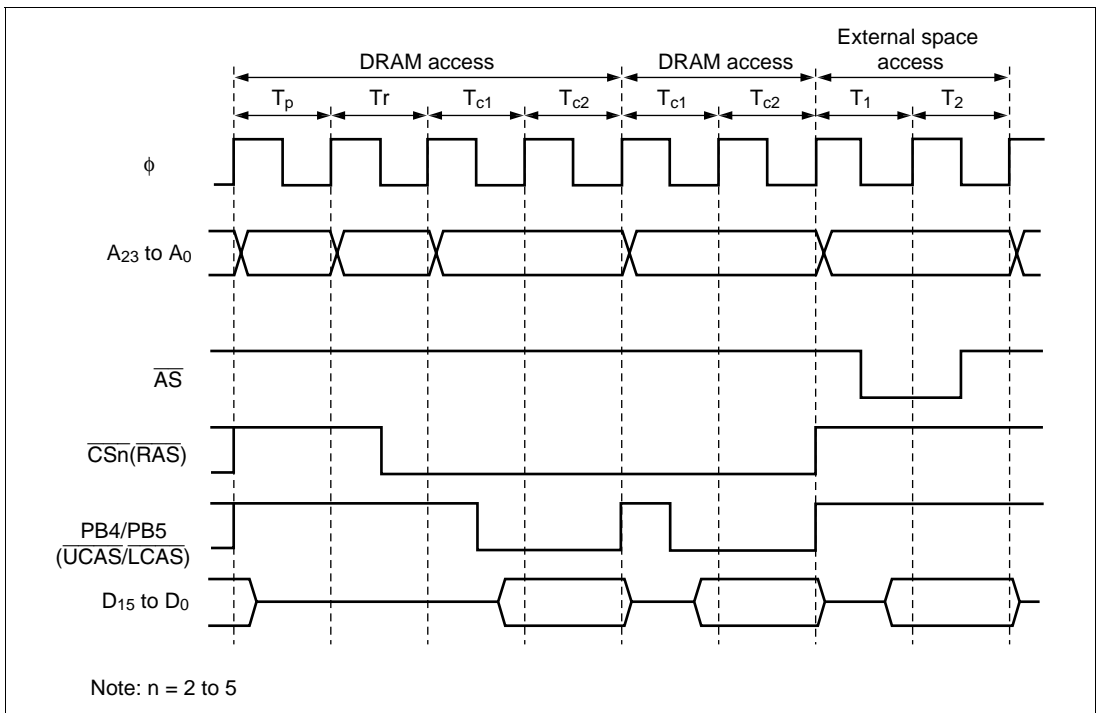

Figure 6.23 Example of Operation Timing in RAS Up Mode

6.5.11 Refresh Control

The H8/3006 and H8/3007 are provided with a CAS-before-RAS (CBR) function and self-refresh function as DRAM refresh control functions.

CAS-Before-RAS (CBR) Refreshing: To select CBR refreshing, set the RCYCE bit to 1 in DRCRB.

With CBR refreshing, RTCNT counts up using the input clock selected by bits CKS2 to CKS0 in RTMCSR, and a refresh request is generated when the count matches the value set in RTCOR (compare match). At the same time, RTCNT is reset and starts counting up again from H'00. Refreshing is thus repeated at fixed intervals determined by RTCOR and bits CKS2 to CKS0. A refresh cycle is executed after this refresh request has been accepted and the DRAM interface has acquired the bus. Set a value in bits CKS2 to CKS0 in RTCOR that will meet the refresh interval specification for the DRAM used. When RAS down mode is used, set the refresh interval so that the maximum $\overline{\text{RAS}}$ pulse width specification is met.

RTCNT starts counting up when bits CKS2 to CKS0 are set. RTCNT and RTCOR settings should therefore be completed before setting bits CKS2 to CKS0.

Also note that a repeat refresh request generated during a bus request, or a refresh request during refresh cycle execution, will be ignored.

RTCNT operation is shown in figure 6.24, compare match timing in figure 6.25, and CBR refresh timing in figures 6.26 and 6.27.

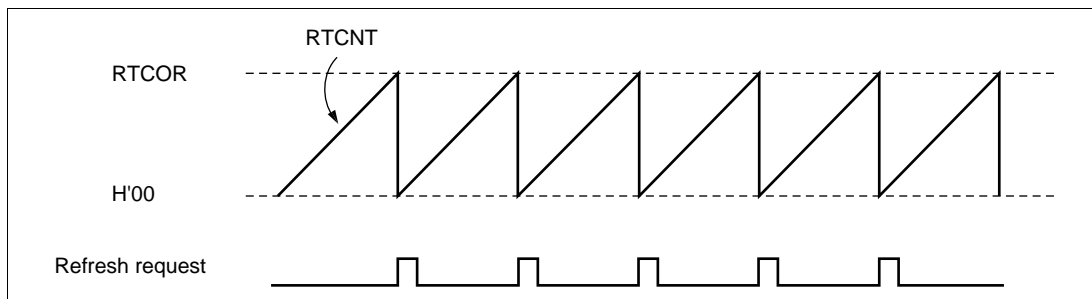

Figure 6.24 RTCNT Operation

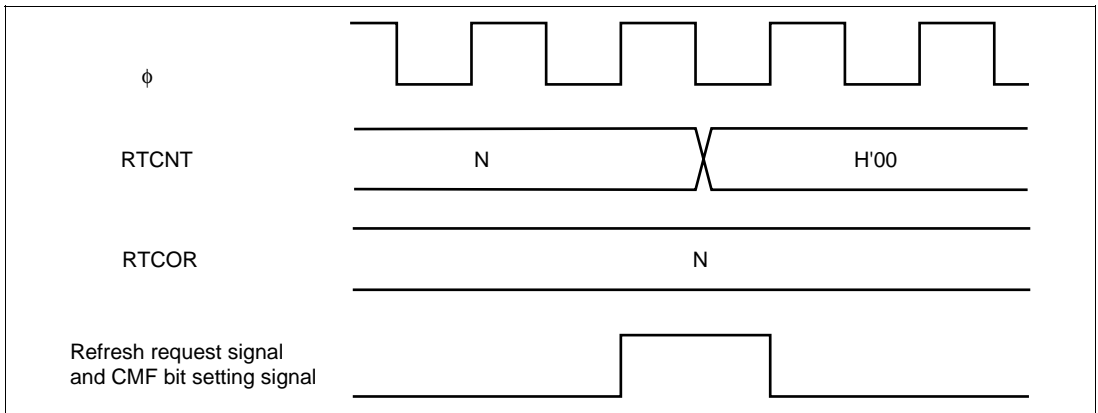

Figure 6.25 Compare Match Timing

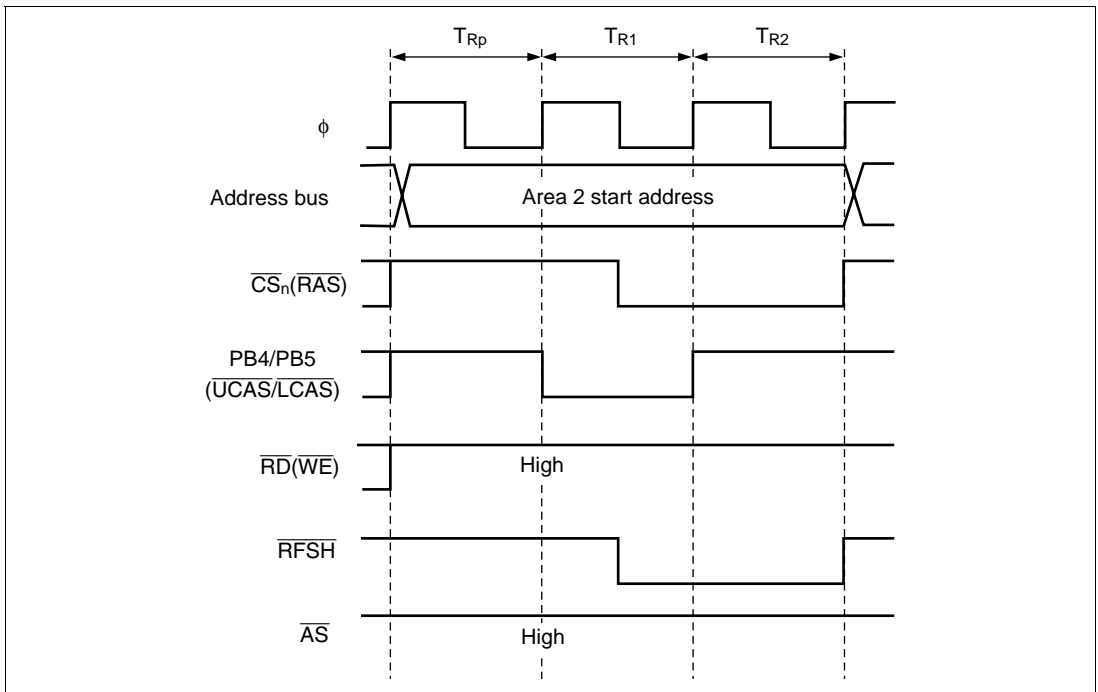

Figure 6.26 CBR Refresh Timing (CSEL = 0, TPC = 0, RLW = 0)

The basic CBS refresh cycle timing comprises three states: one RAS precharge cycle (T_{Rp}) state, and two RAS output cycle (T_{R1} , T_{R2}) states. Either one or two states can be selected for the RAS precharge cycle. When the TPC bit is set to 1 in DRCRB, \overline{RAS} signal output is delayed by one cycle. This does not affect the timing of \overline{UCAS} and \overline{LCAS} output.

Use the RLW bit in DRCRB to adjust the RAS signal width. A single refresh wait state (T_{RW}) can be inserted between the T_{R1} state and T_{R2} state by setting the RLW bit to 1.

The RLW bit setting is valid only for CBR refresh cycles, and does not affect DRAM read/write cycles. The number of states in the CBR refresh cycle is not affected by the settings in ASTCR, WCRH, or WCRL, or by the state of the $\overline{\text{WAIT}}$ pin.

Figure 6.27 shows the timing when the TPC bit and RLW bit are both set to 1.

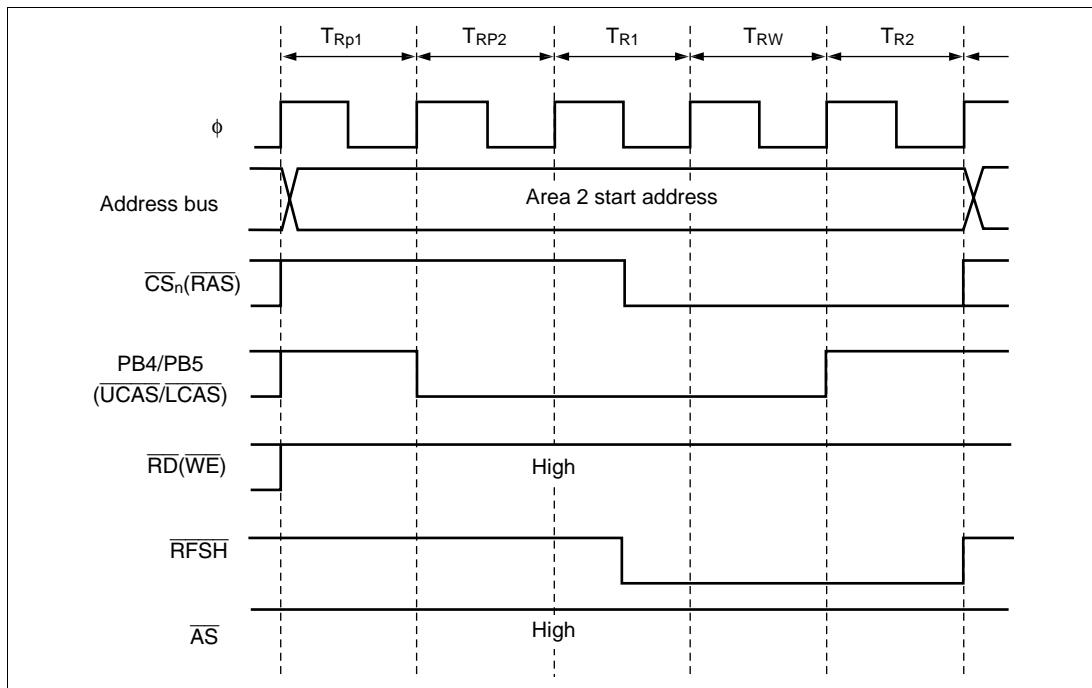

Figure 6.27 CBR Refresh Timing (CSEL = 0, TPC = 1, RLW = 1)

DRAM must be refreshed immediately after powering on in order to stabilize its internal state. When using the H8/3006 and H8/3007 CAS-before-RAS refresh function, therefore, a DRAM stabilization period should be provided by means of interrupts by another timer module, or by counting the number of times bit 7 (CMF) of RTMCSR is set, for instance, immediately after bits DRAS2 to DRAS0 have been set in DRCRA.

Self-Refreshing: A self-refresh mode (battery backup mode) is provided for DRAM as a kind of standby mode. In this mode, refresh timing and refresh addresses are generated within the DRAM. The H8/3006 and H8/3007 have a function that places the DRAM in self-refresh mode when the chip enters software standby mode.

To use the self-refresh function, set the SRFMD bit to 1 in DRCRA. When a SLEEP instruction is subsequently executed in order to enter software standby mode, the $\overline{\text{CAS}}$ and $\overline{\text{RAS}}$ signals are output and the DRAM enters self-refresh mode, as shown in figure 6.28.

When the chip exits software standby mode, $\overline{\text{CAS}}$ and $\overline{\text{RAS}}$ outputs go high.

The following conditions must be observed when the self-refresh function is used:

- When burst access is selected, RAS up mode must be selected before executing a SLEEP instruction in order to enter software standby mode. Therefore, if RAS down mode has been selected, the RDM bit in DRCRA must be cleared to 0 and RAS up mode selected before executing the SLEEP instruction. Select RAS down mode again after exiting software standby mode.
- The instruction immediately following a SLEEP instruction must not be located in an area designated as DRAM space.

The self-refresh function will not work properly unless the above conditions are observed.

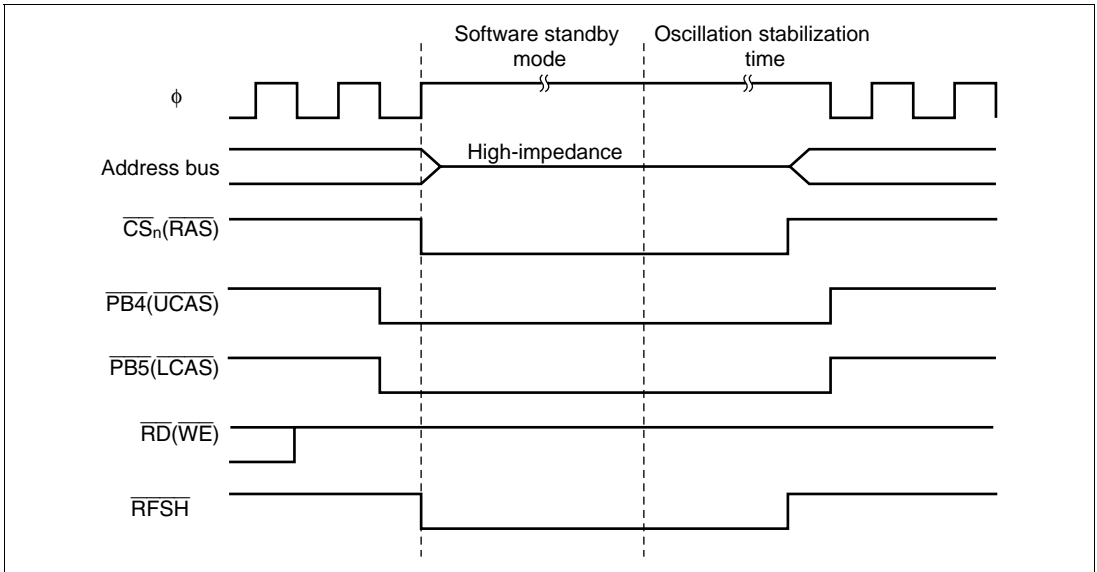

Figure 6.28 Self-Refresh Timing (CSEL = 0)

Refresh Signal ($\overline{\text{RFSH}}$): A refresh signal ($\overline{\text{RFSH}}$) that transmits a refresh cycle off-chip can be output by setting the RFSHE bit to 1 in DRCRA. $\overline{\text{RFSH}}$ output timing is shown in figures 6.26, 6.27, and 6.28.

6.5.12 Examples of Use

Examples of DRAM connection and program setup procedures are shown below. When the DRAM interface is used, check the DRAM device characteristics and choose the most appropriate method of use for that device.

Connection Examples

- Figure 6.29 shows typical interconnections when using two 2-CAS type 16-Mbit DRAMs using a $\times 16$ -bit organization, and the corresponding address map. The DRAMs used in this example are of the 10-bit row address \times 10-bit column address type. Up to four DRAMs can be connected by designating areas 2 to 5 as DRAM space.

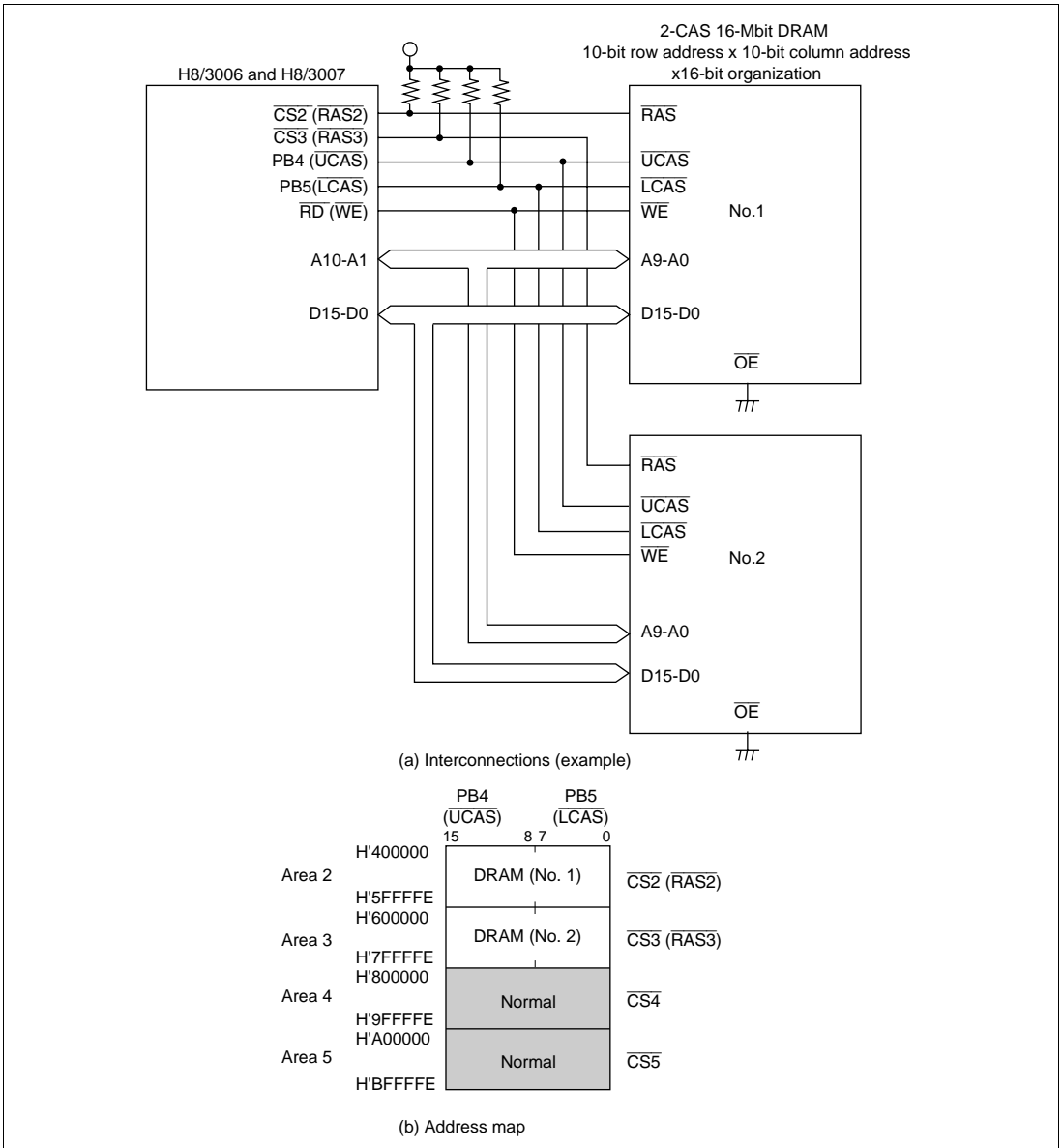

Figure 6.29 Interconnections and Address Map for 2-CAS 16-Mbit DRAMs with $\times 16$ -Bit Organization

- Figure 6.30 shows typical interconnections when using two 16-Mbit DRAMs using a $\times 8$ -bit organization, and the corresponding address map. The DRAMs used in this example are of the 11-bit row address \times 10-bit column address type. The $\overline{CS2}$ pin is used as a common \overline{RAS} output pin for area 2 and area 3. When the DRAM address space spans a number of contiguous areas, as in this example, the appropriate setting of bits DRAS2 to DRAS0 enables a single \overline{CS} pin to be used as the common \overline{RAS} output pin for a number of areas, and makes it possible to directly connect large-capacity DRAM with address space that spans a maximum of four areas. Any unused \overline{CS} pins (in this example, the $\overline{CS3}$ pin) can be used as input/output ports.

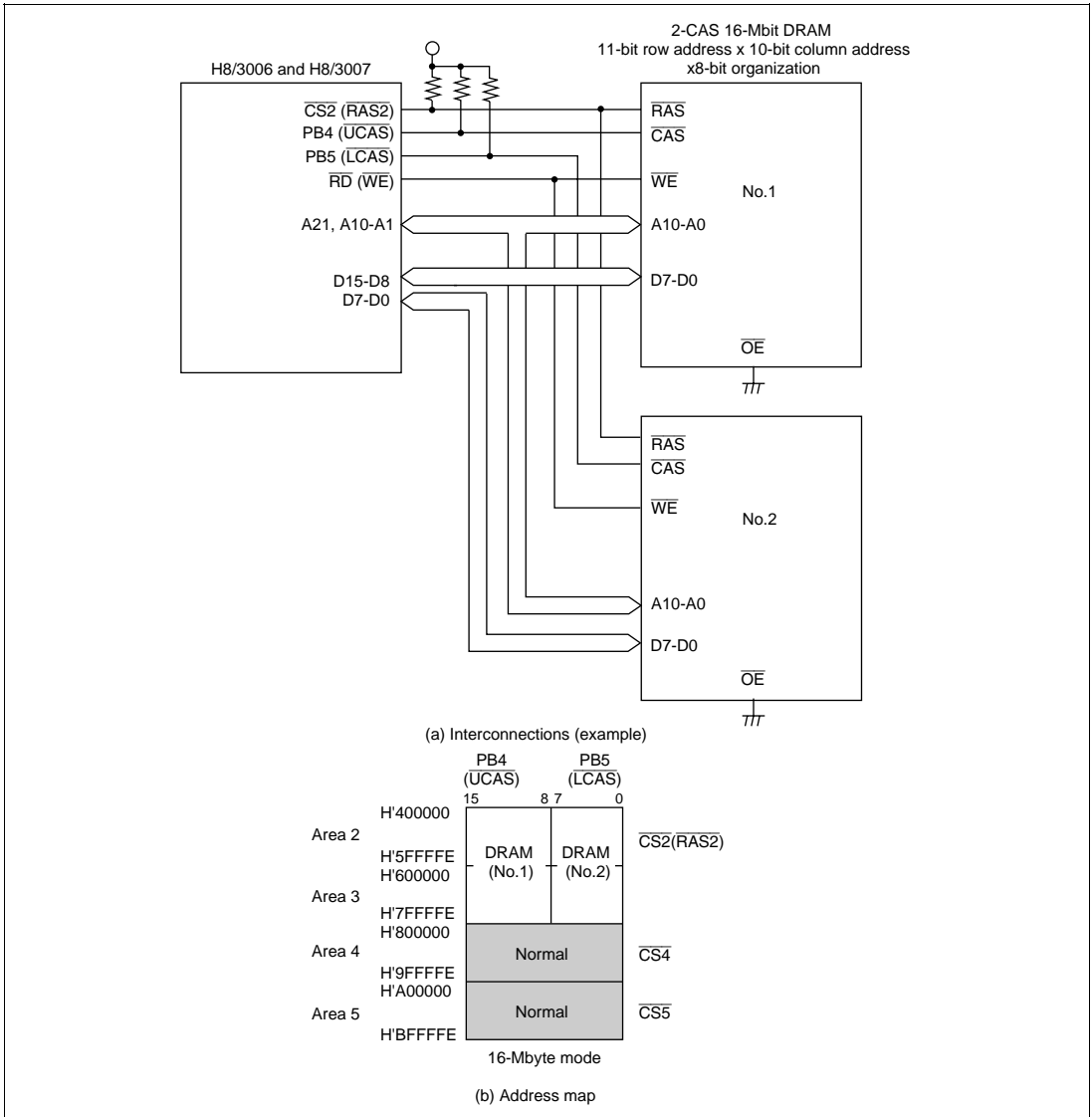

Figure 6.30 Interconnections and Address Map for 16-Mbit DRAMs with $\times 8$ -Bit Organization

- Figure 6.31 shows typical interconnections when using two 4-Mbit DRAMs, and the corresponding address map. The DRAMs used in this example are of the 9-bit row address \times 9-bit column address type. In this example, upper address decoding allows multiple DRAMs to be connected to a single area. The $\overline{\text{RFSH}}$ pin is used in this case, since both DRAMs must be refreshed simultaneously. However, note that RAS down mode cannot be used in this interconnection example.

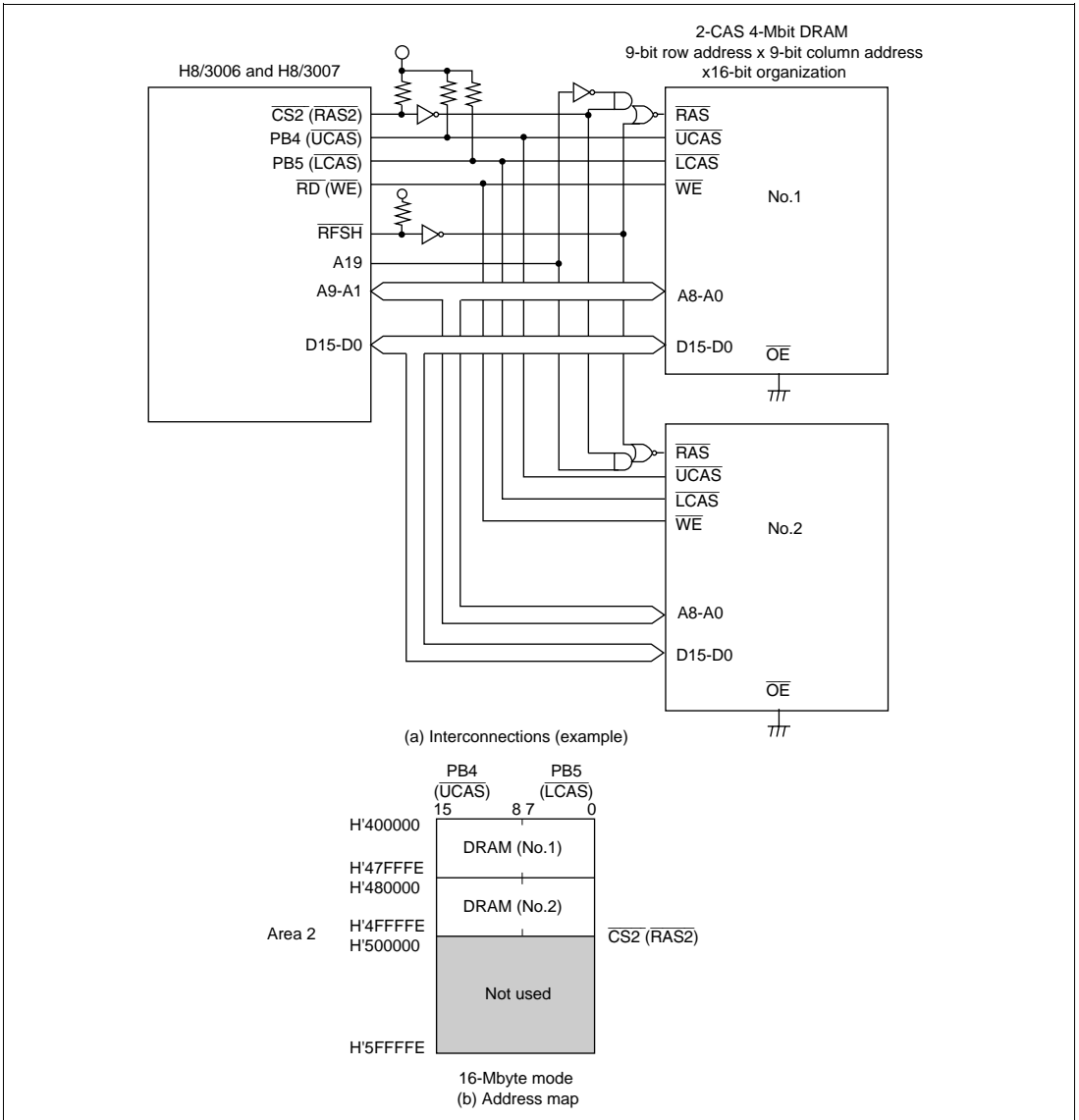

Figure 6.31 Interconnections and Address Map for 2-CAS 4-Mbit DRAMs with \times 16-Bit Organization

Example of Program Setup Procedure: Figure 6.32 shows an example of the program setup procedure.

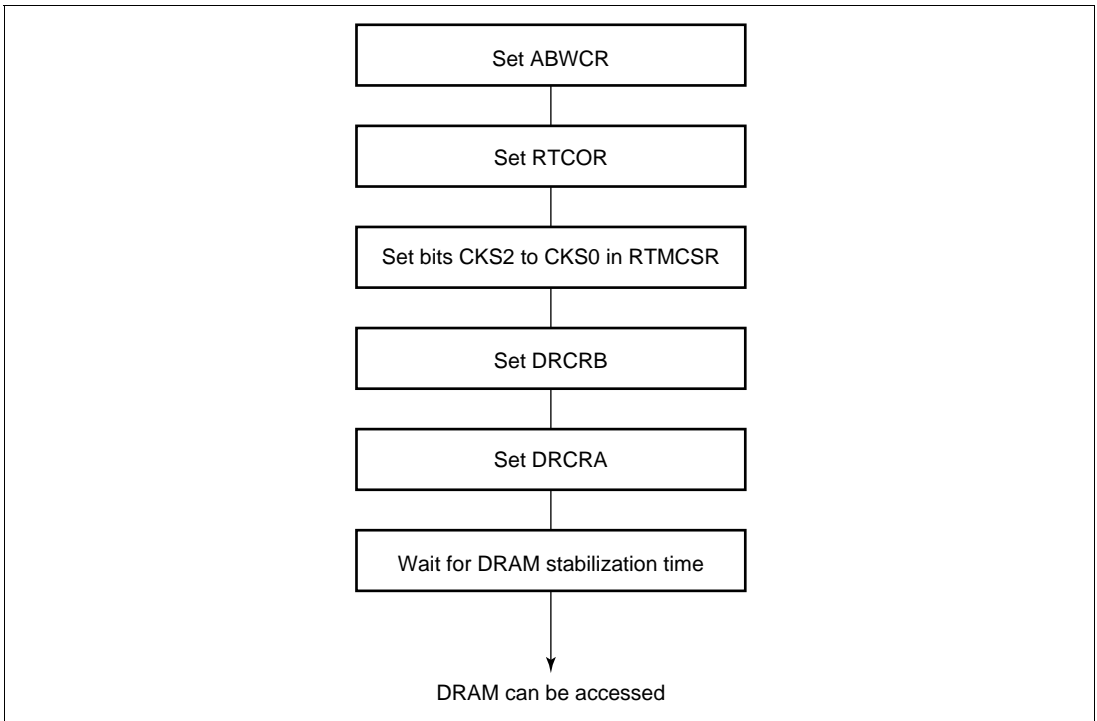

Figure 6.32 Example of Setup Procedure when Using DRAM Interface

6.5.13 Usage Notes

Note the following points when using the DRAM refresh function.

- Refresh cycles will not be executed when the external bus released state, software standby mode, or a bus cycle is extended by means of wait state insertion. Refreshing must therefore be performed by other means in these cases.
- If a refresh request is generated internally while the external bus is released, the first request is retained and a single refresh cycle will be executed after the bus-released state is cleared. Figure 6.33 shows the bus cycle in this case.
- When a bus cycle is extended by means of wait state insertion, the first request is retained in the same way as when the external bus has been released.
- In the event of contention with a bus request from an external bus master when a transition is made to software standby mode, the $\overline{\text{BACK}}$ and strobe states may be indeterminate after the transition to software standby mode (see figure 6.34).

When software standby mode is used, the BRLE bit should be cleared to 0 in BRCR before executing the SLEEP instruction.

Similar contention in a transition to self-refresh mode may prevent dependable strobe waveform output. This can also be avoided by clearing the BRLW bit to 0 in BRCR.

- Immediately after self-refreshing is cleared, external bus release is possible during a given period until the start of a CPU cycle. Attention must be paid to the $\overline{\text{RAS}}$ state to ensure that the specification for the $\overline{\text{RAS}}$ precharge time immediately after self-refreshing is met.

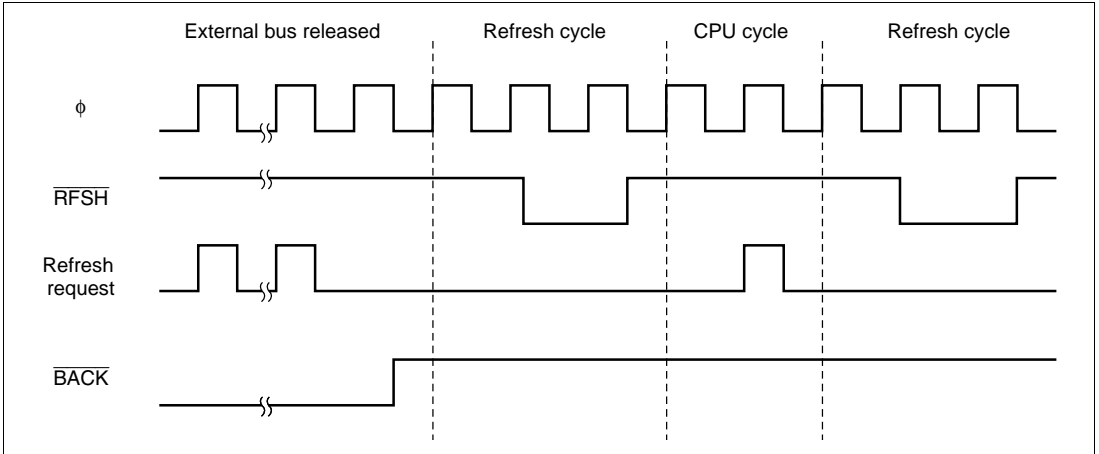

Figure 6.33 Bus-Released State and Refresh Cycles

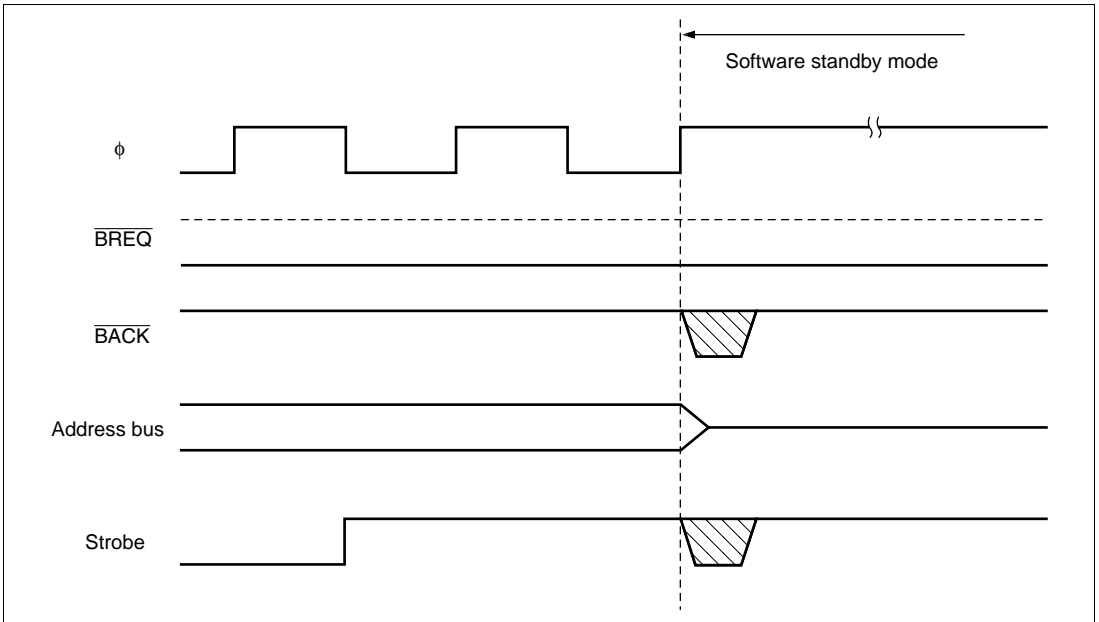

Figure 6.34 Bus-Released State and Software Standby Mode

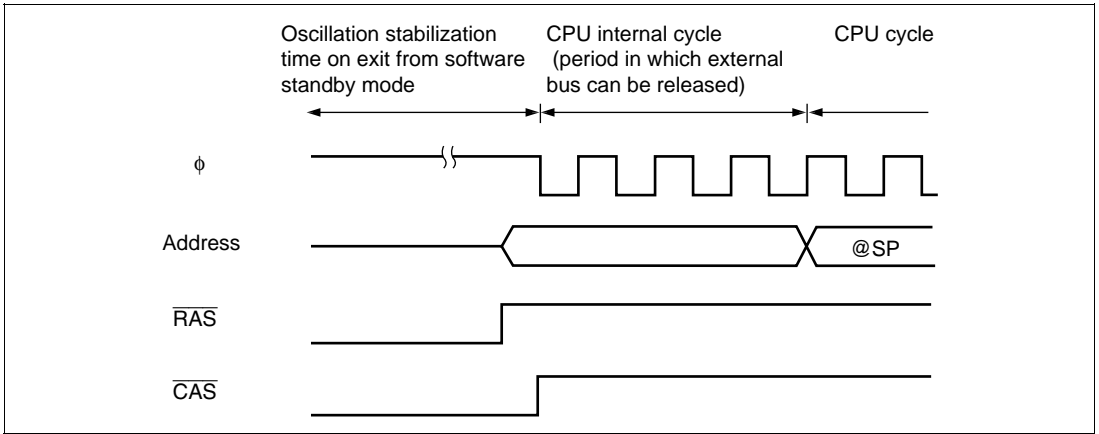

Figure 6.35 Self-Refresh Clearing

6.6 Interval Timer

6.6.1 Operation

When DRAM is not connected to the H8/3006 and H8/3007 chip, the refresh timer can be used as an interval timer by clearing bits DRAS2 to DRAS0 in DRCRA to 0. After setting RTCOR, selection a clock source with bits CKS2 to CKS0 in RTMCSR, and set the CMIE bit to 1.

Timing of Setting of Compare Match Flag and Clearing by Compare Match: The CMF flag in RTMCSR is set to 1 by a compare match output when the RTCOR and RTCNT values match. The compare match signal is generated in the last state in which the values match (when RTCNT is updated from the matching value to a new value). Accordingly, when RTCNT and RTCOR match, the compare match signal is not generated until the next counter clock pulse. Figure 6.36 shows the timing.

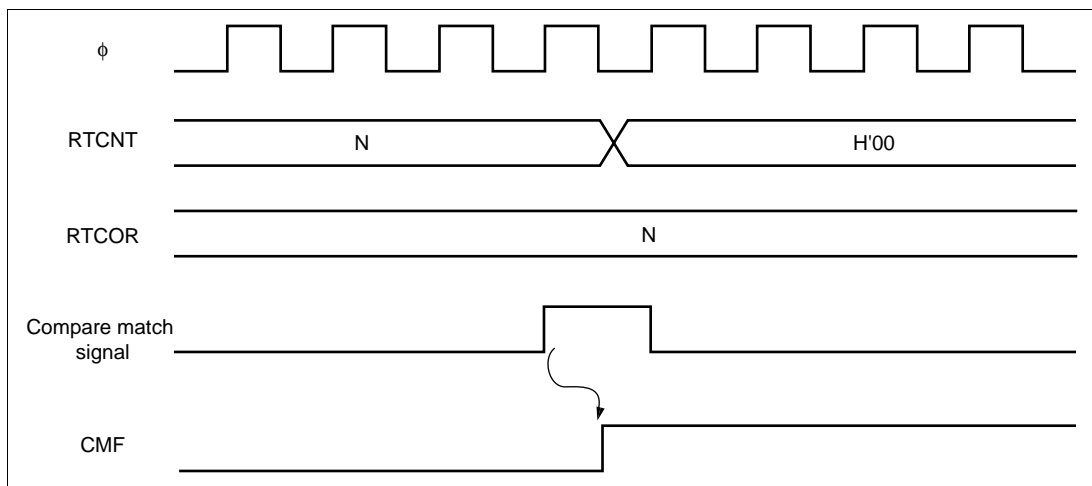

Figure 6.36 Timing of CMF Flag Setting

Operation in Power-Down State: The interval timer operates in sleep mode. It does not operate in hardware standby mode. In software standby mode, RTCNT and RTMCSR bits 7 and 6 are initialized, but RTMCSR bits 5 to 3 and RTCOR retain their settings prior to the transition to software standby mode.

Contention between RTCNT Write and Counter Clear: If a counter clear signal occurs in the T_3 state of an RTCNT write cycle, clearing of the counter takes priority and the write is not performed. See Figure 6.37.

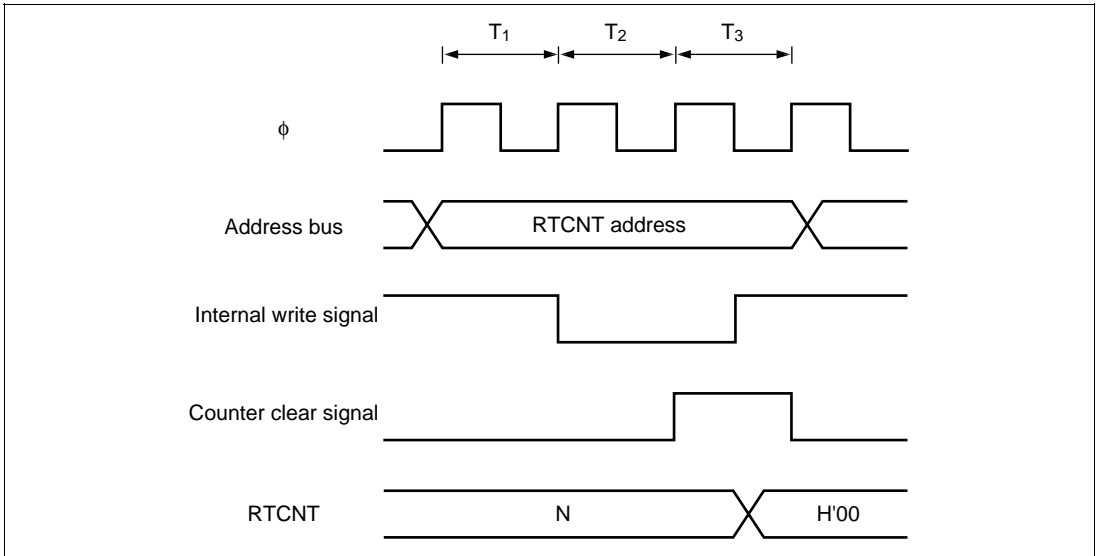

Figure 6.37 Contention between RTCNT Write and Clear

Contention between RTCNT Write and Increment: If an increment pulse occurs in the T₃ state of an RTCNT write cycle, writing takes priority and RTCNT is not incremented. See Figure 6.38.

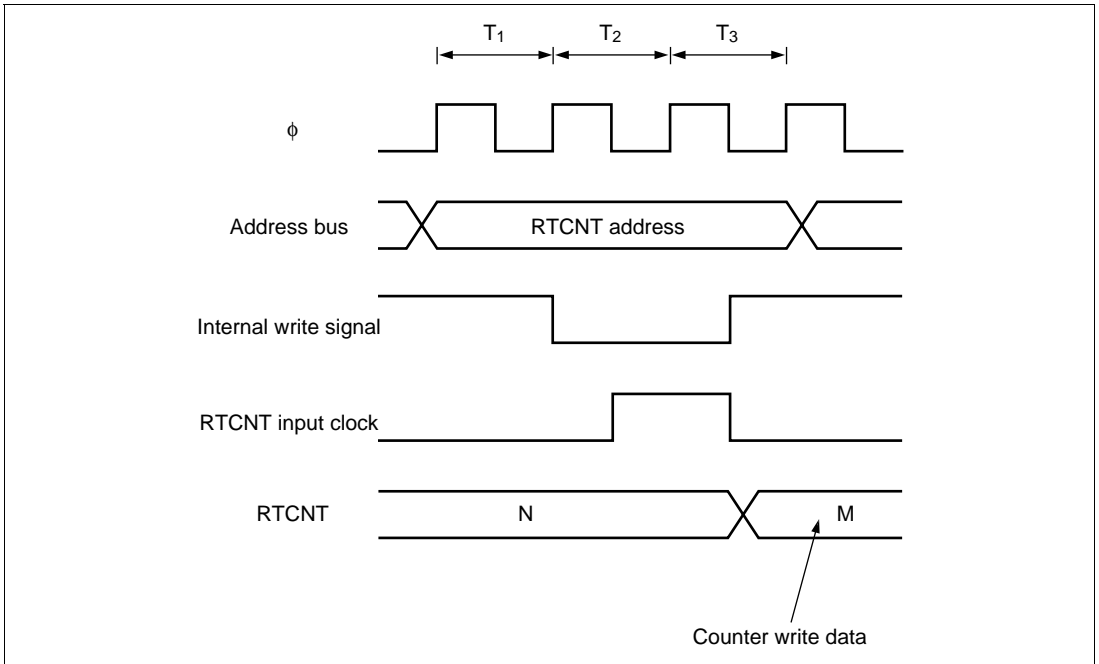

Figure 6.38 Contention between RTCNT Write and Increment

Contention between RTCOR Write and Compare Match: If a compare match occurs in the T_3 state of an RTCOR write cycle, writing takes priority and the compare match signal is inhibited. See Figure 6.39.

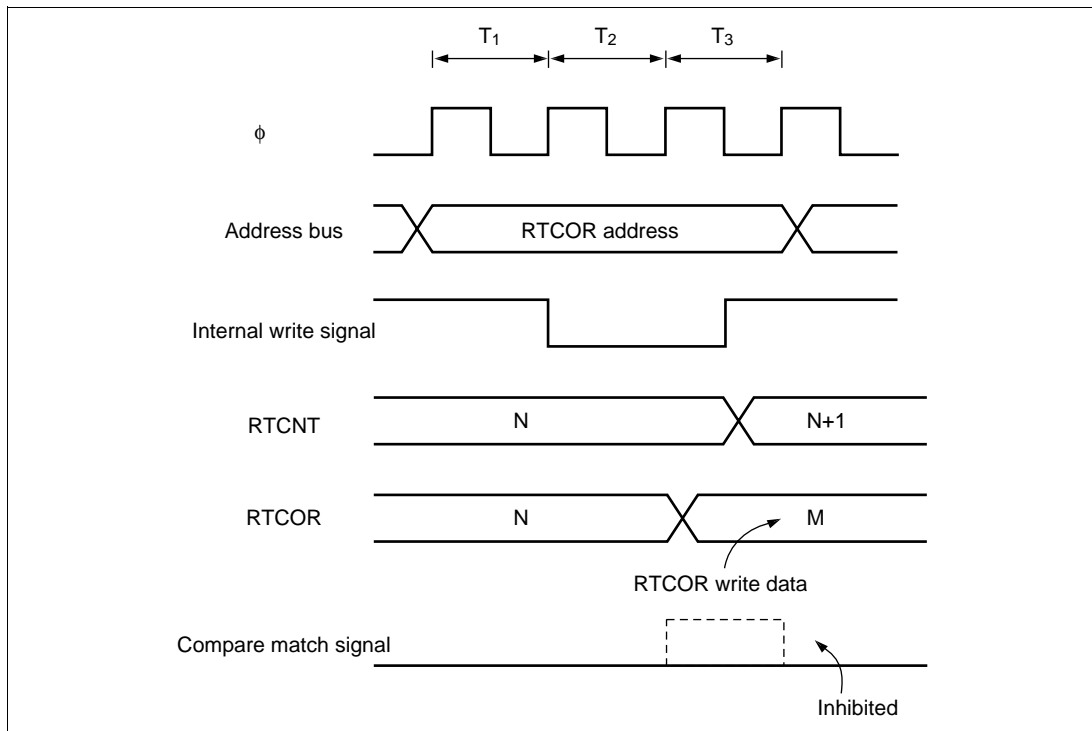
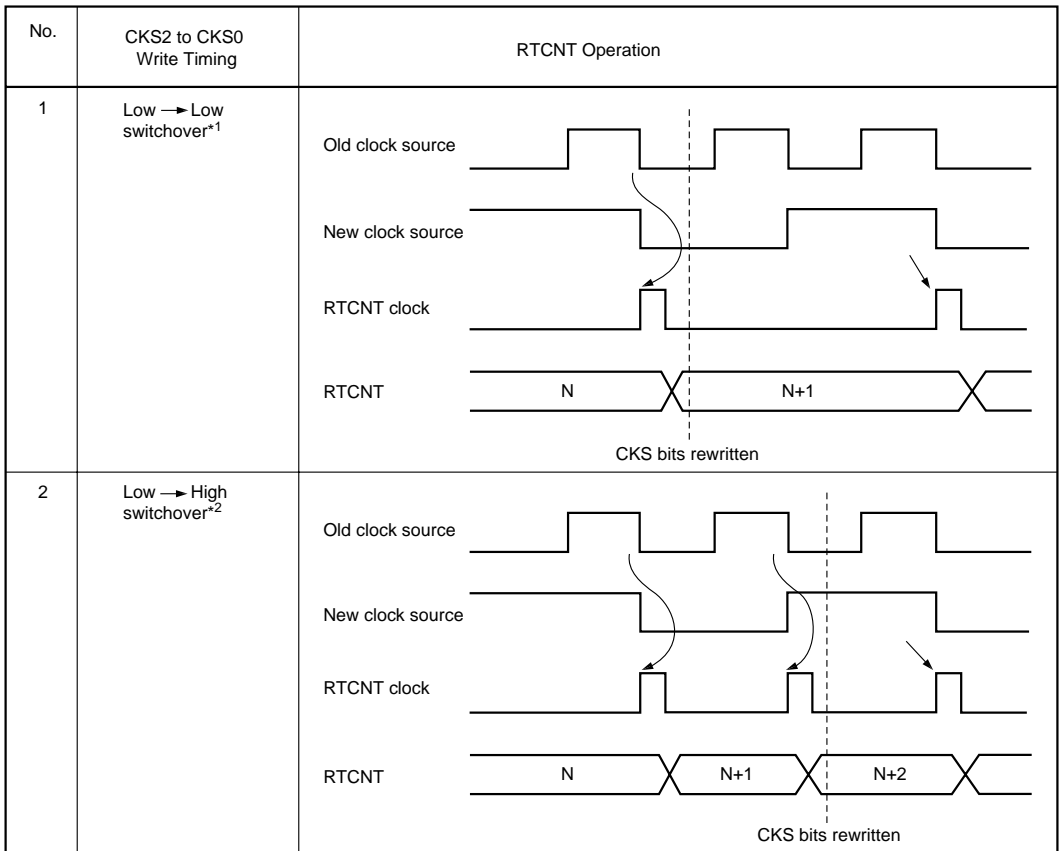

Figure 6.39 Contention between RTCOR Write and Compare Match

RTCNT Operation at Internal Clock Source Switchover: Switching internal clock sources may cause RTCNT to increment, depending on the switchover timing. Table 6.10 shows the relation between the time of the switchover (by writing to bits CKS2 to CKS0) and the operation of RTCNT.

The RTCNT input clock is generated from the internal clock source by detecting the falling edge of the internal clock. If a switchover is made from a high clock source to a low clock source, as in case No. 3 in table 6.10, the switchover will be regarded as a falling edge, an RTCNT clock pulse will be generated, and RTCNT will be incremented.

Table 6.10 Internal Clock Switchover and RTCNT Operation



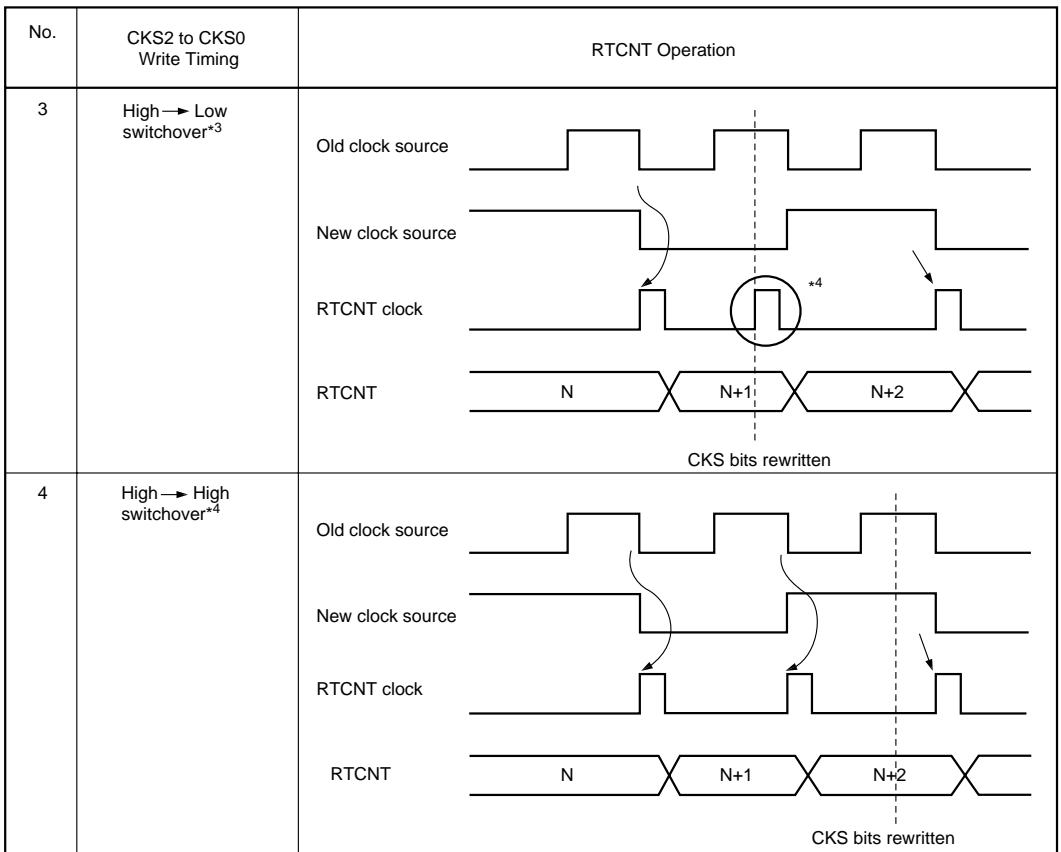

- Notes:
1. Including switchovers from a low clock source to the halted state, and from the halted state to a low clock source.
 2. Including switchover from the halted state to a high clock source.
 3. Including switchover from a high clock source to the halted state.
 4. The switchover is regarded as a falling edge, causing RTCNT to increment.

6.7 Interrupt Sources

Compare match interrupts (CMI) can be generated when the refresh timer is used as an interval timer. Compare match interrupt requests are masked/unmasked with the CMIE bit in RTMCSR.

6.8 Burst ROM Interface

6.8.1 Overview

With the H8/3006 and H8/3007, external space area 0 can be designated as burst ROM space, and burst ROM space interfacing can be performed. The burst ROM interface enables ROM with burst access capability to be accessed at high speed. Area 0 is designated as burst ROM space by means of the BROME bit in BCR.

Continuous burst access of a maximum of four or eight words can be performed on external space area 0. Two or three states can be selected for burst access.

6.8.2 Basic Timing

The number of states in the initial cycle (full access) and a burst cycle of the burst ROM interface is determined by the setting of the AST0 bit in ASTCR. When the AST0 bit is set to 1, wait states can also be inserted in the initial cycle. Wait states cannot be inserted in a burst cycle.

Burst access of up to four words is performed when the BRSTS0 bit is cleared to 0 in BCR, and burst access of up to eight words when the BRSTS0 bit is set to 1. The number of burst access states is two when the BRSTS1 bit is cleared to 0, and three when the BRSTS1 bit is set to 1.

The basic access timing for burst ROM space is shown in figure 6.40.

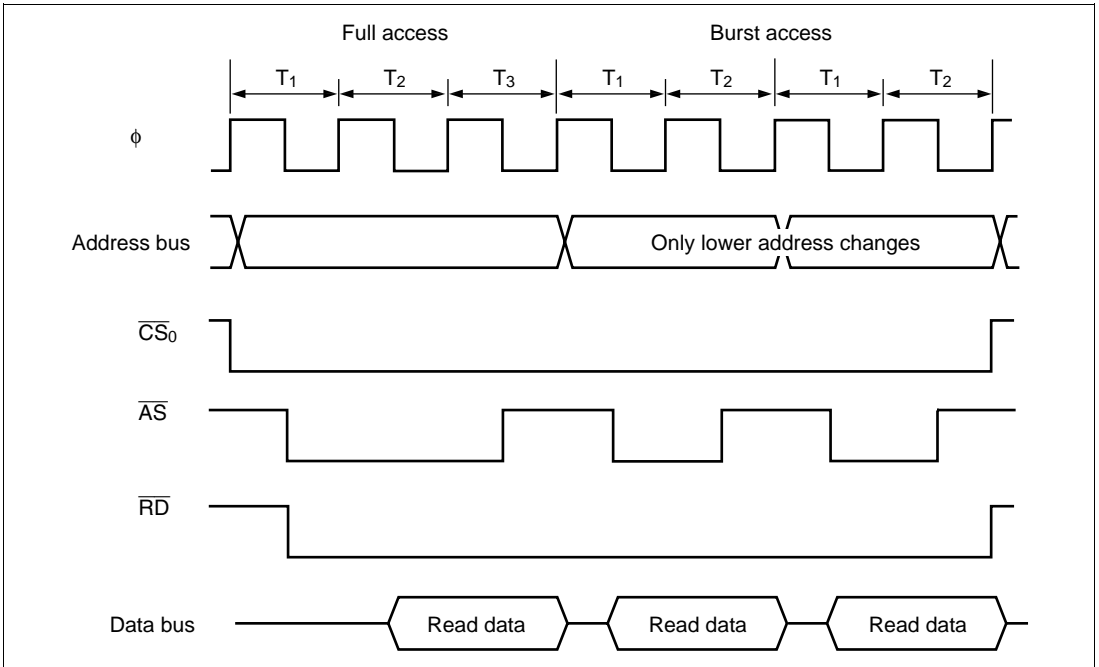

Figure 6.40 Example of Burst ROM Access Timing

6.8.3 Wait Control

As with the basic bus interface, either program wait insertion or pin wait insertion using the \overline{WAIT} pin can be used in the initial cycle (full access) of the burst ROM interface.

Wait states cannot be inserted in a burst cycle.

6.9 Idle Cycle

6.9.1 Operation

When the H8/3006 and H8/3007 chip accesses external space, it can insert a 1-state idle cycle (T_i) between bus cycles in the following cases: (1) when read accesses between different areas occur consecutively, (2) when a write cycle occurs immediately after a read cycle, and (3) when external address space other than DRAM space is accessed immediately after a DRAM space access. By inserting an idle cycle it is possible, for example, to avoid data collisions between ROM, which has a long output floating time, and high-speed memory, I/O interfaces, and so on.

The ICIS1 and ICIS0 bits in BCR both have an initial value of 1, so that an idle cycle is inserted in the initial state. If there are no data collisions, the ICIS bits can be cleared.

Consecutive Reads between Different Areas: If consecutive reads between different areas occur while the ICIS1 bit is set to 1 in BCR, an idle cycle is inserted at the start of the second read cycle.

Figure 6.41 shows an example of the operation in this case. In this example, bus cycle A is a read cycle from ROM with a long output floating time, and bus cycle B is a read cycle from SRAM, each being located in a different area. In (a), an idle cycle is not inserted, and a collision occurs in cycle B between the read data from ROM and that from SRAM. In (b), an idle cycle is inserted, and a data collision is prevented.

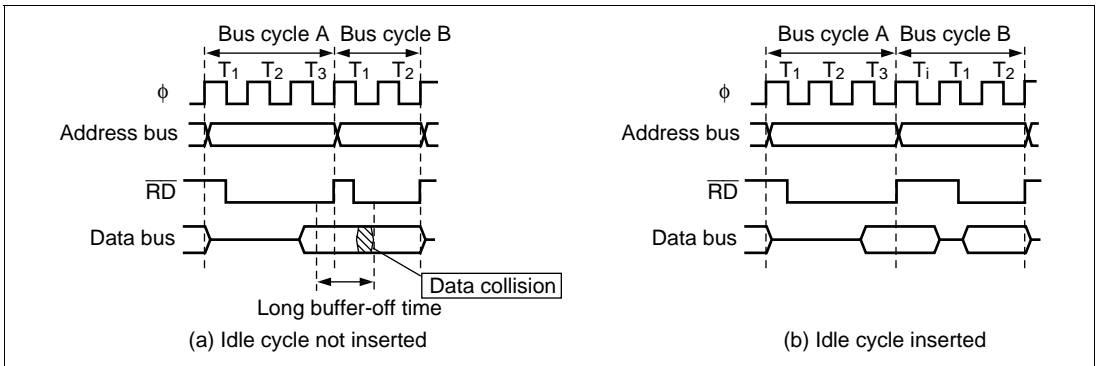

Figure 6.41 Example of Idle Cycle Operation (1) (ICIS1 = 1)

Write after Read: If an external write occurs after an external read while the ICIS0 bit is set to 1 in BCR, an idle cycle is inserted at the start of the write cycle.

Figure 6.42 shows an example of the operation in this case. In this example, bus cycle A is a read cycle from ROM with a long output floating time, and bus cycle B is a CPU write cycle.

In (a), an idle cycle is not inserted, and a collision occurs in cycle B between the read data from ROM and the CPU write data. In (b), an idle cycle is inserted, and a data collision is prevented.

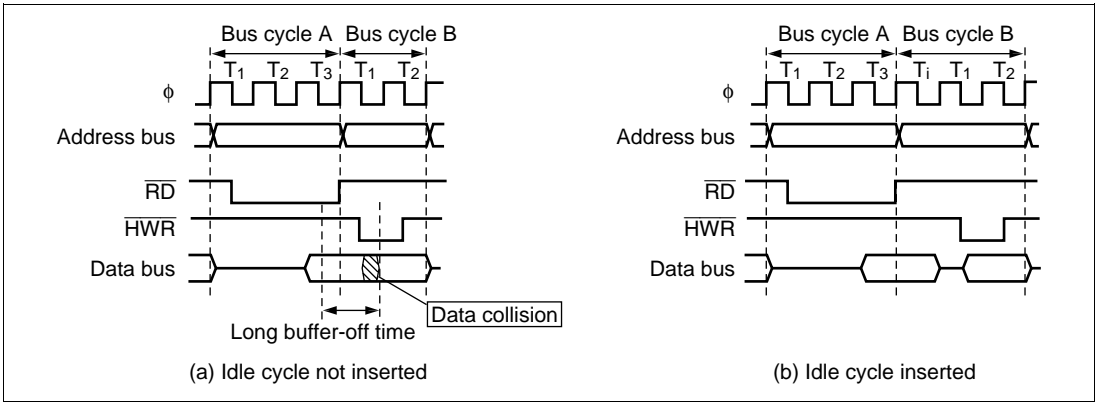

Figure 6.42 Example of Idle Cycle Operation (2) (ICIS0 = 1)

External Address Space Access Immediately after DRAM Space Access: If a DRAM space access is followed by a non-DRAM external access when $\overline{\text{HWR}}$ and $\overline{\text{LWR}}$ have been selected as the $\overline{\text{UCAS}}$ and $\overline{\text{LCAS}}$ output pins by means of the CSEL bit in DRCRB, a T_i cycle is inserted regardless of the settings of bits ICIS0 and ICIS1 in BCR. Figure 6.43 shows an example of the operation.

This is done to prevent simultaneous changing of the $\overline{\text{HWR}}$ and $\overline{\text{LWR}}$ signals used as $\overline{\text{UCAS}}$ and $\overline{\text{LCAS}}$ in DRAM space and $\overline{\text{CSn}}$ for the space in the next cycle, and so avoid an erroneous write to the external device in the next cycle.

A T_i cycle is not inserted when PB4 and PB5 have been selected as the $\overline{\text{UCAS}}$ and $\overline{\text{LCAS}}$ output pins.

In the case of consecutive DRAM space access precharge cycles (T_p), the ICIS0 and ICIS1 bit settings are invalid. In the case of consecutive reads between different areas, for example, if the second access is a DRAM access, only a T_p cycle is inserted, and a T_i cycle is not. The timing in this case is shown in figure 6.44.

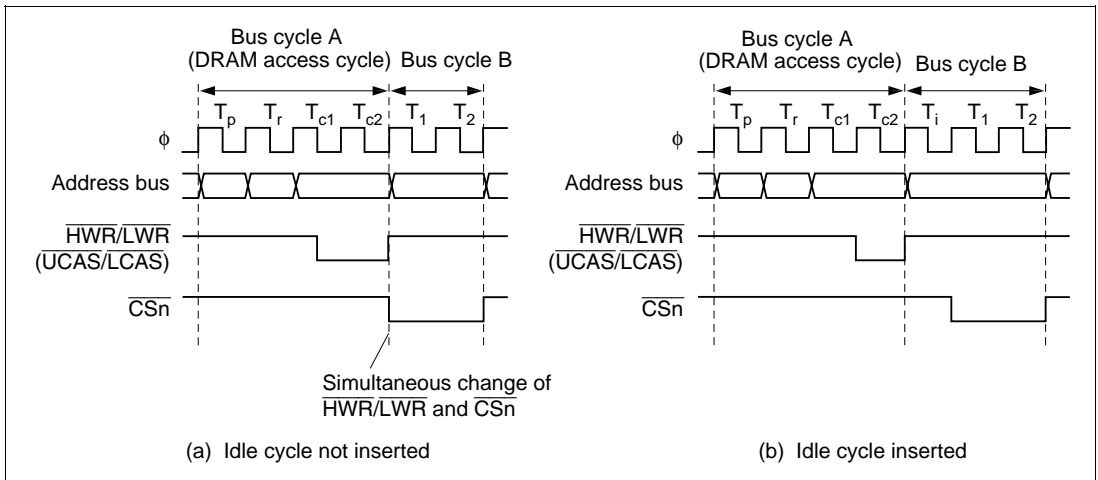

Figure 6.43 Example of Idle Cycle Operation (3) ($\overline{\text{HWR/LWR}}$ Used as $\overline{\text{UCAS/LCAS}}$)

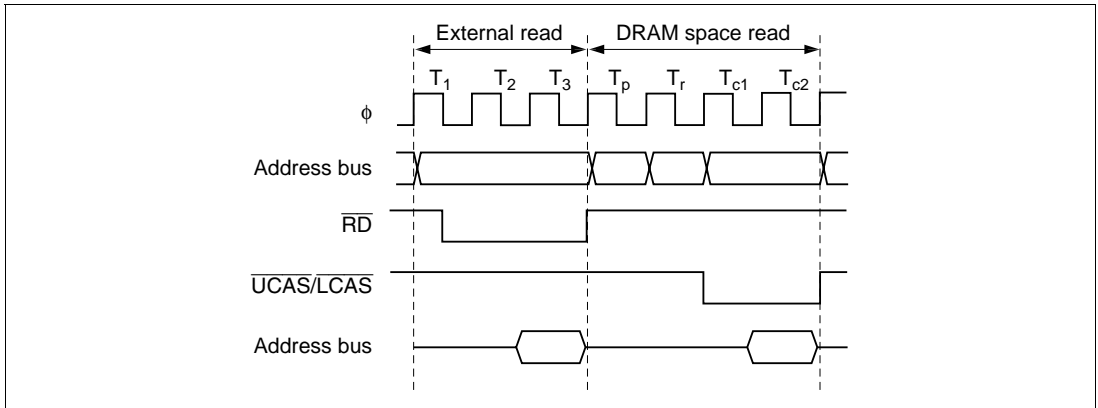

Figure 6.44 Example of Idle Cycle Operation (4) (Consecutive Precharge Cycles)

Usage Notes: When non-insertion of idle cycles is set, the rise (negation) of $\overline{\text{RD}}$ and the fall (assertion) of $\overline{\text{CSn}}$ may occur simultaneously. An example of the operation is shown in figure 6.45.

If consecutive reads between different external areas occur while the ICIS1 bit is cleared to 0 in BCR, or if a write cycle to a different external area occurs after an external read while the ICIS0 bit is cleared to 0, the $\overline{\text{RD}}$ negation in the first read cycle and the $\overline{\text{CSn}}$ assertion in the following bus cycle will occur simultaneously. Therefore, depending on the output delay time of each signal, it is possible that the low-level output of $\overline{\text{RD}}$ in the preceding read cycle and the low-level output of $\overline{\text{CSn}}$ in the following bus cycle will overlap.

A setting whereby idle cycle insertion is not performed can be made only when $\overline{\text{RD}}$ and $\overline{\text{CSn}}$ do not change simultaneously, or when it does not matter if they do.

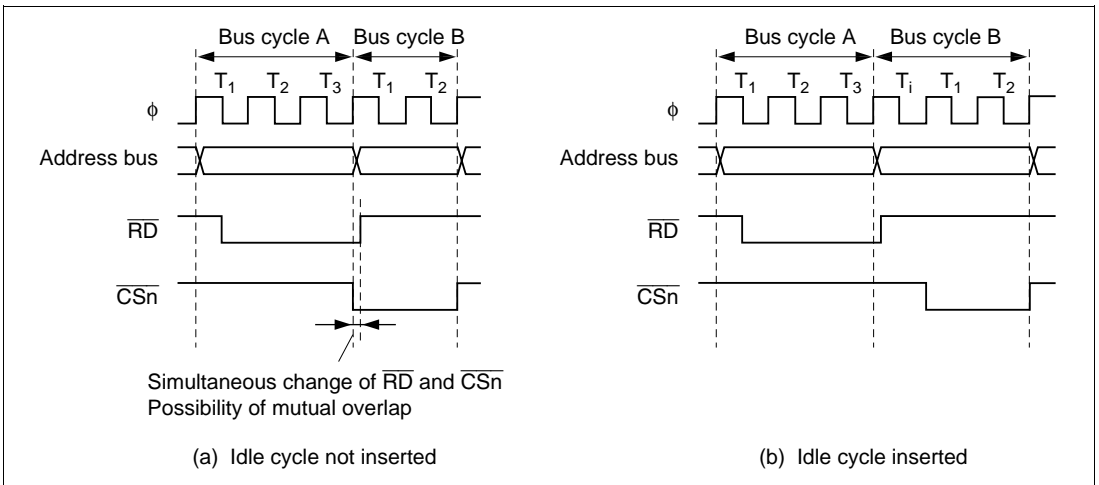

Figure 6.45 Example of Idle Cycle Operation (5)

6.9.2 Pin States in Idle Cycle

Table 6.11 shows the pin states in an idle cycle.

Table 6.11 Pin States in Idle Cycle

Pins	Pin State
A_{23} to A_0	Next cycle address value
D_{15} to D_0	High impedance
\overline{CS}_n	High*
\overline{UCAS} , \overline{LCAS}	High
\overline{AS}	High
\overline{RD}	High
\overline{HWR}	High
\overline{LWR}	High

Note: * Remains low in DRAM space RAS down mode.

6.10 Bus Arbiter

The bus controller has a built-in bus arbiter that arbitrates between different bus masters. There are four bus masters: the CPU, DMA controller (DMAC), DRAM interface, and an external bus master. When a bus master has the bus right it can carry out read, write, or refresh access. Each bus master uses a bus request signal to request the bus right. At fixed times the bus arbiter determines priority and uses a bus acknowledge signal to grant the bus to a bus master, which can then operate using the bus.

The bus arbiter checks whether the bus request signal from a bus master is active or inactive, and returns an acknowledge signal to the bus master. When two or more bus masters request the bus, the highest-priority bus master receives an acknowledge signal. The bus master that receives an acknowledge signal can continue to use the bus until the acknowledge signal is deactivated.

The bus master priority order is:

(High) External bus master > DRAM interface > DMAC > CPU (Low)

The bus arbiter samples the bus request signals and determines priority at all times, but it does not always grant the bus immediately, even when it receives a bus request from a bus master with higher priority than the current bus master. Each bus master has certain times at which it can release the bus to a higher-priority bus master.

6.10.1 Operation

CPU: The CPU is the lowest-priority bus master. If the DMAC, DRAM interface, or an external bus master requests the bus while the CPU has the bus right, the bus arbiter transfers the bus right to the bus master that requested it. The bus right is transferred at the following times:

- The bus right is transferred at the boundary of a bus cycle. If word data is accessed by two consecutive byte accesses, however, the bus right is not transferred between the two byte accesses.
- If another bus master requests the bus while the CPU is performing internal operations, such as executing a multiply or divide instruction, the bus right is transferred immediately. The CPU continues its internal operations.
- If another bus master requests the bus while the CPU is in sleep mode, the bus right is transferred immediately.

DMAC: When the DMAC receives an activation request, it requests the bus right from the bus arbiter. If the DMAC is bus master and the DRAM interface or an external bus master requests the bus, the bus arbiter transfers the bus right from the DMAC to the bus master that requested the bus. The bus right is transferred at the following times.

The bus right is transferred when the DMAC finishes transferring one byte or one word. A DMAC transfer cycle consists of a read cycle and a write cycle. The bus right is not transferred between the read cycle and the write cycle.

There is a priority order among the DMAC channels. For details see section 7.4.9, Multiple-Channel Operation.

DRAM Interface: The DRAM interface requests the bus right from the bus arbiter when a refresh cycle request is issued, and releases the bus at the end of the refresh cycle. For details see section 6.5, DRAM Interface.

External Bus Master: When the BRLE bit is set to 1 in BRCCR, the bus can be released to an external bus master. The external bus master has highest priority, and requests the bus right from the bus arbiter by driving the $\overline{\text{BREQ}}$ signal low. Once the external bus master acquires the bus, it keeps the bus until the $\overline{\text{BREQ}}$ signal goes high. While the bus is released to an external bus master, the H8/3006 and H8/3007 chip holds the address bus, data bus, bus control signals ($\overline{\text{AS}}$, $\overline{\text{RD}}$, $\overline{\text{HWR}}$, and $\overline{\text{LWR}}$), and chip select signals ($\overline{\text{CS}}_n$: $n = 7$ to 0) in the high-impedance state, and holds the $\overline{\text{BACK}}$ pin in the low output state.

The bus arbiter samples the $\overline{\text{BREQ}}$ pin at the rise of the system clock (ϕ). If $\overline{\text{BREQ}}$ is low, the bus is released to the external bus master at the appropriate opportunity. The $\overline{\text{BREQ}}$ signal should be held low until the $\overline{\text{BACK}}$ signal goes low.

When the $\overline{\text{BREQ}}$ pin is high in two consecutive samples, the $\overline{\text{BACK}}$ pin is driven high to end the bus-release cycle.

Figure 6.46 shows the timing when the bus right is requested by an external bus master during a read cycle in a two-state access area. There is a minimum interval of three states from when the $\overline{\text{BREQ}}$ signal goes low until the bus is released.

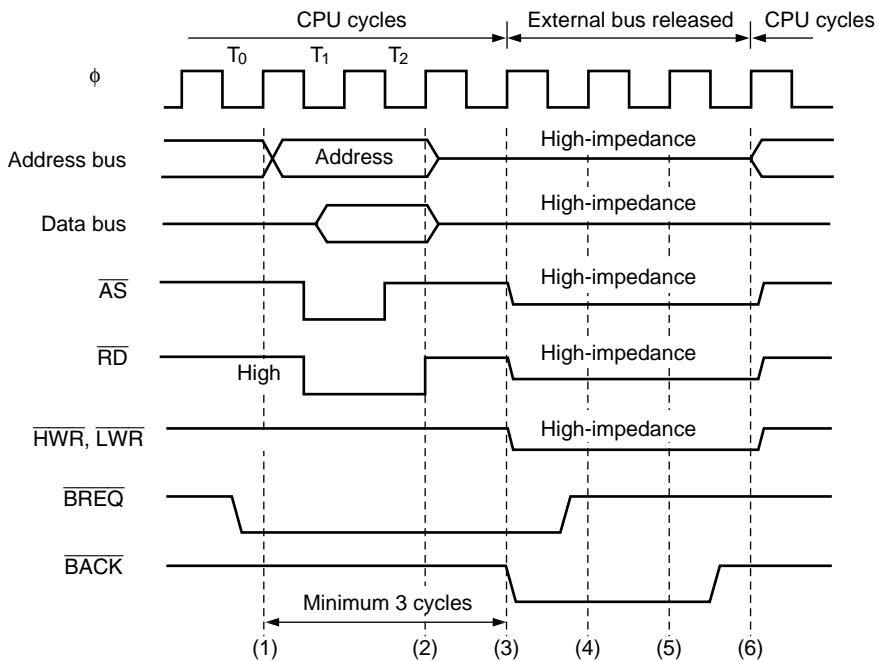

Figure 6.46 Example of External Bus Master Operation

In the event of contention with a bus request from an external bus master when a transition is made to software standby mode, the \overline{BACK} and strobe states may be indeterminate after the transition to software standby mode (see figure 6.34).

When software standby mode is used, the BRLE bit should be cleared to 0 in BRCR before executing the SLEEP instruction.

6.11 Register and Pin Input Timing

6.11.1 Register Write Timing

ABWCR, ASTCR, WCRH, and WCRL Write Timing: Data written to ABWCR, ASTCR, WCRH, and WCRL takes effect starting from the next bus cycle. Figure 6.47 shows the timing when an instruction fetched from area 0 changes area 0 from three-state access to two-state access.

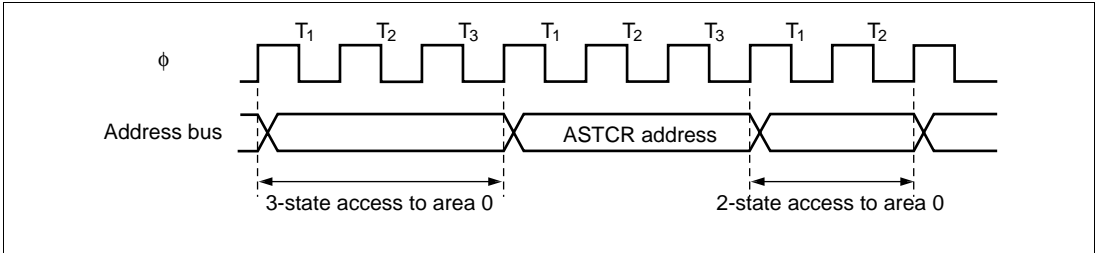

Figure 6.47 ASTCR Write Timing

DDR and CSCR Write Timing: Data written to DDR or CSCR for the port corresponding to the \overline{CS}_n pin to switch between \overline{CS}_n output and generic input takes effect starting from the T_3 state of the DDR write cycle. Figure 6.48 shows the timing when the \overline{CS}_1 pin is changed from generic input to \overline{CS}_1 output.

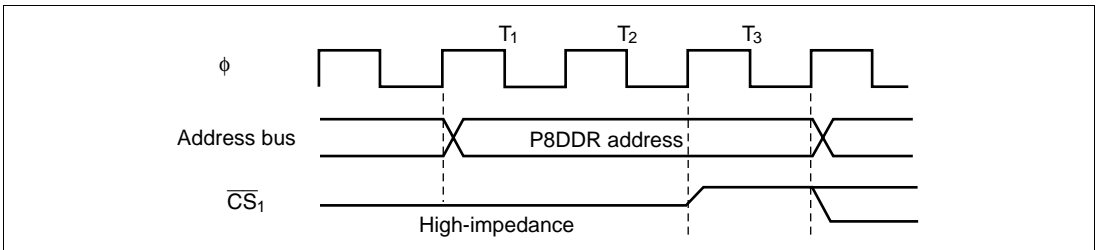

Figure 6.48 DDR Write Timing

BRCR Write Timing: Data written to BRCR to switch between A_{23} , A_{22} , A_{21} , or A_{20} output and generic input or output takes effect starting from the T_3 state of the BRCR write cycle. Figure 6.49 shows the timing when a pin is changed from generic input to A_{23} , A_{22} , A_{21} , or A_{20} output.

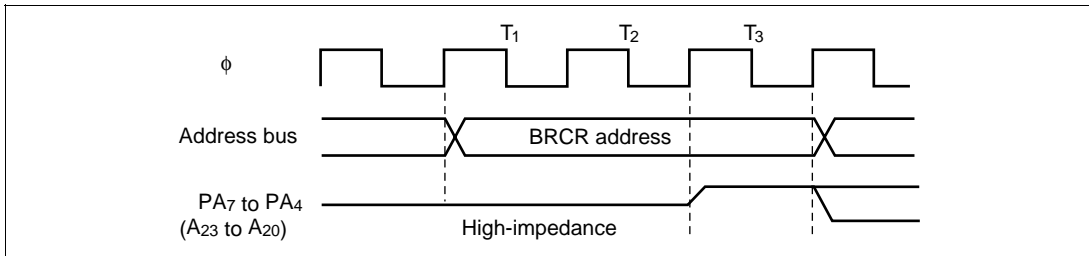

Figure 6.49 BRCR Write Timing

6.11.2 $\overline{\text{BREQ}}$ Pin Input Timing

After driving the $\overline{\text{BREQ}}$ pin low, hold it low until $\overline{\text{BACK}}$ goes low. If $\overline{\text{BREQ}}$ returns to the high level before $\overline{\text{BACK}}$ goes low, the bus arbiter may operate incorrectly.

To terminate the external-bus-released state, hold the $\overline{\text{BREQ}}$ signal high for at least three states. If $\overline{\text{BREQ}}$ is high for too short an interval, the bus arbiter may operate incorrectly.

Section 7 DMA Controller

7.1 Overview

The H8/3006 and H8/3007 have an on-chip DMA controller (DMAC) that can transfer data on up to four channels.

When the DMA controller is not used, it can be independently halted to conserve power. For details see section 19.6, Module Standby Function.

7.1.1 Features

DMAC features are listed below.

- Selection of short address mode or full address mode
 - Short address mode
 - 8-bit source address and 24-bit destination address, or vice versa
 - Maximum four channels available
 - Selection of I/O mode, idle mode, or repeat mode
 - Full address mode
 - 24-bit source and destination addresses
 - Maximum two channels available
 - Selection of normal mode or block transfer mode
- Directly addressable 16-Mbyte address space
- Selection of byte or word transfer
- Activation by internal interrupts, external requests, or auto-request (depending on transfer mode)
 - 16-bit integrated timer unit (ITU) compare match/input capture interrupts (×3)
 - Serial communication interface (SCI channel 0) transmit-data-empty/receive-data-full interrupts
 - External requests
 - Auto-request
 - A/D converter conversion-end interrupt

7.1.2 Block Diagram

Figure 7.1 shows a DMAC block diagram.

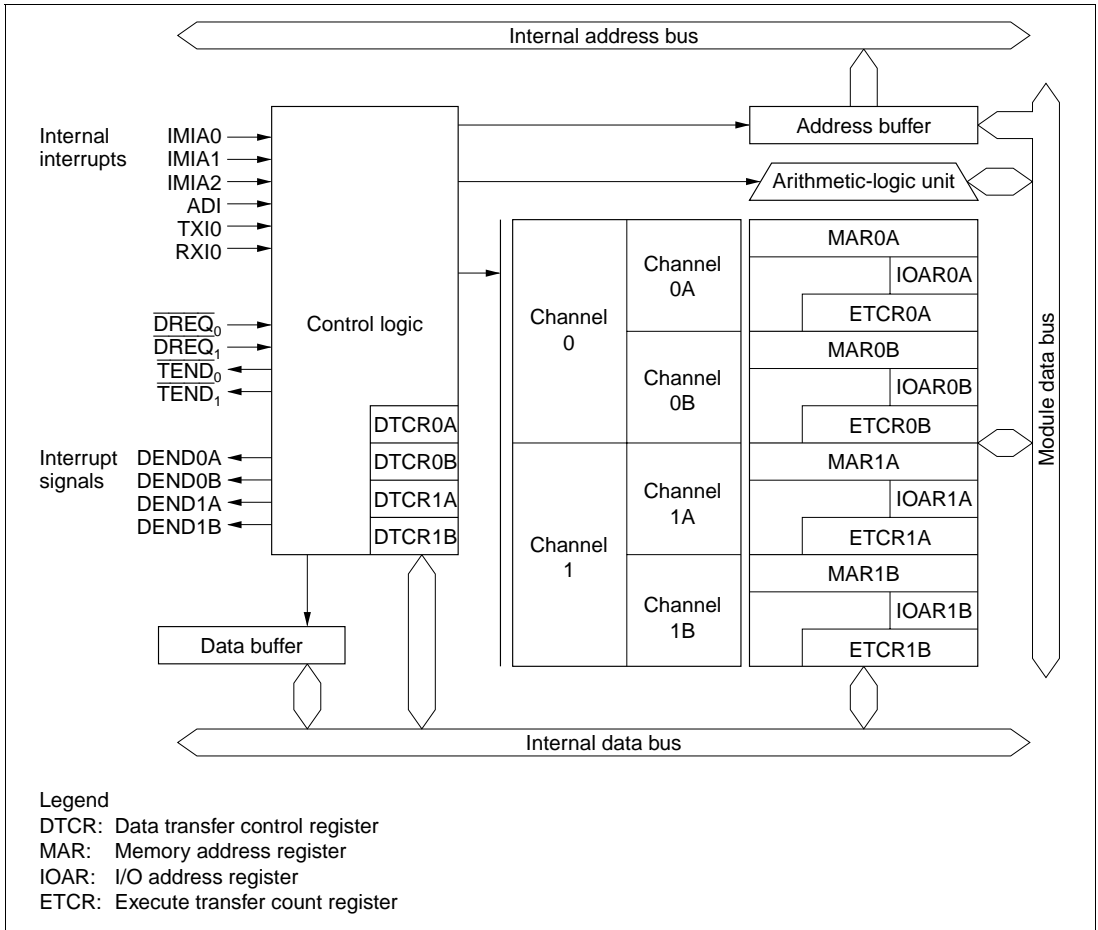

Figure 7.1 Block Diagram of DMAC

7.1.3 Functional Overview

Table 7.1 gives an overview of the DMAC functions.

Table 7.1 DMAC Functional Overview

Transfer Mode		Activation	Address Reg. Length	
			Source	Destination
Short address mode	I/O mode <ul style="list-style-type: none"> Transfers one byte or one word per request Increments or decrements the memory address by 1 or 2 Executes 1 to 65,536 transfers 	<ul style="list-style-type: none"> Compare match/input capture A interrupts from 16-bit timer channels 0 to 2 Transmit-data-empty interrupt from SCI channel 0 	24	8
	Idle mode <ul style="list-style-type: none"> Transfers one byte or one word per request Holds the memory address fixed Executes 1 to 65,536 transfers 	<ul style="list-style-type: none"> Conversion-end interrupt from A/D converter Receive-data-full interrupt from SCI channel 0 	8	24
	Repeat mode <ul style="list-style-type: none"> Transfers one byte or one word per request Increments or decrements the memory address by 1 or 2 Executes a specified number (1 to 255) of transfers, then returns to the initial state and continues 	<ul style="list-style-type: none"> External request 	24	8
Full address mode	Normal mode <ul style="list-style-type: none"> Auto-request <ul style="list-style-type: none"> Retains the transfer request internally Executes a specified number(1 to 65,536) of transfers continuously Selection of burst mode or cycle-steal mode External request <ul style="list-style-type: none"> Transfers one byte or one word per request Executes 1 to 65,536 transfers 	<ul style="list-style-type: none"> Auto-request External request 	24	24
	Block transfer <ul style="list-style-type: none"> Transfers one block of a specified size per request Executes 1 to 65,536 transfers Allows either the source or destination to be a fixed block area Block size can be 1 to 255 bytes or words 	<ul style="list-style-type: none"> Compare match/ input capture A interrupts from 16-bit timer channels 0 to 2 External request Conversion-end interrupt from A/D converter 	24	24

7.1.4 Pin Configuration

Table 7.2 lists the DMAC pins.

Table 7.2 DMAC Pins

Channel	Name	Abbreviation	Input/Output	Function
0	DMA request 0	$\overline{\text{DREQ}}_0$	Input	External request for DMAC channel 0
	Transfer end 0	$\overline{\text{TEND}}_0$	Output	Transfer end on DMAC channel 0
1	DMA request 1	$\overline{\text{DREQ}}_1$	Input	External request for DMAC channel 1
	Transfer end 1	$\overline{\text{TEND}}_1$	Output	Transfer end on DMAC channel 1

Note: External requests cannot be made to channel A in short address mode.

7.1.5 Register Configuration

Table 7.3 lists the DMAC registers.

Table 7.3 DMAC Registers

Channel	Address*	Name	Abbreviation	R/W	Initial Value
0	H'FFF20	Memory address register 0AR	MAR0AR	R/W	Undetermined
	H'FFF21	Memory address register 0AE	MAR0AE	R/W	Undetermined
	H'FFF22	Memory address register 0AH	MAR0AH	R/W	Undetermined
	H'FFF23	Memory address register 0AL	MAR0AL	R/W	Undetermined
	H'FFF26	I/O address register 0A	IOAR0A	R/W	Undetermined
	H'FFF24	Execute transfer count register 0AH	ETCR0AH	R/W	Undetermined
	H'FFF25	Execute transfer count register 0AL	ETCR0AL	R/W	Undetermined
	H'FFF27	Data transfer control register 0A	DTCR0A	R/W	H'00
	H'FFF28	Memory address register 0BR	MAR0BR	R/W	Undetermined
	H'FFF29	Memory address register 0BE	MAR0BE	R/W	Undetermined
	H'FFF2A	Memory address register 0BH	MAR0BH	R/W	Undetermined
	H'FFF2B	Memory address register 0BL	MAR0BL	R/W	Undetermined
	H'FFF2E	I/O address register 0B	IOAR0B	R/W	Undetermined
	H'FFF2C	Execute transfer count register 0BH	ETCR0BH	R/W	Undetermined
	H'FFF2D	Execute transfer count register 0BL	ETCR0BL	R/W	Undetermined
	H'FFF2F	Data transfer control register 0B	DTCR0B	R/W	H'00
	1	H'FFF30	Memory address register 1AR	MAR1AR	R/W
H'FFF31		Memory address register 1AE	MAR1AE	R/W	Undetermined
H'FFF32		Memory address register 1AH	MAR1AH	R/W	Undetermined
H'FFF33		Memory address register 1AL	MAR1AL	R/W	Undetermined
H'FFF36		I/O address register 1A	IOAR1A	R/W	Undetermined
H'FFF34		Execute transfer count register 1AH	ETCR1AH	R/W	Undetermined
H'FFF35		Execute transfer count register 1AL	ETCR1AL	R/W	Undetermined
H'FFF37		Data transfer control register 1A	DTCR1A	R/W	H'00
H'FFF38		Memory address register 1BR	MAR1BR	R/W	Undetermined
H'FFF39		Memory address register 1BE	MAR1BE	R/W	Undetermined
H'FFF3A		Memory address register 1BH	MAR1BH	R/W	Undetermined
H'FFF3B		Memory address register 1BL	MAR1BL	R/W	Undetermined
H'FFF3E		I/O address register 1B	IOAR1B	R/W	Undetermined
H'FFF3C		Execute transfer count register 1BH	ETCR1BH	R/W	Undetermined
H'FFF3D		Execute transfer count register 1BL	ETCR1BL	R/W	Undetermined
H'FFF3F	Data transfer control register 1B	DTCR1B	R/W	H'00	

Note: * The lower 20 bits of the address are indicated.

7.2 Register Descriptions (1) (Short Address Mode)

In short address mode, transfers can be carried out independently on channels A and B. Short address mode is selected by bits DTS2A and DTS1A in data transfer control register A (DTCRA) as indicated in table 7.4.

Table 7.4 Selection of Short and Full Address Modes

Channel	Bit 2 DTS2A	Bit 1 DTS1A	Description
0	1	1	DMAC channel 0 operates as one channel in full address mode
	Other than above		DMAC channels 0A and 0B operate as two independent channels in short address mode
1	1	1	DMAC channel 1 operates as one channel in full address mode
	Other than above		DMAC channels 1A and 1B operate as two independent channels in short address mode

7.2.1 Memory Address Registers (MAR)

A memory address register (MAR) is a 32-bit readable/writable register that specifies a source or destination address. The transfer direction is determined automatically from the activation source.

An MAR consists of four 8-bit registers designated MARR, MARE, MARH, and MARL. All bits of MARR are reserved; they cannot be modified and are always read as 1.

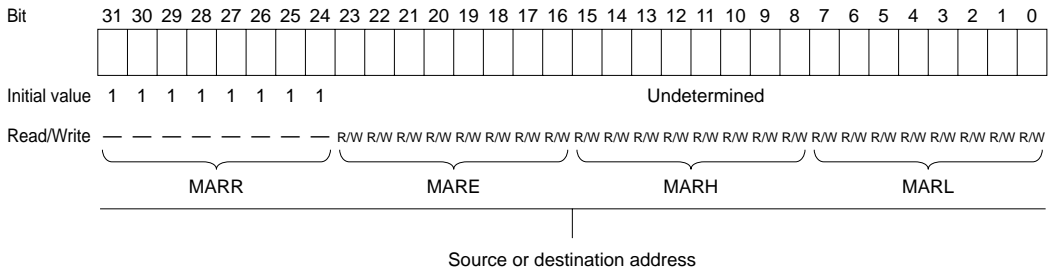

An MAR functions as a source or destination address register depending on how the DMAC is activated: as a destination address register if activation is by a receive-data-full interrupt from the serial communication interface (SCI) (channel 0) or by a conversion-end interrupt from the A/D converter, and as a source address register otherwise.

The MAR value is incremented or decremented each time one byte or word is transferred, automatically updating the source or destination memory address. For details, see section 7.3.4, Data Transfer Control Registers (DTCR).

The MARs are not initialized by a reset or in standby mode.

7.2.2 I/O Address Registers (IOAR)

An I/O address register (IOAR) is an 8-bit readable/writable register that specifies a source or destination address. The IOAR value is the lower 8 bits of the address. The upper 16 address bits are all 1 (H'FFFF).

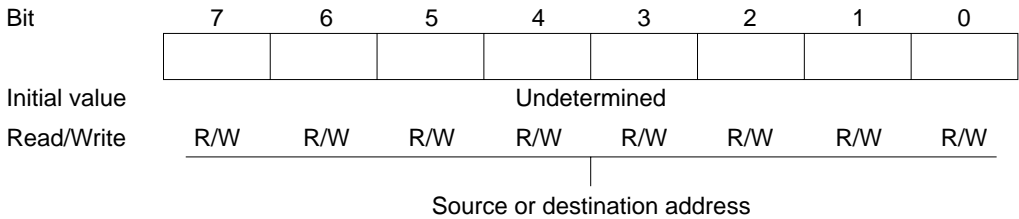

An IOAR functions as a source or destination address register depending on how the DMAC is activated: as a source address register if activation is by a receive-data-full interrupt from the SCI (channel 0) or by a conversion-end interrupt from the A/D converter, and as a destination address register otherwise.

The IOAR value is held fixed. It is not incremented or decremented when a transfer is executed.

The IOARs are not initialized by a reset or in standby mode.

7.2.3 Execute Transfer Count Registers (ETCR)

An execute transfer count register (ETCR) is a 16-bit readable/writable register that specifies the number of transfers to be executed. These registers function in one way in I/O mode and idle mode, and another way in repeat mode.

- I/O mode and idle mode

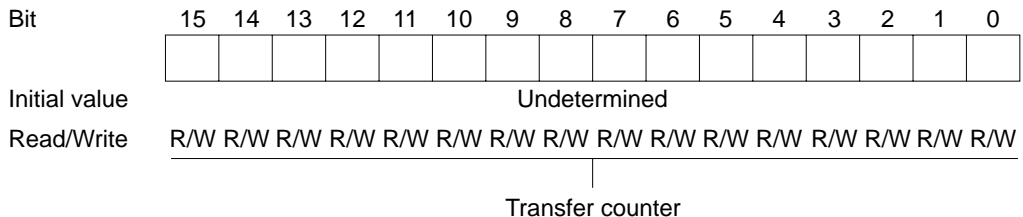

In I/O mode and idle mode, ETCR functions as a 16-bit counter. The count is decremented by 1 each time one transfer is executed. The transfer ends when the count reaches H'0000.

- Repeat mode

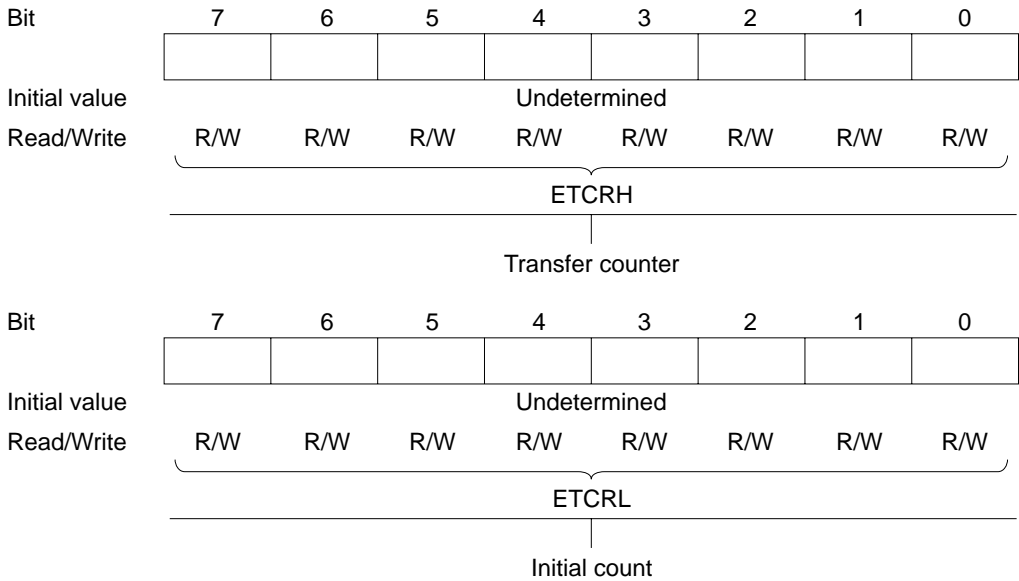

In repeat mode, ETCRH functions as an 8-bit transfer counter and ETCRL holds the initial transfer count. ETCRH is decremented by 1 each time one transfer is executed. When ETCRH reaches H'00, the value in ETCRL is reloaded into ETCRH and the same operation is repeated.

The ETCRs are not initialized by a reset or in standby mode.

7.2.4 Data Transfer Control Registers (DTCR)

A data transfer control register (DTCR) is an 8-bit readable/writable register that controls the operation of one DMAC channel.

Bit	7	6	5	4	3	2	1	0
	DTE	DTSZ	DTID	RPE	DTIE	DTS2	DTS1	DTS0
Initial value	0	0	0	0	0	0	0	0
Read/Write	R/W	R/W	R/W	R/W	R/W	R/W	R/W	R/W

<p>Data transfer enable Enables or disables data transfer</p>	<p>Data transfer size Selects byte or word size</p>	<p>Data transfer increment/decrement Selects whether to increment or decrement the memory address register</p>	<p>Repeat enable Selects repeat mode</p>	<p>Data transfer interrupt enable Enables or disables the CPU interrupt at the end of the transfer</p>	<p>Data transfer select These bits select the data transfer activation source</p>
--	--	---	---	---	--

The DTCRs are initialized to H'00 by a reset and in standby mode.

Bit 7—Data Transfer Enable (DTE): Enables or disables data transfer on a channel. When the DTE bit is set to 1, the channel waits for a transfer to be requested, and executes the transfer when activated as specified by bits DTS2 to DTS0. When DTE is 0, the channel is disabled and does not accept transfer requests. DTE is set to 1 by reading the register when DTE is 0, then writing 1.

Bit 7

DTE	Description
0	Data transfer is disabled. In I/O mode or idle mode, DTE is cleared to 0 (Initial value) when the specified number of transfers have been completed
1	Data transfer is enabled

If DTIE is set to 1, a CPU interrupt is requested when DTE is cleared to 0.

Bit 6—Data Transfer Size (DTSZ): Selects the data size of each transfer.

Bit 6 DTSZ	Description
0	Byte-size transfer (Initial value)
1	Word-size transfer

Bit 5—Data Transfer Increment/Decrement (DTID): Selects whether to increment or decrement the memory address register (MAR) after a data transfer in I/O mode or repeat mode.

Bit 5 DTID	Description
0	MAR is incremented after each data transfer <ul style="list-style-type: none">If DTSZ = 0, MAR is incremented by 1 after each transferIf DTSZ = 1, MAR is incremented by 2 after each transfer
1	MAR is decremented after each data transfer <ul style="list-style-type: none">If DTSZ = 0, MAR is decremented by 1 after each transferIf DTSZ = 1, MAR is decremented by 2 after each transfer

MAR is not incremented or decremented in idle mode.

Bit 4—Repeat Enable (RPE): Selects whether to transfer data in I/O mode, idle mode, or repeat mode.

Bit 4 RPE	Bit 3 DTIE	Description
0	0	I/O mode (Initial value)
	1	
1	0	Repeat mode
	1	Idle mode

Operations in these modes are described in sections 7.4.2, I/O Mode, 7.4.3, Idle Mode, and 7.4.4, Repeat Mode.

Bit 3—Data Transfer Interrupt Enable (DTIE): Enables or disables the CPU interrupt (DEND) requested when the DTE bit is cleared to 0.

Bit 3

DTIE	Description
0	The DEND interrupt requested by DTE is disabled (Initial value)
1	The DEND interrupt requested by DTE is enabled

Bits 2 to 0—Data Transfer Select (DTS2, DTS1, DTS0): These bits select the data transfer activation source. Some of the selectable sources differ between channels A and B.*

Note: * See section 7.3.4, Data Transfer Control Registers (DTCR).

Bit 2 DTS2	Bit 1 DTS1	Bit 0 DTS0	Description
0	0	0	Compare match/input capture A interrupt from 16-bit timer channel 0 (Initial value)
		1	Compare match/input capture A interrupt from 16-bit timer channel 1
	1	0	Compare match/input capture A interrupt from 16-bit timer channel 2
		1	Conversion-end interrupt from A/D converter
1	0	0	Transmit-data-empty interrupt from SCI channel 0
		1	Receive-data-full interrupt from SCI channel 0
	1	0	Falling edge of \overline{DREQ} input (channel B) Transfer in full address mode (channel A)
		1	Low level of \overline{DREQ} input (channel B) Transfer in full address mode (channel A)

The same internal interrupt can be selected as an activation source for two or more channels at once. In that case the channels are activated in a priority order, highest-priority channel first. For the priority order, see section 7.4.9, Multiple-Channel Operation.

When a channel is enabled (DTE = 1), its selected DMAC activation source cannot generate a CPU interrupt.

7.3 Register Descriptions (2) (Full Address Mode)

In full address mode the A and B channels operate together. Full address mode is selected as indicated in table 7.4.

7.3.1 Memory Address Registers (MAR)

A memory address register (MAR) is a 32-bit readable/writable register. MARA functions as the source address register of the transfer, and MARB as the destination address register.

An MAR consists of four 8-bit registers designated MARR, MARE, MARH, and MARL. All bits of MARR are reserved; they cannot be modified and are always read as 1. (Write is invalid.)

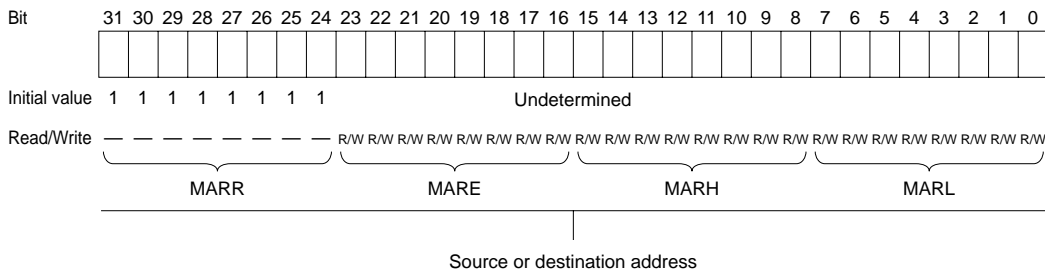

The MAR value is incremented or decremented each time one byte or word is transferred, automatically updating the source or destination memory address. For details, see section 7.3.4, Data Transfer Control Registers (DTCR).

The MARs are not initialized by a reset or in standby mode.

7.3.2 I/O Address Registers (IOAR)

The I/O address registers (IOARs) are not used in full address mode.

7.3.3 Execute Transfer Count Registers (ETCR)

An execute transfer count register (ETCR) is a 16-bit readable/writable register that specifies the number of transfers to be executed. The functions of these registers differ between normal mode and block transfer mode.

- Normal mode

ETCRA

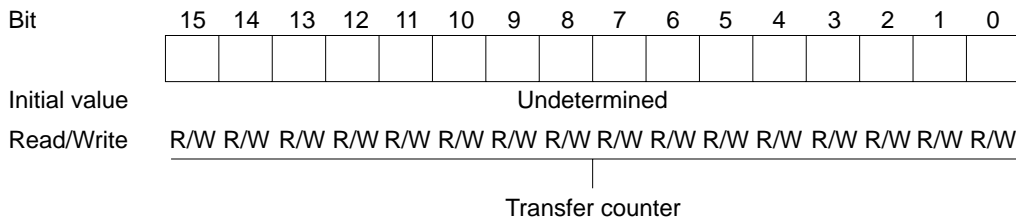

ETCRB: Is not used in normal mode.

In normal mode ETCRA functions as a 16-bit transfer counter. The count is decremented by 1 each time one transfer is executed. The transfer ends when the count reaches H'0000. ETCRB is not used.

- Block transfer mode

ETCRA

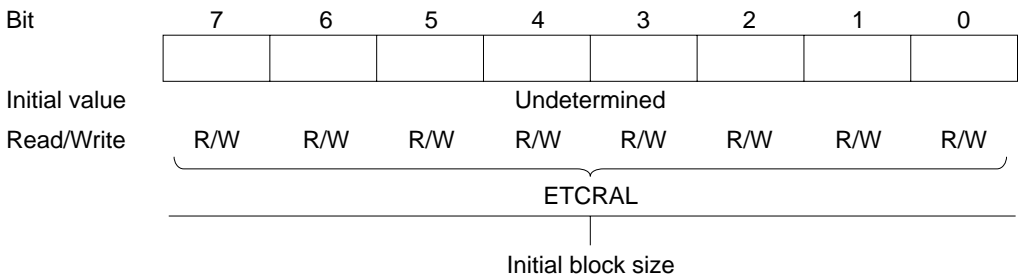
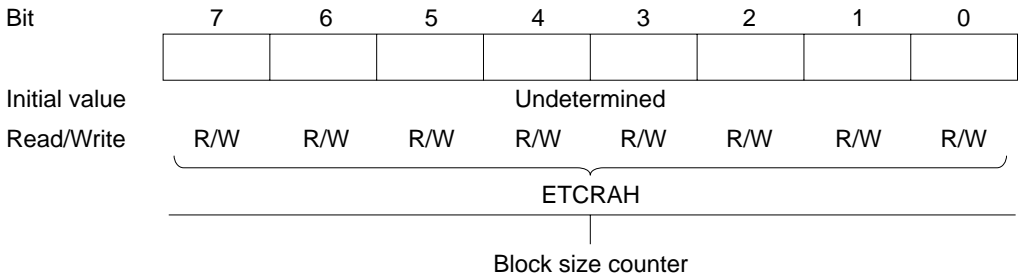

ETCRB

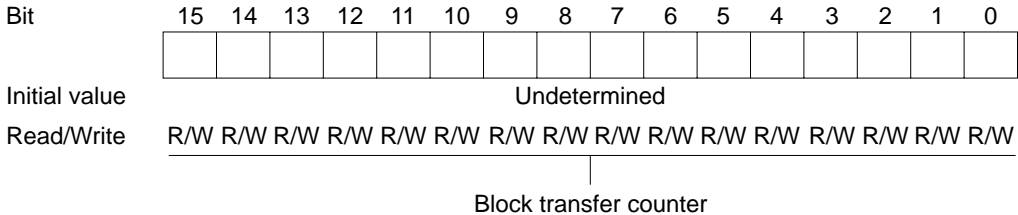

In block transfer mode, ETCRAH functions as an 8-bit block size counter. ETCRAL holds the initial block size. ETCRAH is decremented by 1 each time one byte or word is transferred. When the count reaches H'00, ETCRAH is reloaded from ETCRAL. Blocks consisting of an arbitrary number of bytes or words can be transferred repeatedly by setting the same initial block size value in ETCRAH and ETCRAL.

In block transfer mode ETCRB functions as a 16-bit block transfer counter. ETCRB is decremented by 1 each time one block is transferred. The transfer ends when the count reaches H'0000.

The ETCRs are not initialized by a reset or in standby mode.

7.3.4 Data Transfer Control Registers (DTCR)

The data transfer control registers (DTCRs) are 8-bit readable/writable registers that control the operation of the DMAC channels. A channel operates in full address mode when bits DTS2A and DTS1A are both set to 1 in DTCRA. DTCRA and DTCRB have different functions in full address mode.

DTCRA

Bit	7	6	5	4	3	2	1	0
	DTE	DTSZ	SAID	SAIDE	DTIE	DTS2A	DTS1A	DTS0A
Initial value	0	0	0	0	0	0	0	0
Read/Write	R/W	R/W	R/W	R/W	R/W	R/W	R/W	R/W

<p>Data transfer enable Enables or disables data transfer</p>	<p>Data transfer size Selects byte or word size</p>	<p>Source address increment/decrement Source address increment/decrement enable These bits select whether the source address register (MARA) is incremented, decremented, or held fixed during the data transfer</p>	<p>Data transfer interrupt enable Enables or disables the CPU interrupt at the end of the transfer</p>	<p>Data transfer select 0A Selects block transfer mode</p> <p>Data transfer select 2A and 1A These bits must both be set to 1</p>
--	--	--	---	---

DTCRA is initialized to H'00 by a reset and in standby mode.

Bit 7—Data Transfer Enable (DTE): Together with the DTME bit in DTCRB, this bit enables or disables data transfer on the channel. When the DTME and DTE bits are both set to 1, the channel is enabled. If auto-request is specified, data transfer begins immediately. Otherwise, the channel waits for transfers to be requested. When the specified number of transfers have been completed, the DTE bit is automatically cleared to 0. When DTE is 0, the channel is disabled and does not accept transfer requests. DTE is set to 1 by reading the register when DTE is 0, then writing 1.

Bit 7 DTE	Description
0	Data transfer is disabled (DTE is cleared to 0 when the specified number of transfers have been completed) (Initial value)
1	Data transfer is enabled

If DTIE is set to 1, a CPU interrupt is requested when DTE is cleared to 0.

Bit 6—Data Transfer Size (DTSZ): Selects the data size of each transfer.

Bit 6 DTSZ	Description
0	Byte-size transfer (Initial value)
1	Word-size transfer

Bit 5—Source Address Increment/Decrement (SAID) and,

Bit 4—Source Address Increment/Decrement Enable (SAIDE): These bits select whether the source address register (MARA) is incremented, decremented, or held fixed during the data transfer.

Bit 5 SAID	Bit 4 SAIDE	Description
0	0	MARA is held fixed (Initial value)
	1	MARA is incremented after each data transfer <ul style="list-style-type: none"> If DTSZ = 0, MARA is incremented by 1 after each transfer If DTSZ = 1, MARA is incremented by 2 after each transfer
1	0	MARA is held fixed
	1	MARA is decremented after each data transfer <ul style="list-style-type: none"> If DTSZ = 0, MARA is decremented by 1 after each transfer If DTSZ = 1, MARA is decremented by 2 after each transfer

Bit 3—Data Transfer Interrupt Enable (DTIE): Enables or disables the CPU interrupt (DEND) requested when the DTE bit is cleared to 0.

Bit 3

DTIE	Description
0	The DEND interrupt requested by DTE is disabled (Initial value)
1	The DEND interrupt requested by DTE is enabled

Bits 2 and 1—Data Transfer Select 2A and 1A (DTS2A, DTS1A): A channel operates in full address mode when DTS2A and DTS1A are both set to 1.

Bit 0—Data Transfer Select 0A (DTS0A): Selects normal mode or block transfer mode.

Bit 0

DTS0A	Description
0	Normal mode (Initial value)
1	Block transfer mode

Operations in these modes are described in sections 7.4.5, Normal Mode, and 7.4.6, Block Transfer Mode.

DTCRB

Bit	7	6	5	4	3	2	1	0
	DTME	—	DAID	DAIDE	TMS	DTS2B	DTS1B	DTS0B
Initial value	0	0	0	0	0	0	0	0
Read/Write	R/W	R/W	R/W	R/W	R/W	R/W	R/W	R/W

Data transfer master enable
Enables or disables data transfer, together with the DTE bit, and is cleared to 0 by an interrupt

Reserved bit

Transfer mode select
Selects whether the block area is the source or destination in block transfer mode

**Destination address increment/decrement
Destination address increment/decrement enable**
These bits select whether the destination address register (MARB) is incremented, decremented, or held fixed during the data transfer

Data transfer select 2B to 0B
These bits select the data transfer activation source

DTCRB is initialized to H'00 by a reset and in standby mode.

Bit 7—Data Transfer Master Enable (DTME): Together with the DTE bit in DTCRA, this bit enables or disables data transfer. When the DTME and DTE bits are both set to 1, the channel is enabled. When an NMI interrupt occurs DTME is cleared to 0, suspending the transfer so that the CPU can use the bus. The suspended transfer resumes when DTME is set to 1 again. For further information on operation in block transfer mode, see section 7.6.6, NMI Interrupts and Block Transfer Mode.

DTME is set to 1 by reading the register while DTME = 0, then writing 1.

Bit 7

DTME	Description
0	Data transfer is disabled (DTME is cleared to 0 when an NMI interrupt occurs) (Initial value)
1	Data transfer is enabled

Bit 6—Reserved: Although reserved, this bit can be written and read.

Bit 5—Destination Address Increment/Decrement (DAID) and,

Bit 4—Destination Address Increment/Decrement Enable (DAIDE): These bits select whether the destination address register (MARB) is incremented, decremented, or held fixed during the data transfer.

Bit 5 DAID	Bit 4 DAIDE	Description
0	0	MARB is held fixed (Initial value)
	1	MARB is incremented after each data transfer <ul style="list-style-type: none">• If DTSZ = 0, MARB is incremented by 1 after each data transfer• If DTSZ = 1, MARB is incremented by 2 after each data transfer
1	0	MARB is held fixed
	1	MARB is decremented after each data transfer <ul style="list-style-type: none">• If DTSZ = 0, MARB is decremented by 1 after each data transfer• If DTSZ = 1, MARB is decremented by 2 after each data transfer

Bit 3—Transfer Mode Select (TMS): Selects whether the source or destination is the block area in block transfer mode.

Bit 3 TMS	Description
0	Destination is the block area in block transfer mode (Initial value)
1	Source is the block area in block transfer mode

Bits 2 to 0—Data Transfer Select 2B to 0B (DTS2B, DTS1B, DTS0B): These bits select the data transfer activation source. The selectable activation sources differ between normal mode and block transfer mode.

Normal mode

Bit 2 DTS2B	Bit 1 DTS1B	Bit 0 DTS0B	Description
0	0	0	Auto-request (burst mode) (Initial value)
		1	Cannot be used
	1	0	Auto-request (cycle-steal mode)
		1	Cannot be used
1	0	0	Cannot be used
		1	Cannot be used
	1	0	Falling edge of \overline{DREQ}
		1	Low level input at \overline{DREQ}

Block transfer mode

Bit 2 DTS2B	Bit 1 DTS1B	Bit 0 DTS0B	Description
0	0	0	Compare match/input capture A interrupt from 16-bit timer channel 0 (Initial value)
		1	Compare match/input capture A interrupt from 16-bit timer channel 1
	1	0	Compare match/input capture A interrupt from 16-bit timer channel 2
		1	Conversion-end interrupt from A/D converter
1	0	0	Cannot be used
		1	Cannot be used
	1	0	Falling edge of \overline{DREQ}
		1	Cannot be used

The same internal interrupt can be selected to activate two or more channels. The channels are activated in a priority order, highest priority first. For the priority order, see section 7.4.9, Multiple-Channel Operation.

7.4 Operation

7.4.1 Overview

Table 7.5 summarizes the DMAC modes.

Table 7.5 DMAC Modes

Transfer Mode		Activation	Notes
Short address mode	I/O mode	Compare match/input capture A interrupt from 16-bit timer channels 0 to 2	<ul style="list-style-type: none"> Up to four channels can operate independently Only the B channels support external requests
	Idle mode		
	Repeat mode	Transmit-data-empty and receive-data-full interrupts from SCI channel 0	
		Conversion-end interrupt from A/D converter	
		External request	
Full address mode	Normal mode	Auto-request	<ul style="list-style-type: none"> A and B channels are paired; up to two channels are available
		External request	
	Block transfer mode	Compare match/input capture A interrupt from ITU channels 0 to 2	<ul style="list-style-type: none"> Burst mode transfer or cycle-steal mode transfer can be selected for autorequests.
		Conversion-end interrupt from A/D converter	
	External request		

A summary of operations in these modes follows.

I/O Mode: One byte or word is transferred per request. A designated number of these transfers are executed. A CPU interrupt can be requested at completion of the designated number of transfers. One 24-bit address and one 8-bit address are specified. The transfer direction is determined automatically from the activation source.

Idle Mode: One byte or word is transferred per request. A designated number of these transfers are executed. A CPU interrupt can be requested at completion of the designated number of transfers. One 24-bit address and one 8-bit address are specified. The addresses are held fixed. The transfer direction is determined automatically from the activation source.

Repeat Mode: One byte or word is transferred per request. A designated number of these transfers are executed. When the designated number of transfers are completed, the initial address and counter value are restored and operation continues. No CPU interrupt is requested. One 24-bit address and one 8-bit address are specified. The transfer direction is determined automatically from the activation source.

Normal Mode

- Auto-request

The DMAC is activated by register setup alone, and continues executing transfers until the designated number of transfers have been completed. A CPU interrupt can be requested at completion of the transfers. Both addresses are 24-bit addresses.

- Cycle-steal mode

The bus is released to another bus master after each byte or word is transferred.

- Burst mode

Unless requested by a higher-priority bus master, the bus is not released until the designated number of transfers have been completed.

- External request

One byte or word is transferred per request. A designated number of these transfers are executed. A CPU interrupt can be requested at completion of the designated number of transfers. Both addresses are 24-bit addresses.

Block Transfer Mode: One block of a specified size is transferred per request. A designated number of block transfers are executed. At the end of each block transfer, one address is restored to its initial value. When the designated number of blocks have been transferred, a CPU interrupt can be requested. Both addresses are 24-bit addresses.

7.4.2 I/O Mode

I/O mode can be selected independently for each channel.

One byte or word is transferred at each transfer request in I/O mode. A designated number of these transfers are executed. One address is specified in the memory address register (MAR), the other in the I/O address register (IOAR). The direction of transfer is determined automatically from the activation source. The transfer is from the address specified in IOAR to the address specified in MAR if activated by an SCI channel 0 receive-data-full interrupt or an A/D converter conversion end interrupt, and from the address specified in MAR to the address specified in IOAR otherwise.

Table 7.6 indicates the register functions in I/O mode.

Table 7.6 Register Functions in I/O Mode

Register	Function		Initial Setting	Operation
	Activated by SCI0 Receive-Data-Full Interrupt or A/D Converter Conversion End Interrupt	Other Activation		
<div style="display: flex; justify-content: space-between;"> 23 0 </div> <div style="border: 1px solid black; padding: 5px; margin: 5px 0;"> <div style="display: flex; justify-content: space-between;"> MAR </div> </div>	Destination address register	Source address register	Destination or source address	Incremented or decremented once per transfer
<div style="display: flex; justify-content: space-between;"> 23 7 0 </div> <div style="border: 1px solid black; padding: 5px; margin: 5px 0;"> <div style="display: flex; justify-content: space-between;"> All 1s IOAR </div> </div>	Source address register	Destination address register	Source or destination address	Held fixed
<div style="display: flex; justify-content: space-between;"> 15 0 </div> <div style="border: 1px solid black; padding: 5px; margin: 5px 0;"> <div style="display: flex; justify-content: space-between;"> ETCR </div> </div>	Transfer counter		Number of transfers	Decrementd once per transfer until H'0000 is reached and transfer ends

Legend

MAR: Memory address register

IOAR: I/O address register

ETCR: Execute transfer count register

MAR and IOAR specify the source and destination addresses. MAR specifies a 24-bit source or destination address, which is incremented or decremented as each byte or word is transferred. IOAR specifies the lower 8 bits of a fixed address. The upper 16 bits are all 1s. IOAR is not incremented or decremented.

Figure 7.2 illustrates how I/O mode operates.

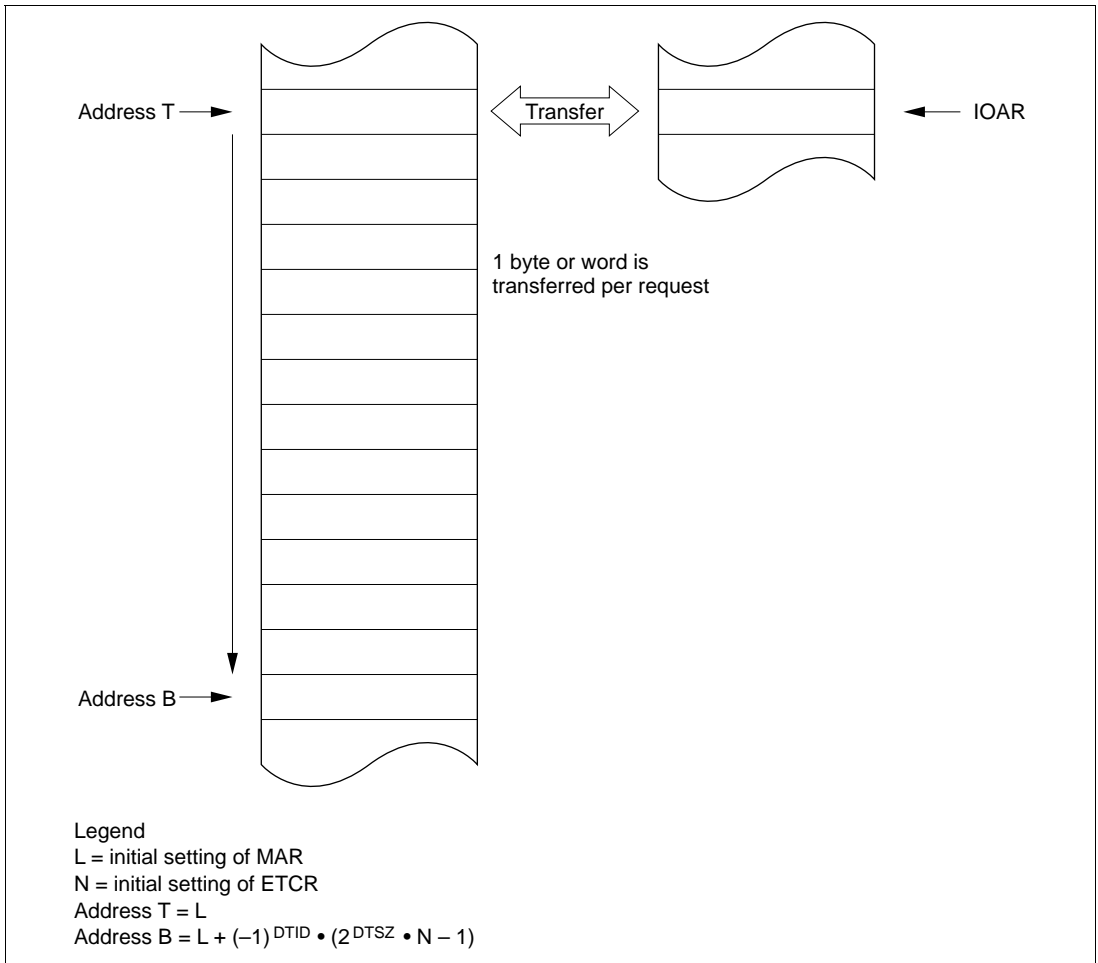

Figure 7.2 Operation in I/O Mode

The transfer count is specified as a 16-bit value in ETCR. The ETCR value is decremented by 1 at each transfer. When the ETCR value reaches H'0000, the DTE bit is cleared and the transfer ends. If the DTIE bit is set to 1, a CPU interrupt is requested at this time. The maximum transfer count is 65,536, obtained by setting ETCR to H'0000.

Transfers can be requested (activated) by compare match/input capture A interrupts from 16-bit timer channels 0 to 2, transmit-data-empty and receive-data-full interrupts from SCI channel 0, conversion-end interrupts from the A/D converter, and external request signals.

For the detailed settings see section 7.2.4, Data Transfer Control Registers (DTCR).

Figure 7.3 shows a sample setup procedure for I/O mode.

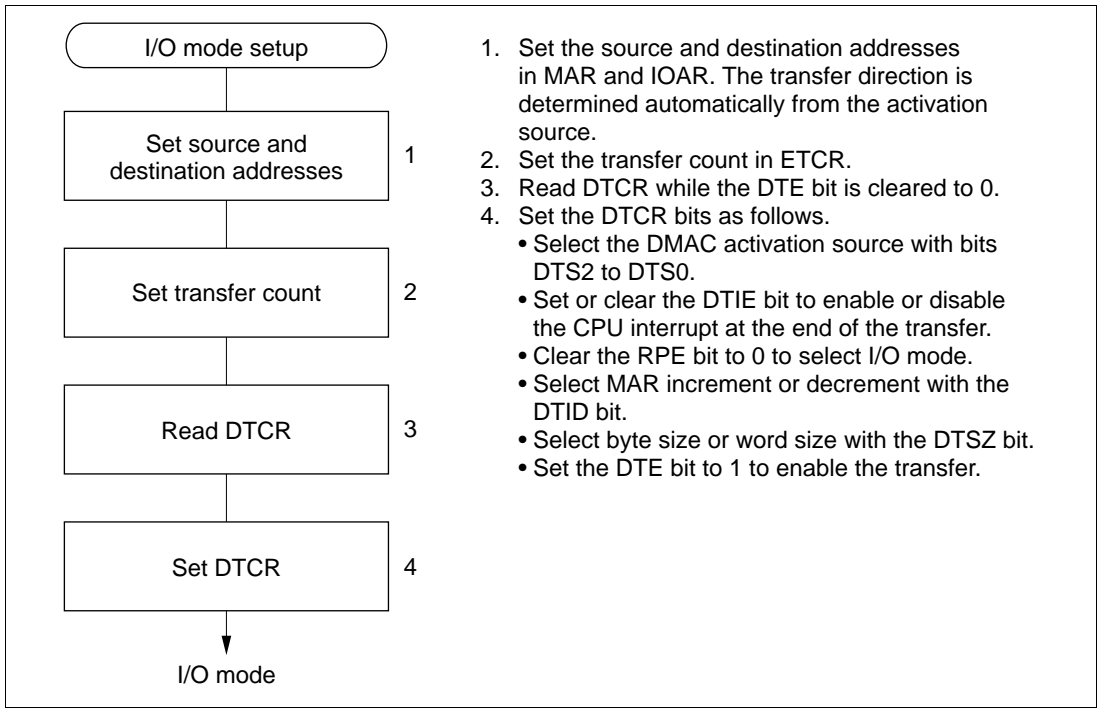

Figure 7.3 I/O Mode Setup Procedure (Example)



7.4.3 Idle Mode

Idle mode can be selected independently for each channel.

One byte or word is transferred at each transfer request in idle mode. A designated number of these transfers are executed. One address is specified in the memory address register (MAR), the other in the I/O address register (IOAR). The direction of transfer is determined automatically from the activation source. The transfer is from the address specified in IOAR to the address specified in MAR if activated by an SCI channel 0 receive-data-full interrupt or an A/D converter conversion end interrupt, and from the address specified in MAR to the address specified in IOAR otherwise.

Table 7.7 indicates the register functions in idle mode.

Table 7.7 Register Functions in Idle Mode

Register	Function		Initial Setting	Operation
	Activated by SCIO Receive- Data-Full Interrupt or A/D Converter Conversion End Interrupt	Other Activation		
23 0 	Destination address register	Source address register	Destination or source address	Held fixed
23 7 0 	Source address register	Destination address register	Source or destination address	Held fixed
15 0 	Transfer counter		Number of transfers	Decrement once per transfer until H'0000 is reached and transfer ends

Legend

MAR: Memory address register

IOAR: I/O address register

ETCR: Execute transfer count register

MAR and IOAR specify the source and destination addresses. MAR specifies a 24-bit source or destination address. IOAR specifies the lower 8 bits of a fixed address. The upper 16 bits are all 1s. MAR and IOAR are not incremented or decremented.

Figure 7.4 illustrates how idle mode operates.

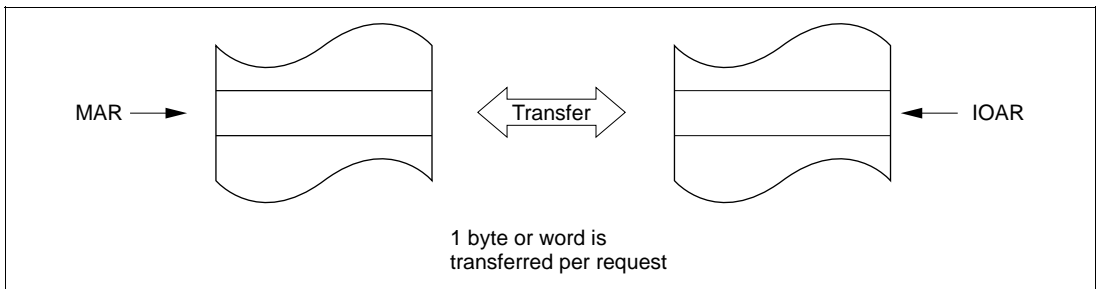

Figure 7.4 Operation in Idle Mode

The transfer count is specified as a 16-bit value in ETCR. The ETCR value is decremented by 1 at each transfer. When the ETCR value reaches H'0000, the DTE bit is cleared, the transfer ends, and a CPU interrupt is requested. The maximum transfer count is 65,536, obtained by setting ETCR to H'0000.

Transfers can be requested (activated) by compare match/input capture A interrupts from 16-bit timer channels 0 to 2, transmit-data-empty and receive-data-full interrupts from SCI channel 0, conversion-end interrupts from the A/D converter, and external request signals.

For the detailed settings see section 7.3.4, Data Transfer Control Registers (DTCR).

Figure 7.5 shows a sample setup procedure for idle mode.

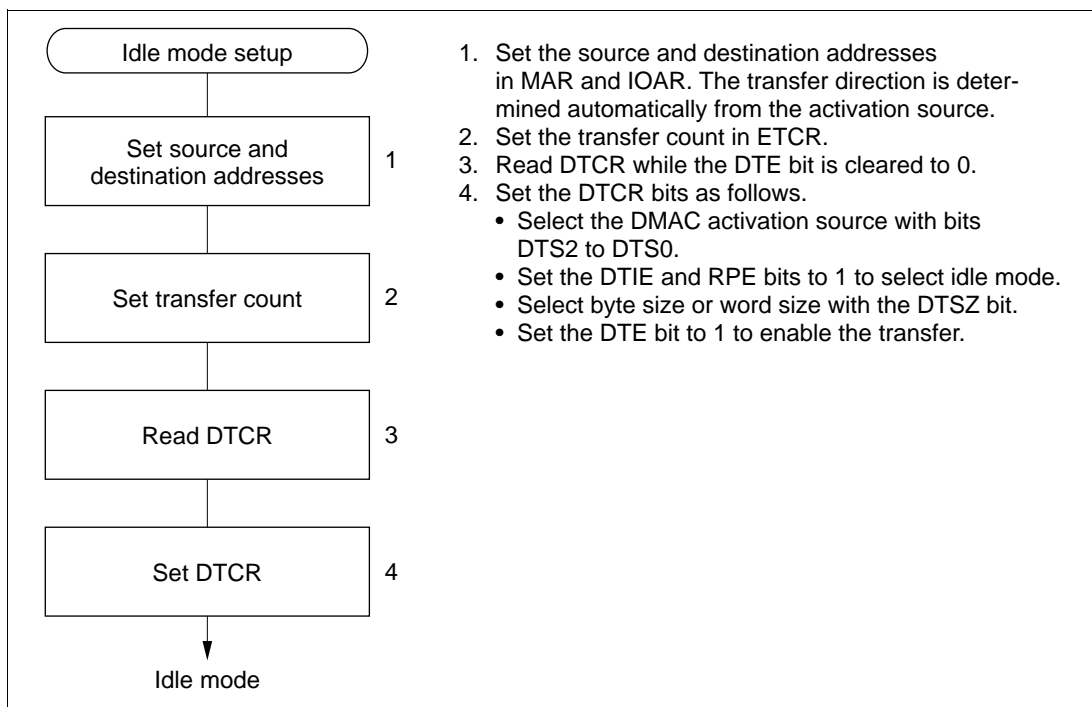

Figure 7.5 Idle Mode Setup Procedure (Example)

7.4.4 Repeat Mode

Repeat mode is useful for cyclically transferring a bit pattern from a table to the programmable timing pattern controller (TPC) in synchronization, for example, with 16-bit timer compare match. Repeat mode can be selected for each channel independently.

One byte or word is transferred per request in repeat mode, as in I/O mode. A designated number of these transfers are executed. One address is specified in the memory address register (MAR), the other in the I/O address register (IOAR). At the end of the designated number of transfers, MAR and ETCRH are restored to their original values and operation continues. The direction of transfer is determined automatically from the activation source. The transfer is from the address specified in IOAR to the address specified in MAR if activated by an SCI channel 0 receive-data-full interrupt or an A/D converter conversion end interrupt, and from the address specified in MAR to the address specified in IOAR otherwise.

Table 7.8 indicates the register functions in repeat mode.

Table 7.8 Register Functions in Repeat Mode

Register	Function			
	Activated by SCIO Receive-Data-Full Interrupt or A/D Converter Conversion End Interrupt	Other Activation	Initial Setting	Operation
<div style="display: flex; justify-content: space-between; align-items: center;"> 23 <div style="border: 1px solid black; padding: 2px; text-align: center;"> 23 MAR 0 </div> 0 </div>	Destination address register	Source address register	Transfer destination or transfer source start address	Incremented or decremented at each transfer until ETCRH reaches H'0000, then restored to initial value
<div style="display: flex; justify-content: space-between; align-items: center;"> 23 <div style="border: 1px solid black; padding: 2px; text-align: center;"> 23 All 1s 7 IOAR 0 </div> 0 </div>	Source address register	Destination address register	Source or destination address	Held fixed
<div style="display: flex; justify-content: center; align-items: center; margin-top: 10px;"> <div style="border: 1px solid black; padding: 2px; text-align: center; margin-right: 10px;"> 7 ETCRH 0 </div> <div style="text-align: center; margin-right: 10px;"> ↑ </div> <div style="border: 1px solid black; padding: 2px; text-align: center;"> 7 ETCRL 0 </div> </div>	Transfer counter		Number of transfers	Decrementd once per transfer until H'0000 is reached, then reloaded from ETCRL
	Initial transfer count		Number of transfers	Held fixed

Legend

MAR: Memory address register

IOAR: I/O address register

ETCR: Execute transfer count register

In repeat mode ETCRH is used as the transfer counter while ETCRL holds the initial transfer count. ETCRH is decremented by 1 at each transfer until it reaches H'00, then is reloaded from ETCRL. MAR is also restored to its initial value, which is calculated from the DTSZ and DTID bits in DTCR. Specifically, MAR is restored as follows:

$$MAR \leftarrow MAR - (-1)^{DTID} \cdot 2^{DTSZ} \cdot ETCRL$$

ETCRH and ETCRL should be initially set to the same value.

In repeat mode transfers continue until the CPU clears the DTE bit to 0. After DTE is cleared to 0, if the CPU sets DTE to 1 again, transfers resume from the state at which DTE was cleared. No CPU interrupt is requested.

As in I/O mode, MAR and IOAR specify the source and destination addresses. MAR specifies a 24-bit source or destination address. IOAR specifies the lower 8 bits of a fixed address. The upper 16 bits are all 1s. IOAR is not incremented or decremented.

Figure 7.6 illustrates how repeat mode operates.

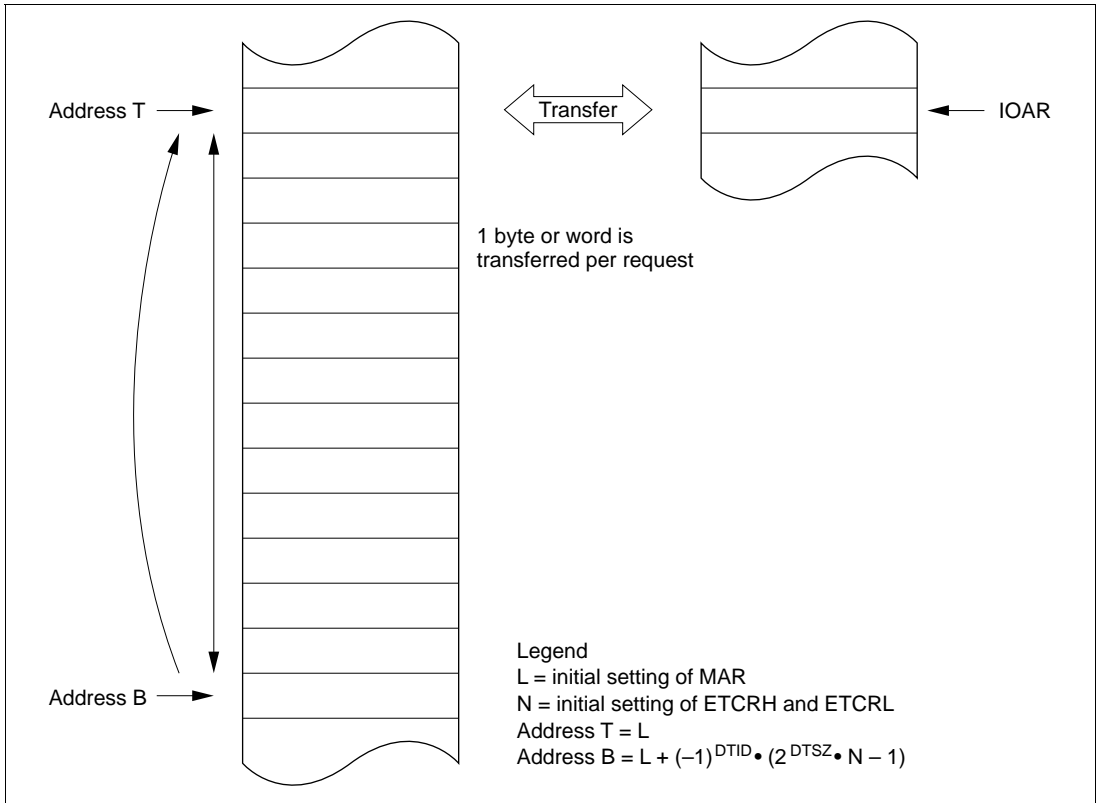

Figure 7.6 Operation in Repeat Mode

The transfer count is specified as an 8-bit value in ETCRH and ETCRL. The maximum transfer count is 255, obtained by setting both ETCRH and ETCRL to H'FF.

Transfers can be requested (activated) by compare match/input capture A interrupts from 16-bit timer channels 0 to 2, transmit-data-empty and receive-data-full interrupts from SCI channel 0, conversion-end interrupts from the A/D converter, and external request signals.

For the detailed settings see section 7.2.4, Data Transfer Control Registers (DTCR).

Figure 7.7 shows a sample setup procedure for repeat mode.

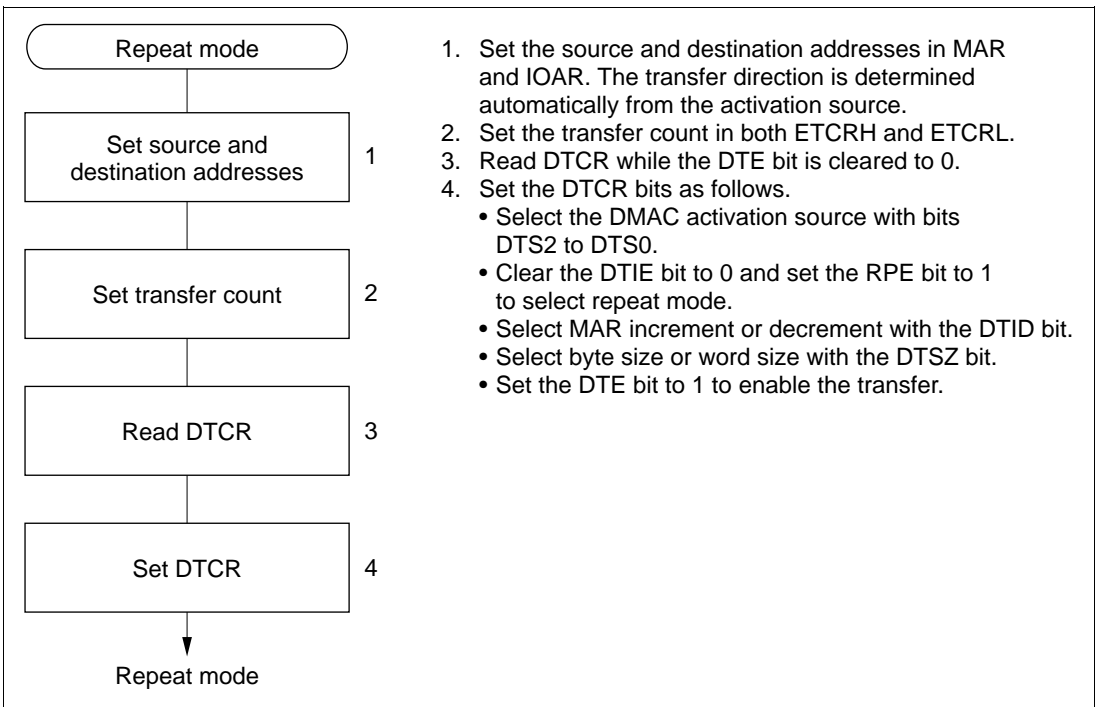





Figure 7.7 Repeat Mode Setup Procedure (Example)

7.4.5 Normal Mode

In normal mode, the A and B channels are combined. One byte or word is transferred per request. A designated number of these transfers are executed. Addresses are specified in MARA and MARB. Table 7.9 indicates the register functions in I/O mode.

Table 7.9 Register Functions in Normal Mode

Register	Function	Initial Setting	Operation
23 	0 Source address register	Transfer source start address	Incremented or decremented once per transfer, or held fixed
23 	0 Destination address register	Transfer destination start address	Incremented or decremented once per transfer, or held fixed
15 	0 Transfer counter	Number of transfers	Decrementd once per transfer

Legend

MARA: Memory address register A

MARB: Memory address register B

ETCRA: Execute transfer count register A

The source and destination addresses are both 24-bit addresses. MARA specifies the source address. MARB specifies the destination address. MARA and MARB can be independently incremented, decremented, or held fixed as data is transferred.

The transfer count is specified as a 16-bit value in ETCRA. The ETCRA value is decremented by 1 at each transfer. When the ETCRA value reaches H'0000, the DTE bit is cleared and the transfer ends. If the DTIE bit is set to 1, a CPU interrupt is requested at this time. The maximum transfer count is 65,536, obtained by setting ETCRA to H'0000.

Figure 7.8 illustrates how normal mode operates.

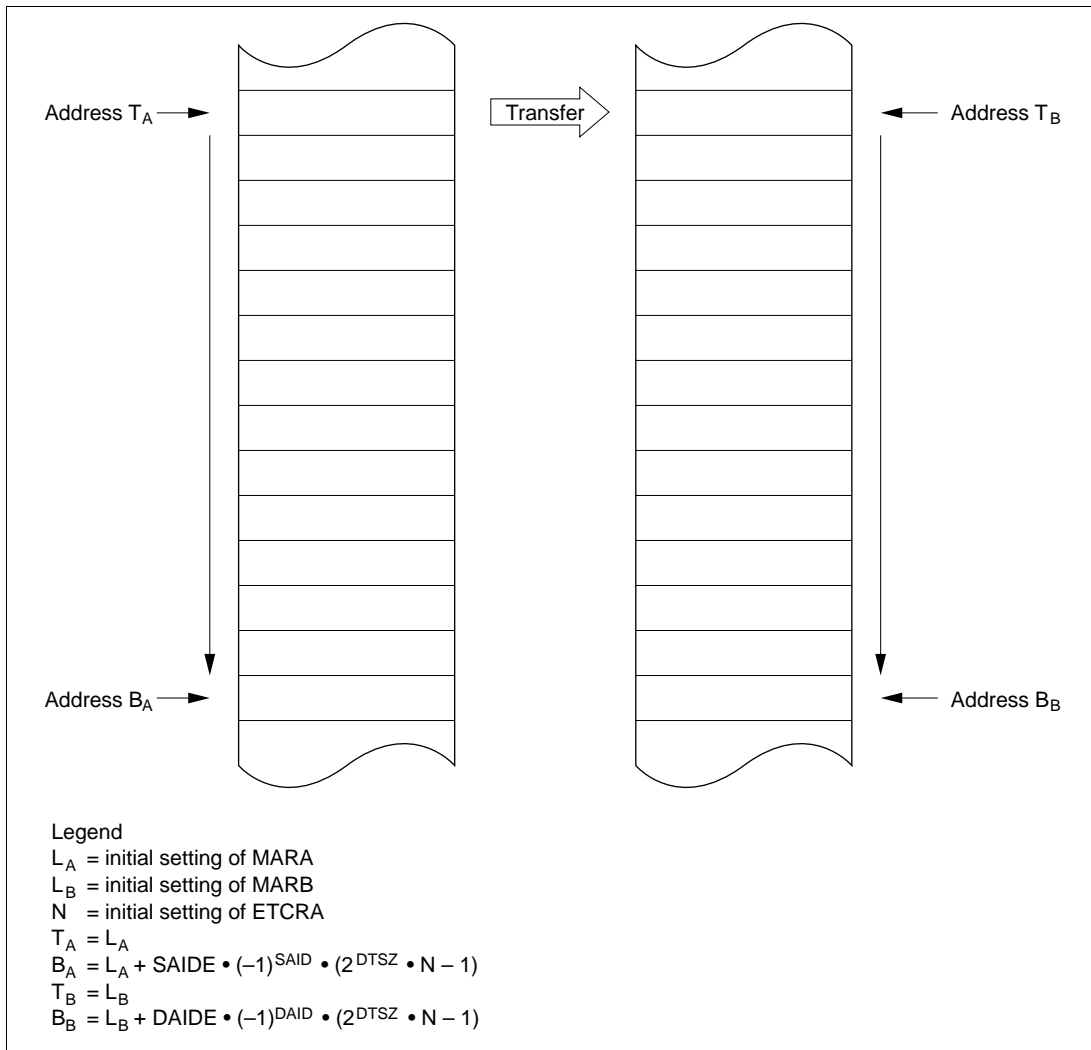

Figure 7.8 Operation in Normal Mode

Transfers can be requested (activated) by an external request or auto-request. An auto-requested transfer is activated by the register settings alone. The designated number of transfers are executed automatically. Either cycle-steal or burst mode can be selected. In cycle-steal mode, the DMAC releases the bus temporarily after each transfer. In burst mode, the DMAC keeps the bus until the transfers are completed, unless there is a bus request from a higher-priority bus master.

For the detailed settings see section 7.3.4, Data Transfer Control Registers (DTCR).

Figure 7.9 shows a sample setup procedure for normal mode.

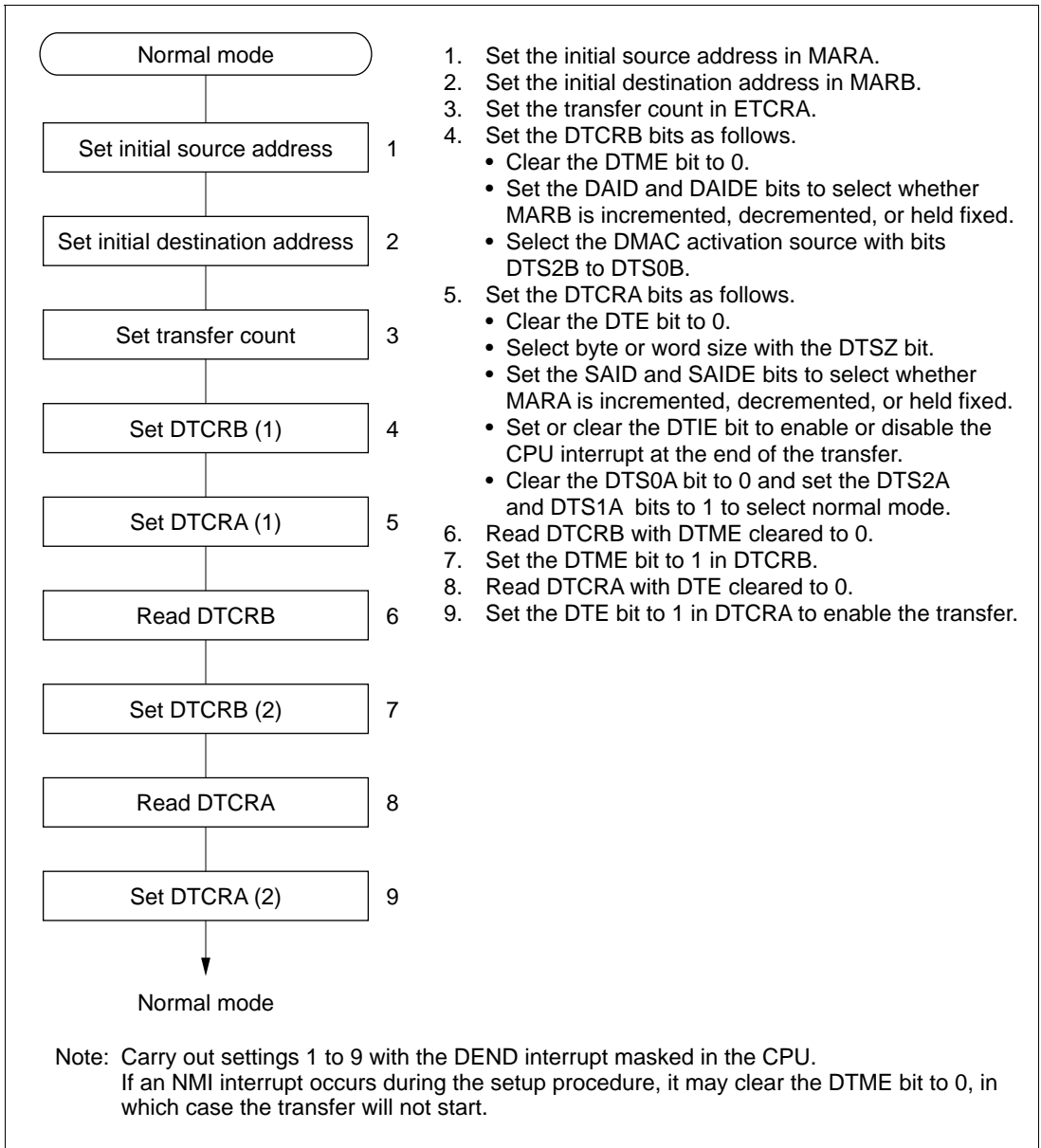



Figure 7.9 Normal Mode Setup Procedure (Example)

7.4.6 Block Transfer Mode

In block transfer mode, the A and B channels are combined. One block of a specified size is transferred per request. A designated number of block transfers are executed. Addresses are specified in MARA and MARB. The block area address can be either held fixed or cycled.

Table 7.10 indicates the register functions in block transfer mode.

Table 7.10 Register Functions in Block Transfer Mode

Register	Function	Initial Setting	Operation
<div style="display: flex; justify-content: space-between;"> 23 0 </div> <div style="border: 1px solid black; padding: 5px; margin: 5px 0;"> <div style="display: flex; justify-content: space-between;"> MARA </div> </div>	Source address register	Transfer source start address	Incremented or decremented once per transfer, or held fixed
<div style="display: flex; justify-content: space-between;"> 23 0 </div> <div style="border: 1px solid black; padding: 5px; margin: 5px 0;"> <div style="display: flex; justify-content: space-between;"> MARB </div> </div>	Destination address register	Transfer destination start address	Incremented or decremented once per transfer, or held fixed
<div style="display: flex; justify-content: space-between;"> 7 0 </div> <div style="border: 1px solid black; padding: 5px; margin: 5px 0;"> <div style="display: flex; justify-content: space-between;"> ETCRAH </div> </div>	Block size counter	Block size	Decrementd once per transfer until H'00 is reached, then reloaded from ETCRL
			
<div style="display: flex; justify-content: space-between;"> 7 0 </div> <div style="border: 1px solid black; padding: 5px; margin: 5px 0;"> <div style="display: flex; justify-content: space-between;"> ETCRL </div> </div>	Initial block size	Block size	Held fixed
<div style="display: flex; justify-content: space-between;"> 15 0 </div> <div style="border: 1px solid black; padding: 5px; margin: 5px 0;"> <div style="display: flex; justify-content: space-between;"> ETCRB </div> </div>	Block transfer counter	Number of block transfers	Decrementd once per block transfer until H'0000 is reached and the transfer ends

Legend

MARA: Memory address register A

MARB: Memory address register B

ETCRA: Execute transfer count register A

ETCRB: Execute transfer count register B

The source and destination addresses are both 24-bit addresses. MARA specifies the source address. MARB specifies the destination address. MARA and MARB can be independently incremented, decremented, or held fixed as data is transferred. One of these registers operates as a block area register: even if it is incremented or decremented, it is restored to its initial value at the end of each block transfer. The TMS bit in DTCRB selects whether the block area is the source or destination.

If M (1 to 255) is the size of the block transferred at each request and N (1 to 65,536) is the number of blocks to be transferred, then ETCRAH and ETCRAL should initially be set to M and ETCRB should initially be set to N.

Figure 7.10 illustrates how block transfer mode operates. In this figure, bit TMS is cleared to 0, meaning the block area is the destination.

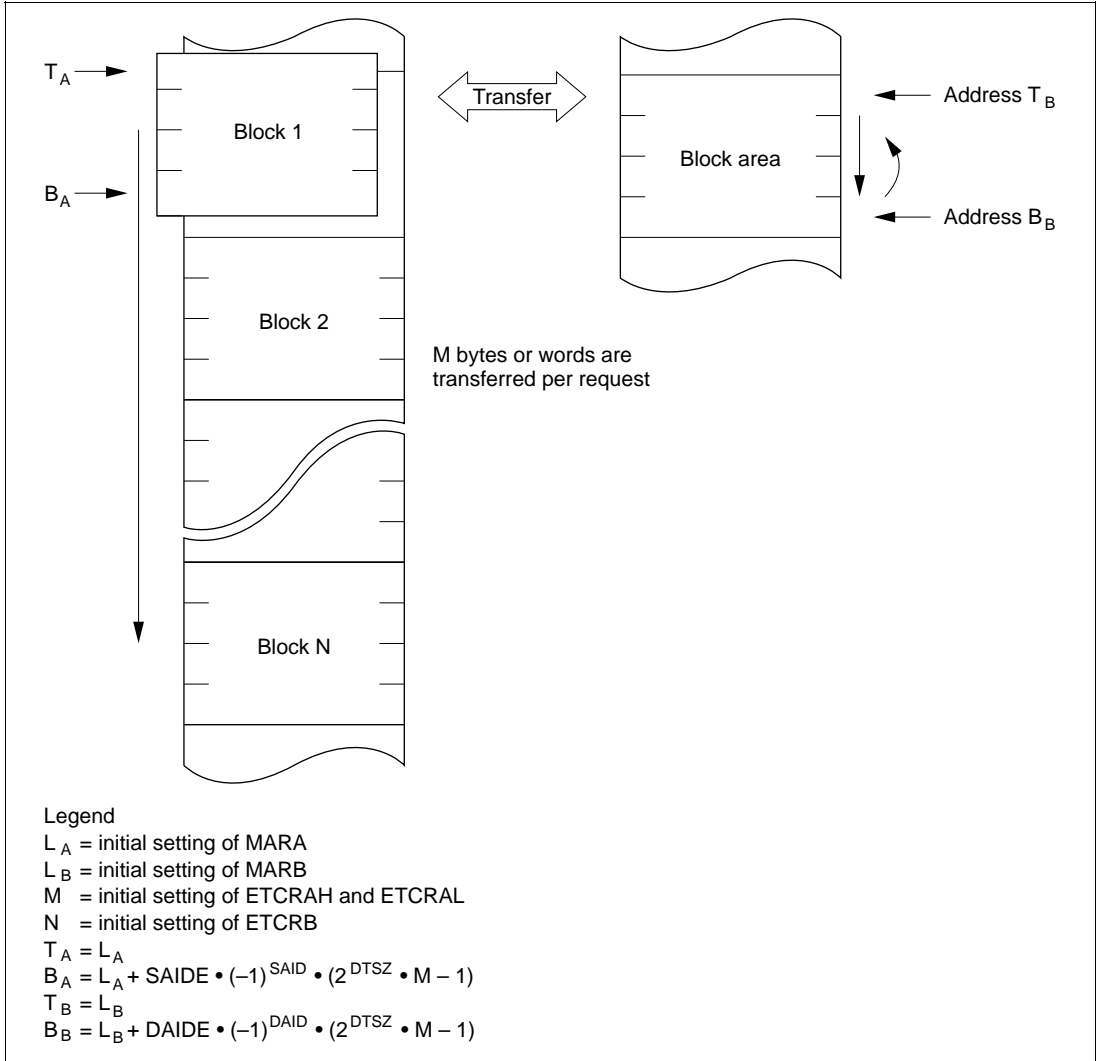

Figure 7.10 Operation in Block Transfer Mode

When activated by a transfer request, the DMAC executes a burst transfer. During the transfer MARA and MARB are updated according to the DTCCR settings, and ETCRAH is decremented. When ETCRAH reaches H'00, it is reloaded from ETCRAL to restore the initial value. The memory address register of the block area is also restored to its initial value, and ETCRB is decremented. If ETCRB is not H'0000, the DMAC then waits for the next transfer request. ETCRAH and ETCRAL should be initially set to the same value.

The above operation is repeated until ETCRB reaches H'0000, at which point the DTE bit is cleared to 0 and the transfer ends. If the DTIE bit is set to 1, a CPU interrupt is requested at this time.

Figure 7.11 shows examples of a block transfer with byte data size when the block area is the destination. In (a), the block area address is cycled. In (b), the block area address is held fixed.

Transfers can be requested (activated) by compare match/input capture A interrupts from 16-bit timer channels 0 to 2, by a conversion-end interrupt from the A/D converter, and by external request signals.

For the detailed settings see section 7.3.4, Data Transfer Control Registers (DTCCR).

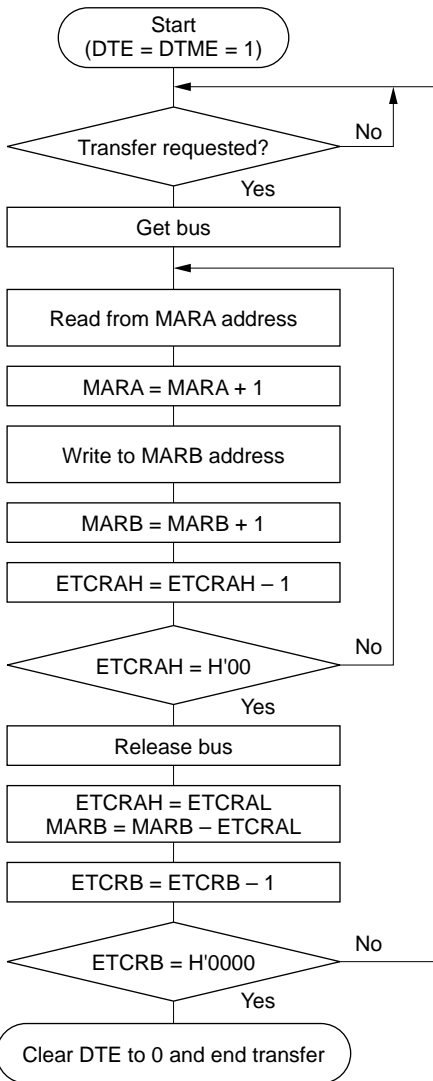

a. DTSZ = TMS = 0
 SAID = DAID = 0
 SAIDE = DAIDE = 1

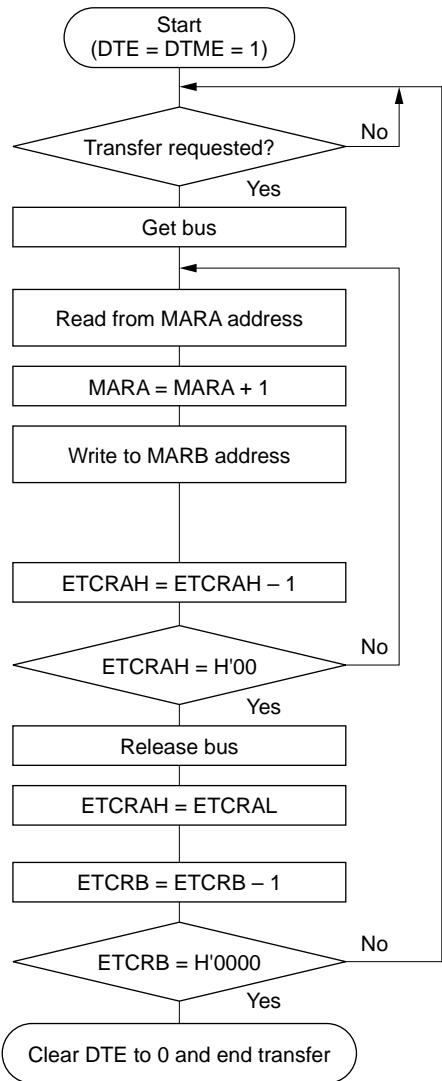

b. DTSZ = TMS = 0
 SAID = 0
 SAIDE = 1
 DAIDE = 0

Figure 7.11 Block Transfer Mode Flowcharts

Figure 7.12 shows a sample setup procedure for block transfer mode.

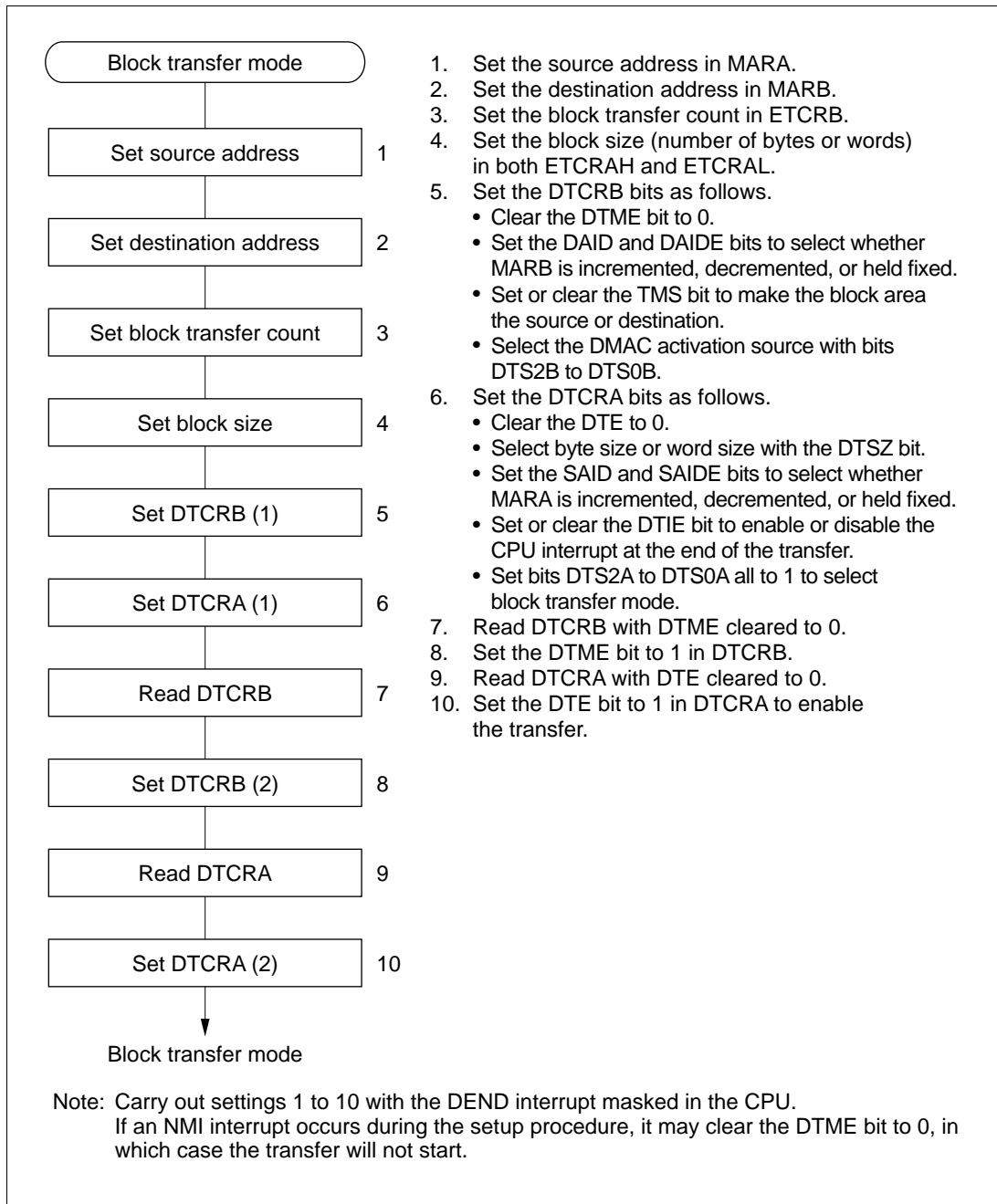

Figure 7.12 Block Transfer Mode Setup Procedure (Example)

7.4.7 DMAC Activation

The DMAC can be activated by an internal interrupt, external request, or auto-request. The available activation sources differ depending on the transfer mode and channel as indicated in table 7.11.

Table 7.11 DMAC Activation Sources

Activation Source		Short Address Mode		Full Address Mode	
		Channels	Channels	Normal	Block
		0A and 1A	0B and 1B		
Internal interrupts	IMIA0	Yes	Yes	No	Yes
	IMIA1	Yes	Yes	No	Yes
	IMIA2	Yes	Yes	No	Yes
	ADI	Yes	Yes	No	Yes
	TXI0	Yes	Yes	No	No
	RXI0	Yes	Yes	No	No
External requests	Falling edge of DREQ	No	Yes	Yes	Yes
	Low input at $\overline{\text{DREQ}}$	No	Yes	Yes	No
Auto-request		No	No	Yes	No

Activation by Internal Interrupts: When an interrupt request is selected as a DMAC activation source and the DTE bit is set to 1, that interrupt request is not sent to the CPU. It is not possible for an interrupt request to activate the DMAC and simultaneously generate a CPU interrupt.

When the DMAC is activated by an interrupt request, the interrupt request flag is cleared automatically. If the same interrupt is selected to activate two or more channels, the interrupt request flag is cleared when the highest-priority channel is activated, but the transfer request is held pending on the other channels in the DMAC, which are activated in their priority order.

Activation by External Request: If an external request ($\overline{\text{DREQ}}$ pin) is selected as an activation source, the $\overline{\text{DREQ}}$ pin becomes an input pin and the corresponding $\overline{\text{TEND}}$ pin becomes an output pin, regardless of the port data direction register (DDR) settings. The $\overline{\text{DREQ}}$ input can be level-sensitive or edge-sensitive.

In short address mode and normal mode, an external request operates as follows. If edge sensing is selected, one byte or word is transferred each time a high-to-low transition of the $\overline{\text{DREQ}}$ input is detected. If the next edge is input before the transfer is completed, the next transfer may not be executed. If level sensing is selected, the transfer continues while $\overline{\text{DREQ}}$ is low, until the transfer is completed. The bus is released temporarily after each byte or word has been transferred, however. If the $\overline{\text{DREQ}}$ input goes high during a transfer, the transfer is suspended after the current byte or word has been transferred. When $\overline{\text{DREQ}}$ goes low, the request is held internally until one byte or word has been transferred. The $\overline{\text{TEND}}$ signal goes low during the last write cycle.

In block transfer mode, an external request operates as follows. Only edge-sensitive transfer requests are possible in block transfer mode. Each time a high-to-low transition of the $\overline{\text{DREQ}}$ input is detected, a block of the specified size is transferred. The $\overline{\text{TEND}}$ signal goes low during the last write cycle in each block.

Activation by Auto-Request: The transfer starts as soon as enabled by register setup, and continues until completed. Cycle-steal mode or burst mode can be selected.

In cycle-steal mode, the DMAC releases the bus temporarily after transferring each byte or word. Normally, DMAC cycles alternate with CPU cycles.

In burst mode, the DMAC keeps the bus until the transfer is completed, unless there is a higher-priority bus request. If there is a higher-priority bus request, the bus is released after the current byte or word has been transferred.

7.4.8 DMAC Bus Cycle

Figure 7.13 shows an example of the timing of the basic DMAC bus cycle. This example shows a word-size transfer from a 16-bit two-state access area to an 8-bit three-state access area. When the DMAC gets the bus from the CPU, after one dead cycle (T_d), it reads from the source address and writes to the destination address. During these read and write operations the bus is not released even if there is another bus request. DMAC cycles comply with bus controller settings in the same way as CPU cycles.

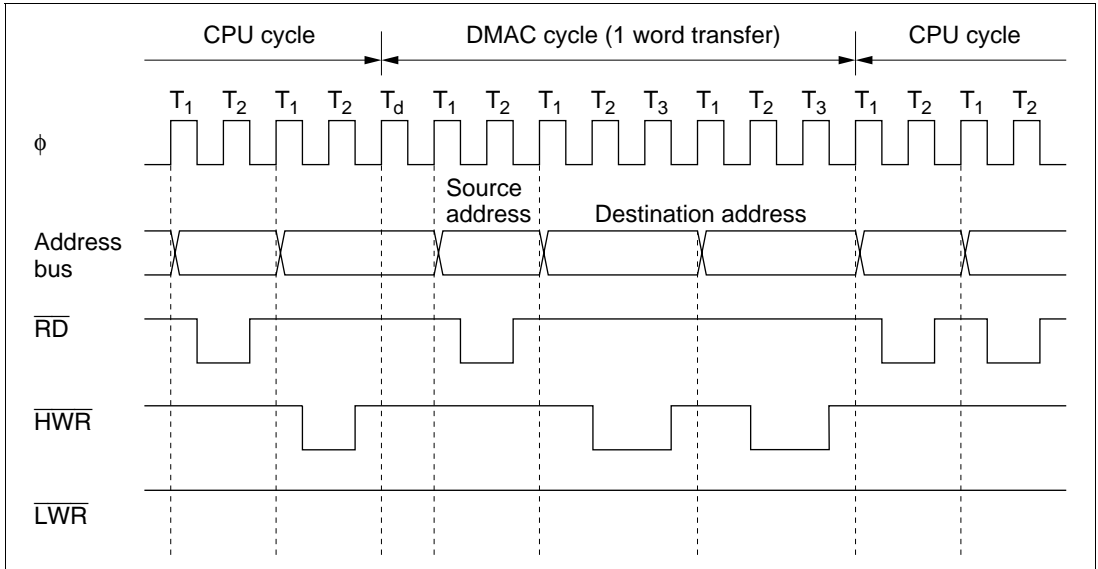

Figure 7.13 DMA Transfer Bus Timing (Example)

Figure 7.14 shows the timing when the DMAC is activated by low input at a $\overline{\text{DREQ}}$ pin. This example shows a word-size transfer from a 16-bit two-state access area to another 16-bit two-state access area. The DMAC continues the transfer while the $\overline{\text{DREQ}}$ pin is held low.

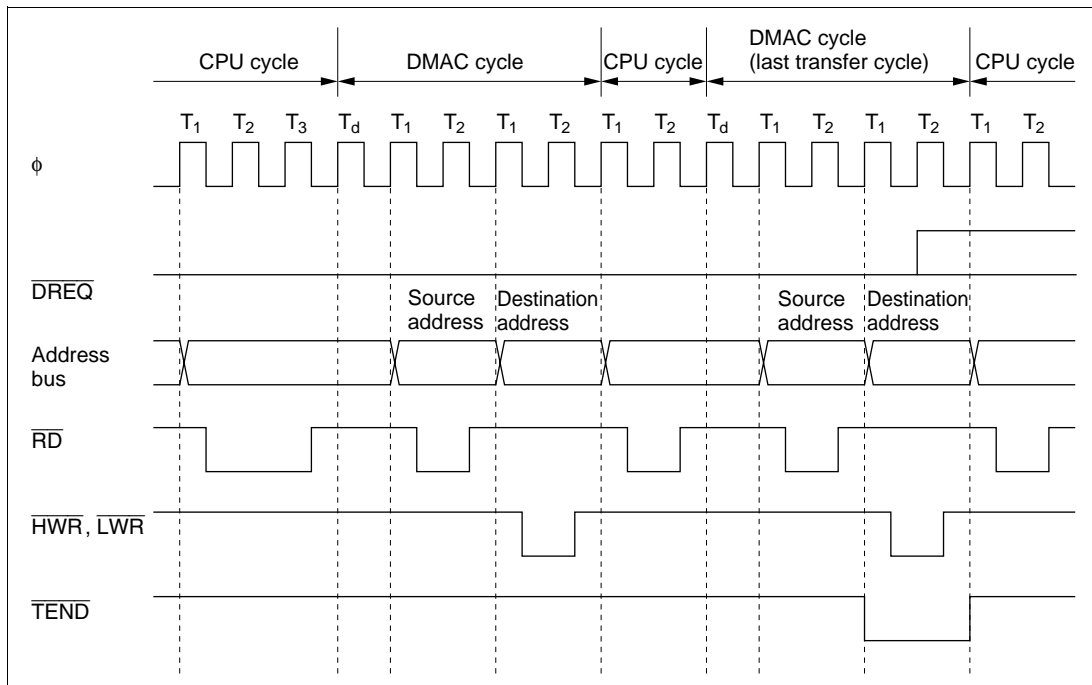

Figure 7.14 Bus Timing of DMA Transfer Requested by Low $\overline{\text{DREQ}}$ Input

Figure 7.15 shows an auto-requested burst-mode transfer. This example shows a transfer of three words from a 16-bit two-state access area to another 16-bit two-state access area.

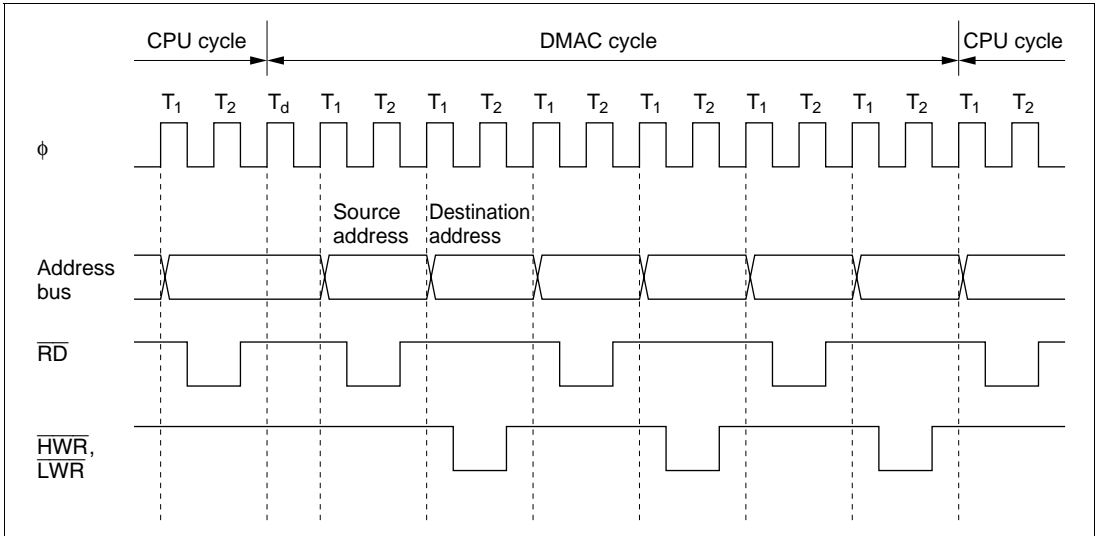

Figure 7.15 Burst DMA Bus Timing

When the DMAC is activated from a \overline{DREQ} pin there is a minimum interval of four states from when the transfer is requested until the DMAC starts operating*. The \overline{DREQ} pin is not sampled during the time between the transfer request and the start of the transfer. In short address mode and normal mode, the pin is next sampled at the end of the read cycle. In block transfer mode, the pin is next sampled at the end of one block transfer.

Note: * The minimum response time is also four states when the DMAC is activated by an internal module interrupt.

Figure 7.16 shows the timing when the DMAC is activated by the falling edge of $\overline{\text{DREQ}}$ in normal mode.

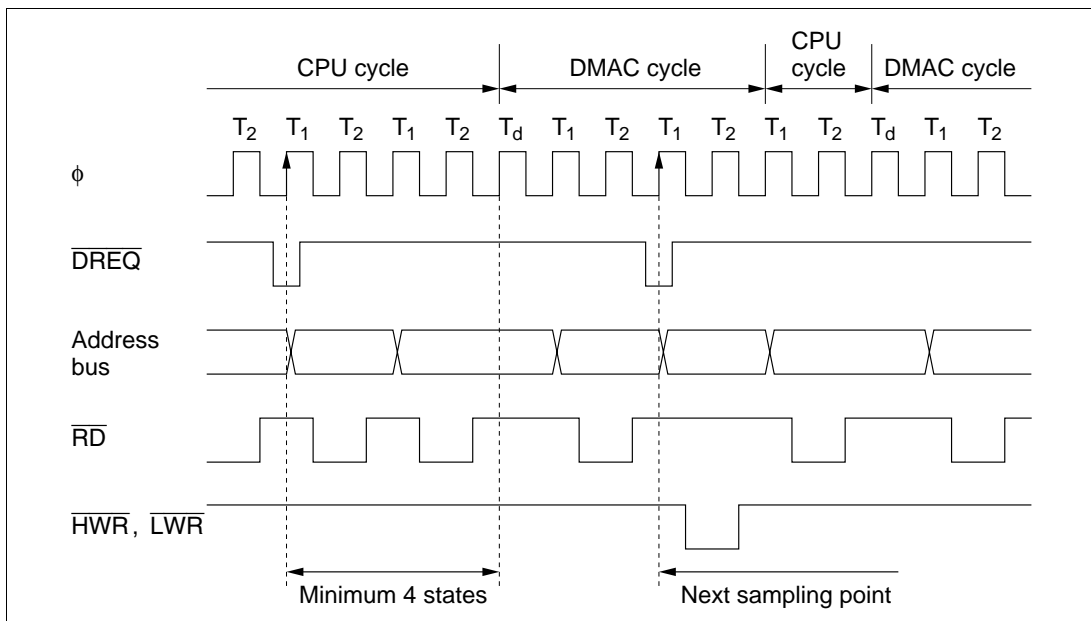

Figure 7.16 Timing of DMAC Activation by Falling Edge of $\overline{\text{DREQ}}$ in Normal Mode

Figure 7.17 shows the timing when the DMAC is activated by level-sensitive low $\overline{\text{DREQ}}$ input in normal mode.

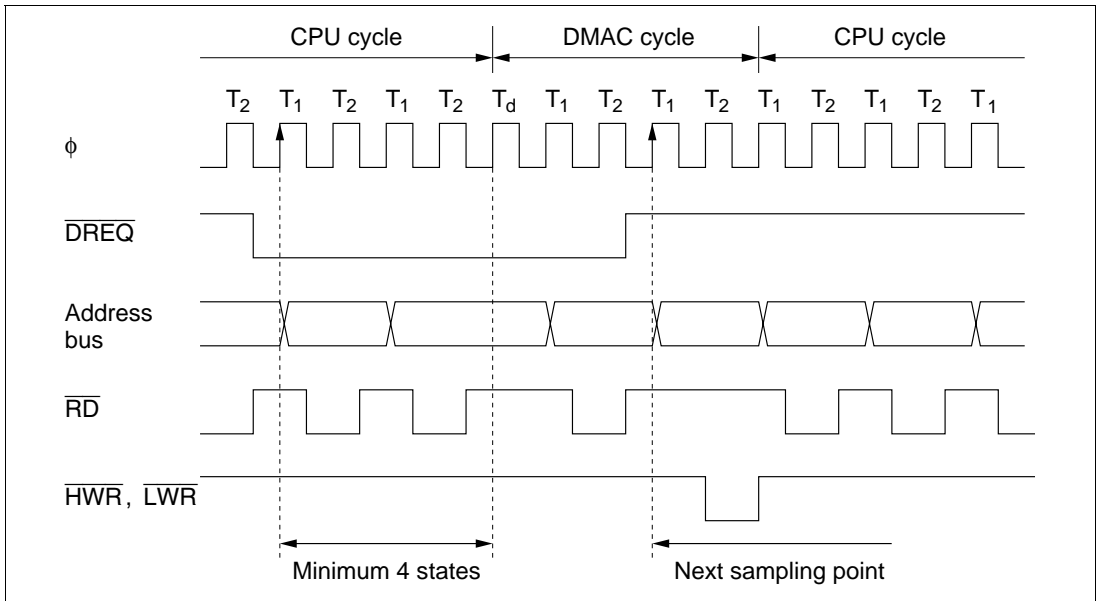

Figure 7.17 Timing of DMAC Activation by Low $\overline{\text{DREQ}}$ Level in Normal Mode

Figure 7.18 shows the timing when the DMAC is activated by the falling edge of $\overline{\text{DREQ}}$ in block transfer mode.

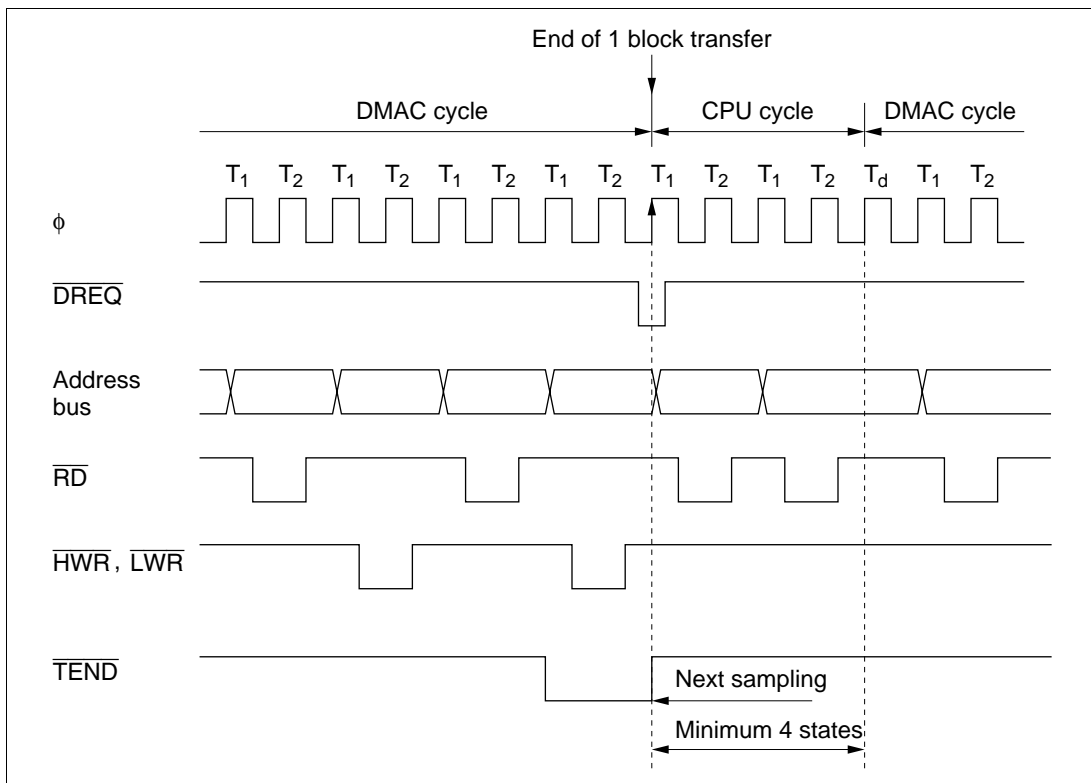

Figure 7.18 Timing of DMAC Activation by Falling Edge of $\overline{\text{DREQ}}$ in Block Transfer Mode

7.4.9 Multiple-Channel Operation

The DMAC channel priority order is: channel 0 > channel 1 and channel A > channel B.

Table 7.12 shows the complete priority order.

Table 7.12 Channel Priority Order

Short Address Mode	Full Address Mode	Priority
Channel 0A	Channel 0	High
Channel 0B		↑
Channel 1A	Channel 1	↓
Channel 1B		Low

If transfers are requested on two or more channels simultaneously, or if a transfer on one channel is requested during a transfer on another channel, the DMAC operates as follows.

- When a transfer is requested, the DMAC requests the bus right. When it gets the bus right, it starts a transfer on the highest-priority channel at that time.
- Once a transfer starts on one channel, requests to other channels are held pending until that channel releases the bus.
- After each transfer in short address mode, and each externally-requested or cycle-steal transfer in normal mode, the DMAC releases the bus and returns to step 1. After releasing the bus, if there is a transfer request for another channel, the DMAC requests the bus again.
- After completion of a burst-mode transfer, or after transfer of one block in block transfer mode, the DMAC releases the bus and returns to step 1. If there is a transfer request for a higher-priority channel or a bus request from a higher-priority bus master, however, the DMAC releases the bus after completing the transfer of the current byte or word. After releasing the bus, if there is a transfer request for another channel, the DMAC requests the bus again.

Figure 7.19 shows the timing when channel 0A is set up for I/O mode and channel 1 for burst mode, and a transfer request for channel 0A is received while channel 1 is active.

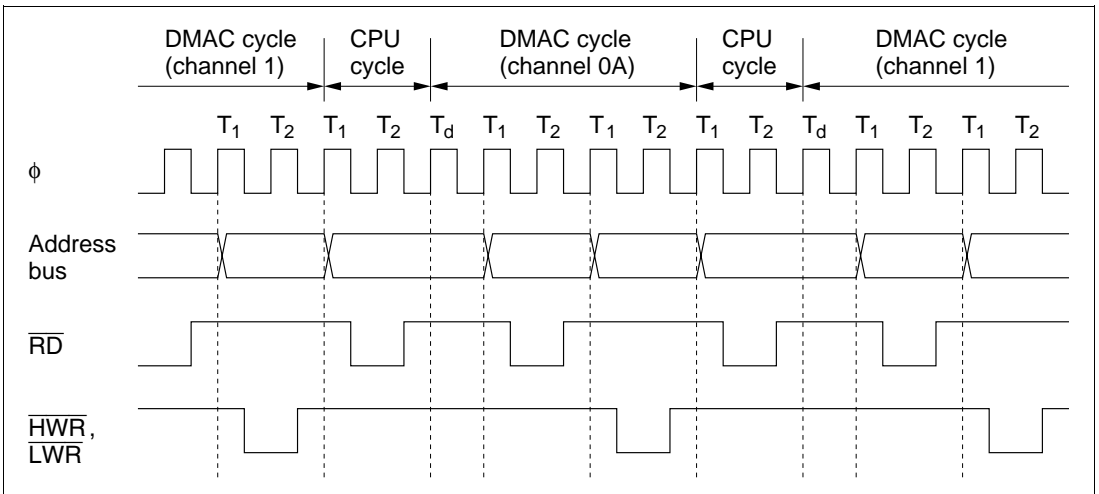

Figure 7.19 Timing of Multiple-Channel Operations

7.4.10 External Bus Requests, DRAM Interface, and DMAC

During a DMAC transfer, if the bus right is requested by an external bus request signal (\overline{BREQ}) or by the DRAM interface (refresh cycle), the DMAC releases the bus after completing the transfer of the current byte or word. If there is a transfer request at this point, the DMAC requests the bus right again. Figure 7.20 shows an example of the timing of insertion of a refresh cycle during a burst transfer on channel 0.

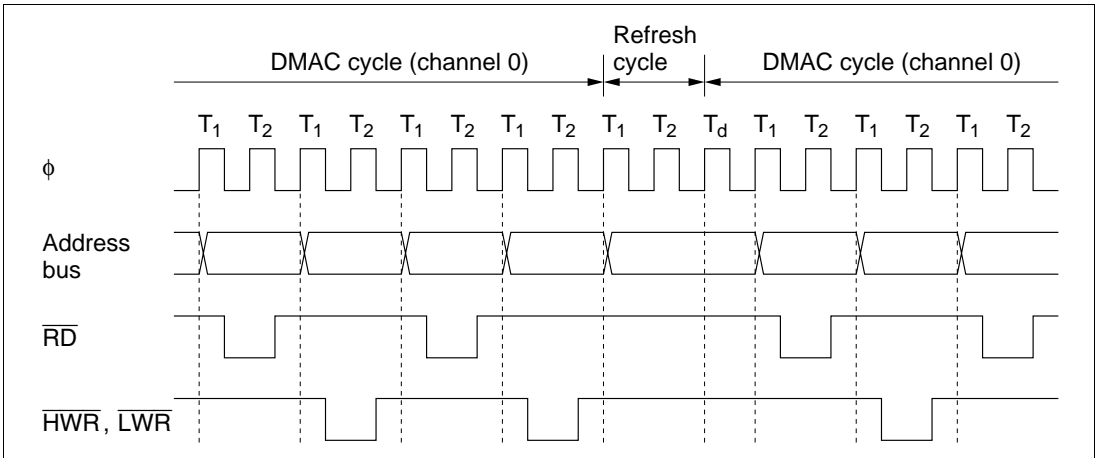

Figure 7.20 Bus Timing of DRAM Interface, and DMAC

7.4.11 NMI Interrupts and DMAC

NMI interrupts do not affect DMAC operations in short address mode.

If an NMI interrupt occurs during a transfer in full address mode, the DMAC suspends operations. In full address mode, a channel is enabled when its DTE and DTME bits are both set to 1. NMI input clears the DTME bit to 0. After transferring the current byte or word, the DMAC releases the bus to the CPU. In normal mode, the suspended transfer resumes when the CPU sets the DTME bit to 1 again. Check that the DTE bit is set to 1 and the DTME bit is cleared to 0 before setting the DTME bit to 1.

Figure 7.21 shows the procedure for resuming a DMAC transfer in normal mode on channel 0 after the transfer was halted by NMI input.

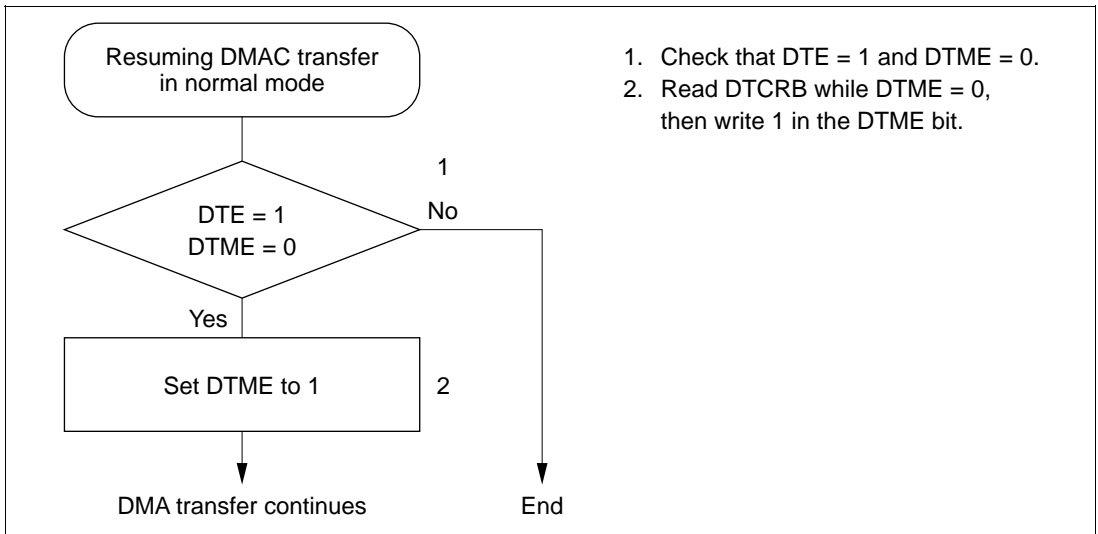

Figure 7.21 Procedure for Resuming a DMAC Transfer Halted by NMI (Example)

For information about NMI interrupts in block transfer mode, see section 7.6.6, NMI Interrupts and Block Transfer Mode.

7.4.12 Aborting a DMAC Transfer

When the DTE bit in an active channel is cleared to 0, the DMAC halts after transferring the current byte or word. The DMAC starts again when the DTE bit is set to 1. In full address mode, the DTME bit can be used for the same purpose. Figure 7.22 shows the procedure for aborting a DMAC transfer by software.

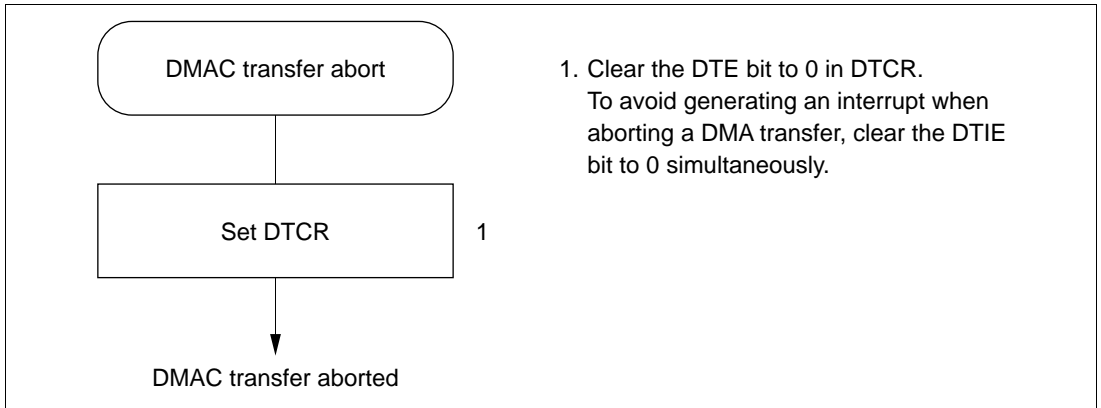

Figure 7.22 Procedure for Aborting a DMAC Transfer

7.4.13 Exiting Full Address Mode

Figure 7.23 shows the procedure for exiting full address mode and initializing the pair of channels. To set the channels up in another mode after exiting full address mode, follow the setup procedure for the relevant mode.

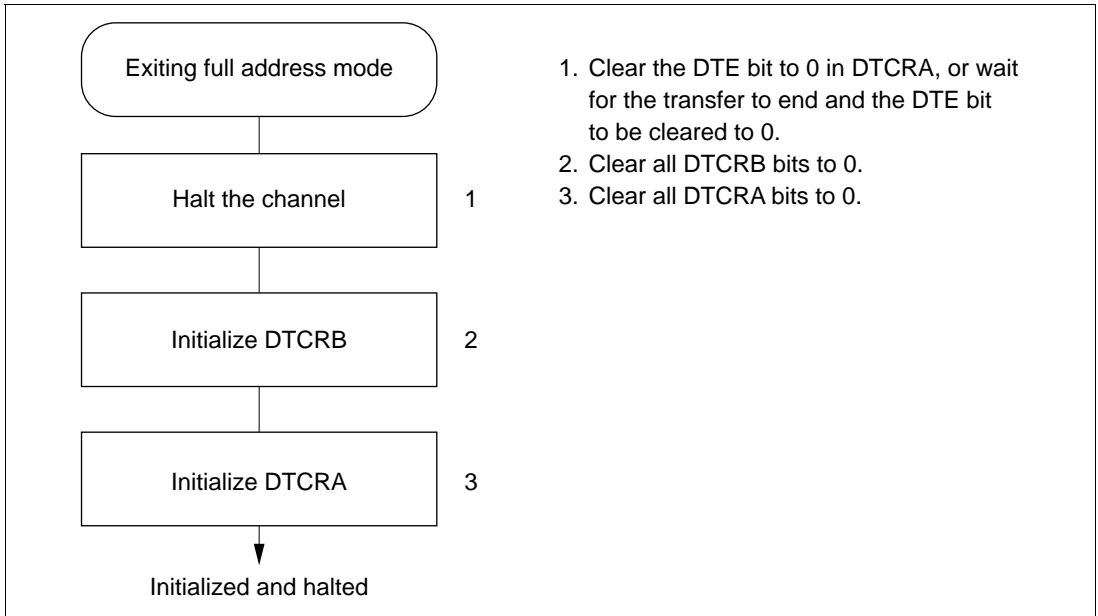

Figure 7.23 Procedure for Exiting Full Address Mode (Example)

7.4.14 DMAC States in Reset State, Standby Modes, and Sleep Mode

When the chip is reset or enters hardware standby mode or software standby mode, the DMAC is initialized and halts. DMAC operations continue in sleep mode. Figure 7.24 shows the timing of a cycle-steal transfer in sleep mode.

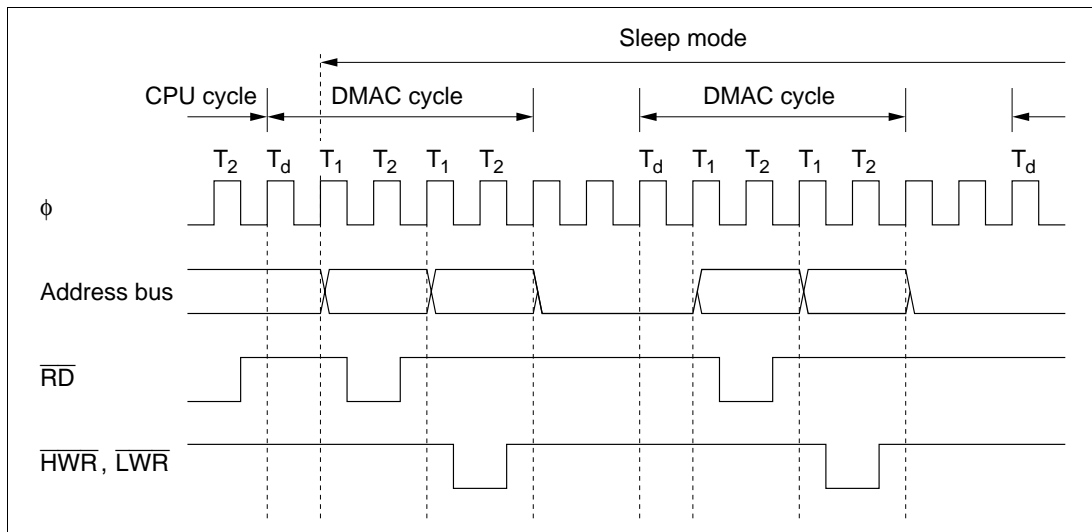

Figure 7.24 Timing of Cycle-Steal Transfer in Sleep Mode

7.5 Interrupts

The DMAC generates only DMA-end interrupts. Table 7.13 lists the interrupts and their priority.

Table 7.13 DMAC Interrupts

Interrupt	Description		Interrupt Priority
	Short Address Mode	Full Address Mode	
DEND0A	End of transfer on channel 0A	End of transfer on channel 0	High
DEND0B	End of transfer on channel 0B	—	↑
DEND1A	End of transfer on channel 1A	End of transfer on channel 1	
DEND1B	End of transfer on channel 1B	—	Low

Each interrupt is enabled or disabled by the DTIE bit in the corresponding data transfer control register (DTCR). Separate interrupt signals are sent to the interrupt controller.

The interrupt priority order among channels is channel 0 > channel 1 and channel A > channel B.

Figure 7.25 shows the DMA-end interrupt logic. An interrupt is requested whenever $DTE = 0$ and $DTIE = 1$.

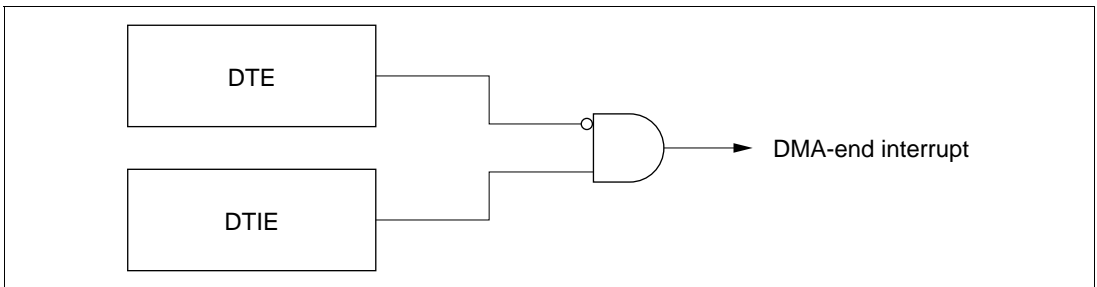

Figure 7.25 DMA-End Interrupt Logic

The DMA-end interrupt for the B channels (DENDB) is unavailable in full address mode. The DTME bit does not affect interrupt operations.

7.6 Usage Notes

7.6.1 Note on Word Data Transfer

Word data cannot be accessed starting at an odd address. When word-size transfer is selected, set even values in the memory and I/O address registers (MAR and IOAR).

7.6.2 DMAC Self-Access

The DMAC itself cannot be accessed during a DMAC cycle. DMAC registers cannot be specified as source or destination addresses.

7.6.3 Longword Access to Memory Address Registers

A memory address register can be accessed as longword data at the MARR address.

Example

```
MOV.L #LBL, ERO
MOV.L ERO, @MARR
```

Four byte accesses are performed. Note that the CPU may release the bus between the second byte (MARE) and third byte (MARH).

Memory address registers should be written and read only when the DMAC is halted.

7.6.4 Note on Full Address Mode Setup

Full address mode is controlled by two registers: DTCRA and DTCRB. Care must be taken to prevent the B channel from operating in short address mode during the register setup. The enable bits (DTE and DTME) should not be set to 1 until the end of the setup procedure.

7.6.5 Note on Activating DMAC by Internal Interrupts

When using an internal interrupt to activate the DMAC, make sure that the interrupt selected as the activating source does not occur during the interval after it has been selected but before the DMAC has been enabled. The on-chip supporting module that will generate the interrupt should not be activated until the DMAC has been enabled. If the DMAC must be enabled while the on-chip supporting module is active, follow the procedure in figure 7.26.

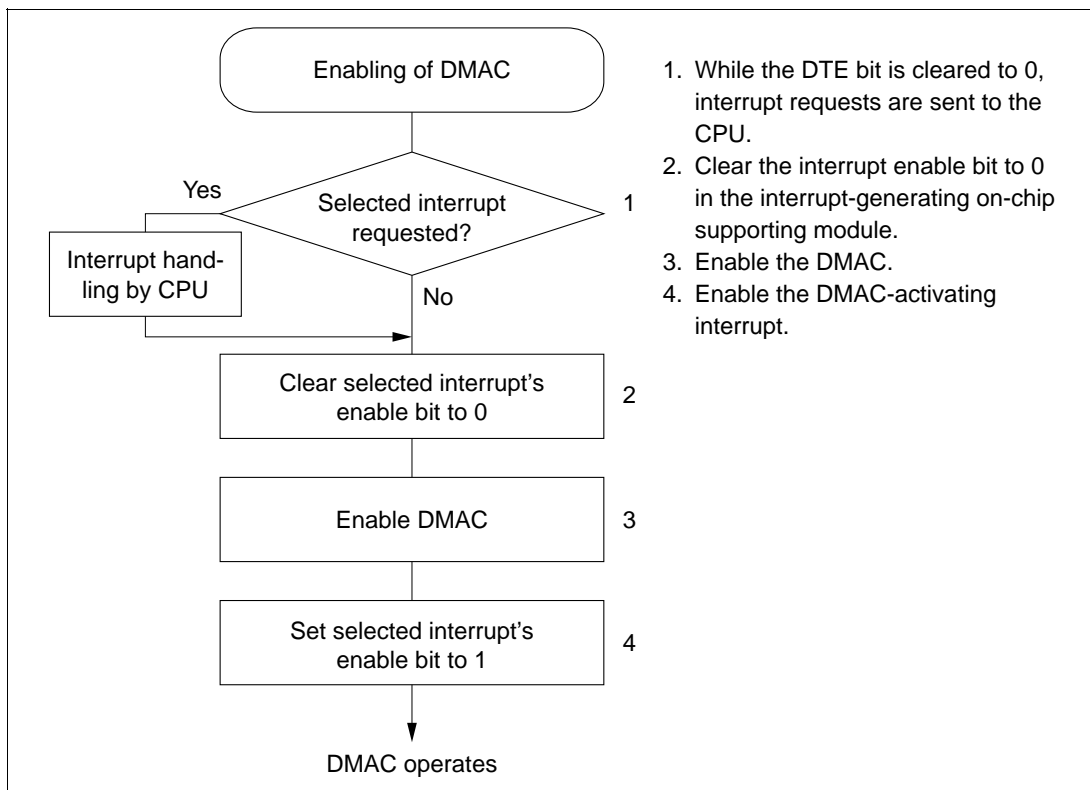

Figure 7.26 Procedure for Enabling DMAC while On-Chip Supporting Module is Operating (Example)

If the DTE bit is set to 1 but the DTME bit is cleared to 0, the DMAC is halted and the selected activating source cannot generate a CPU interrupt. If the DMAC is halted by an NMI interrupt, for example, the selected activating source cannot generate CPU interrupts. To terminate DMAC operations in this state, clear the DTE bit to 0 to allow CPU interrupts to be requested. To continue DMAC operations, carry out steps 2 and 4 in figure 7.26 before and after setting the DTME bit to 1.

When an ITU interrupt activates the DMAC, make sure the next interrupt does not occur before the DMA transfer ends. If one 16-bit timer interrupt activates two or more channels, make sure the next interrupt does not occur before the DMA transfers end on all the activated channels. If the next interrupt occurs before a transfer ends, the channel or channels for which that interrupt was selected may fail to accept further activation requests.

7.6.6 NMI Interrupts and Block Transfer Mode

If an NMI interrupt occurs in block transfer mode, the DMAC operates as follows.

- When the NMI interrupt occurs, the DMAC finishes transferring the current byte or word, then clears the DTME bit to 0 and halts. The halt may occur in the middle of a block.
It is possible to find whether a transfer was halted in the middle of a block by checking the block size counter. If the block size counter does not have its initial value, the transfer was halted in the middle of a block.
- If the transfer is halted in the middle of a block, the activating interrupt flag is cleared to 0. The activation request is not held pending.
- While the DTE bit is set to 1 and the DTME bit is cleared to 0, the DMAC is halted and does not accept activating interrupt requests. If an activating interrupt occurs in this state, the DMAC does not operate and does not hold the transfer request pending internally. Neither is a CPU interrupt requested.

For this reason, before setting the DTME bit to 1, first clear the enable bit of the activating interrupt to 0. Then, after setting the DTME bit to 1, set the interrupt enable bit to 1 again. See section 7.6.5, Note on Activating DMAC by Internal Interrupts.

- When the DTME bit is set to 1, the DMAC waits for the next transfer request. If it was halted in the middle of a block transfer, the rest of the block is transferred when the next transfer request occurs. Otherwise, the next block is transferred when the next transfer request occurs.

7.6.7 Memory and I/O Address Register Values

Table 7.14 indicates the address ranges that can be specified in the memory and I/O address registers (MAR and IOAR).

Table 7.14 Address Ranges Specifiable in MAR and IOAR

	1-Mbyte Mode	16-Mbyte Mode
MAR	H'00000 to H'FFFFFF (0 to 1048575)	H'000000 to H'FFFFFFF (0 to 16777215)
IOAR	H'FFF00 to H'FFFFF (1048320 to 1048575)	H'FFFF00 to H'FFFFFFF (16776960 to 16777215)

MAR bits 23 to 20 are ignored in 1-Mbyte mode.

7.6.8 Bus Cycle when Transfer is Aborted

When a transfer is aborted by clearing the DTE bit or suspended by an NMI that clears the DTME bit, if this halts a channel for which the DMAC has a transfer request pending internally, a dead cycle may occur. This dead cycle does not update the halted channel's address register or counter value. Figure 7.27 shows an example in which an auto-requested transfer in cycle-steal mode on channel 0 is aborted by clearing the DTE bit in channel 0.

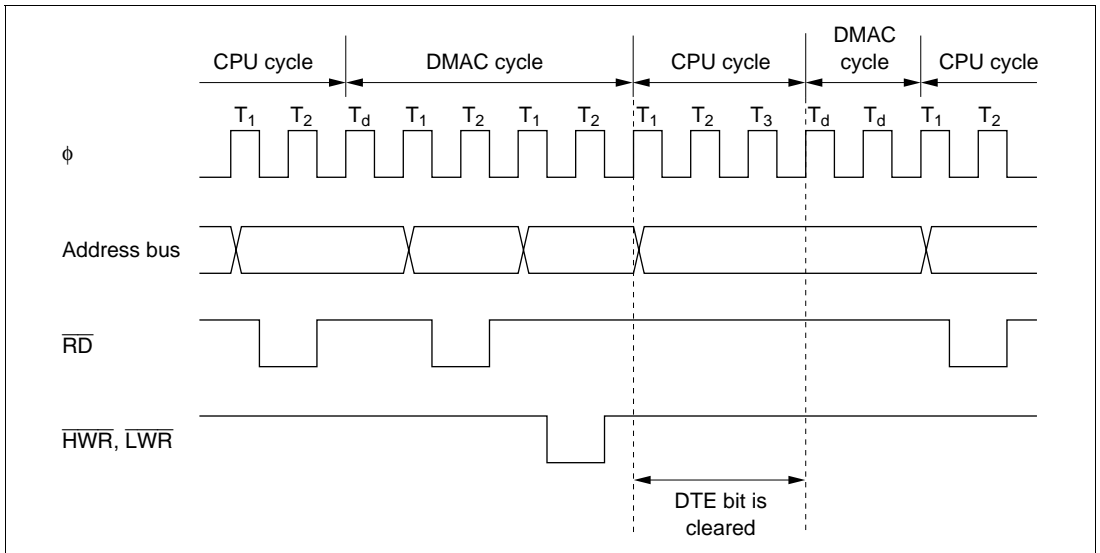

Figure 7.27 Bus Timing at Abort of DMA Transfer in Cycle-Steal Mode

7.6.9 Transfer Requests by A/D Converter

When the A/D converter is set to scan mode and conversion is performed on more than one channel, the A/D converter generates a transfer request when all conversions are completed. The converted data is stored in the appropriate ADDR registers. Block transfer mode and full address mode should therefore be used to transfer all the conversion results at one time.

Section 8 I/O Ports

8.1 Overview

The H8/3006 and H8/3007 have 6 input/output ports (ports 4, 6, 8, 9, A, and B) and one input-only port (port 7). Table 8.1 summarizes the port functions. The pins in each port are multiplexed as shown in table 8.1.

Each port has a data direction register (DDR) for selecting input or output, and a data register (DR) for storing output data. In addition to these registers, port 4 has an input pull-up control register (PCR) for switching input pull-up transistors on and off.

Ports 4, 6, and 8 can drive one TTL load and a 90-pF capacitive load. Ports 9, A, and B can drive one TTL load and a 30-pF capacitive load. Ports 4, 6 and 8 to B can drive a darlington transistor pair. Pins P8₂ to P8₀, PA₇ to PA₀ have Schmitt-trigger input circuits.

For block diagrams of the ports see appendix C, I/O Port Block Diagrams.

Table 8.1 Port Functions

Port	Description	Pins	Mode 1	Mode 2	Mode 3	Mode 4
Port 4	<ul style="list-style-type: none"> 8-bit I/O port Built-in input pull-up transistors 	P4 ₇ to P4 ₀ / D ₇ to D ₀	Data input/output (D ₇ to D ₀) and 8-bit generic input/output	8-bit bus mode: generic input/output	16-bit bus mode: data input/output	
Port 6	<ul style="list-style-type: none"> 4-bit I/O port 	P6 ₇ /φ P6 ₂ / $\overline{\text{BACK}}$ P6 ₁ / $\overline{\text{BREQ}}$ P6 ₀ / $\overline{\text{WAIT}}$	Clock output (φ) and generic input	Bus control signal input/output ($\overline{\text{BACK}}$, $\overline{\text{BREQ}}$, $\overline{\text{WAIT}}$) and 3-bit generic input/output		
Port 7	<ul style="list-style-type: none"> 8-bit I/O port 	P7 ₇ / $\overline{\text{AN}}_7$ / $\overline{\text{DA}}_1$ P7 ₆ / $\overline{\text{AN}}_6$ / $\overline{\text{DA}}_0$ P7 ₅ to P7 ₀ / $\overline{\text{AN}}_5$ to $\overline{\text{AN}}_0$	Analog input ($\overline{\text{AN}}_7$, $\overline{\text{AN}}_6$) to A/D converter, analog output ($\overline{\text{DA}}_1$, $\overline{\text{DA}}_0$) from D/A converter, and generic input	Analog input ($\overline{\text{AN}}_5$ to $\overline{\text{AN}}_0$) to A/D converter, and generic input		
Port 8	<ul style="list-style-type: none"> 5-bit I/O port P8₂ to P8₀ have Schmitt inputs 	P8 ₄ / $\overline{\text{CS}}_0$ P8 ₃ / $\overline{\text{IRQ}}_3$ / $\overline{\text{CS}}_1$ / $\overline{\text{ADTRG}}$ P8 ₂ / $\overline{\text{IRQ}}_2$ / $\overline{\text{CS}}_2$ P8 ₁ / $\overline{\text{IRQ}}_1$ / $\overline{\text{CS}}_3$ P8 ₀ / $\overline{\text{IRQ}}_0$ / $\overline{\text{RFSH}}$	DDR = 0: generic input DDR = 1 (reset value): $\overline{\text{CS}}_0$ output	$\overline{\text{IRQ}}_3$ input, $\overline{\text{CS}}_1$ output, external trigger input ($\overline{\text{ADTRG}}$) to A/D converter, and generic input DDR = 0 (reset value): generic input DDR = 1: $\overline{\text{CS}}_1$ output	$\overline{\text{IRQ}}_2$ and $\overline{\text{IRQ}}_1$ input, $\overline{\text{CS}}_2$ and $\overline{\text{CS}}_3$ output, and generic input DDR = 0 (reset value): generic input DDR = 1: $\overline{\text{CS}}_2$ and $\overline{\text{CS}}_3$ output	$\overline{\text{IRQ}}_0$ input, $\overline{\text{RFSH}}$ output, and generic input/output
Port 9	<ul style="list-style-type: none"> 6-bit I/O port 	P9 ₅ / $\overline{\text{IRQ}}_5$ / $\overline{\text{SCK}}_1$ P9 ₄ / $\overline{\text{IRQ}}_4$ / $\overline{\text{SCK}}_0$ P9 ₃ / $\overline{\text{RxD}}_1$ P9 ₂ / $\overline{\text{RxD}}_0$ P9 ₁ / $\overline{\text{TxD}}_1$ P9 ₀ / $\overline{\text{TxD}}_0$	Input and output ($\overline{\text{SCK}}_1$, $\overline{\text{SCK}}_0$, $\overline{\text{RxD}}_1$, $\overline{\text{RxD}}_0$, $\overline{\text{TxD}}_1$, $\overline{\text{TxD}}_0$) for serial communication interfaces 1 and 0 (SCI1/0), $\overline{\text{IRQ}}_5$ and $\overline{\text{IRQ}}_4$ input, and 6-bit generic input/output			

Port	Description	Pins	Mode 1	Mode 2	Mode 3	Mode 4
Port A	<ul style="list-style-type: none"> 8-bit I/O port Schmitt inputs 	PA ₇ /TP ₇ /TIOCB ₂ / A ₂₀	Output (TP ₇) from programmable timing pattern controller (TPC), input or output (TIOCB ₂) for 16-bit timer and generic input/output		Address output (A ₂₀)	
		PA ₆ /TP ₆ /TIOCA ₂ / A ₂₁ PA ₅ /TP ₅ /TIOCB ₁ / A ₂₂ PA ₄ /TP ₄ /TIOCA ₁ / A ₂₃	TPC output (TP ₆ to TP ₄), 16-bit timer input and output (TIOCA ₂ , TIOCB ₁ , TIOCA ₁), and generic input/output	TPC output (TP ₆ to TP ₄), 16-bit timer input and output (TIOCA ₂ , TIOCB ₁ , TIOCA ₁), address output (A ₂₃ to A ₂₁), and generic input/output		
		PA ₃ /TP ₃ /TIOCB ₀ / TCLKD PA ₂ /TP ₂ /TIOCA ₀ / TCLKC PA ₁ /TP ₁ /TCLKB/ TEND ₁ PA ₀ /TP ₀ /TCLKA/ TEND ₀	TPC output (TP ₃ to TP ₀), 16-bit timer input and output (TIOCB ₀ , TIOCA ₀ , TCLKD, TCLKC, TCLKB, TCLKA), 8-bit timer input (TCLKD, TCLKC, TCLKB, TCLKA), output (TEND ₁ , TEND ₀) from DMA controller (DMAC), and generic input/output			
Port B	<ul style="list-style-type: none"> 8-bit I/O port 	PB ₇ /TP ₁₅ /RXD ₂ PB ₆ /TP ₁₄ /TXD ₂ PB ₅ /TP ₁₃ /SCK ₂ / LCAS PB ₄ /TP ₁₂ /UCAS	TPC output (TP ₁₅ to TP ₁₂), SCI2 input and output (SCK ₂ , RxD ₂ , TxD ₂), DRAM interface output (LCAS, UCAS), and generic input/output			
		PB ₃ /TP ₁₁ /TMIO ₃ / DREQ ₁ /CS ₄ PB ₂ /TP ₁₀ /TMO ₂ / CS ₅ PB ₁ /TP ₉ /TMIO ₁ / DREQ ₀ /CS ₆ PB ₀ /TP ₈ /TMO ₀ / CS ₇	TPC output (TP ₁₁ to TP ₈), 8-bit timer input and output (TMIO ₃ , TMO ₂ , TMIO ₁ , TMO ₀), DMAC input (DREQ ₁ , DREQ ₀), CS ₇ to CS ₄ output, and generic input/output			

8.2 Port 4

8.2.1 Overview

Port 4 is an 8-bit input/output port with the pin configuration shown in figure 8.1.

When the bus width control register (ABWCR) designates areas 0 to 7 all as 8-bit-access areas, the chip operates in 8-bit bus mode and port 4 is a generic input/output port. When at least one of areas 0 to 7 is designated as a 16-bit-access area, the chip operates in 16-bit bus mode and port 4 becomes part of the data bus.

Port 4 has software-programmable built-in pull-up transistors.

Pins in port 4 can drive one TTL load and a 90-pF capacitive load. They can also drive a darlington transistor pair.

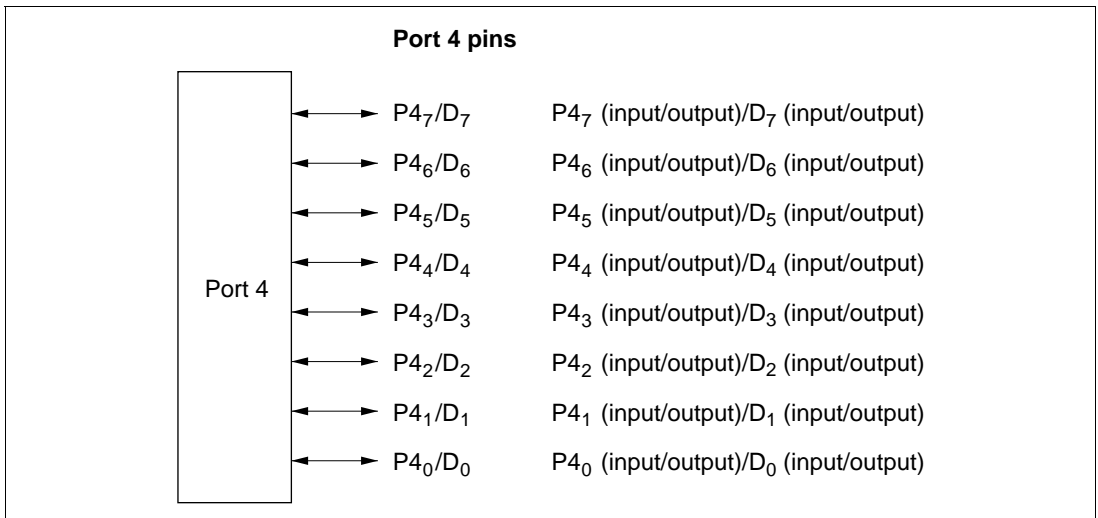

Figure 8.1 Port 4 Pin Configuration

8.2.2 Register Configuration

Table 8.2 summarizes the registers of port 4.

Table 8.2 Port 4 Registers

Address*	Name	Abbreviation	R/W	Initial Value
H'EE003	Port 4 data direction register	P4DDR	W	H'00
H'FFFD3	Port 4 data register	P4DR	R/W	H'00
H'EE03E	Port 4 input pull-up control register	P4PCR	R/W	H'00

Note: * Lower 20 bits of the address in advanced mode.

Port 4 Data Direction Register (P4DDR): P4DDR is an 8-bit write-only register that can select input or output for each pin in port 4.

Bit	7	6	5	4	3	2	1	0
	P4 ₇ DDR	P4 ₆ DDR	P4 ₅ DDR	P4 ₄ DDR	P4 ₃ DDR	P4 ₂ DDR	P4 ₁ DDR	P4 ₀ DDR
Initial value	0	0	0	0	0	0	0	0
Read/Write	W	W	W	W	W	W	W	W

Port 4 data direction 7 to 0

These bits select input or output for port 4 pins

When all areas are designated as 8-bit-access areas by the bus controller's bus width control register (ABWCR), selecting 8-bit bus mode, port 4 functions as an input/output port. In this case, a pin in port 4 becomes an output port if the corresponding P4DDR bit is set to 1, and an input port if this bit is cleared to 0.

When at least one area is designated as a 16-bit-access area, selecting 16-bit bus mode, port 4 functions as part of the data bus, regardless of the P4DDR settings.

P4DDR is initialized to H'00 by a reset and in hardware standby mode. In software standby mode it retains its previous setting.

ABWCR and P4DDR are not initialized in software standby mode. When port 4 functions as a generic input/output port, if a P4DDR bit is set to 1, the corresponding pin maintains its output state in software standby mode.

Port 4 Data Register (P4DR): P4DR is an 8-bit readable/writable register that stores output data for port 4. When port 4 functions as an output port, the value of this register is output. When a bit in P4DDR is set to 1, if port 4 is read the value of the corresponding P4DR bit is returned. When a bit in P4DDR is cleared to 0, if port 4 is read the corresponding pin level is read.

Bit	7	6	5	4	3	2	1	0
	P4 ₇	P4 ₆	P4 ₅	P4 ₄	P4 ₃	P4 ₂	P4 ₁	P4 ₀
Initial value	0	0	0	0	0	0	0	0
Read/Write	R/W	R/W	R/W	R/W	R/W	R/W	R/W	R/W

Port 4 data 7 to 0

These bits store data for port 4 pins

P4DR is initialized to H'00 by a reset and in hardware standby mode. In software standby mode it retains its previous setting.

Port 4 Input Pull-Up MOS Control Register (P4PCR): P4PCR is an 8-bit readable/writable register that controls the MOS input pull-up transistors in port 4.

Bit	7	6	5	4	3	2	1	0
	P4 ₇ PCR	P4 ₆ PCR	P4 ₅ PCR	P4 ₄ PCR	P4 ₃ PCR	P4 ₂ PCR	P4 ₁ PCR	P4 ₀ PCR
Initial value	0	0	0	0	0	0	0	0
Read/Write	R/W	R/W	R/W	R/W	R/W	R/W	R/W	R/W

Port 4 input pull-up control 7 to 0

These bits control input pull-up transistors built into port 4

In 8-bit bus mode when a P4DDR bit is cleared to 0 (selecting generic input), if the corresponding P4PCR bit is set to 1, the input pull-up transistor is turned on.

P4PCR is initialized to H'00 by a reset and in hardware standby mode. In software standby mode it retains its previous setting.

Table 8.3 summarizes the states of the input pull-ups in each operating mode.

Table 8.3 Input Pull-Up Transistor States (Port 4)

Mode	Reset	Hardware Standby Mode	Software Standby Mode	Other Modes
8-bit bus mode	Off	Off	On/off	On/off
16-bit bus mode			Off	Off

Legend

Off: The input pull-up transistor is always off.

On/off: The input pull-up transistor is on if P4PCR = 1 and P4DDR = 0. Otherwise, it is off.

8.3 Port 6

8.3.1 Overview

Port 6 is an 4-bit input/output port that is also used for input and output of bus control signals ($\overline{\text{BACK}}$, $\overline{\text{BREQ}}$, $\overline{\text{WAIT}}$) and for clock (ϕ) output.

The port 6 pin configuration is shown in figure 8.2.

The pin in port 6 functions are P6₇ (generic input)/ ϕ , P6₂/ $\overline{\text{BACK}}$, P6₁/ $\overline{\text{BREQ}}$, and P6₀/ $\overline{\text{WAIT}}$. See table 8.5 for the selection of the pin functions.

See Section 19, Power-Down State, for clock output pin. See Section 6, Bus Controller, for bus control I/O pin ($\overline{\text{BACK}}$, $\overline{\text{BREQ}}$ and $\overline{\text{WAIT}}$).

Pins in port 6 can drive one TTL load and a 90-pF capacitive load. They can also drive a darlington transistor pair.

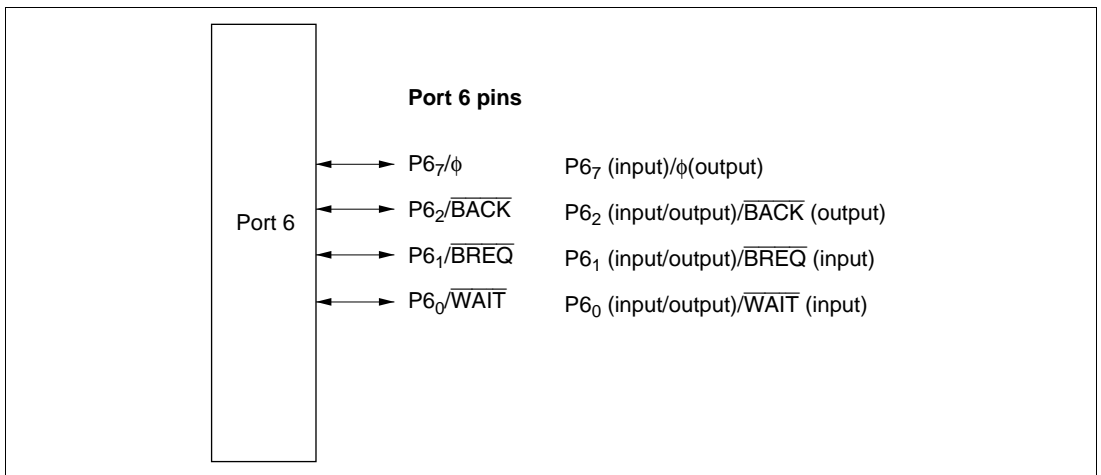

Figure 8.2 Port 6 Pin Configuration

8.3.2 Register Configuration

Table 8.4 summarizes the registers of port 6.

Table 8.4 Port 6 Registers

Address*	Name	Abbreviation	R/W	Initial Value
H'EE005	Port 6 data direction register	P6DDR	W	H'80
H'FFFD5	Port 6 data register	P6DR	R/W	H'80

Note: * Lower 20 bits of the address in advanced mode.

Port 6 Data Direction Register (P6DDR): P6DDR is an 8-bit write-only register that can select input or output for each pin in port 6.

Bits 7 to 3 are reserved. Bit 7 is fixed at 1, and cannot be modified.

Bit	7	6	5	4	3	2	1	0
	—	P6 ₆ DDR	P6 ₅ DDR	P6 ₄ DDR	P6 ₃ DDR	P6 ₂ DDR	P6 ₁ DDR	P6 ₀ DDR
Initial value	1	0	0	0	0	0	0	0
Read/Write	—	W	W	W	W	W	W	W

Reserved bit
Port 6 data direction 2 to 0
These bits select input or output for port 6 pins

P6₇ functions as the clock output pin (ϕ) or an input port. P6₇ is the clock input pin (ϕ) if the PSTOP bit in MSTCRH is cleared to 0 (initial value), and an input port if this bit is set to 1.

When P6₂ to P6₀ function as input/output ports, the pin becomes an output port if the corresponding P6DDR bit is set to 1, and an input port if this bit is cleared to 0.

P6DDR is a write-only register. Its value cannot be read. All bits return 1 when read.

P6DDR is initialized to H'80 by a reset and in hardware standby mode. In software standby mode, it retains its previous setting. When port 6 functions as a generic input/output port, if a P6DDR bit is set to 1, the corresponding pin maintains its output state in software standby mode.

Port 6 Data Register (P6DR): P6DR is an 8-bit readable/writable register that stores output data for port 6. When port 6 functions as an output port, the value of this register is output.

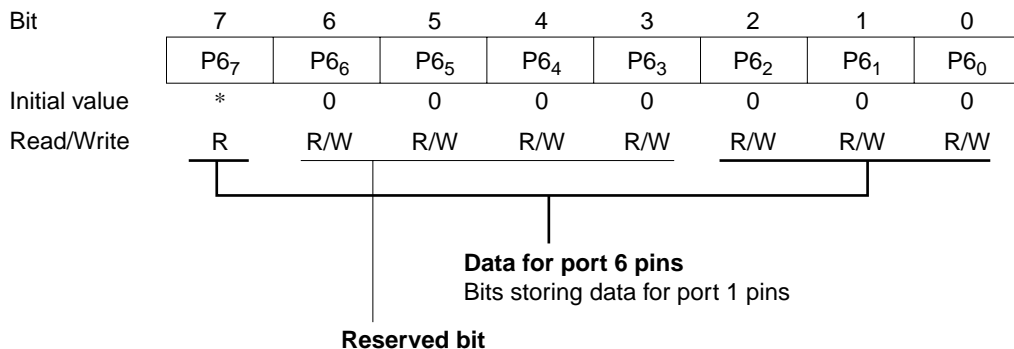

Note: * Determined by pin P6₇.

Bit 7 returns 1 if read when the PSTOP bit in MSTCRH is 0, and returns the logic level of pin P6₇ if read when the PSTOP bit is 1. This bit cannot be modified.

Bits 6 to 3 are reserved; they can be read and written to, but cannot be used as ports.

The P6DR value is returned if P6DR is read while the corresponding bit (P6₆DDR to P6₃DDR) in P6DDR is set to 1, and an undefined value is returned if P6DR is read while the corresponding bit is cleared to 0.

For bits 2 to 0, the pin logic level is returned if the bit is read while the corresponding bit in P6DDR is cleared to 0, and the P6DR value is returned if the bit is read while the corresponding bit in P6DDR is set to 1.

P6DR is initialized to H'80 by a reset and in hardware standby mode. In software standby mode it retains its previous setting.

Table 8.5 Port 6 Pin Functions

Pin	Pin Functions and Selection Method		
P6 ₇ /φ	Bit PSTOP in MSTCRH selects the pin function as follows.		
	PSTOP	0	
	Pin function	φ output	
P6 ₂ /BACK	Bit BRLE in BRCR and bit P6 ₂ DDR select the pin function as follows.		
	BRLE	0	
	P6 ₂ DDR	0	1
Pin function	P6 ₂ input	P6 ₂ output	BACK output
P6 ₁ /BREQ	Bit BRLE in BRCR and bit P6 ₁ DDR select the pin function as follows.		
	BRLE	0	
	P6 ₁ DDR	0	1
Pin function	P6 ₁ input	P6 ₁ output	BREQ input
P6 ₀ /WAIT	Bit WAITE in BCR and bit P6 ₀ DDR select the pin function as follows.		
	WAITE	0	
	P6 ₀ DDR	0	1
Pin function	P6 ₀ input	P6 ₀ output	WAIT input
Note: * Do not set bit P6 ₀ DDR to 1.			

8.4 Port 7

8.4.1 Overview

Port 7 is an 8-bit input-only port that is also used for analog input to the A/D converter and analog output from the D/A converter. The pin functions are the same in all operating modes. Figure 8.3 shows the pin configuration of port 7.

See section 15, A/D Converter, for details of the A/D converter analog input pins, and section 16, D/A Converter, for details of the D/A converter analog output pins.

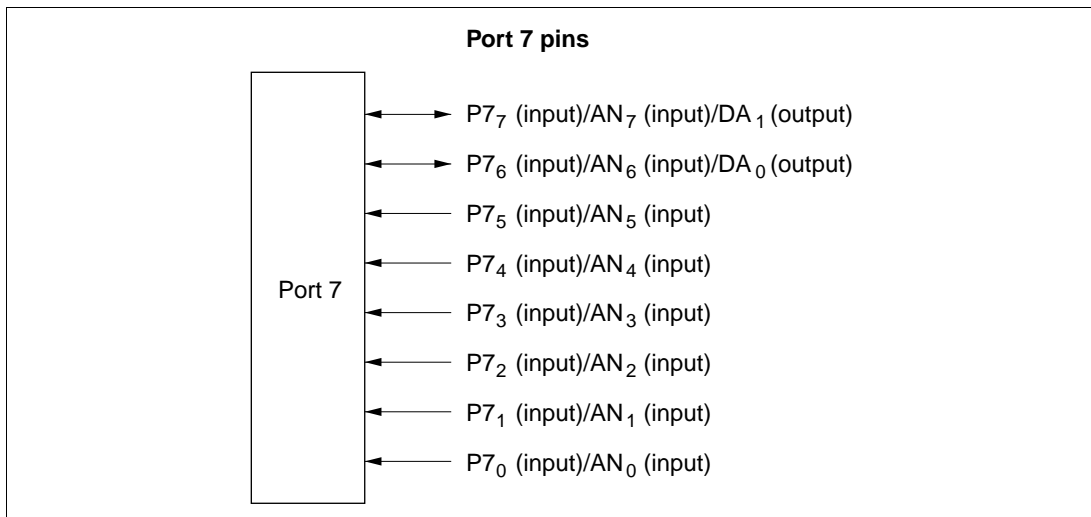

Figure 8.3 Port 7 Pin Configuration

8.4.2 Register Configuration

Table 8.6 summarizes the port 7 register. Port 7 is an input-only port, and so has no data direction register.

Table 8.6 Port 7 Data Register

Address*	Name	Abbreviation	R/W	Initial Value
H'FFFD6	Port 7 data register	P7DR	R	Undetermined

Note: * Lower 20 bits of the address in advanced mode.

Port 7 Data Register (P7DR)

Bit	7	6	5	4	3	2	1	0
	P7 ₇	P7 ₆	P7 ₅	P7 ₄	P7 ₃	P7 ₂	P7 ₁	P7 ₀
Initial value	—*	—*	—*	—*	—*	—*	—*	—*
Read/Write	R	R	R	R	R	R	R	R

Note: * Determined by pins P7₇ to P7₀.

When port 7 is read, the pin levels are always read. P7DR cannot be modified.

8.5 Port 8

8.5.1 Overview

Port 8 is a 5-bit input/output port that is also used for \overline{CS}_3 to \overline{CS}_0 output, \overline{RFSH} output, \overline{IRQ}_3 to \overline{IRQ}_0 input, and A/D converter \overline{ADTRG} input. Figure 8.4 shows the pin configuration of port 8.

See table 8.8 for the selection of pin functions.

See section 15, A/D Converter, for a description of the A/D converter's \overline{ADTRG} input pin.

The \overline{IRQ}_3 to \overline{IRQ}_0 functions are selected by IER settings, regardless of whether the pin is used for input or output. Caution is therefore required. For details see section 5, Interrupt Controller.

When DRAM is connected to areas 2 to 5, the \overline{CS}_3 and \overline{CS}_2 output pins function as \overline{RAS} output pins for each area. For details see section 6.5, DRAM Interface.

Pins in port 8 can drive one TTL load and a 90-pF capacitive load. They can also drive a darlington transistor pair.

Pins P8₂ to P8₀ have Schmitt-trigger inputs.

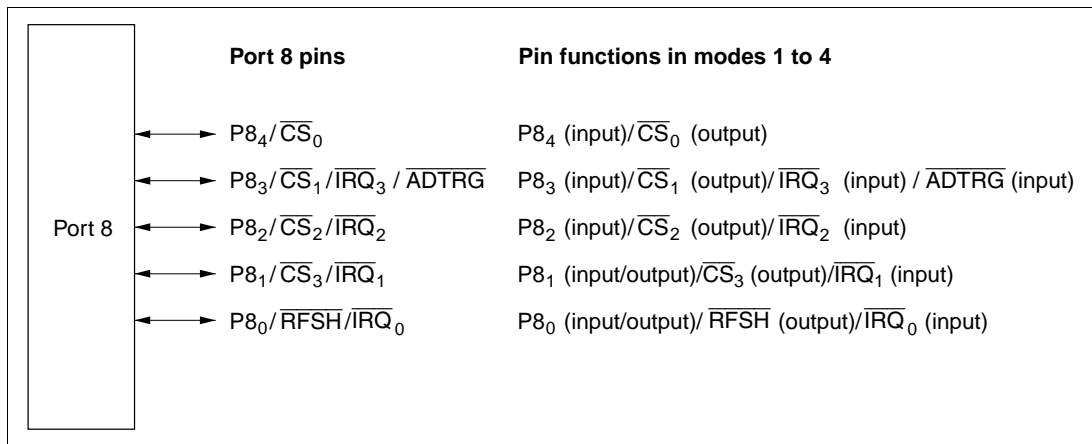

Figure 8.4 Port 8 Pin Configuration

8.5.2 Register Configuration

Table 8.7 summarizes the registers of port 8.

Table 8.7 Port 8 Registers

Address*	Name	Abbreviation	R/W	Initial Value
				Mode 1 to 4
H'EE007	Port 8 data direction register	P8DDR	W	H'F0
H'FFFD7	Port 8 data register	P8DR	R/W	H'E0

Note: * Lower 20 bits of the address in advanced mode.

Port 8 Data Direction Register (P8DDR): P8DDR is an 8-bit write-only register that can select input or output for each pin in port 8.

Bits 7 to 5 are reserved. They are fixed at 1, and cannot be modified.

Bit	7	6	5	4	3	2	1	0
	—	—	—	P8 ₄ DDR	P8 ₃ DDR	P8 ₂ DDR	P8 ₁ DDR	P8 ₀ DDR
Modes 1 to 4 {	Initial value	1	1	1	1	0	0	0
	Read/Write	—	—	—	W	W	W	W

Reserved bits
Port 8 data direction 4 to 0
These bits select input or output for port 8 pins

When bits in P8DDR bit are set to 1, P8₄ to P8₁ become \overline{CS}_0 to \overline{CS}_3 output pins. When bits in P8DDR are cleared to 0, the corresponding pins become input ports. Following a reset P8₄ functions as the \overline{CS}_0 output, while the other three pins are input ports.

When the refresh enable bit (RFSHE) in DRCRA is set to 1, P8₀ is used for \overline{RFSH} output. When RFSHE is cleared to 0, P8₀ becomes an input/output port according to the P8DDR setting. For details see table 8.8.

P8DDR is a write-only register. Its value cannot be read. All bits return 1 when read.

P8DDR is initialized to H'F0 by a reset and in hardware standby mode. In software standby mode P8DDR retains its previous setting. Therefore, when port 8 functions as an input/output port, if a transition is made to software standby mode while a P8DDR bit is set to 1, the corresponding pin maintains its output state.

Port 8 Data Register (P8DR): P8DR is an 8-bit readable/writable register that stores output data for port 8. When a bit in P8DDR is set to 1, if port 8 is read the value of the corresponding P8DR bit is returned. When a bit in P8DDR is cleared to 0, if port 8 is read the corresponding pin level is read.

Bits 7 to 5 are reserved. They cannot be modified and always are read as 1.

Bit	7	6	5	4	3	2	1	0
	—	—	—	P8 ₄	P8 ₃	P8 ₂	P8 ₁	P8 ₀
Initial value	1	1	1	0	0	0	0	0
Read/Write	—	—	—	R/W	R/W	R/W	R/W	R/W

Reserved bits
Port 8 data 4 to 0
These bits store data for port 8 pins

P8DR is initialized to H'E0 by a reset and in hardware standby mode. In software standby mode it retains its previous setting.

Table 8.8 Port 8 Pin Functions
Pin Pin Functions and Selection Method
 $P8_4/\overline{CS}_0$

 Bit P8₄DDR selects the pin function as follows.

P8 ₄ DDR	0	1
Pin function	P8 ₄ input	\overline{CS}_0 output

 $P8_3/\overline{CS}_1/\overline{IRQ}_3/\overline{ADTRG}$

 Bit P8₃DDR selects the pin function as follows

P8 ₃ DDR	0	1
Pin function	P8 ₃ input	\overline{CS}_1 output
	\overline{IRQ}_3 input	
	\overline{ADTRG} input	

 $P8_2/\overline{CS}_2/\overline{IRQ}_2$

 The DRAM interface settings by bits DRAS2 to DRAS0 in DRCRA, and bit P8₂DDR, select the pin function as follows.

DRAM interface settings	(1) in table below		(2) in table below
P8 ₂ DDR	0	1	—
Pin function	P8 ₂ input	\overline{CS}_2 output	\overline{CS}_2 output*
	\overline{IRQ}_3 input		

 Note: * \overline{CS}_2 is output as \overline{RAS}_2

DRAM interface setting	(1)	(2)						
DRAS2	0			1				
DRAS1	0	1		0	1			
DRAS0	0	1	0	1	0	1	0	1

 $P8_1/\overline{CS}_3/\overline{IRQ}_1$

 The DRAM interface settings by bits DRAS2 to DRAS0 in DRCRA, and bit P8₁DDR, select the pin function as follows.

DRAM interface settings	(1) in table below		(2) in table below		(3) in table below
P8 ₁ DDR	0	1	0	1	—
Pin function	P8 ₁ input	\overline{CS}_3 output	P8 ₁ input	P8 ₁ output	\overline{CS}_3 output*
	\overline{IRQ}_1 input				

 Note: * \overline{CS}_3 is output as \overline{RAS}_3

DRAM interface setting	(1)	(3)	(2)	(3)	(2)	
DRAS2	0			1		
DRAS1	0	1		0	1	
DRAS0	0	1	0	1	0	1

 $P8_0/\overline{RFSH}/\overline{IRQ}_0$

 Bit RFSHE in DRCRA and bit P8₀DDR select the pin function as follows. If areas 2 to 5 are not designated as DRAM space, do not set bit RFSHE in DRCRA to 1.

RFSHE	0		1
P8 ₀ DDR	0	1	—
Pin function	P8 ₀ input	P8 ₀ output	\overline{RFSH} output
	\overline{IRQ}_0 input		

8.6 Port 9

8.6.1 Overview

Port 9 is a 6-bit input/output port that is also used for input and output (TxD₀, TxD₁, RxD₀, RxD₁, SCK₀, SCK₁) by serial communication interface channels 0 and 1 (SCI0 and SCI1), and for $\overline{\text{IRQ}}_5$ and $\overline{\text{IRQ}}_4$ input. See table 8.10 for the selection of pin functions.

The $\overline{\text{IRQ}}_5$ and $\overline{\text{IRQ}}_4$ functions are selected by IER settings, regardless of whether the pin is used for input or output. Caution is therefore required. For details see section 5.3.1, External Interrupts.

Port 9 has the same set of pin functions in all operating modes. Figure 8.5 shows the pin configuration of port 9.

Pins in port 9 can drive one TTL load and a 30-pF capacitive load. They can also drive a darlington transistor pair.

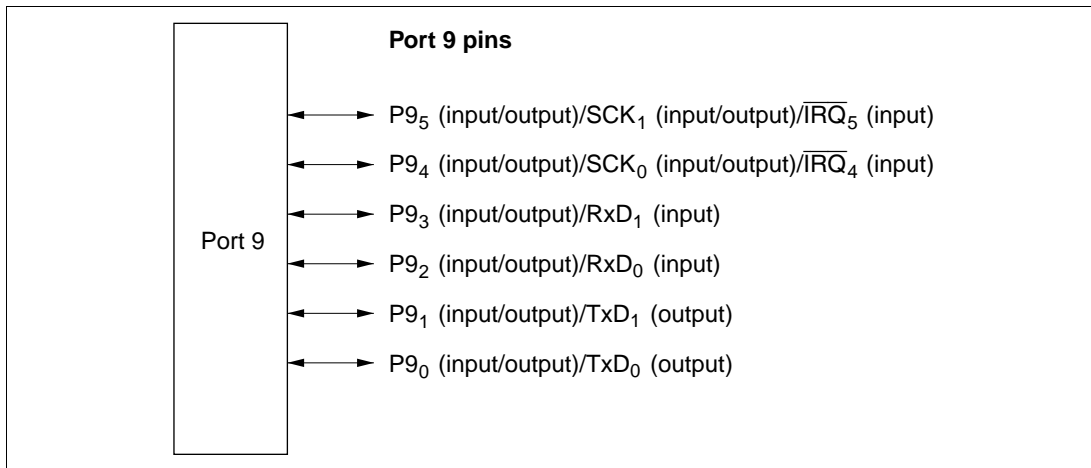

Figure 8.5 Port 9 Pin Configuration

8.6.2 Register Configuration

Table 8.9 summarizes the registers of port 9.

Table 8.9 Port 9 Registers

Address*	Name	Abbreviation	R/W	Initial Value
H'EE008	Port 9 data direction register	P9DDR	W	H'C0
H'FFFD8	Port 9 data register	P9DR	R/W	H'C0

Note: * Lower 20 bits of the address in advanced mode.

Port 9 Data Direction Register (P9DDR): P9DDR is an 8-bit write-only register that can select input or output for each pin in port 9.

Bits 7 and 6 are reserved. They cannot be modified and always read as 1.

Bit	7	6	5	4	3	2	1	0
	—	—	P9 ₅ DDR	P9 ₄ DDR	P9 ₃ DDR	P9 ₂ DDR	P9 ₁ DDR	P9 ₀ DDR
Initial value	1	1	0	0	0	0	0	0
Read/Write	—	—	W	W	W	W	W	W

Reserved bits
Port 9 data direction 5 to 0
These bits select input or output for port 9 pins

When a pin in port 9 becomes an output port if the corresponding P9DDR bit is set to 1, and an input port if this bit is cleared to 0.

P9DDR is a write-only register. Its value cannot be read. All bits return 1 when read.

P9DDR is initialized to H'C0 by a reset and in hardware standby mode. In software standby mode it retains its previous setting. When transition is made to software standby mode while a P9DDR bit is set to 1, the corresponding pin maintains its output state.

Port 9 Data Register (P9DR): P9DR is an 8-bit readable/writable register that stores output data for port 9. When port 9 functions as an output port, the value of this register is output. When a bit in P9DDR is set to 1, if port 9 is read the value of the corresponding P9DR bit is returned. When a bit in P9DDR is cleared to 0, if port 9 is read the corresponding pin level is read.

Bits 7 and 6 are reserved. They cannot be modified and are always read as 1.

Bit	7	6	5	4	3	2	1	0
	—	—	P9 ₅	P9 ₄	P9 ₃	P9 ₂	P9 ₁	P9 ₀
Initial value	1	1	0	0	0	0	0	0
Read/Write	—	—	R/W	R/W	R/W	R/W	R/W	R/W

Reserved bits
Port 9 data 5 to 0
These bits store data for port 9 pins

P9DR is initialized to H'C0 by a reset and in hardware standby mode. In software standby mode it retains its previous setting.

Table 8.10 Port 9 Pin Functions
Pin Pin Functions and Selection Method
P9₇/SCK₇/IRQ₅

 Bit C/ \bar{A} in SMR of SCI1, bits CKE0 and CKE1 in SCR, and bit P9₅DDR select the pin function as follows.

CKE1	0			1
C/ \bar{A}	0		1	—
CKE0	0	1	—	—
P9 ₅ DDR	0	1	—	—
Pin function	P9 ₅ input	P9 ₅ output	SCK ₇ output	SCK ₇ output
	IRQ ₅ input			

P9₆/SCK₆/IRQ₄

 Bit C/ \bar{A} in SMR of SCI0, bits CKE0 and CKE1 in SCR, and bit P9₄DDR select the pin function as follows.

CKE1	0			1
C/ \bar{A}	0		1	—
CKE0	0	1	—	—
P9 ₄ DDR	0	1	—	—
Pin function	P9 ₄ input	P9 ₄ output	SCK ₆ output	SCK ₆ output
	IRQ ₄ input			

P9₅/RxD₁

 Bit RE in SCR of SCI1, bit SMIF in SCMR, and bit P9₃DDR select the pin function as follows.

SMIF	0			1
RE	0		1	—
P9 ₃ DDR	0	1	—	—
Pin function	P9 ₃ input	P9 ₃ output	RxD ₁ input	RxD ₁ input

P9₄/RxD₀

 Bit RE in SCR of SCI0, bit SMIF in SCMR, and bit P9₂DDR select the pin function as follows.

SMIF	0			1
RE	0		1	—
P9 ₂ DDR	0	1	—	—
Pin function	P9 ₂ input	P9 ₂ output	RxD ₀ input	RxD ₀ input

Pin	Pin Functions and Selection Method			
P9 ₇ /TxD ₁	Bit TE in SCR of SCI1, bit SMIF in SCMR, and bit P9 ₁ DDR select the pin function as follows.			
	SMIF	0		1
	TE	0	1	—
	P9 ₁ DDR	0	1	—
	Pin function	P9 ₁ input	P9 ₁ output	TxD ₁ output
Note: * Functions as the TxD ₁ output pin, but there are two states: one in which the pin is driven, and another in which the pin is at high-impedance.				
P9 ₀ /TxD ₀	Bit TE in SCR of SCI0, bit SMIF in SCMR, and bit P9 ₀ DDR select the pin function as follows.			
	SMIF	0		1
	TE	0	1	—
	P9 ₀ DDR	0	1	—
	Pin function	P9 ₀ input	P9 ₀ output	TxD ₀ output
Note: * Functions as the TxD ₀ output pin, but there are two states: one in which the pin is driven, and another in which the pin is at highimpedance.				

8.7 Port A

8.7.1 Overview

Port A is an 8-bit input/output port that is also used for output (TP₇ to TP₀) from the programmable timing pattern controller (TPC), input and output, (TIOCB₂, TIOCA₂, TIOCB₁, TIOCA₁, TIOCB₀, TIOCA₀, TCLKD, TCLKC, TCLKB, TCLKA) by the 16-bit timer, input (TCLKD, TCLKC, TCLKB, TCLKA) to the 8-bit timer, output (TEND₁, TEND₀) from the DMA controller (DMAC), and address output (A₂₃ to A₂₀). A reset or hardware standby transition leaves port A as an input port, except that in modes 3 and 4, one pin is always used for A₂₀ output. See table 8.12 to 8.14 for the selection of pin functions.

Usage of pins for TPC, 16-bit timer, 8-bit timer, and DMAC input and output is described in the sections on those modules. For output of address bits A₂₃ to A₂₁ in modes 3 and 4, see section 6.2.4, Bus Release Control Register (BRCR). Pins not assigned to any of these functions are available for generic input/output. Figure 8.6 shows the pin configuration of port A.

Pins in port A can drive one TTL load and a 30-pF capacitive load. They can also drive a darlington transistor pair. Port A has Schmitt-trigger inputs.

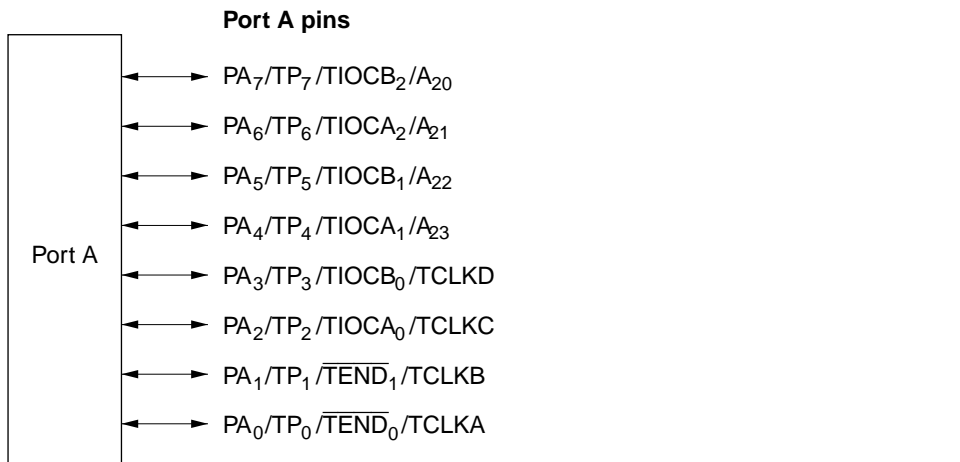

Pin functions in modes 1 and 2

PA₇ (input/output)/TP₇ (output)/TIOCB₂ (input/output)
 PA₆ (input/output)/TP₆ (output)/TIOCA₂ (input/output)
 PA₅ (input/output)/TP₅ (output)/TIOCB₁ (input/output)
 PA₄ (input/output)/TP₄ (output)/TIOCA₁ (input/output)
 PA₃ (input/output)/TP₃ (output)/TIOCB₀ (input/output)/TCLKD (input)
 PA₂ (input/output)/TP₂ (output)/TIOCA₀ (input/output)/TCLKC (input)
 PA₁ (input/output)/TP₁ (output)/ $\overline{\text{TEND}}_1$ (output)/TCLKB (input)
 PA₀ (input/output)/TP₀ (output)/ $\overline{\text{TEND}}_0$ (output)/TCLKA (input)

Pin functions in modes 3 and 4

A₂₀ (output)
 PA₆ (input/output)/TP₆ (output)/TIOCA₂ (input/output)/A₂₁ (output)
 PA₅ (input/output)/TP₅ (output)/TIOCB₁ (input/output)/A₂₂ (output)
 PA₄ (input/output)/TP₄ (output)/TIOCA₁ (input/output)/A₂₃ (output)
 PA₃ (input/output)/TP₃ (output)/TIOCB₀ (input/output)/TCLKD (input)
 PA₂ (input/output)/TP₂ (output)/TIOCA₀ (input/output)/TCLKC (input)
 PA₁ (input/output)/TP₁ (output)/ $\overline{\text{TEND}}_1$ (output)/TCLKB (input)
 PA₀ (input/output)/TP₀ (output)/ $\overline{\text{TEND}}_0$ (output)/TCLKA (input)

Figure 8.6 Port A Pin Configuration

8.7.2 Register Configuration

Table 8.11 summarizes the registers of port A.

Table 8.11 Port A Registers

Address*	Name	Abbreviation	R/W	Initial Value	
				Modes 1, 2	Modes 3, 4
H'EE009	Port A data direction register	PADDR	W	H'00	H'80
H'FFFD9	Port A data register	PADR	R/W	H'00	H'00

Note: * Lower 20 bits of the address in advanced mode.

Port A Data Direction Register (PADDR): PADDR is an 8-bit write-only register that can select input or output for each pin in port A. When pins are used for TPC output, the corresponding PADDR bits must also be set.

Bit		7	6	5	4	3	2	1	0
		PA ₇ DDR	PA ₆ DDR	PA ₅ DDR	PA ₄ DDR	PA ₃ DDR	PA ₂ DDR	PA ₁ DDR	PA ₀ DDR
Modes 3, 4,	Initial value	1	0	0	0	0	0	0	0
	Read/Write	—	W	W	W	W	W	W	W
Modes 1, 2	Initial value	0	0	0	0	0	0	0	0
	Read/Write	W	W	W	W	W	W	W	W

Port A data direction 7 to 0

These bits select input or output for port A pins

A pin in port A becomes an output port if the corresponding PADDR bit is set to 1, and an input port if this bit is cleared to 0. In modes 3 and 4, PA₇DDR is fixed at 1 and PA₇ functions as an address output pin.

PADDR is a write-only register. Its value cannot be read. All bits return 1 when read.

PADDR is initialized to H'00 (modes 1 and 2) or H'80 (modes 3 and 4) by a reset and in hardware standby mode. In software standby mode it retains its previous setting. Therefore, if a transition is made to software standby mode while a PADDR bit is set to 1, the corresponding pin maintains its output state.

Port A Data Register (PADDR): PADDR is an 8-bit readable/writable register that stores output data for port A. When port A functions as an output port, the value of this register is output. When a bit in PADDR is set to 1, if port A is read the value of the corresponding PADDR bit is returned. When a bit in PADDR is cleared to 0, if port A is read the corresponding pin level is read.

Bit	7	6	5	4	3	2	1	0
	PA ₇	PA ₆	PA ₅	PA ₄	PA ₃	PA ₂	PA ₁	PA ₀
Initial value	0	0	0	0	0	0	0	0
Read/Write	R/W	R/W	R/W	R/W	R/W	R/W	R/W	R/W

Port A data 7 to 0

These bits store data for port A pins

PADDR is initialized to H'00 by a reset and in hardware standby mode. In software standby mode it retains its previous setting.

Table 8.12 Port A Pin Functions (Modes 1, 2)

Pin Pin Functions and Selection Method

PA₇/TP₇/
TIOCB₂ Bit PWM2 in TMDR, bits IOB2 to IOB0 in TIOR2, bit NDER7 in NDERA, and bit PA₇DDR select the pin function as follows.

16-bit timer channel 2 settings	(1) in table below	(2) in table below		
PA ₇ DDR	—	0	1	1
NDER7	—	—	0	1
Pin function	TIOCB ₂ output	PA ₇ input	PA ₇ output	TP ₇ output
		TIOCB ₂ input*		

Note: * TIOCB₂ input when IOB2 = 1 and PWM2 = 0.

16-bit timer channel 2 settings	(2)	(1)		(2)
IOB2	0			1
IOB1	0	0	1	—
IOB0	0	1	—	—

Pin Pin Functions and Selection Method

PA₆/TP₆/
TIOCA₂ Bit PWM2 in TMDR, bits IOA2 to IOA0 in TIOR2, bit NDER6 in NDERA, and bit PA₆DDR select the pin function as follows.

16-bit timer channel 2 settings	(1) in table below	(2) in table below		
PA ₆ DDR	—	0	1	1
NDER6	—	—	0	1
Pin function	TIOCA ₂ output	PA ₆ input	PA ₆ output	TP ₆ output
		TIOCA ₂ input*		

Note: * TIOCA₂ input when IOA2 = 1.

16-bit timer channel 2 settings	(2)	(1)		(2)	(1)
PWM2	0				1
IOA2	0			1	—
IOA1	0	0	1	—	—
IOA0	0	1	—	—	—

PA₅/TP₅/
TIOCB₁ Bit PWM1 in TMDR, bits IOB2 to IOB0 in TIOR1, bit NDER5 in NDERA, and bit PA₅DDR select the pin function as follows.

16-bit timer channel 1 settings	(1) in table below	(2) in table below		
PA ₅ DDR	—	0	1	1
NDER5	—	—	0	1
Pin function	TIOCB ₁ output	PA ₅ input	PA ₅ output	TP ₅ output
		TIOCB ₁ input*		

Note: * TIOCB₁ input when IOB2 = 1 and PWM1 = 0.

16-bit timer channel 1 settings	(2)	(1)		(2)
IOB2	0			1
IOB1	0	0	1	—
IOB0	0	1	—	—

Pin Pin Functions and Selection Method

PA_n/TP_n/
TIOCA_n Bit PWM1 in TMDR, bits IOA2 to IOA0 in TIOR1, bit NDER4 in NDERA, and bit PA_nDDR select the pin function as follows.

16-bit timer channel 1 settings	(1) in table below	(2) in table below		
PA _n DDR	—	0	1	1
NDER4	—	—	0	1
Pin function	TIOCA _n output	PA _n input	PA _n output	TP _n output
		TIOCA _n input*		

Note: * TIOCA_n input when IOA2 = 1.

16-bit timer channel 1 settings	(2)	(1)		(2)	(1)
PWM1	0				1
IOA2	0			1	—
IOA1	0	0	1	—	—
IOA0	0	1	—	—	—

Table 8.13 Port A Pin Functions (Modes 3, 4)

Pin	Pin Functions and Selection Method				
PA ₇ /TP ₇ /	Always used as A ₂₀ output.				
TIOCB ₂ /A ₂₀	Pin function	A ₂₀ output			
PA ₆ /TP ₆ /	Bit PWM2 in TMDR, bits IOA2 to IOA0 in TIOR2, bit NDER6 in NDERA, bit A21E in BRCCR, and bit PA ₆ DDR				
TIOCA ₂ /A ₂₁	select the pin function as follows.				
A21E	1				0
16-bit timer channel 2 settings	(1) in table below	(2) in table below			—
PA ₆ DDR	—	0	1	1	—
NDER6	—	—	0	1	—
Pin function	TIOCA ₂ output	PA ₆ input	PA ₆ output	TP ₆ output	A ₂₁ output
		TIOCA ₂ input*			
Note: * TIOCA ₂ input when IOA2 = 1.					
16-bit timer channel 2 settings	(2)	(1)		(2)	(1)
PWM2	0				1
IOA2	0			1	—
IOA1	0	0	1	—	—
IOA0	0	1	—	—	—
PA ₅ /TP ₅ /	Bit PWM1 in TMDR, bits IOB2 to IOB0 in TIOR1, bit NDER5 in NDERA, bit A22E in BRCCR, and bit PA ₅ DDR				
TIOCB ₁ /A ₂₂	select the pin function as follows.				
A22E	1				0
16-bit timer channel 1 settings	(1) in table below	(2) in table below			—
PA ₅ DDR	—	0	1	1	—
NDER5	—	—	0	1	—
Pin function	TIOCB ₁ output	PA ₅ input	PA ₅ output	TP ₅ output	A ₂₂ output
		TIOCB ₁ input*			
Note: * TIOCB ₁ input when IOB2 = 1 and PWM1 = 0.					
16-bit timer channel 1 settings	(2)	(1)		(2)	
IOB2	0			1	
IOB1	0	0	1	—	
IOB0	0	1	—	—	

Pin Pin Functions and Selection Method

PA₄/TP₄/
TIOCA₁/A₂₃ Bit PWM1 in TMDR, bits IOA2 to IOA0 in TIOR1, bit NDER4 in NDERA, bit A23E in BRCCR, and bit PA₄DDR select the pin function as follows.

A23E	1				0
16-bit timer channel 1 settings	(1) in table below	(2) in table below			—
PA ₄ DDR	—	0	1	1	—
NDER4	—	—	0	1	—
Pin function	TIOCA ₁ output	PA ₄ input	PA ₄ output	TP ₄ output	A ₂₃ output
		TIOCA ₁ input*			

Note: * TIOCA₁ input when IOA2 = 1.

16-bit timer channel 1 settings	(2)	(1)		(2)	(1)
PWM1	0				1
IOA2	0			1	—
IOA1	0	0	1	—	—
IOA0	0	1	—	—	—

Table 8.14 Port A Pin Functions (Modes 1 to 4)

Pin Pin Functions and Selection Method

PA₃/TP₃/
TIOCB₀/
TCLKD Bit PWM0 in TMDR, bits IOB2 to IOB0 in TIOR0, bits TPSC2 to TPSC0 in TCR2 to TCR0 of the 16-bit timer, bits CKS2 to CKS0 in TCR3 of the 8-bit timer, bit NDER3 in NDERA, and bit PA₃DDR select the pin function as follows.

16-bit timer channel 0 settings	(1) in table below	(2) in table below		
PA ₃ DDR	—	0	1	1
NDER3	—	—	0	1
Pin function	TIOCB ₀ output	PA ₃ input	PA ₃ output	TP ₃ output
		TIOCB ₀ input* ¹		
		TCLKD input* ²		

- Notes: 1. TIOCB₀ input when IOB2 = 1 and PWM0 = 0.
2. TCLKD input when TPSC2 = TPSC1 = TPSC0 = 1 in any of TCR2 to TCR0, or bits CKS2 to CKS0 in TCR3 are as shown in (3) in the table below.

16-bit timer channel 0 settings	(2)	(1)		(2)
IOB2	0			1
IOB1	0	0	1	—
IOB0	0	1	—	—

8-bit timer channel 0 settings	(4)		(3)	
CKS2	0	1		
CKS1	—	0		1
CKS0	—	0	1	—

Pin Pin Functions and Selection Method

PA₂/TP₂/
TIOCA₀/
TCLKC

Bit PWM0 in TMDR, bits IOA2 to IOA0 in TIOR0, bits TPSC2 to TPSC0 in TCR2 to TCR0 of the 16-bit timer, bits CKS2 to CKS0 in TCR1 of the 8-bit timer, bit NDER2 in NDERA, and bit PA₂DDR select the pin function as follows.

16-bit timer channel 0 settings	(1) in table below	(2) in table below		
PA ₂ DDR	—	0	1	1
NDER2	—	—	0	1
Pin function	TIOCA ₀ output	PA ₂ input	PA ₂ output	TP ₂ output
		TIOCA ₀ input* ¹		
		TCLKC input* ²		

- Notes: 1. TIOCA₀ input when IOA2 = 1.
 2. TCLKC input when TPSC2 = TPSC1 = 1 and TPSC0 = 0 in any of TCR2 to TCR0, or bits CKS2 to CKS0 in TCR1 are as shown in (3) in the table below.

16-bit timer channel 0 settings	(2)	(1)		(2)	(1)
PWM0	0				1
IOA2	0			1	—
IOA1	0	0	1	—	—
IOA0	0	1	—	—	—

8-bit timer channel 1 settings	(4)		(3)		
CKS2	0	1			
CKS1	—	0			1
CKS0	—	0	1	—	

Pin Pin Functions and Selection Method

PA₁/TP₁/
TCLKB/
TEND₁ Bit MDF in TMDR, bits TPSC2 to TPSC0 in TCR2 to TCR0 of the 16-bit timer, bits CKS2 to CKS0 in TCR2 of the 8-bit timer, bit NDER1 in NDERA, and bit PA₁DDR select the pin function as follows.

PA ₁ DDR	0	1	1
NDER1	—	0	1
Pin function	PA ₁ input	PA ₁ output	TP ₁ output
	TCLKB input* ¹		
	TEND ₁ output* ²		

- Notes:
1. TCLKB input when MDF = 1 in TMDR, or TPSC2 = 1, TPSC1 = 0, and TPSC0 = 1 in any of TCR2 to TCR0, or bits CKS2 to CKS0 in TCR2 are as shown in (1) in the table below.
 2. When an external request is specified as a DMAC activation source, TEND₁ output regardless of bits PA₁DDR and NDER1.

8-bit timer channel 1 settings	(2)		(1)	
	0	1		
	—	0		1
	—	0	1	—

PA₀/TP₀/
TCLKA/
TEND₀ Bit MDF in TMDR, bits TPSC2 to TPSC0 in TCR2 to TCR0 of the 16-bit timer, bits CKS2 to CKS0 in TCR0 of the 8-bit timer, bit NDER0 in NDERA, and bit PA₀DDR select the pin function as follows.

PA ₀ DDR	0	1	
NDER0	—	0	1
Pin function	PA ₀ input	PA ₀ output	TP ₀ output
	TCLKA input* ¹		
	TEND ₀ output* ²		

- Notes:
1. TCLKA input when MDF = 1 in TMDR, or TPSC2 = 1, TPSC1 = 0 and TPSC0 = 0 in any of TCR2 to TCR0, or bits CKS2 to CKS0 in TCR0 are as shown in (1) in the table below.
 2. When an external request is specified as a DMAC activation source, TEND₀ output regardless of bits PA₀DDR and NDER0.

8-bit timer channel 0 settings	(2)		(1)	
	0	1		
	—	0		1
	—	0	1	—

8.8 Port B

8.8.1 Overview

Port B is an 8-bit input/output port that is also used for output (TP₁₅ to TP₈) from the programmable timing pattern controller (TPC), input/output (TMIO₃, TMO₂, TMIO₁, TMO₀) by the 8-bit timer, \overline{CS}_7 to \overline{CS}_4 output, input (DREQ₁, DREQ₀) to the DMA controller (DMAC), input and output (TxD₂, RxD₂, SCK₂) by serial communication interface channel 2 (SCI2), and output (\overline{UCAS} , \overline{LCAS}) by the DRAM interface. See table 8.16 for the selection of pin functions.

A reset or hardware standby transition leaves port B as an input port. For output of \overline{CS}_7 to \overline{CS}_4 in modes 1 to 4, see section 6.3.4, Chip Select Signals. Pins not assigned to any of these functions are available for generic input/output. When DRAM is connected to areas 2 to 5, the \overline{CS}_4 and \overline{CS}_5 output pins function as \overline{RAS} output pins for each area. For details see section 6.5, DRAM Interface. Figure 8.7 shows the pin configuration of port B.

Pins in port B can drive one TTL load and a 30-pF capacitive load. They can also drive darlington transistor pair.

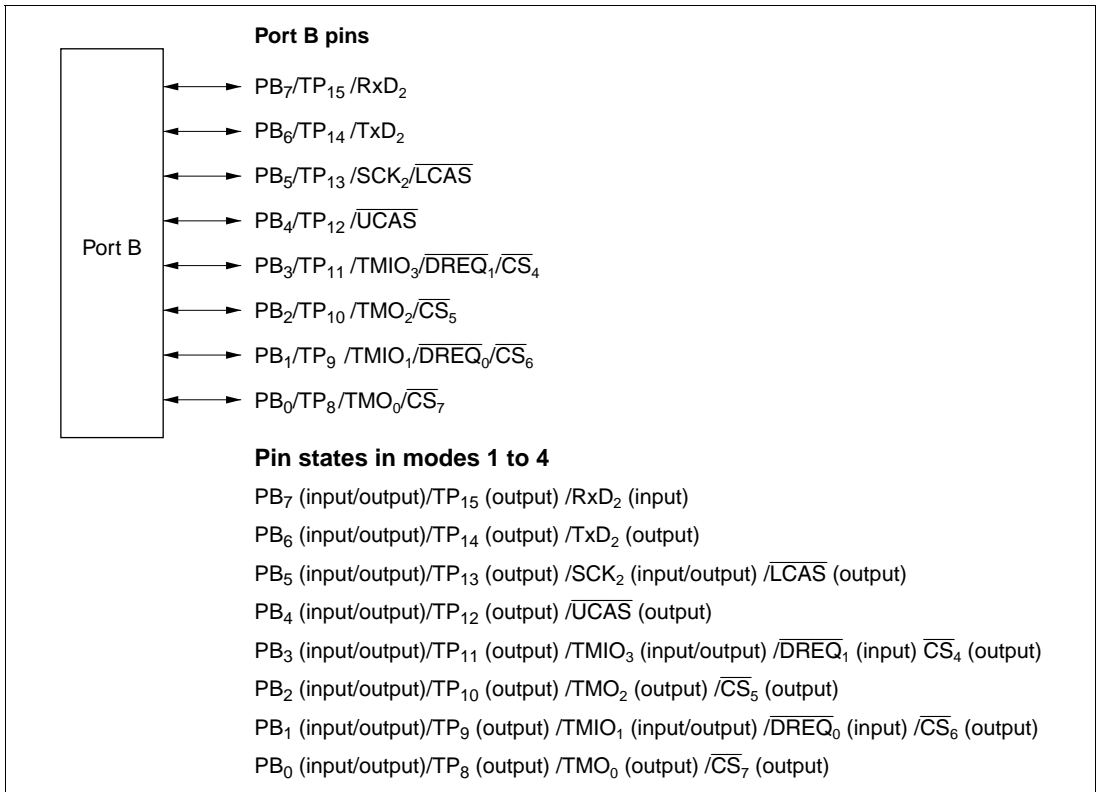

Figure 8.7 Port B Pin Configuration

8.8.2 Register Configuration

Table 8.15 summarizes the registers of port B.

Table 8.15 Port B Registers

Address*	Name	Abbreviation	R/W	Initial Value
H'EE00A	Port B data direction register	PBDDR	W	H'00
H'FFFDA	Port B data register	PBDR	R/W	H'00

Note: * Lower 20 bits of the address in advanced mode.

Port B Data Direction Register (PBDDR): PBDDR is an 8-bit write-only register that can select input or output for each pin in port B. When pins are used for TPC output, the corresponding PBDDR bits must also be set.

Bit	7	6	5	4	3	2	1	0
	PB ₇ DDR	PB ₆ DDR	PB ₅ DDR	PB ₄ DDR	PB ₃ DDR	PB ₂ DDR	PB ₁ DDR	PB ₀ DDR
Initial value	0	0	0	0	0	0	0	0
Read/Write	W	W	W	W	W	W	W	W

Port B data direction 7 to 0

These bits select input or output for port B pins

When a pin in port B becomes an output port if the corresponding PBDDR bit is set to 1, and an input port if this bit is cleared to 0.

PBDDR is a write-only register. Its value cannot be read. All bits return 1 when read.

PBDDR is initialized to H'00 by a reset and in hardware standby mode. In software standby mode it retains its previous setting. When transition is made to software standby mode while a PBDDR bit is set to 1, the corresponding pin maintains its output state.

Port B Data Register (PBDR): PBDR is an 8-bit readable/writable register that stores output data for pins port B. When port B functions as an output port, the value of this register is output. When a bit in PBDDR is set to 1, if port B is read the value of the corresponding PBDR bit is returned. When a bit in PBDDR is cleared to 0, if port B is read the corresponding pin level is read.

Bit	7	6	5	4	3	2	1	0
	PB ₇	PB ₆	PB ₅	PB ₄	PB ₃	PB ₂	PB ₁	PB ₀
Initial value	0	0	0	0	0	0	0	0
Read/Write	R/W	R/W	R/W	R/W	R/W	R/W	R/W	R/W

Port B data 7 to 0

These bits store data for port B pins

PBDR is initialized to H'00 by a reset and in hardware standby mode. In software standby mode it retains its previous setting.

Table 8.16 Port B Pin Functions
Pin Pin Functions and Selection Method

$PB_7/TP_{15}/RxD_2$ Bit RE in SCR of SCI2, bit SMIF in SCMR, bit NDER15 in NDERB, and bit PB_7DDR select the pin function as follows.

SMIF	0				1
RE	0			1	—
PB_7DDR	0	1	1	—	—
NDER15	—	0	1	—	—
Pin function	PB_7 input	PB_7 output	TP_{15} output	RxD_2 input	RxD_2 input

$PB_6/TP_{14}/TxD_2$ Bit TE in SCR of SCI2, bit SMIF in SCMR, bit NDER14 in NDERB, and bit PB_6DDR select the pin function as follows.

SMIF	0				1
TE	0			1	—
PB_6DDR	0	1	1	—	—
NDER14	—	0	1	—	—
Pin function	PB_6 input	PB_6 output	TP_{14} output	TxD_2 output	TxD_2 output*

Note: * Functions as the TxD_2 output pin, but there are two states: one in which the pin is driven, and another in which the pin is at high-impedance.

$PB_5/TP_{13}/SCK_2/LCAS$ Bit C/\bar{A} in SMR of SCI2, bits CKE0 and CKE1 in SCR, bit NDER13 in NDERB, and bit PB_5DDR select the pin function as follows.

CKE1	0				1
C/\bar{A}	0			1	—
CKE0	0		1	—	—
PB_5DDR	0	1	1	—	—
NDER13	—	0	1	—	—
Pin function	PB_5 input	PB_5 output	TP_{13} output	SCK_2 output	SCK_2 output
	\overline{LCAS} output*				

Note: * \overline{LCAS} output depending on bits DRAS2 to DRAS0 in DRCRA and bit CSEL in DRCRB, and regardless of bits C/\bar{A} , CKE0 and CKE1, NDER13, and PB_5DDR . For details, see section 6, Bus Controller.

$PB_4/TP_{12}/UCAS$ Bit NDER12 in NDERB and bit PB_4DDR select the pin function as follows.

PB_4DDR	0	1	1
NDER12	—	0	1
Pin function	PB_4 input	PB_4 output	TP_{12} output
	\overline{UCAS} output*		

Note: * \overline{UCAS} output depending on bits DRAS2 to DRAS0 in DRCRA and bit CSEL in DRCRB, and regardless of bits NDER12 and PB_4DDR . For details, see section 6, Bus Controller.

Pin Pin Functions and Selection Method

$PB_2/TP_{11}/TMIO_3/\overline{DREQ}_4/\overline{CS}_4$ The DRAM interface settings by bits DRAS2 to DRAS0 in DRCRA, bits OIS3/2 and OS1/0 in TCSR3, bits CCLR1 and CCLR0 in TCR3, bit CS4E in CSCR, bit NDER11 in NDERB, and bit PB_3 DDR select the pin function as follows.

DRAM interface settings	(1) in table below					(2) in table below
OIS3/2 and OS1/0	All 0				Not all 0	—
CS4E	0			1	—	—
PB_3 DDR	0	1	1	—	—	—
NDER11	—	0	1	—	—	—
Pin function	PB_3 input	PB_3 output	TP_{11} output	\overline{CS}_4 output	$TMIO_3$ output	\overline{CS}_4 output*3
	$TMIO_3$ input*1					
	\overline{DREQ}_1 input*2					

- Notes:
1. $TMIO_3$ input when CCLR1 = CCLR0 = 1.
 2. When an external request is specified as a DMAC activation source, \overline{DREQ}_1 input regardless of bits OIS3 and OIS2, OS1 and OS0, CCLR1 and CCLR0, CS4E, NDER11, and PB_3 DDR.
 3. \overline{CS}_4 is output as \overline{RAS}_4 .

DRAM interface settings	(1)				(2)			(1)
DRAS2	0				1			
DRAS1	0		1		0		1	
DRAS0	0	1	0	1	0	1	0	1

$PB_2/TP_{10}/TMIO_2/\overline{CS}_5$ The DRAM interface settings by bits DRAS2 to DRAS0 in DRCRA, bits OIS3/2 and OS1/0 in TCSR2, bit CS5E in CSCR, bit NDER10 in NDERB, and bit PB_2 DDR select the pin function as follows.

DRAM interface settings	(1) in table below					(2) in table below
OIS3/2 and OS1/0	All 0				Not all 0	—
CS5E	0			1	—	—
PB_2 DDR	0	1	1	—	—	—
NDER10	—	0	1	—	—	—
Pin function	PB_2 input	PB_2 output	TP_{10} output	\overline{CS}_5 output	$TMIO_2$ output	\overline{CS}_5 output*
	$TMIO_2$ input*1					
	\overline{DREQ}_1 input*2					

Note: * \overline{CS}_5 is output as \overline{RAS}_5 .

DRAM interface settings	(1)				(2)	(1)		
DRAS2	0				1			
DRAS1	0		1		0		1	
DRAS0	0	1	0	1	0	1	0	1

Pin Pin Functions and Selection Method

PB_1/TP_9 Bits OIS3/2 and OS1/0 in TCSR1, bits CCLR1 and CCLR0 in TCR1, bit CS6E in CSCR, bit NDER9 in
 $TMIO_1/\overline{CS}_6$ NDERB, and bit PB_1 DDR select the pin function as follows.
 $\overline{DREQ}_0/\overline{CS}_6$

OIS3/2 and OS1/0	All 0				Not all 0
CS6E	0			1	—
PB_1 DDR	0	1	1	—	—
NDER9	—	0	1	—	—
Pin function	PB_1 input	PB_1 output	TP_9 output	\overline{CS}_6 output	TMIO ₁ output
	TMIO ₁ input* ¹				
	\overline{DREQ}_0 input* ²				

- Notes: 1. TMIO₁ input when CCLR1 = CCLR0 = 1.
 2. \overline{DREQ}_0 input when an external request is specified as a DMAC activation source, regardless of bits OIS3/2, OS1/0, CCLR1/0, CS6E, NDER9, PB_1 DDR.

PB_0/TP_8 Bits OIS3/2 and OS1/0 in TCSR0, bit CS7E in CSCR, bit NDER8 in NDERB, and bit PB_0 DDR select the pin
 $TMIO_0/\overline{CS}_7$ function as follows.

OIS3/2 and OS1/0	All 0				Not all 0
CS7E	0			1	—
PB_0 DDR	0	1	1	—	—
NDER8	—	0	1	—	—
Pin function	PB_0 input	PB_0 output	TP_8 output	\overline{CS}_7 output	TMO ₀ output

Section 9 16-Bit Timer

9.1 Overview

The H8/3006 and H8/3007 have built-in 16-bit timer module with three 16-bit counter channels.

9.1.1 Features

16-bit timer features are listed below.

- Capability to process up to 6 pulse outputs or 6 pulse inputs
- Six general registers (GRs, two per channel) with independently-assignable output compare or input capture functions
- Selection of eight counter clock sources for each channel:
Internal clocks: ϕ , $\phi/2$, $\phi/4$, $\phi/8$
External clocks: TCLKA, TCLKB, TCLKC, TCLKD
- Five operating modes selectable in all channels:
 - Waveform output by compare match
Selection of 0 output, 1 output, or toggle output (only 0 or 1 output in channel 2)
 - Input capture function
Rising edge, falling edge, or both edges (selectable)
 - Counter clearing function
Counters can be cleared by compare match or input capture
 - Synchronization
Two or more timer counters (16TCNTs) can be preset simultaneously, or cleared simultaneously by compare match or input capture. Counter synchronization enables synchronous register input and output.
 - PWM mode
PWM output can be provided with an arbitrary duty cycle. With synchronization, up to three-phase PWM output is possible

- Phase counting mode selectable in channel 2
Two-phase encoder output can be counted automatically.
- High-speed access via internal 16-bit bus
The 16TCNTs and GRs can be accessed at high speed via a 16-bit bus.
- Any initial timer output value can be set
- Nine interrupt sources
Each channel has two compare match/input capture interrupts and an overflow interrupt. All interrupts can be requested independently.
- Output triggering of programmable timing pattern controller (TPC)
Compare match/input capture signals from channels 0 to 2 can be used as TPC output triggers.

Table 9.1 summarizes the 16-bit timer functions.

Table 9.1 16-bit timer Functions

Item		Channel 0	Channel 1	Channel 2
Clock sources		Internal clocks: ϕ , $\phi/2$, $\phi/4$, $\phi/8$ External clocks: TCLKA, TCLKB, TCLKC, TCLKD, selectable independently		
General registers (output compare/input capture registers)		GRA0, GRB0	GRA1, GRB1	GRA2, GRB2
Input/output pins		TIOCA ₀ , TIOCB ₀	TIOCA ₁ , TIOCB ₁	TIOCA ₂ , TIOCB ₂
Counter clearing function		GRA0/GRB0 compare match or input capture	GRA1/GRB1 compare match or input capture	GRA2/GRB2 compare match or input capture
Initial output value setting function		Available	Available	Available
Compare match output	0	Available	Available	Available
	1	Available	Available	Available
	Toggle	Available	Available	Not available
Input capture function		Available	Available	Available
Synchronization		Available	Available	Available
PWM mode		Available	Available	Available
Phase counting mode		Not available	Not available	Available
Interrupt sources		Three sources • Compare match/input capture A0 • Compare match/input capture B0 • Overflow	Three sources • Compare match/input capture A1 • Compare match/input capture B1 • Overflow	Three sources • Compare match/input capture A2 • Compare match/input capture B2 • Overflow

9.1.2 Block Diagrams

16-bit timer Block Diagram (Overall): Figure 9.1 is a block diagram of the 16-bit timer.

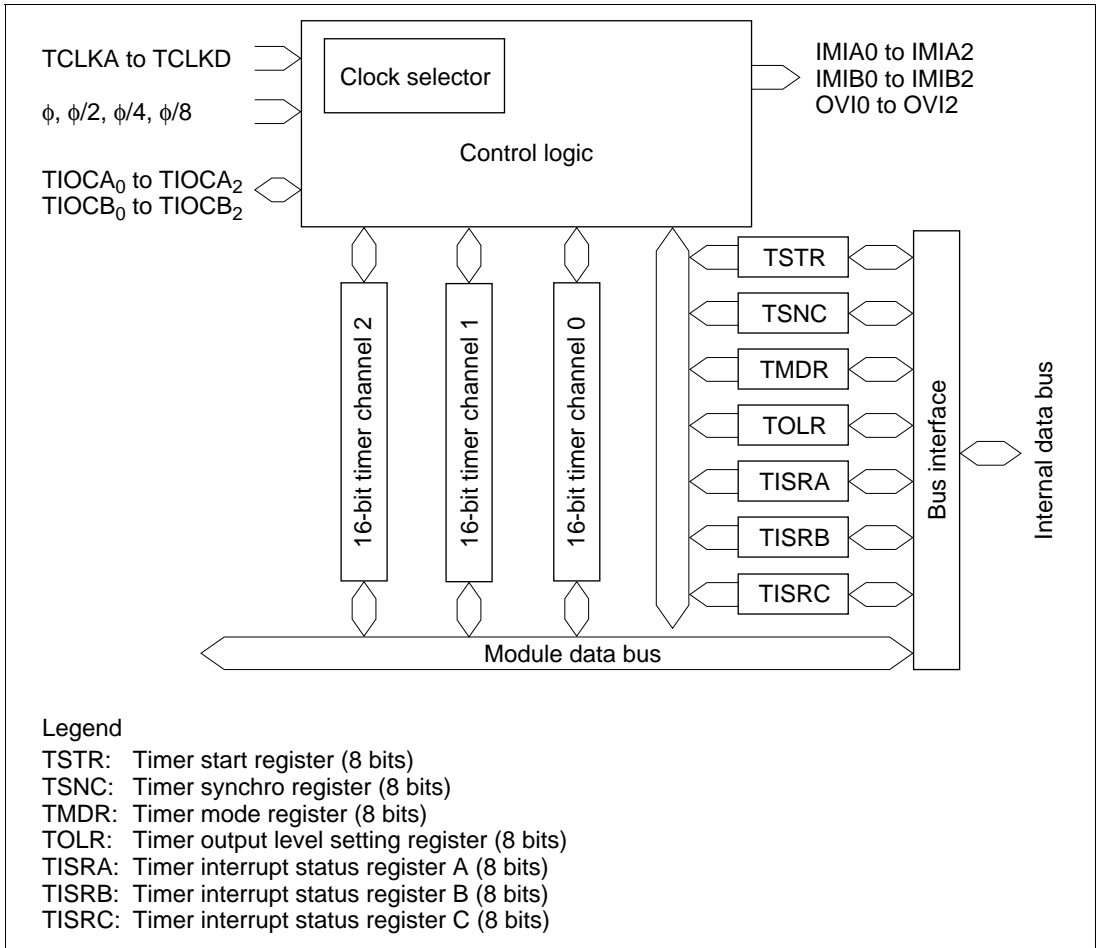

Figure 9.1 16-bit timer Block Diagram (Overall)

Block Diagram of Channels 0 and 1: 16-bit timer channels 0 and 1 are functionally identical. Both have the structure shown in figure 9.2.

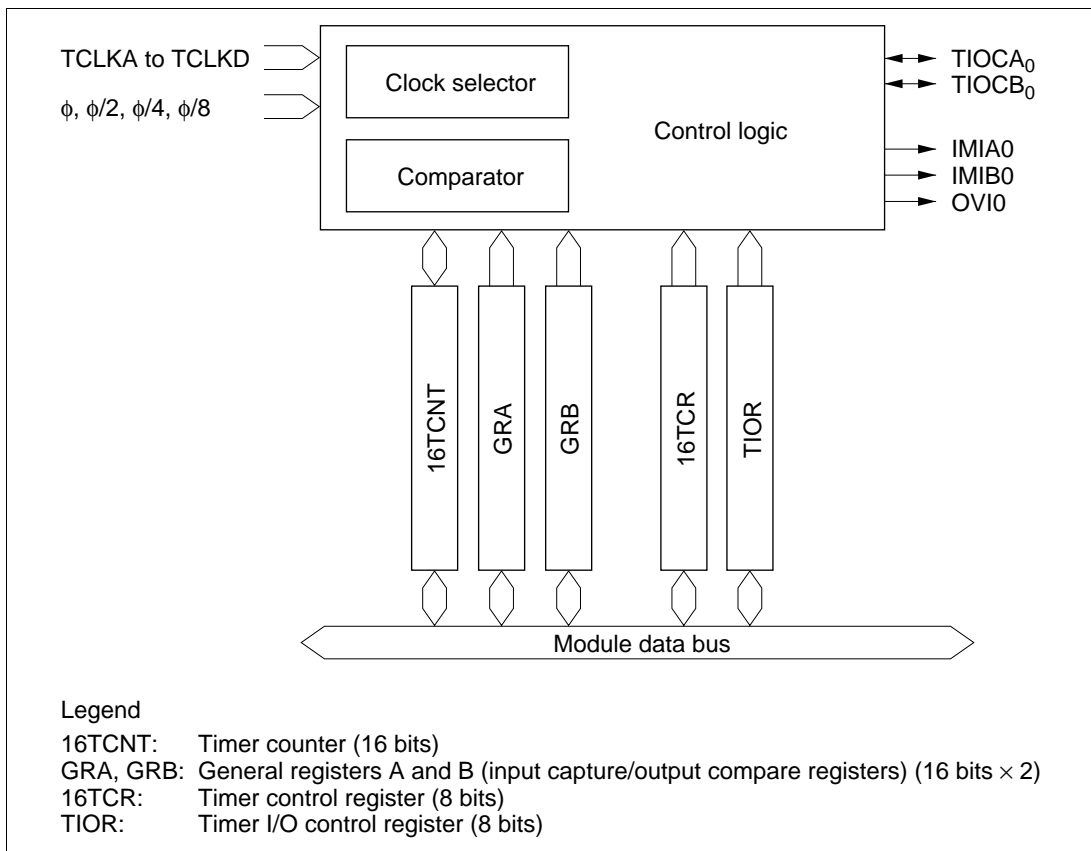

Figure 9.2 Block Diagram of Channels 0 and 1

Block Diagram of Channel 2: Figure 9.3 is a block diagram of channel 2

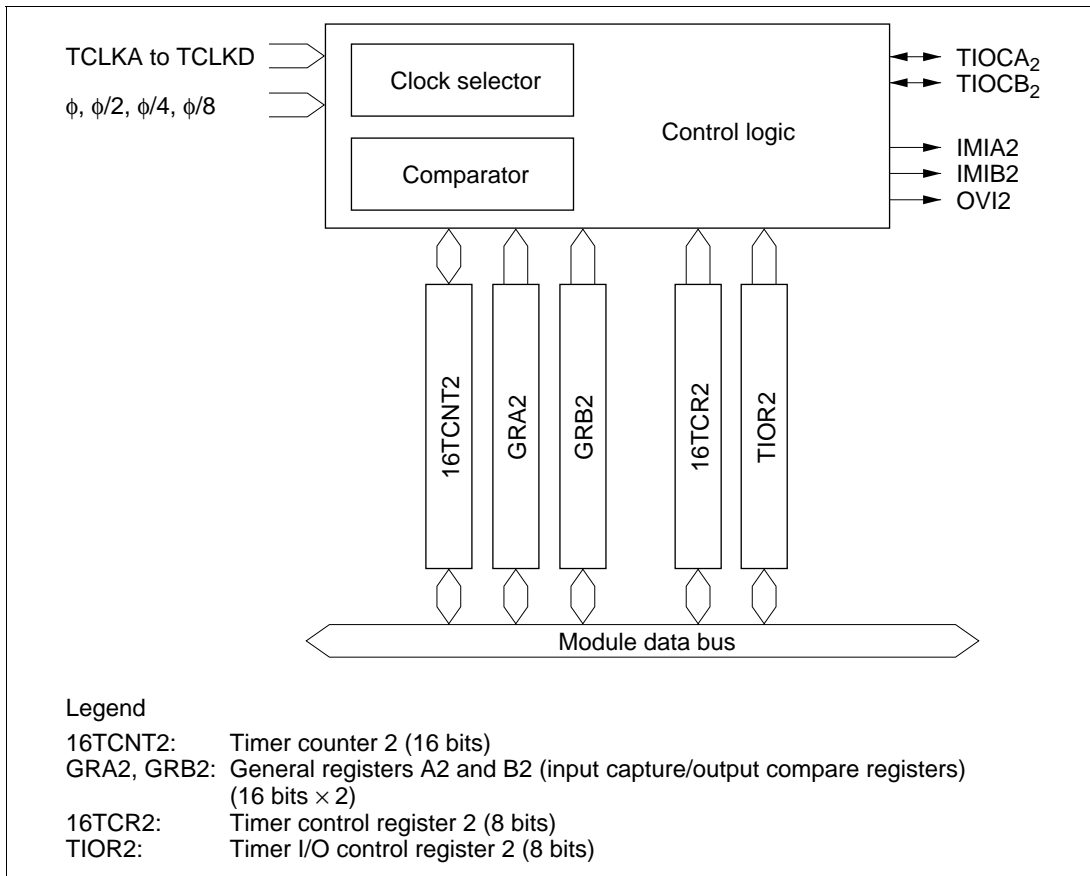

Figure 9.3 Block Diagram of Channel 2

9.1.3 Pin Configuration

Table 9.2 summarizes the 16-bit timer pins.

Table 9.2 16-bit timer Pins

Channel	Name	Abbreviation	Input/Output	Function
Common	Clock input A	TCLKA	Input	External clock A input pin (phase-A input pin in phase counting mode)
	Clock input B	TCLKB	Input	External clock B input pin (phase-B input pin in phase counting mode)
	Clock input C	TCLKC	Input	External clock C input pin
	Clock input D	TCLKD	Input	External clock D input pin
0	Input capture/output compare A0	TIOCA ₀	Input/output	GRA0 output compare or input capture pin PWM output pin in PWM mode
	Input capture/output compare B0	TIOCB ₀	Input/output	GRB0 output compare or input capture pin
1	Input capture/output compare A1	TIOCA ₁	Input/output	GRA1 output compare or input capture pin PWM output pin in PWM mode
	Input capture/output compare B1	TIOCB ₁	Input/output	GRB1 output compare or input capture pin
2	Input capture/output compare A2	TIOCA ₂	Input/output	GRA2 output compare or input capture pin PWM output pin in PWM mode
	Input capture/output compare B2	TIOCB ₂	Input/output	GRB2 output compare or input capture pin

9.1.4 Register Configuration

Table 9.3 summarizes the 16-bit timer registers.

Table 9.3 16-bit timer Registers

Channel	Address*1	Name	Abbreviation	R/W	Initial Value
Common	H'FFF60	Timer start register	TSTR	R/W	H'F8
	H'FFF61	Timer synchro register	TSNC	R/W	H'F8
	H'FFF62	Timer mode register	TMDR	R/W	H'98
	H'FFF63	Timer output level setting register	TOLR	W	H'C0
	H'FFF64	Timer interrupt status register A	TISRA	R/(W) *2	H'80
	H'FFF65	Timer interrupt status register B	TISRB	R/(W) *2	H'88
	H'FFF66	Timer interrupt status register C	TISRC	R/(W) *2	H'88
0	H'FFF68	Timer control register 0	16TCR0	R/W	H'80
	H'FFF69	Timer I/O control register 0	TIOR0	R/W	H'88
	H'FFF6A	Timer counter 0H	16TCNT0H	R/W	H'00
	H'FFF6B	Timer counter 0L	16TCNT0L	R/W	H'00
	H'FFF6C	General register A0H	GRA0H	R/W	H'FF
	H'FFF6D	General register A0L	GRA0L	R/W	H'FF
	H'FFF6E	General register B0H	GRB0H	R/W	H'FF
	H'FFF6F	General register B0L	GRB0L	R/W	H'FF
1	H'FFF70	Timer control register 1	16TCR1	R/W	H'80
	H'FFF71	Timer I/O control register 1	TIOR1	R/W	H'88
	H'FFF72	Timer counter 1H	16TCNT1H	R/W	H'00
	H'FFF73	Timer counter 1L	16TCNT1L	R/W	H'00
	H'FFF74	General register A1H	GRA1H	R/W	H'FF
	H'FFF75	General register A1L	GRA1L	R/W	H'FF
	H'FFF76	General register B1H	GRB1H	R/W	H'FF
	H'FFF77	General register B1L	GRB1L	R/W	H'FF

Channel	Address*¹	Name	Abbreviation	R/W	Initial Value
2	H'FFF78	Timer control register 2	16TCR2	R/W	H'80
	H'FFF79	Timer I/O control register 2	TIOR2	R/W	H'88
	H'FFF7A	Timer counter 2H	16TCNT2H	R/W	H'00
	H'FFF7B	Timer counter 2L	16TCNT2L	R/W	H'00
	H'FFF7C	General register A2H	GRA2H	R/W	H'FF
	H'FFF7D	General register A2L	GRA2L	R/W	H'FF
	H'FFF7E	General register B2H	GRB2H	R/W	H'FF
	H'FFF7F	General register B2L	GRB2L	R/W	H'FF

Notes: 1. The lower 20 bits of the address in advanced mode are indicated.

2. Only 0 can be written in bits 3 to 0, to clear the flags.

9.2 Register Descriptions

9.2.1 Timer Start Register (TSTR)

TSTR is an 8-bit readable/writable register that starts and stops the timer counter (16TCNT) in channels 0 to 2.

Bit	7	6	5	4	3	2	1	0
	—	—	—	—	—	STR2	STR1	STR0
Initial value	1	1	1	1	1	0	0	0
Read/Write	—	—	—	—	—	R/W	R/W	R/W

Reserved bits
Counter start 2 to 0
These bits start and stop 16TCNT2 to 16TCNT0

TSTR is initialized to 0xF8 by a reset and in standby mode.

Bits 7 to 3—Reserved: These bits cannot be modified and are always read as 1.

Bit 2—Counter Start 2 (STR2): Starts and stops timer counter 2 (16TCNT2).

Bit 2

STR2	Description
0	16TCNT2 is halted (Initial value)
1	16TCNT2 is counting

Bit 1—Counter Start 1 (STR1): Starts and stops timer counter 1 (16TCNT1).

Bit 1

STR1	Description
0	16TCNT1 is halted (Initial value)
1	16TCNT1 is counting

Bit 0—Counter Start 0 (STR0): Starts and stops timer counter 0 (16TCNT0).

Bit 0

STR0	Description
0	16TCNT0 is halted (Initial value)
1	16TCNT0 is counting

9.2.2 Timer Synchro Register (TSNC)

TSNC is an 8-bit readable/writable register that selects whether channels 0 to 2 operate independently or synchronously. Channels are synchronized by setting the corresponding bits to 1.

Bit	7	6	5	4	3	2	1	0
	—	—	—	—	—	SYNC2	SYNC1	SYNC0
Initial value	1	1	1	1	1	0	0	0
Read/Write	—	—	—	—	—	R/W	R/W	R/W

Reserved bits
Timer sync 2 to 0
These bits synchronize channels 2 to 0

TSNC is initialized to HF8 by a reset and in standby mode.

Bits 7 to 3—Reserved: These bits cannot be modified and are always read as 1.

Bit 2—Timer Sync 2 (SYNC2): Selects whether channel 2 operates independently or synchronously.

Bit 2

SYNC2 Description

0	Channel 2's timer counter (16TCNT2) operates independently 16TCNT2 is preset and cleared independently of other channels	(Initial value)
1	Channel 2 operates synchronously 16TCNT2 can be synchronously preset and cleared	

Bit 1—Timer Sync 1 (SYNC1): Selects whether channel 1 operates independently or synchronously.

Bit 1

SYNC1 Description

0	Channel 1's timer counter (16TCNT1) operates independently 16TCNT1 is preset and cleared independently of other channels	(Initial value)
1	Channel 1 operates synchronously 16TCNT1 can be synchronously preset and cleared	

Bit 0—Timer Sync 0 (SYNC0): Selects whether channel 0 operates independently or synchronously.

Bit 0

SYNC0	Description	
0	Channel 0's timer counter (16TCNT0) operates independently 16TCNT0 is preset and cleared independently of other channels	(Initial value)
1	Channel 0 operates synchronously 16TCNT0 can be synchronously preset and cleared	

9.2.3 Timer Mode Register (TMDR)

TMDR is an 8-bit readable/writable register that selects PWM mode for channels 0 to 2. It also selects phase counting mode and the overflow flag (OVF) setting conditions for channel 2.

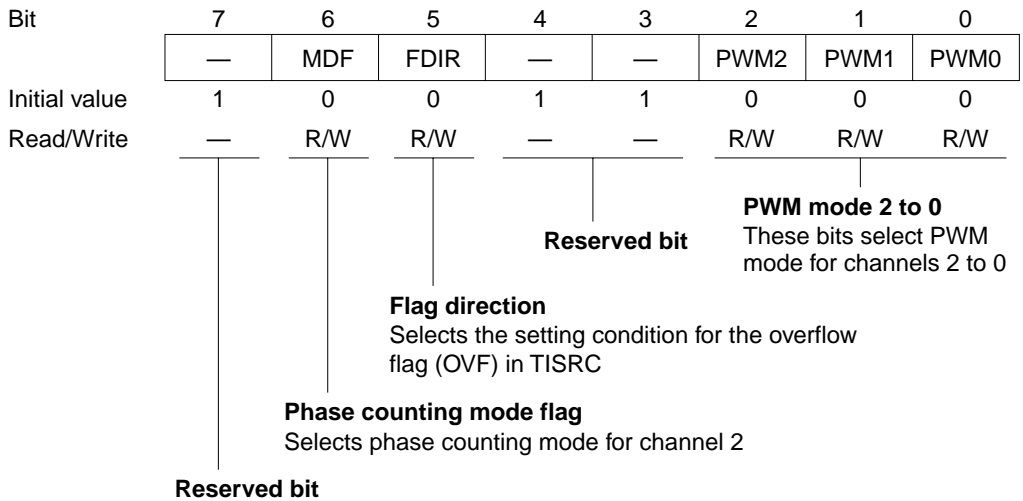

TMDR is initialized to H'98 by a reset and in standby mode.

Bit 7—Reserved: This bit cannot be modified and is always read as 1.

Bit 6—Phase Counting Mode Flag (MDF): Selects whether channel 2 operates normally or in phase counting mode.

Bit 6

MDF	Description	
0	Channel 2 operates normally	(Initial value)
1	Channel 2 operates in phase counting mode	

When MDF is set to 1 to select phase counting mode, 16TCNT2 operates as an up/down-counter and pins TCLKA and TCLKB become counter clock input pins. 16TCNT2 counts both rising and falling edges of TCLKA and TCLKB, and counts up or down as follows.

Counting Direction	Down-Counting				Up-Counting			
	↑	High	↓	Low	Low	↑	High	↓
TCLKA pin	↑	High	↓	Low	Low	↑	High	↓
TCLKB pin	Low	↑	High	↓	↑	High	↓	Low

In phase counting mode channel 2 operates as above regardless of the external clock edges selected by bits CKEG1 and CKEG0 and the clock source selected by bits TPSC2 to TPSC0. Phase counting mode takes precedence over these settings.

The counter clearing condition selected by the CCLR1 and CCLR0 bits in 16TCR2 and the compare match/input capture settings and interrupt functions of TIOR2, TISRA, TISRB, TISRC remain effective in phase counting mode.

Bit 5—Flag Direction (FDIR): Designates the setting condition for the OVF flag in TISRC. The FDIR designation is valid in all modes in channel 2.

Bit 5

FDIR	Description
0	OVF is set to 1 in TISRC when 16TCNT2 overflows or underflows (Initial value)
1	OVF is set to 1 in TISRC when 16TCNT2 overflows

Bits 4 and 3—Reserved: These bits cannot be modified and are always read as 1.

Bit 2—PWM Mode 2 (PWM2): Selects whether channel 2 operates normally or in PWM mode.

Bit 2

PWM2	Description
0	Channel 2 operates normally (Initial value)
1	Channel 2 operates in PWM mode

When bit PWM2 is set to 1 to select PWM mode, pin TIOCA₂ becomes a PWM output pin. The output goes to 1 at compare match with GRA2, and to 0 at compare match with GRB2.

Bit 1—PWM Mode 1 (PWM1): Selects whether channel 1 operates normally or in PWM mode.

Bit 1 PWM1	Description
0	Channel 1 operates normally (Initial value)
1	Channel 1 operates in PWM mode

When bit PWM1 is set to 1 to select PWM mode, pin TIOCA₁ becomes a PWM output pin. The output goes to 1 at compare match with GRA1, and to 0 at compare match with GRB1.

Bit 0—PWM Mode 0 (PWM0): Selects whether channel 0 operates normally or in PWM mode.

Bit 0 PWM0	Description
0	Channel 0 operates normally (Initial value)
1	Channel 0 operates in PWM mode

When bit PWM0 is set to 1 to select PWM mode, pin TIOCA₀ becomes a PWM output pin. The output goes to 1 at compare match with GRA0, and to 0 at compare match with GRB0.

9.2.4 Timer Interrupt Status Register A (TISRA)

TISRA is an 8-bit readable/writable register that indicates GRA compare match or input capture and enables or disables general register compare match and input capture interrupt requests.

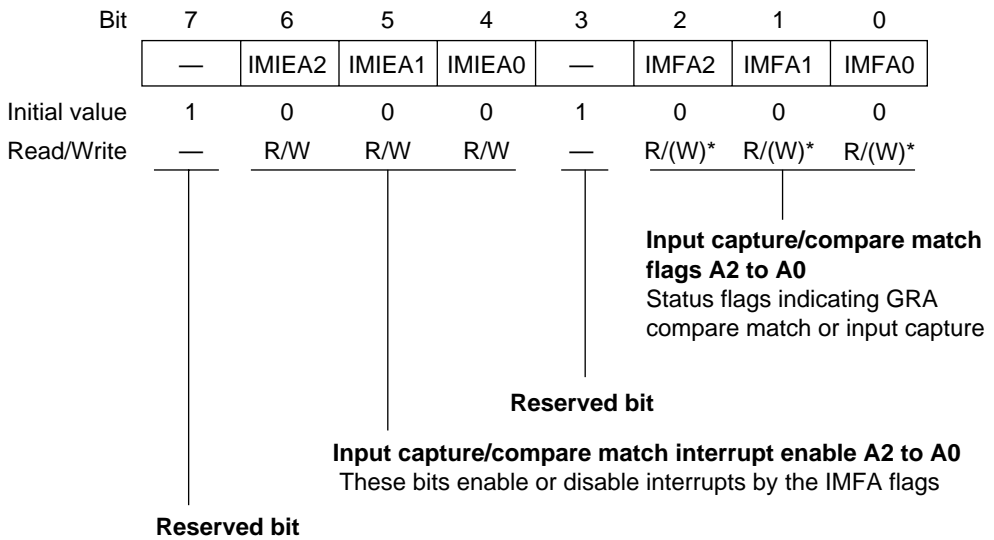

Note: * Only 0 can be written, to clear the flag.

TISRA is initialized to H'88 by a reset and in standby mode.

Bit 7—Reserved: This bit cannot be modified and is always read as 1.

Bit 6—Input Capture/Compare Match Interrupt Enable A2 (IMIEA2): Enables or disables the interrupt requested by the IMFA2 flag when IMFA2 is set to 1.

Bit 6

IMIEA2 Description

0	IMIA2 interrupt requested by IMFA2 flag is disabled	(Initial value)
1	IMIA2 interrupt requested by IMFA2 flag is enabled	

Bit 5—Input Capture/Compare Match Interrupt Enable A1 (IMIEA1): Enables or disables the interrupt requested by the IMFA1 flag when IMFA1 is set to 1.

Bit 5

IMIEA1 Description

0	IMIA1 interrupt requested by IMFA1 flag is disabled	(Initial value)
1	IMIA1 interrupt requested by IMFA1 flag is enabled	

Bit 4—Input Capture/Compare Match Interrupt Enable A0 (IMIEA0): Enables or disables the interrupt requested by the IMFA0 flag when IMFA0 is set to 1.

Bit 4

IMIEA0	Description
0	IMIA0 interrupt requested by IMFA0 flag is disabled (Initial value)
1	IMIA0 interrupt requested by IMFA0 flag is enabled

Bit 3—Reserved: This bit cannot be modified and is always read as 1.

Bit 2—Input Capture/Compare Match Flag A2 (IMFA2): This status flag indicates GRA2 compare match or input capture events.

Bit 2

IMFA2	Description
0	[Clearing conditions] (Initial value) <ul style="list-style-type: none">• Read IMFA2 when IMFA2 =1, then write 0 in IMFA2.• DMAC activated by IMIA2 interrupt.
1	[Setting conditions] <ul style="list-style-type: none">• 16TCNT2 = GRA2 when GRA2 functions as an output compare register.• 16TCNT2 value is transferred to GRA2 by an input capture signal when GRA2 functions as an input capture register.

Bit 1—Input Capture/Compare Match Flag A1 (IMFA1): This status flag indicates GRA1 compare match or input capture events.

Bit 1

IMFA1	Description
0	[Clearing conditions] (Initial value) <ul style="list-style-type: none">• Read IMFA1 when IMFA1 =1, then write 0 in IMFA1.• DMAC activated by IMIA1 interrupt.
1	[Setting conditions] <ul style="list-style-type: none">• 16TCNT1 = GRA1 when GRA1 functions as an output compare register.• 16TCNT1 value is transferred to GRA1 by an input capture signal when GRA1 functions as an input capture register.

Bit 0—Input Capture/Compare Match Flag A0 (IMFA0): This status flag indicates GRA0 compare match or input capture events.

Bit 0

IMFA0	Description
0	[Clearing conditions] (Initial value) <ul style="list-style-type: none"> Read IMFA0 when IMFA0 =1, then write 0 in IMFA0. DMAC activated by IMIA0 interrupt.
1	[Setting conditions] <ul style="list-style-type: none"> 16TCNT0 = GRA0 when GRA0 functions as an output compare register. 16TCNT0 value is transferred to GRA0 by an input capture signal when GRA0 functions as an input capture register.

9.2.5 Timer Interrupt Status Register B (TISRB)

TISRB is an 8-bit readable/writable register that indicates GRB compare match or input capture and enables or disables general register compare match and input capture interrupt requests.

Bit	7	6	5	4	3	2	1	0
	—	IMIEB2	IMIEB1	IMIEB0	—	IMFB2	IMFB1	IMFB0
Initial value	1	0	0	0	1	0	0	0
Read/Write	—	R/W	R/W	R/W	—	R/(W)*	R/(W)*	R/(W)*

Reserved bit (Bit 7)
Reserved bit (Bit 3)
Input capture/compare match interrupt enable B2 to B0
 These bits enable or disable interrupts by the IMFB flags
Input capture/compare match flags B2 to B0
 Status flags indicating GRB compare match or input capture

Note: * Only 0 can be written, to clear the flag.

TISRB is initialized to H'88 by a reset and in standby mode.

Bit 7—Reserved: This bit cannot be modified and is always read as 1.

Bit 6—Input Capture/Compare Match Interrupt Enable B2 (IMIEB2): Enables or disables the interrupt requested by the IMFB2 flag when IMFB2 is set to 1.

Bit 6

IMIEB2 Description

IMIEB2	Description	
0	IMIB2 interrupt requested by IMFB2 flag is disabled	(Initial value)
1	IMIB2 interrupt requested by IMFB2 flag is enabled	

Bit 5—Input Capture/Compare Match Interrupt Enable B1 (IMIEB1): Enables or disables the interrupt requested by the IMFB1 flag when IMFB1 is set to 1.

Bit 5

IMIEB1 Description

IMIEB1	Description	
0	IMIB1 interrupt requested by IMFB1 flag is disabled	(Initial value)
1	IMIB1 interrupt requested by IMFB1 flag is enabled	

Bit 4—Input Capture/Compare Match Interrupt Enable B0 (IMIEB0): Enables or disables the interrupt requested by the IMFB0 flag when IMFB0 is set to 1.

Bit 4

IMIEB0 Description

IMIEB0	Description	
0	IMIB0 interrupt requested by IMFB0 flag is disabled	(Initial value)
1	IMIB0 interrupt requested by IMFB0 flag is enabled	

Bit 3—Reserved: This bit cannot be modified and is always read as 1.

Bit 2—Input Capture/Compare Match Flag B2 (IMFB2): This status flag indicates GRB2 compare match or input capture events.

Bit 2

IMFB2 Description

IMFB2	Description	
0	[Clearing condition] Read IMFB2 when IMFB2 =1, then write 0 in IMFB2.	(Initial value)
1	[Setting conditions] <ul style="list-style-type: none">• 16TCNT2 = GRB2 when GRB2 functions as an output compare register.• 16TCNT2 value is transferred to GRB2 by an input capture signal when GRB2 functions as an input capture register.	

Bit 1—Input Capture/Compare Match Flag B1 (IMFB1): This status flag indicates GRB1 compare match or input capture events.

Bit 1

IMFB1	Description
0	[Clearing condition] (Initial value) Read IMFB1 when IMFB1 =1, then write 0 in IMFB1.
1	[Setting conditions] <ul style="list-style-type: none">• 16TCNT1 = GRB1 when GRB1 functions as an output compare register.• 16TCNT1 value is transferred to GRB1 by an input capture signal when GRB1 functions as an input capture register.

Bit 0—Input Capture/Compare Match Flag B0 (IMFB0): This status flag indicates GRB0 compare match or input capture events.

Bit 0

IMFB0	Description
0	[Clearing condition] (Initial value) Read IMFB0 when IMFB0 =1, then write 0 in IMFB0.
1	[Setting conditions] <ul style="list-style-type: none">• 16TCNT0 = GRB0 when GRB0 functions as an output compare register.• 16TCNT0 value is transferred to GRB0 by an input capture signal when GRB0 functions as an input capture register.

9.2.6 Timer Interrupt Status Register C (TISRC)

TISRC is an 8-bit readable/writable register that indicates 16TCNT overflow or underflow and enables or disables overflow interrupt requests.

Bit	7	6	5	4	3	2	1	0
	—	OVIE2	OVIE1	OVIE0	—	OVF2	OVF1	OVF0
Initial value	1	0	0	0	1	0	0	0
Read/Write	—	R/W	R/W	R/W	—	R/(W)*	R/(W)*	R/(W)*

Reserved bit
 These bits enable or disable interrupts by the OVF flags

Reserved bit
 Status flags indicating overflow or underflow

Note: * Only 0 can be written, to clear the flag.

TISRC is initialized to H'88 by a reset and in standby mode.

Bit 7—Reserved: This bit cannot be modified and is always read as 1.

Bit 6—Overflow Interrupt Enable 2 (OVIE2): Enables or disables the interrupt requested by the OVF2 flag when OVF2 is set to 1.

Bit 6

OVIE2 Description

0	OVI2 interrupt requested by OVF2 flag is disabled	(Initial value)
1	OVI2 interrupt requested by OVF2 flag is enabled	

Bit 5—Overflow Interrupt Enable 1 (OVIE1): Enables or disables the interrupt requested by the OVF1 flag when OVF1 is set to 1.

Bit 5

OVIE1 Description

0	OVI1 interrupt requested by OVF1 flag is disabled	(Initial value)
1	OVI1 interrupt requested by OVF1 flag is enabled	

Bit 4—Overflow Interrupt Enable 0 (OVIE0): Enables or disables the interrupt requested by the OVF0 flag when OVF0 is set to 1.

Bit 4

OVIE0	Description	
0	OVI0 interrupt requested by OVF0 flag is disabled	(Initial value)
1	OVI0 interrupt requested by OVF0 flag is enabled	

Bit 3—Reserved: This bit cannot be modified and is always read as 1.

Bit 2—Overflow Flag 2 (OVF2): This status flag indicates 16TCNT2 overflow.

Bit 2

OVF2	Description	
0	[Clearing condition] Read OVF2 when OVF2 =1, then write 0 in OVF2.	(Initial value)
1	[Setting condition] 16TCNT2 overflowed from H'FFFF to H'0000, or underflowed from H'0000 to H'FFFF.	

Note: 16TCNT underflow occurs when 16TCNT operates as an up/down-counter. Underflow occurs only when channel 2 operates in phase counting mode (MDF = 1 in TMDR).

Bit 1—Overflow Flag 1 (OVF1): This status flag indicates 16TCNT1 overflow.

Bit 1

OVF1	Description	
0	[Clearing condition] Read OVF1 when OVF1 =1, then write 0 in OVF1.	(Initial value)
1	[Setting condition] 16TCNT1 overflowed from H'FFFF to H'0000.	

Bit 0—Overflow Flag 0 (OVF0): This status flag indicates 16TCNT0 overflow.

Bit 0

OVF0	Description	
0	[Clearing condition] Read OVF0 when OVF0 =1, then write 0 in OVF0.	(Initial value)
1	[Setting condition] 16TCNT0 overflowed from H'FFFF to H'0000.	

9.2.7 Timer Counters (16TCNT)

16TCNT is a 16-bit counter. The 16-bit timer has three 16TCNTs, one for each channel.

Channel	Abbreviation	Function
0	16TCNT0	Up-counter
1	16TCNT1	
2	16TCNT2	Phase counting mode: up/down-counter Other modes: up-counter

Bit	15	14	13	12	11	10	9	8	7	6	5	4	3	2	1	0
	<input type="checkbox"/>	<input type="checkbox"/>	<input type="checkbox"/>	<input type="checkbox"/>	<input type="checkbox"/>	<input type="checkbox"/>	<input type="checkbox"/>	<input type="checkbox"/>	<input type="checkbox"/>	<input type="checkbox"/>	<input type="checkbox"/>	<input type="checkbox"/>	<input type="checkbox"/>	<input type="checkbox"/>	<input type="checkbox"/>	<input type="checkbox"/>
Initial value	0	0	0	0	0	0	0	0	0	0	0	0	0	0	0	0
Read/Write	R/W	R/W	R/W	R/W	R/W	R/W	R/W	R/W	R/W	R/W	R/W	R/W	R/W	R/W	R/W	R/W

Each 16TCNT is a 16-bit readable/writable register that counts pulse inputs from a clock source. The clock source is selected by bits TPSC2 to TPSC0 in 16TCR.

16TCNT0 and 16TCNT1 are up-counters. 16TCNT2 is an up/down-counter in phase counting mode and an up-counter in other modes.

16TCNT can be cleared to H'0000 by compare match with GRA or GRB or by input capture to GRA or GRB (counter clearing function).

When 16TCNT overflows (changes from H'FFFF to H'0000), the OVF flag is set to 1 in TISRC of the corresponding channel.

When 16TCNT underflows (changes from H'0000 to H'FFFF), the OVF flag is set to 1 in TISRC of the corresponding channel.

The 16TCNTs are linked to the CPU by an internal 16-bit bus and can be written or read by either word access or byte access.

Each 16TCNT is initialized to H'0000 by a reset and in standby mode.

9.2.8 General Registers (GRA, GRB)

The general registers are 16-bit registers. The 16-bit timer has 6 general registers, two in each channel.

Channel	Abbreviation	Function
0	GRA0, GRB0	Output compare/input capture register
1	GRA1, GRB1	
2	GRA2, GRB2	

Bit	15	14	13	12	11	10	9	8	7	6	5	4	3	2	1	0
Initial value	1	1	1	1	1	1	1	1	1	1	1	1	1	1	1	1
Read/Write	R/W	R/W	R/W	R/W	R/W	R/W	R/W	R/W	R/W	R/W	R/W	R/W	R/W	R/W	R/W	R/W

A general register is a 16-bit readable/writable register that can function as either an output compare register or an input capture register. The function is selected by settings in TIOR.

When a general register is used as an output compare register, its value is constantly compared with the 16TCNT value. When the two values match (compare match), the IMFA or IMFB flag is set to 1 in TISRA/TISRB. Compare match output can be selected in TIOR.

When a general register is used as an input capture register, rising edges, falling edges, or both edges of an external input capture signal are detected and the current 16TCNT value is stored in the general register. The corresponding IMFA or IMFB flag in TISRA/TISRB is set to 1 at the same time. The valid edge or edges of the input capture signal are selected in TIOR.

TIOR settings are ignored in PWM mode.

General registers are linked to the CPU by an internal 16-bit bus and can be written or read by either word access or byte access.

General registers are initialized to the output compare function (with no output signal) by a reset and in standby mode. The initial value is H'FFFF.

9.2.9 Timer Control Registers (16TCR)

16TCR is an 8-bit register. The 16-bit timer has three 16TCRs, one in each channel.

Channel	Abbreviation	Function
0	16TCR0	CR controls the timer counter. The 16TCRs in all channels are functionally identical. When phase counting mode is selected in channel 2, the settings of bits CKEG1 and CKEG0 and TPSC2 to TPSC0 in 16TCR2 are ignored.
1	16TCR1	
2	16TCR2	

Bit	7	6	5	4	3	2	1	0
	—	CCLR1	CCLR0	CKEG1	CKEG0	TPSC2	TPSC1	TPSC0
Initial value	1	0	0	0	0	0	0	0
Read/Write	—	R/W	R/W	R/W	R/W	R/W	R/W	R/W

Reserved bit
 Bit 7 is reserved and always reads as 1.

Counter clear 1/0
 Bits 6 and 5 select the counter clear source.

Clock edge 1/0
 Bits 4 and 3 select external clock edges.

Timer prescaler 2 to 0
 Bits 2, 1, and 0 select the counter clock.

Each 16TCR is an 8-bit readable/writable register that selects the timer counter clock source, selects the edge or edges of external clock sources, and selects how the counter is cleared.

16TCR is initialized to H'80 by a reset and in standby mode.

Bit 7—Reserved: This bit cannot be modified and is always read as 1.

Bits 6 and 5—Counter Clear 1/0 (CCLR1, CCLR0): These bits select how 16TCNT is cleared.

Bit 6 CCLR1	Bit 5 CCLR0	Description
0	0	16TCNT is not cleared (Initial value)
	1	16TCNT is cleared by GRA compare match or input capture* ¹
1	0	16TCNT is cleared by GRB compare match or input capture* ¹
	1	Synchronous clear: 16TCNT is cleared in synchronization with other synchronized timers* ²

Notes: 1. 16TCNT is cleared by compare match when the general register functions as an output compare register, and by input capture when the general register functions as an input capture register.

2. Selected in TSNC.

Bits 4 and 3—Clock Edge 1/0 (CKEG1, CKEG0): These bits select external clock input edges when an external clock source is used.

Bit 4 CKEG1	Bit 3 CKEG0	Description
0	0	Count rising edges (Initial value)
	1	Count falling edges
1	—	Count both edges

When channel 2 is set to phase counting mode, bits CKEG1 and CKEG0 in 16TCR2 are ignored. Phase counting takes precedence.

Bits 2 to 0—Timer Prescaler 2 to 0 (TPSC2 to TPSC0): These bits select the counter clock source.

Bit 2 TPSC2	Bit 1 TPSC1	Bit 0 TPSC0	Function
0	0	0	Internal clock: ϕ (Initial value)
		1	Internal clock: $\phi/2$
	1	0	Internal clock: $\phi/4$
		1	Internal clock: $\phi/8$
1	0	0	External clock A: TCLKA input
		1	External clock B: TCLKB input
	1	0	External clock C: TCLKC input
		1	External clock D: TCLKD input

When bit TPSC2 is cleared to 0 an internal clock source is selected, and the timer counts only falling edges. When bit TPSC2 is set to 1 an external clock source is selected, and the timer counts the edge or edges selected by bits CKEG1 and CKEG0.

When channel 2 is set to phase counting mode ($MDF = 1$ in TMDR), the settings of bits TPSC2 to TPSC0 in 16TCR2 are ignored. Phase counting takes precedence.

9.2.10 Timer I/O Control Register (TIOR)

TIOR is an 8-bit register. The 16-bit timer has three TIORs, one in each channel.

Channel	Abbreviation	Function
0	TIOR0	TIOR controls the general registers. Some functions differ in PWM mode.
1	TIOR1	
2	TIOR2	

Bit	7	6	5	4	3	2	1	0
	—	IOB2	IOB1	IOB0	—	IOA2	IOA1	IOA0
Initial value	1	0	0	0	1	0	0	0
Read/Write	—	R/W	R/W	R/W	—	R/W	R/W	R/W

Reserved bit
 I/O control B2 to B0
 These bits select GRB functions

Reserved bit
 I/O control A2 to A0
 These bits select GRA functions

Each TIOR is an 8-bit readable/writable register that selects the output compare or input capture function for GRA and GRB, and specifies the functions of the TIORA and TIORC pins. If the output compare function is selected, TIOR also selects the type of output. If input capture is selected, TIOR also selects the edge or edges of the input capture signal.

TIOR is initialized to H'88 by a reset and in standby mode.

Bit 7—Reserved: This bit cannot be modified and is always read as 1.

Bits 6 to 4—I/O Control B2 to B0 (IOB2 to IOB0): These bits select the GRB function.

Bit 6 IOB2	Bit 5 IOB1	Bit 4 IOB0	Function
0	0	0	GRB is an output compare register
		1	
	1	0	0 output at GRB compare match* ¹
		1	1 output at GRB compare match* ¹
1	0	0	GRB is an input compare register
		1	
	1	0	GRB captures falling edge of input
		1	GRB captures both edges of input

- Notes: 1. After a reset, the output conforms to the TOLR setting until the first compare match.
 2. Channel 2 output cannot be toggled by compare match. This setting selects 1 output instead.

Bit 3—Reserved: This bit cannot be modified and is always read as 1.

Bits 2 to 0—I/O Control A2 to A0 (IOA2 to IOA0): These bits select the GRA function.

Bit 2 IOA2	Bit 1 IOA1	Bit 0 IOA0	Function	
0	0	0	GRA is an output compare register	No output at compare match (Initial value)
		1		0 output at GRA compare match* ¹
	1	0		1 output at GRA compare match* ¹
		1		Output toggles at GRA compare match (1 output in channel 2)* ¹ , * ²
1	0	0	GRA is an input compare register	GRA captures rising edge of input
		1		GRA captures falling edge of input
	1	0		GRA captures both edges of input
		1		

- Notes: 1. After a reset, the output conforms to the TOLR setting until the first compare match.
 2. Channel 2 output cannot be toggled by compare match. This setting selects 1 output instead.

9.2.11 Timer Output Level Setting Register C (TOLR)

TOLR is an 8-bit write-only register that selects the timer output level for channels 0 to 2.

Bit	7	6	5	4	3	2	1	0
	—	—	TOB2	TOA2	TOB1	TOA1	TOB0	TOA0
Initial value	1	1	0	0	0	0	0	0
Read/Write	—	—	W	W	W	W	W	W

Output level setting A2 to A0, B2 to B0
 These bits set the levels of the timer outputs (TIOCA₂ to TIOCA₀, and TIOCB₂ to TIOCB₀)

A TOLR setting can only be made when the corresponding bit in TSTR is 0.

TOLR is a write-only register. If it is read, all bits will return a value of 1.

TOLR is initialized to H'00 by a reset and in standby mode.

Bits 7 and 6—Reserved: These bits cannot be modified.

Bit 5—Output Level Setting B2 (TOB2): Sets the value of timer output TIOCB₂.

Bit 5

TOB2	Description
0	TIOCB ₂ is 0 (Initial value)
1	TIOCB ₂ is 1

Bit 4—Output Level Setting A2 (TOA2): Sets the value of timer output TIOCA₂.

Bit 4

TOA2	Description
0	TIOCA ₂ is 0 (Initial value)
1	TIOCA ₂ is 1

Bit 3—Output Level Setting B1 (TOB1): Sets the value of timer output TIOCB₁.

Bit 3

TOB1	Description
0	TIOCB ₁ is 0 (Initial value)
1	TIOCB ₁ is 1

Bit 2—Output Level Setting A1 (TOA1): Sets the value of timer output TIOCA₁.

Bit 2

TOA1	Description
0	TIOCA ₁ is 0 (Initial value)
1	TIOCA ₁ is 1

Bit 1—Output Level Setting B0 (TOB0): Sets the value of timer output TIOCB₀.

Bit 0

TOB0	Description
0	TIOCB ₀ is 0 (Initial value)
1	TIOCB ₀ is 1

Bit 0—Output Level Setting A0 (TOA0): Sets the value of timer output TIOCA₀.

Bit 0

TOA0	Description	
0	TIOCA ₀ is 0	(Initial value)
1	TIOCA ₀ is 1	

9.3 CPU Interface

9.3.1 16-Bit Accessible Registers

The timer counters (16TCNTs), general registers A and B (GRAs and GRBs) are 16-bit registers, and are linked to the CPU by an internal 16-bit data bus. These registers can be written or read a word at a time, or a byte at a time.

Figures 9.4 and 9.5 show examples of word read/write access to a timer counter (16TCNT). Figures 9.6, 9.7, 9.8, and 9.9 show examples of byte read/write access to 16TCNTH and 16TCNTL.

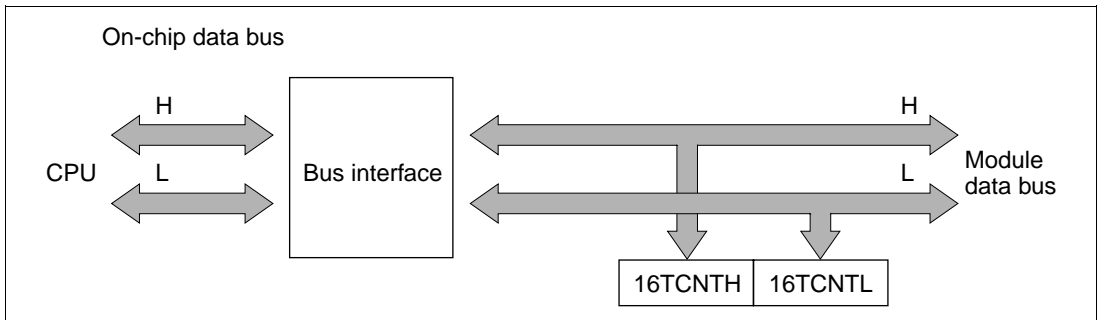

Figure 9.4 Access to Timer Counter (CPU Writes to 16TCNT, Word)

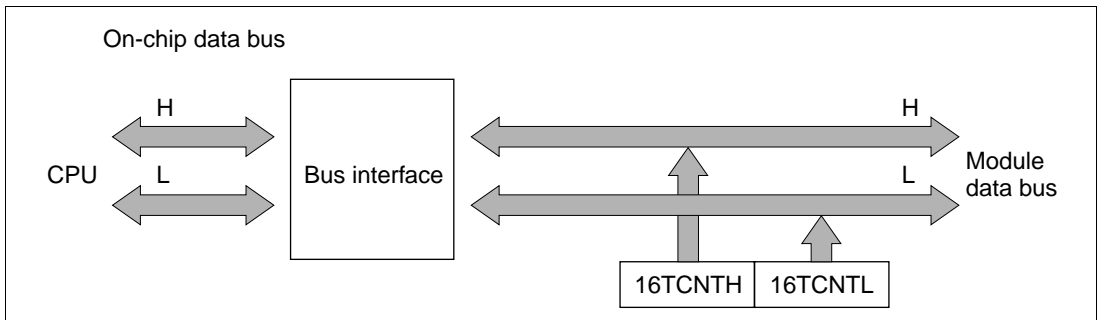

Figure 9.5 Access to Timer Counter (CPU Reads 16TCNT, Word)

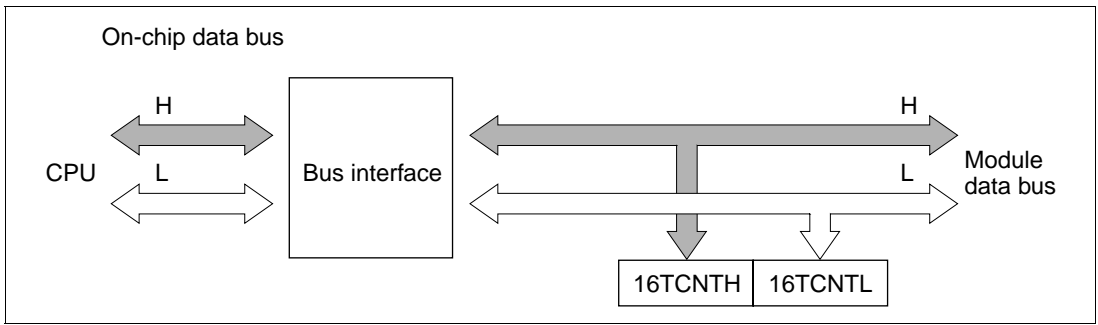

Figure 9.6 Access to Timer Counter (CPU Writes to 16TCNTH, Upper Byte)

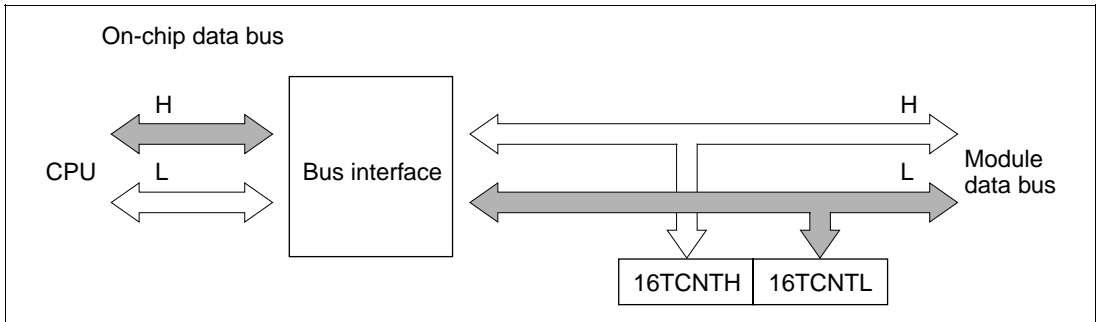

Figure 9.7 Access to Timer Counter (CPU Writes to 16TCNTL, Lower Byte)

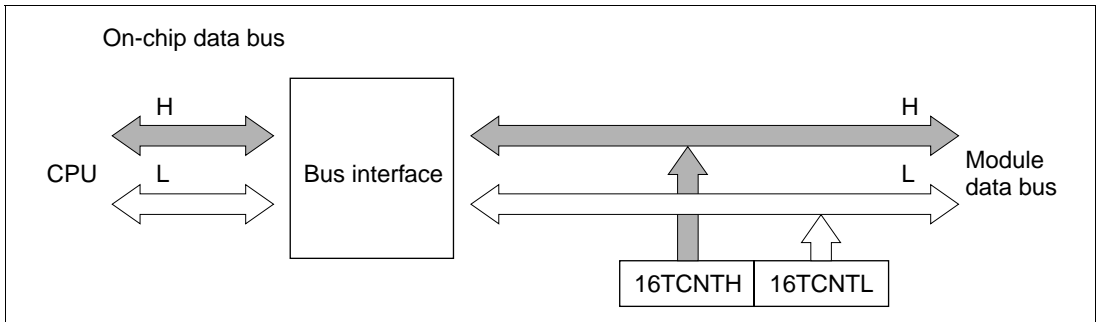

Figure 9.8 Access to Timer Counter (CPU Reads 16TCNTH, Upper Byte)

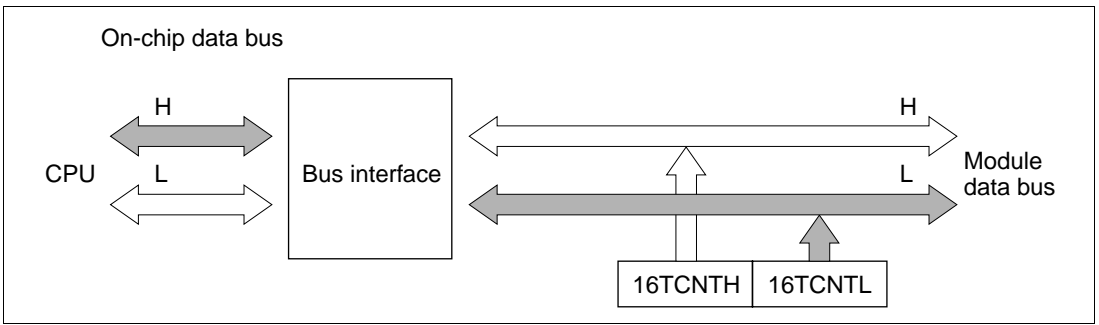

Figure 9.9 Access to Timer Counter (CPU Reads 16TCNTL, Lower Byte)

9.3.2 8-Bit Accessible Registers

The registers other than the timer counters and general registers are 8-bit registers. These registers are linked to the CPU by an internal 8-bit data bus.

Figures 9.10 and 9.11 show examples of byte read and write access to a 16TCR.

If a word-size data transfer instruction is executed, two byte transfers are performed.

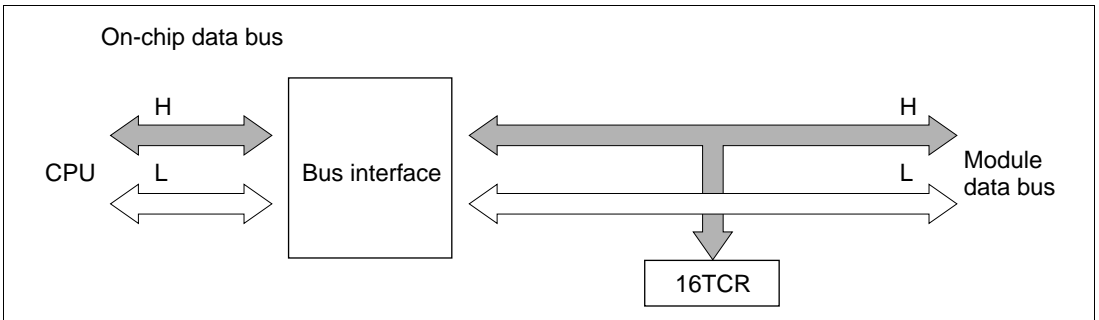

Figure 9.10 16TCR Access (CPU Writes to 16TCR)

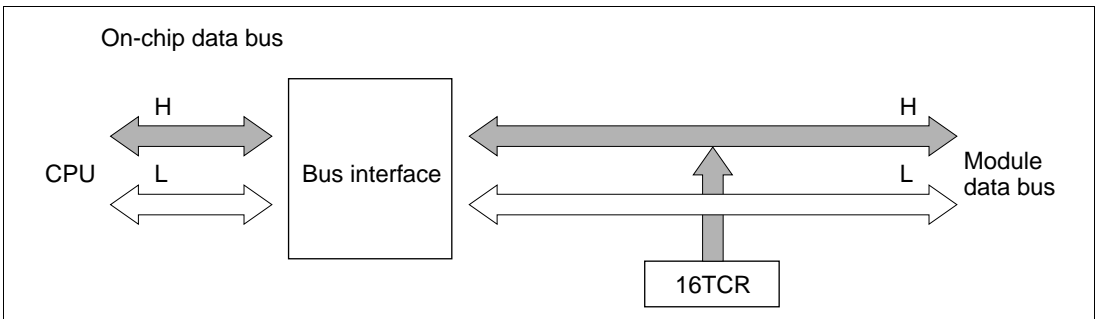

Figure 9.11 16TCR Access (CPU Reads 16TCR)

9.4 Operation

9.4.1 Overview

A summary of operations in the various modes is given below.

Normal Operation: Each channel has a timer counter and general registers. The timer counter counts up, and can operate as a free-running counter, periodic counter, or external event counter. General registers A and B can be used for input capture or output compare.

Synchronous Operation: The timer counters in designated channels are preset synchronously. Data written to the timer counter in any one of these channels is simultaneously written to the timer counters in the other channels as well. The timer counters can also be cleared synchronously if so designated by the CCLR1 and CCLR0 bits in the 16TCRs.

PWM Mode: A PWM waveform is output from the TIOCA pin. The output goes to 1 at compare match A and to 0 at compare match B. The duty cycle can be varied from 0% to 100% depending on the settings of GRA and GRB. When a channel is set to PWM mode, its GRA and GRB automatically become output compare registers.

Phase Counting Mode: The phase relationship between two clock signals input at TCLKA and TCLKB is detected and 16TCNT2 counts up or down accordingly. When phase counting mode is selected TCLKA and TCLKB become clock input pins and 16TCNT2 operates as an up/down-counter.

9.4.2 Basic Functions

Counter Operation: When one of bits STR0 to STR2 is set to 1 in the timer start register (TSTR), the timer counter (16TCNT) in the corresponding channel starts counting. The counting can be free-running or periodic.

- Sample setup procedure for counter
Figure 9.12 shows a sample procedure for setting up a counter.

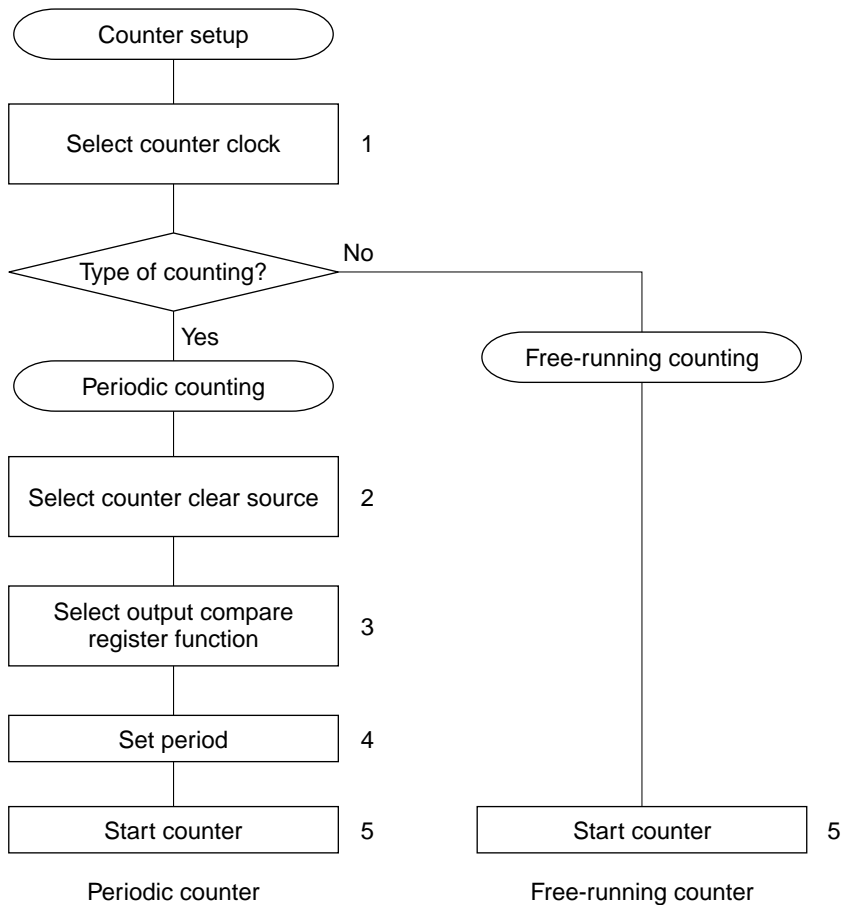

Figure 9.12 Counter Setup Procedure (Example)

1. Set bits TPSC2 to TPSC0 in 16TCR to select the counter clock source. If an external clock source is selected, set bits CKEG1 and CKEG0 in 16TCR to select the desired edge(s) of the external clock signal.
2. For periodic counting, set CCLR1 and CCLR0 in 16TCR to have 16TCNT cleared at GRA compare match or GRB compare match.
3. Set TIOR to select the output compare function of GRA or GRB, whichever was selected in step 2.
4. Write the count period in GRA or GRB, whichever was selected in step 2.
5. Set the STR bit to 1 in TSTR to start the timer counter.

- Free-running and periodic counter operation

A reset leaves the counters (16TCNTs) in 16-bit timer channels 0 to 2 all set as free-running counters. A free-running counter starts counting up when the corresponding bit in TSTR is set to 1. When the count overflows from H'FFFF to H'0000, the OVF flag is set to 1 in TISRC. After the overflow, the counter continues counting up from H'0000. Figure 9.13 illustrates free-running counting.

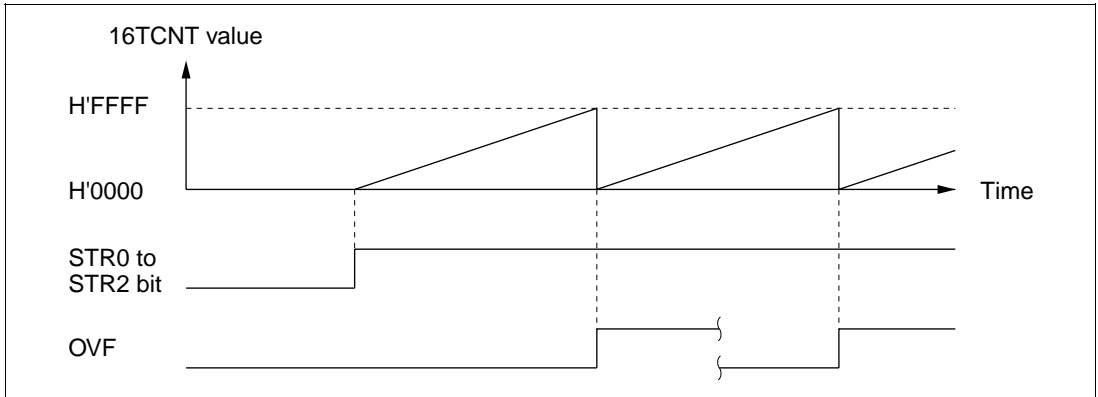

Figure 9.13 Free-Running Counter Operation

When a channel is set to have its counter cleared by compare match, in that channel 16TCNT operates as a periodic counter. Select the output compare function of GRA or GRB, set bit CCLR1 or CCLR0 in 16TCR to have the counter cleared by compare match, and set the count period in GRA or GRB. After these settings, the counter starts counting up as a periodic counter when the corresponding bit is set to 1 in TSTR. When the count matches GRA or GRB, the IMFA or IMFB flag is set to 1 in TISRA/TISRB and the counter is cleared to H'0000. If the corresponding IMIEA or IMIEB bit is set to 1 in TISRA/TISRB, a CPU interrupt is requested at this time. After the compare match, 16TCNT continues counting up from H'0000. Figure 9.14 illustrates periodic counting.

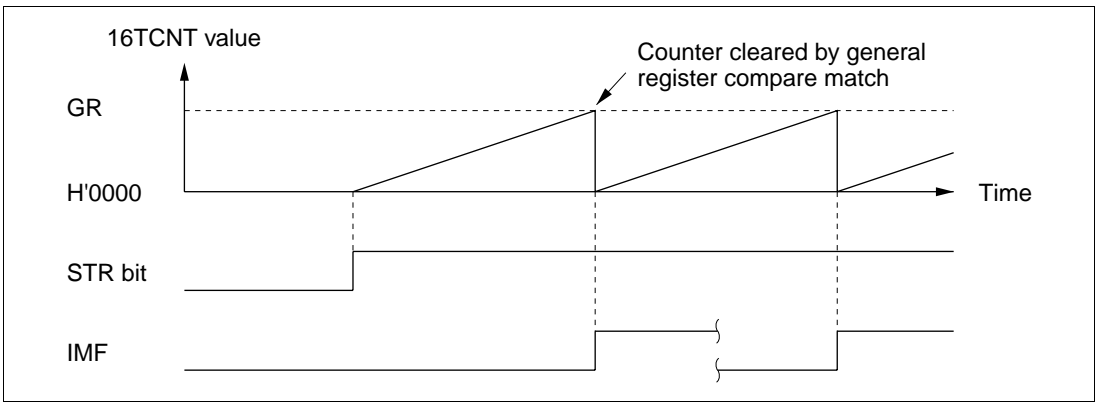

Figure 9.14 Periodic Counter Operation

- 16TCNT count timing

- Internal clock source

Bits TPSC2 to TPSC0 in 16TCR select the system clock (ϕ) or one of three internal clock sources obtained by prescaling the system clock ($\phi/2$, $\phi/4$, $\phi/8$).

Figure 9.15 shows the timing.

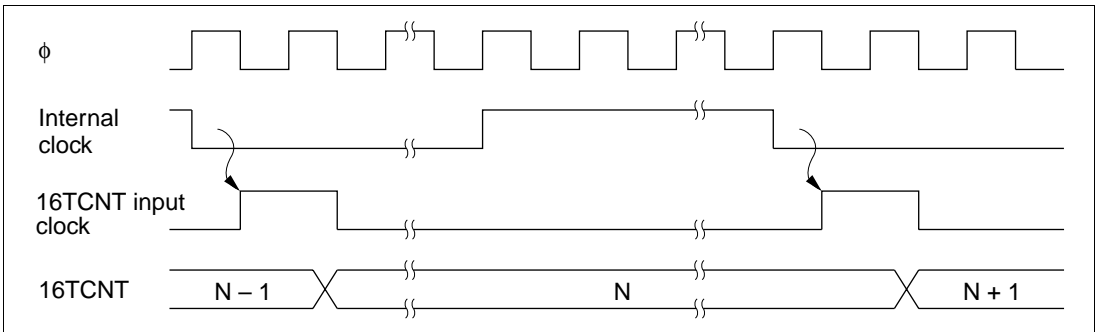

Figure 9.15 Count Timing for Internal Clock Sources

— External clock source

Bits TPSC2 to TPSC0 in 16TCR select an external clock input pin (TCLKA to TCLKD), and its valid edge or edges are selected by bits CKEG1 and CKEG0. The rising edge, falling edge, or both edges can be selected.

The pulse width of the external clock signal must be at least 1.5 system clocks when a single edge is selected, and at least 2.5 system clocks when both edges are selected. Shorter pulses will not be counted correctly.

Figure 9.16 shows the timing when both edges are detected.

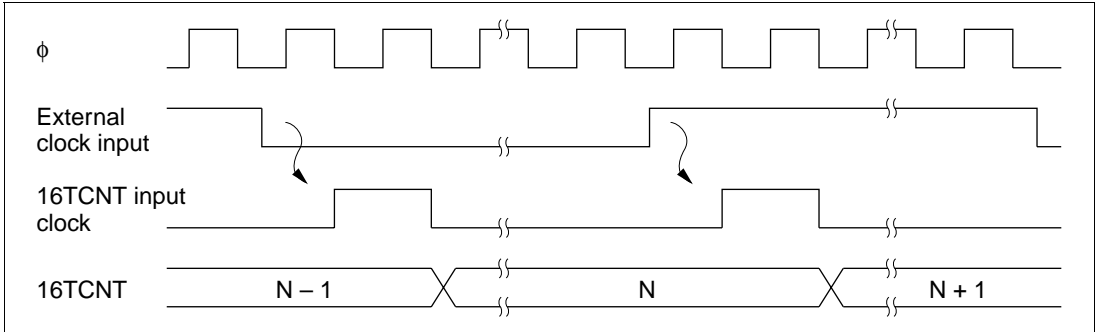

Figure 9.16 Count Timing for External Clock Sources (when Both Edges are Detected)

Waveform Output by Compare Match: In 16-bit timer channels 0, 1 compare match A or B can cause the output at the TIOCA or TIOCB pin to go to 0, go to 1, or toggle. In channel 2 the output can only go to 0 or go to 1.

- Sample setup procedure for waveform output by compare match

Figure 9.17 shows the timing for detection of both rising and falling edges.

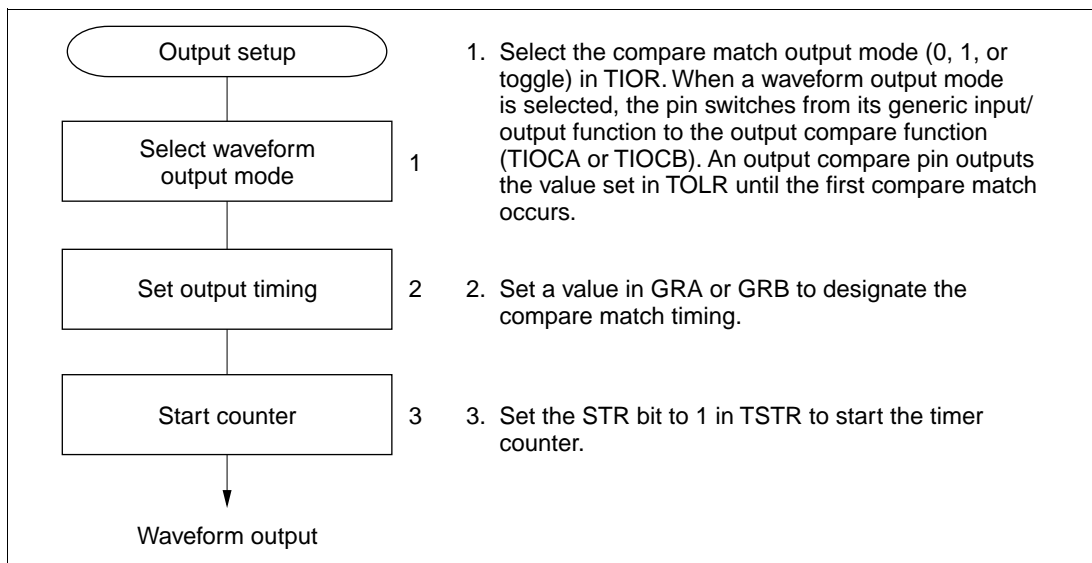

Figure 9.17 Setup Procedure for Waveform Output by Compare Match (Example)

- Examples of waveform output

Figure 9.18 shows examples of 0 and 1 output. 16TCNT operates as a free-running counter, 0 output is selected for compare match A, and 1 output is selected for compare match B. When the pin is already at the selected output level, the pin level does not change.

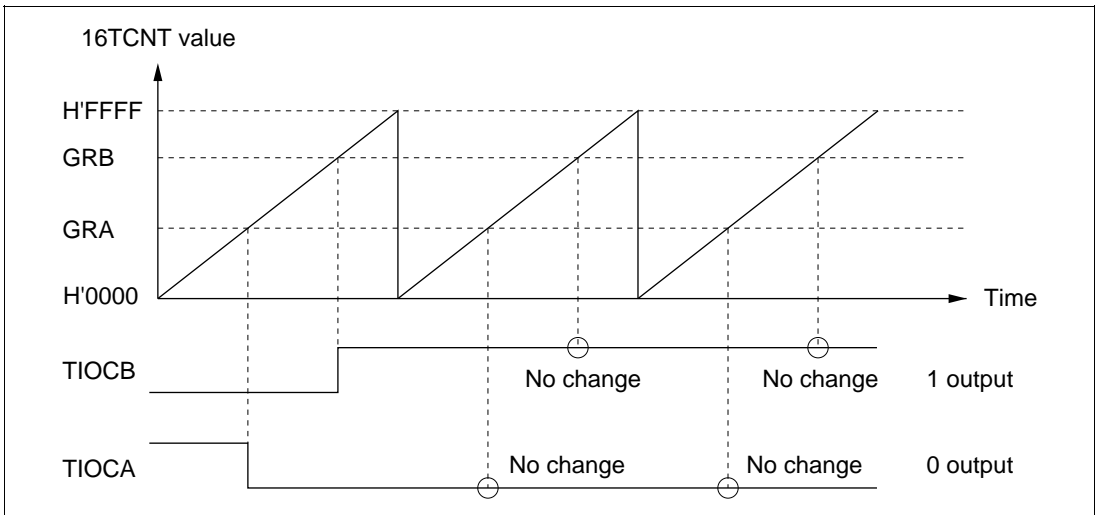

Figure 9.18 0 and 1 Output (TOA = 1, TOB = 0)

Figure 9.19 shows examples of toggle output. 16TCNT operates as a periodic counter, cleared by compare match B. Toggle output is selected for both compare match A and B.

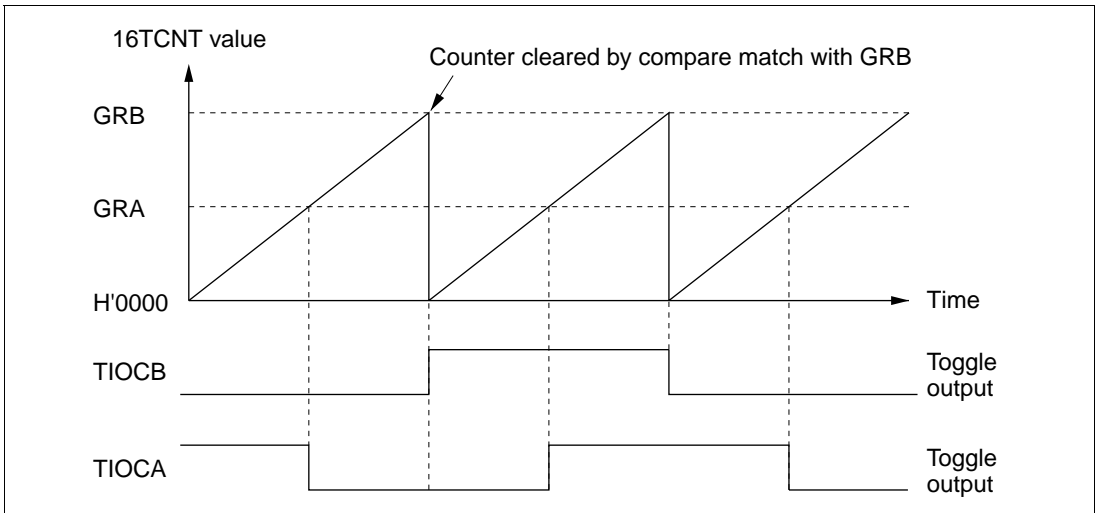

Figure 9.19 Toggle Output (TOA = 1, TOB = 0)

- Output compare output timing

The compare match signal is generated in the last state in which 16TCNT and the general register match (when 16TCNT changes from the matching value to the next value). When the compare match signal is generated, the output value selected in TIOR is output at the output compare pin (TIOCA or TIOCB). When 16TCNT matches a general register, the compare match signal is not generated until the next counter clock pulse.

Figure 9.20 shows the output compare timing.

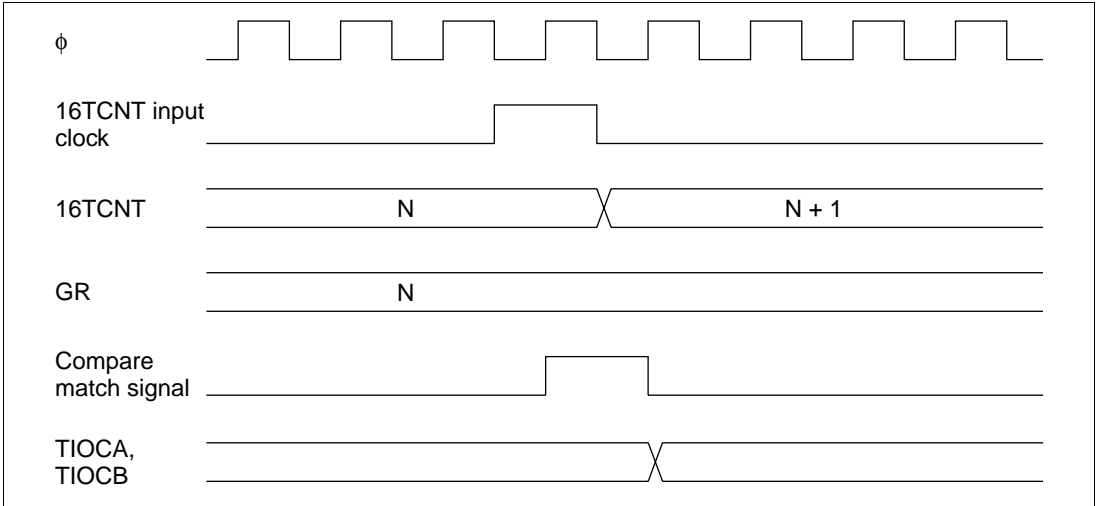

Figure 9.20 Output Compare Output Timing

Input Capture Function: The 16TCNT value can be captured into a general register when a transition occurs at an input capture/output compare pin (TIOCA or TIOCB). Capture can take place on the rising edge, falling edge, or both edges. The input capture function can be used to measure pulse width or period.

- Sample setup procedure for input capture

Figure 9.21 shows a sample procedure for setting up input capture.

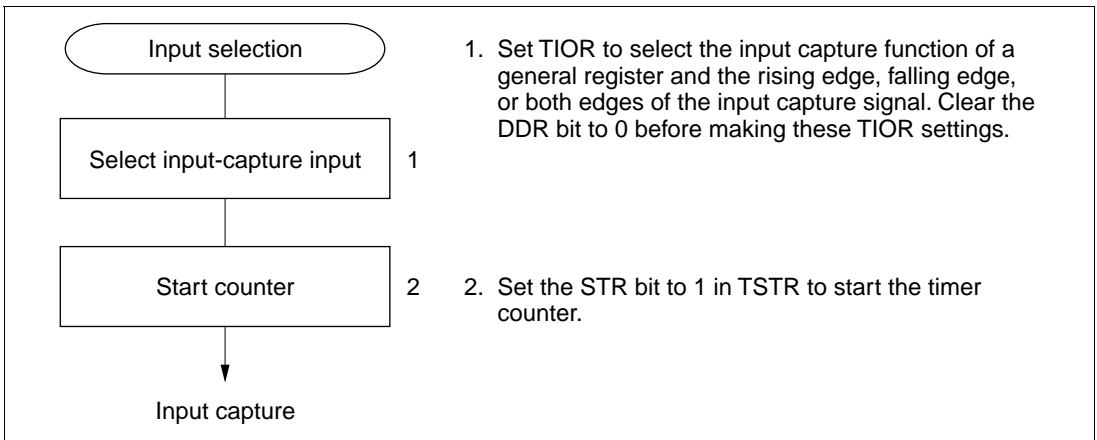

Figure 9.21 Setup Procedure for Input Capture (Example)

- Examples of input capture

Figure 9.22 illustrates input capture when the falling edge of TIOCB and both edges of TIOCA are selected as capture edges. 16TCNT is cleared by input capture into GRB.

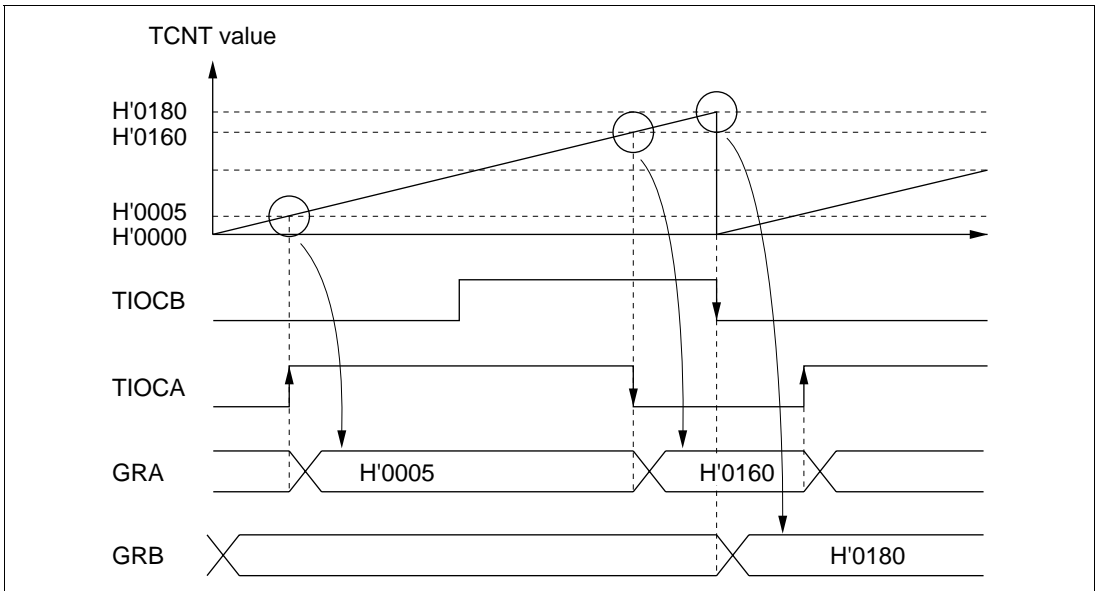

Figure 9.22 Input Capture (Example)

- Input capture signal timing

Input capture on the rising edge, falling edge, or both edges can be selected by settings in TIOR. Figure 9.23 shows the timing when the rising edge is selected. The pulse width of the input capture signal must be at least 1.5 system clocks for single-edge capture, and 2.5 system clocks for capture of both edges.

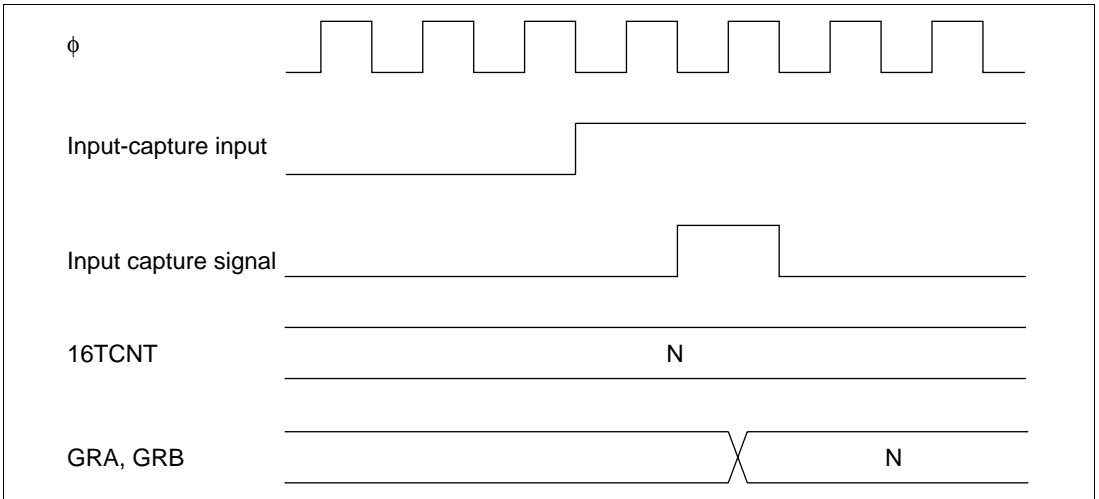

Figure 9.23 Input Capture Signal Timing

9.4.3 Synchronization

The synchronization function enables two or more timer counters to be synchronized by writing the same data to them simultaneously (synchronous preset). With appropriate 16TCR settings, two or more timer counters can also be cleared simultaneously (synchronous clear). Synchronization enables additional general registers to be associated with a single time base. Synchronization can be selected for all channels (0 to 2).

Sample Setup Procedure for Synchronization: Figure 9.24 shows a sample procedure for setting up synchronization.

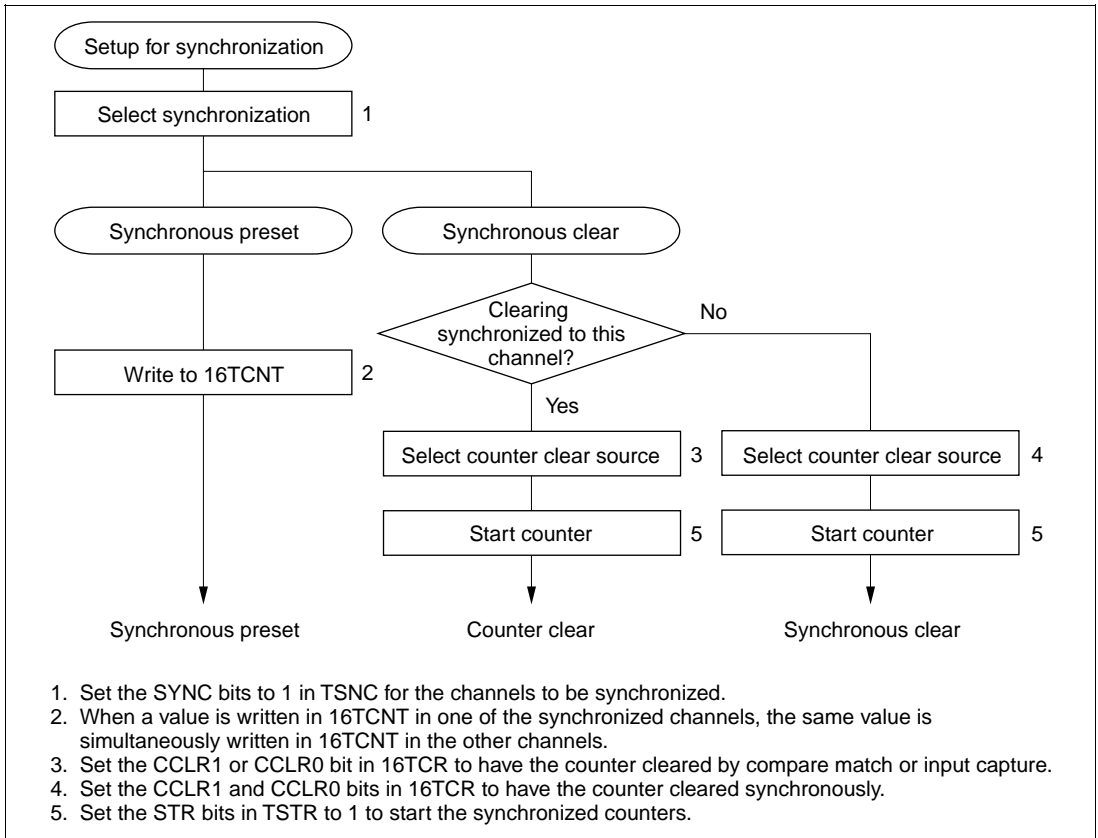

Figure 9.24 Setup Procedure for Synchronization (Example)

Example of Synchronization: Figure 9.25 shows an example of synchronization. Channels 0, 1, and 2 are synchronized, and are set to operate in PWM mode. Channel 0 is set for counter clearing by compare match with GRB0. Channels 1 and 2 are set for synchronous counter clearing. The timer counters in channels 0, 1, and 2 are synchronously preset, and are synchronously cleared by compare match with GRB0. A three-phase PWM waveform is output from pins TIOCA₀, TIOCA₁, and TIOCA₂. For further information on PWM mode, see section 9.4.4, PWM Mode.

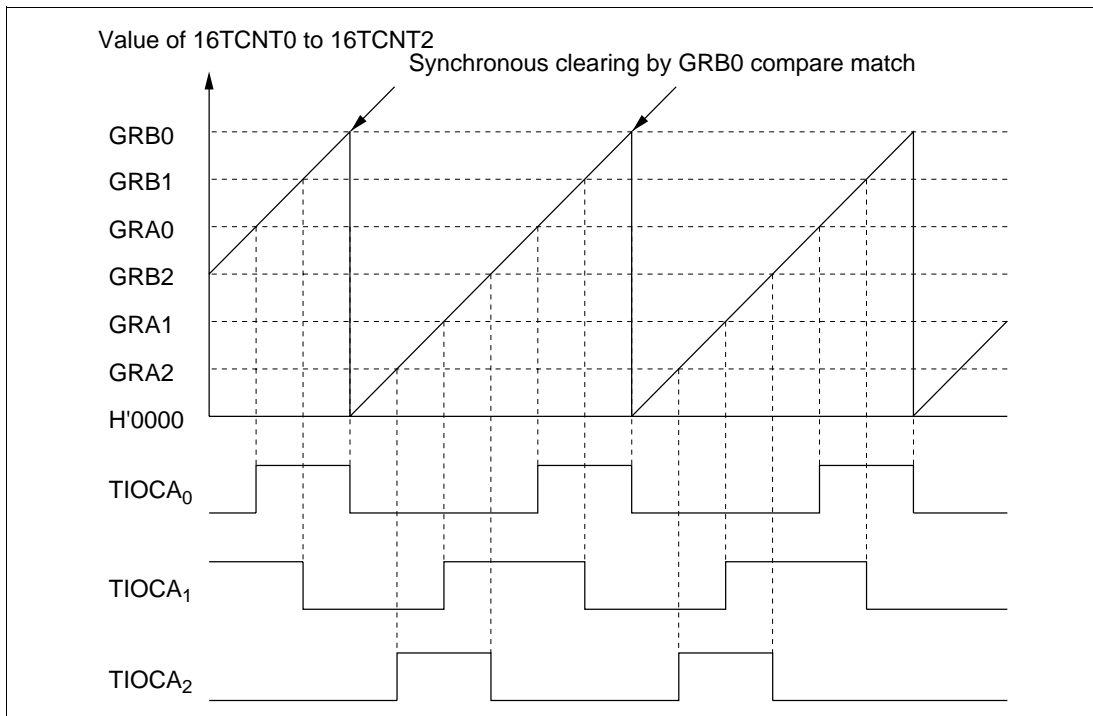

Figure 9.25 Synchronization (Example)

9.4.4 PWM Mode

In PWM mode GRA and GRB are paired and a PWM waveform is output from the TIOCA pin. GRA specifies the time at which the PWM output changes to 1. GRB specifies the time at which the PWM output changes to 0. If either GRA or GRB is selected as the counter clear source, a PWM waveform with a duty cycle from 0% to 100% is output at the TIOCA pin. PWM mode can be selected in all channels (0 to 2).

Table 9.4 summarizes the PWM output pins and corresponding registers. If the same value is set in GRA and GRB, the output does not change when compare match occurs.

Table 9.4 PWM Output Pins and Registers

Channel	Output Pin	1 Output	0 Output
0	TIOCA ₀	GRA0	GRB0
1	TIOCA ₁	GRA1	GRB1
2	TIOCA ₂	GRA2	GRB2

Sample Setup Procedure for PWM Mode: Figure 9.26 shows a sample procedure for setting up PWM mode.

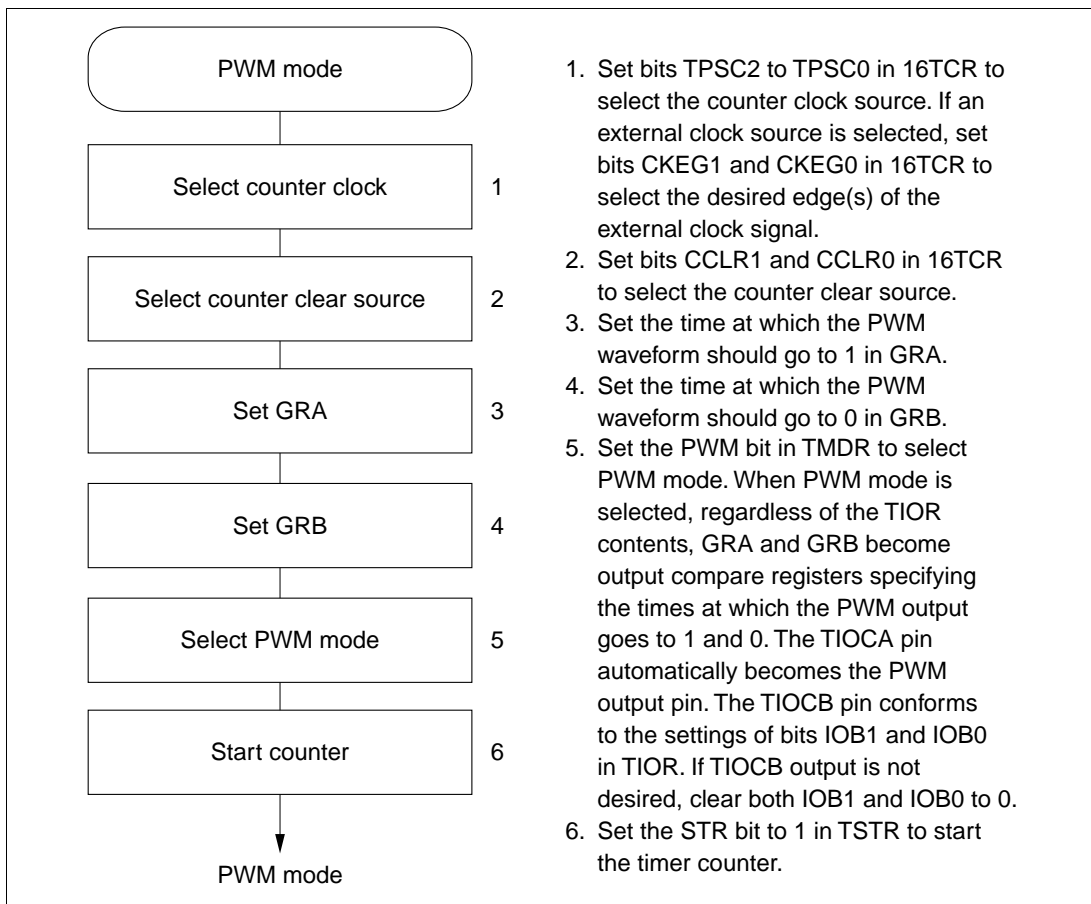

Figure 9.26 Setup Procedure for PWM Mode (Example)

Examples of PWM Mode: Figure 9.27 shows examples of operation in PWM mode. In PWM mode TIOCA becomes an output pin. The output goes to 1 at compare match with GRA, and to 0 at compare match with GRB.

In the examples shown, 16TCNT is cleared by compare match with GRA or GRB. Synchronized operation and free-running counting are also possible.

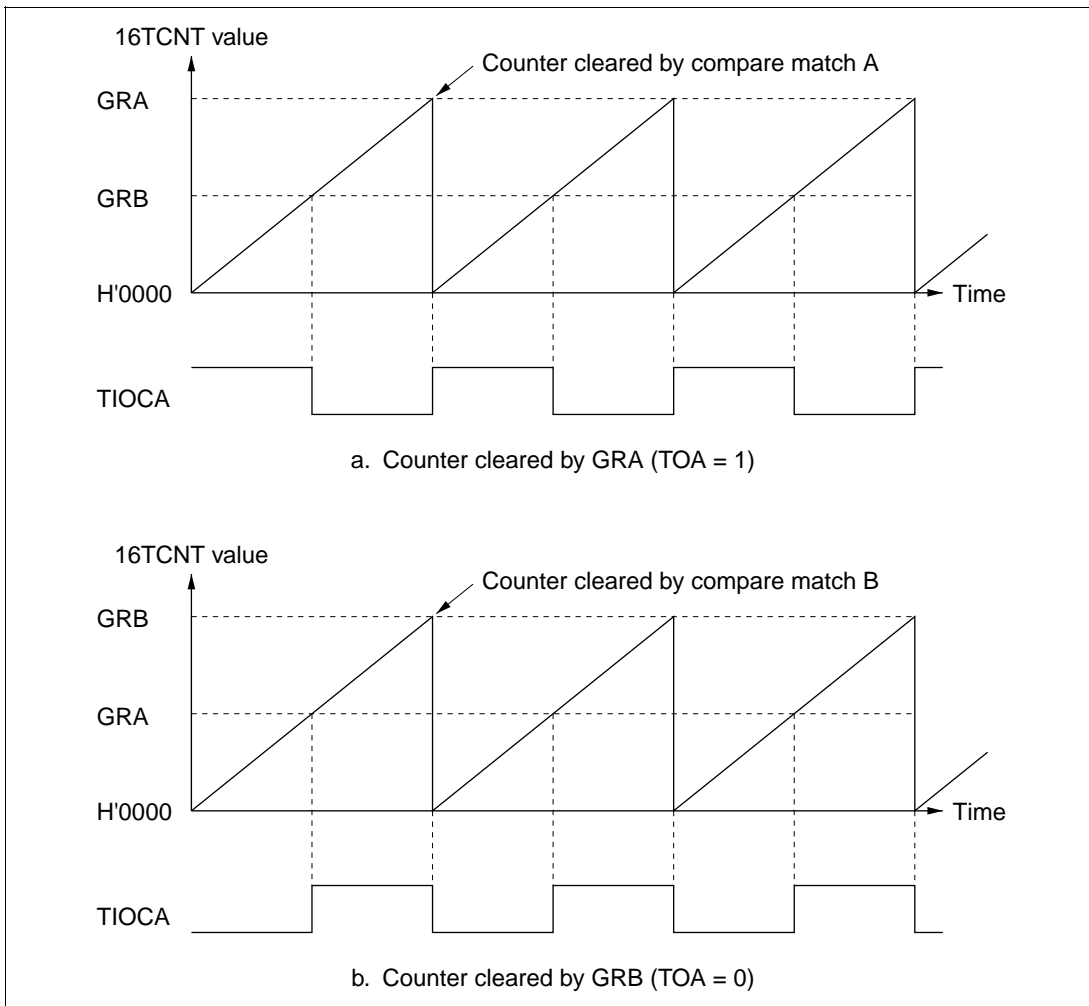

Figure 9.27 PWM Mode (Example 1)

Figure 9.28 shows examples of the output of PWM waveforms with duty cycles of 0% and 100%. If the counter is cleared by compare match with GRB, and GRA is set to a higher value than GRB, the duty cycle is 0%. If the counter is cleared by compare match with GRA, and GRB is set to a higher value than GRA, the duty cycle is 100%.

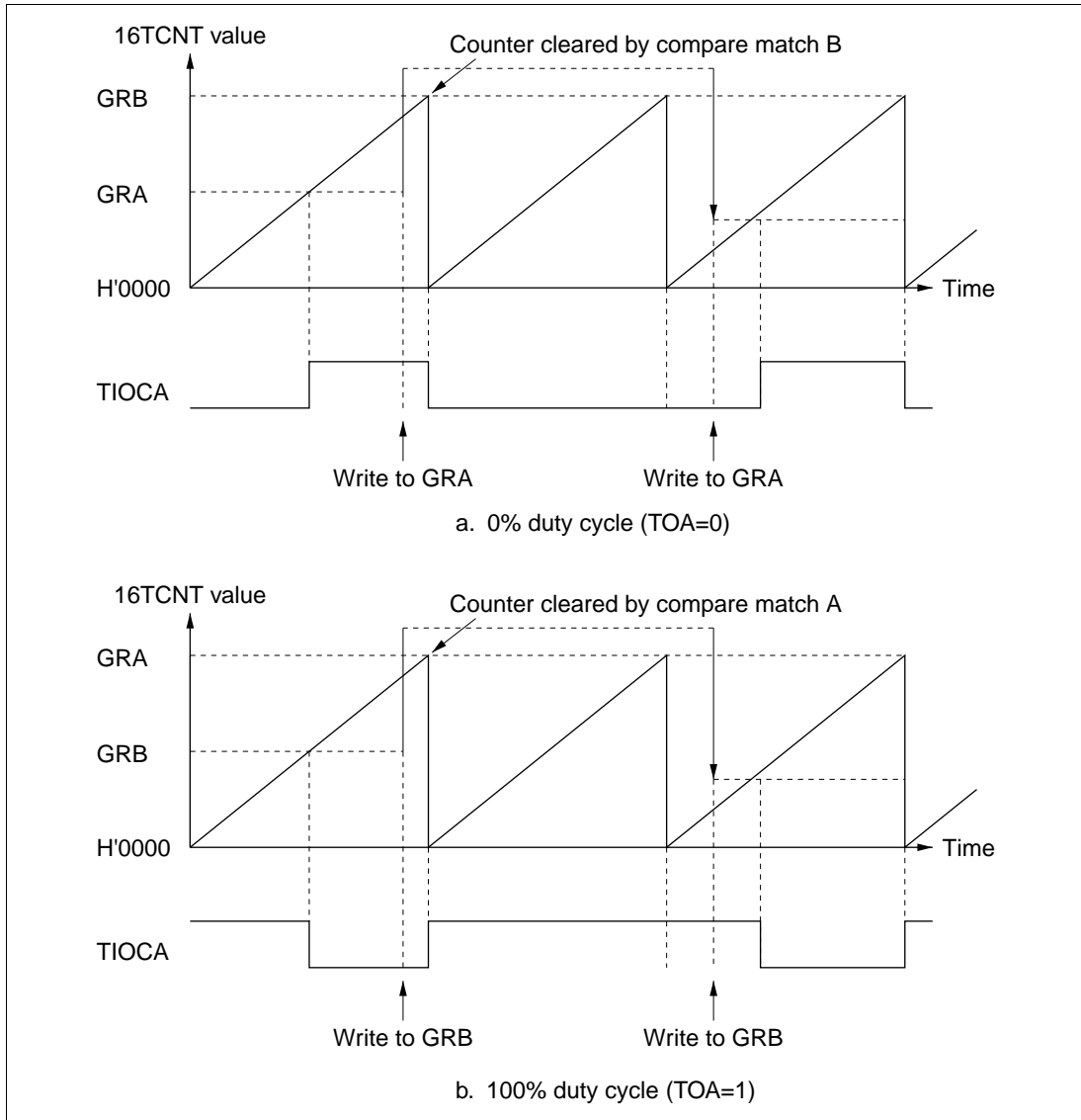

Figure 9.28 PWM Mode (Example 2)

9.4.5 Phase Counting Mode

In phase counting mode the phase difference between two external clock inputs (at the TCLKA and TCLKB pins) is detected, and 16TCNT2 counts up or down accordingly.

In phase counting mode, the TCLKA and TCLKB pins automatically function as external clock input pins and 16TCNT2 becomes an up/down-counter, regardless of the settings of bits TPSC2 to TPSC0, CKEG1, and CKEG0 in 16TCR2. Settings of bits CCLR1, CCLR0 in 16TCR2, and settings in TIOR2, TISRA, TISRB, TISRC, STR2 in TSTR, GRA2, and GRB2 are valid. The input capture and output compare functions can be used, and interrupts can be generated.

Phase counting is available only in channel 2.

Sample Setup Procedure for Phase Counting Mode: Figure 9.29 shows a sample procedure for setting up phase counting mode.

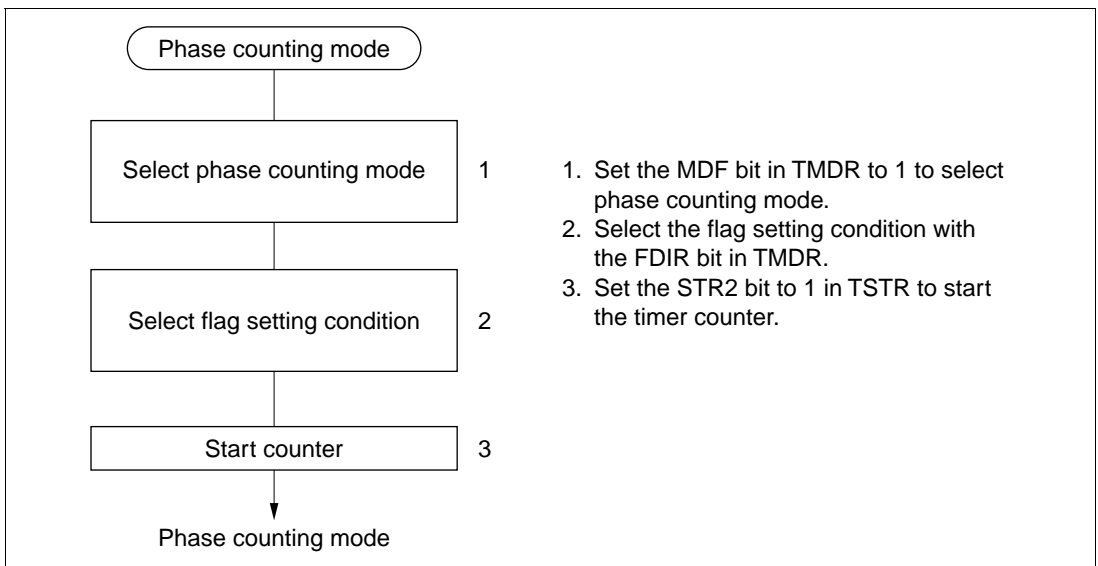

Figure 9.29 Setup Procedure for Phase Counting Mode (Example)

Example of Phase Counting Mode: Figure 9.30 shows an example of operations in phase counting mode. Table 9.5 lists the up-counting and down-counting conditions for 16TCNT2.

In phase counting mode both the rising and falling edges of TCLKA and TCLKB are counted. The phase difference between TCLKA and TCLKB must be at least 1.5 states, the phase overlap must also be at least 1.5 states, and the pulse width must be at least 2.5 states.

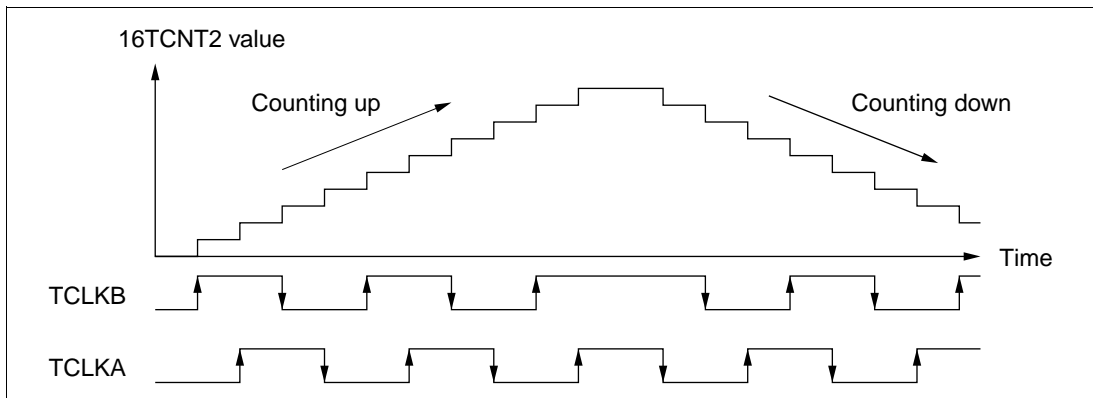

Figure 9.30 Operation in Phase Counting Mode (Example)

Table 9.5 Up/Down Counting Conditions

Counting Direction	Up-Counting				Down-Counting			
TCLKB pin		High		Low	High		Low	
TCLKA pin	Low		High			Low		High

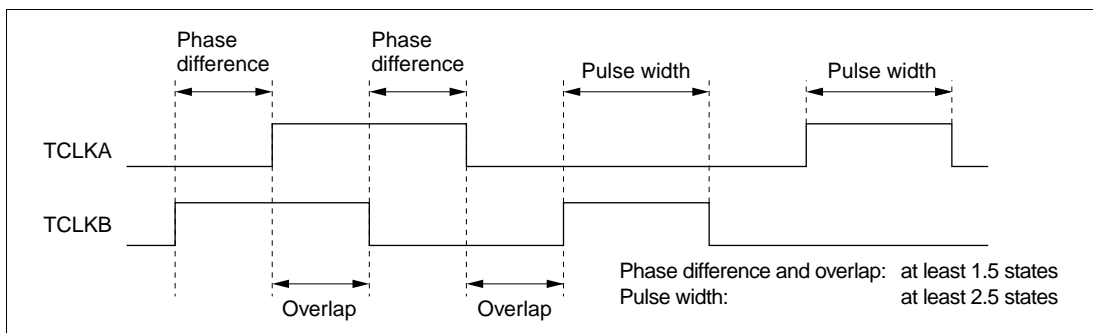

Figure 9.31 Phase Difference, Overlap, and Pulse Width in Phase Counting Mode

9.4.6 Setting Initial Value of 16-Bit Timer Output

Any desired value can be specified for the initial 16-bit timer output value when a timer count operation is started by making a setting in TOLR.

Figure 9.32 shows the timing for setting the initial output value with TOLR.

Only write to TOLR when the corresponding bit in TSTR is cleared to 0.

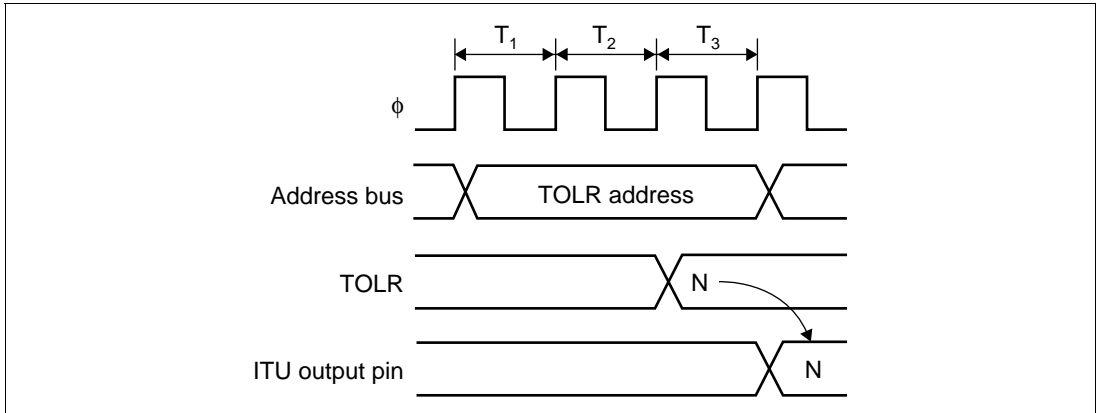

Figure 9.32 Example of Timing for Setting Initial Value of 16-Bit Timer Output by Writing to TOLR

9.5 Interrupts

The 16-bit timer has two types of interrupts: input capture/compare match interrupts, and overflow interrupts.

9.5.1 Setting of Status Flags

Timing of Setting of IMFA and IMFB at Compare Match: IMFA and IMFB are set to 1 by a compare match signal generated when 16TCNT matches a general register (GR). The compare match signal is generated in the last state in which the values match (when 16TCNT is updated from the matching count to the next count). Therefore, when 16TCNT matches a general register, the compare match signal is not generated until the next 16TCNT clock input. Figure 9.33 shows the timing of the setting of IMFA and IMFB.

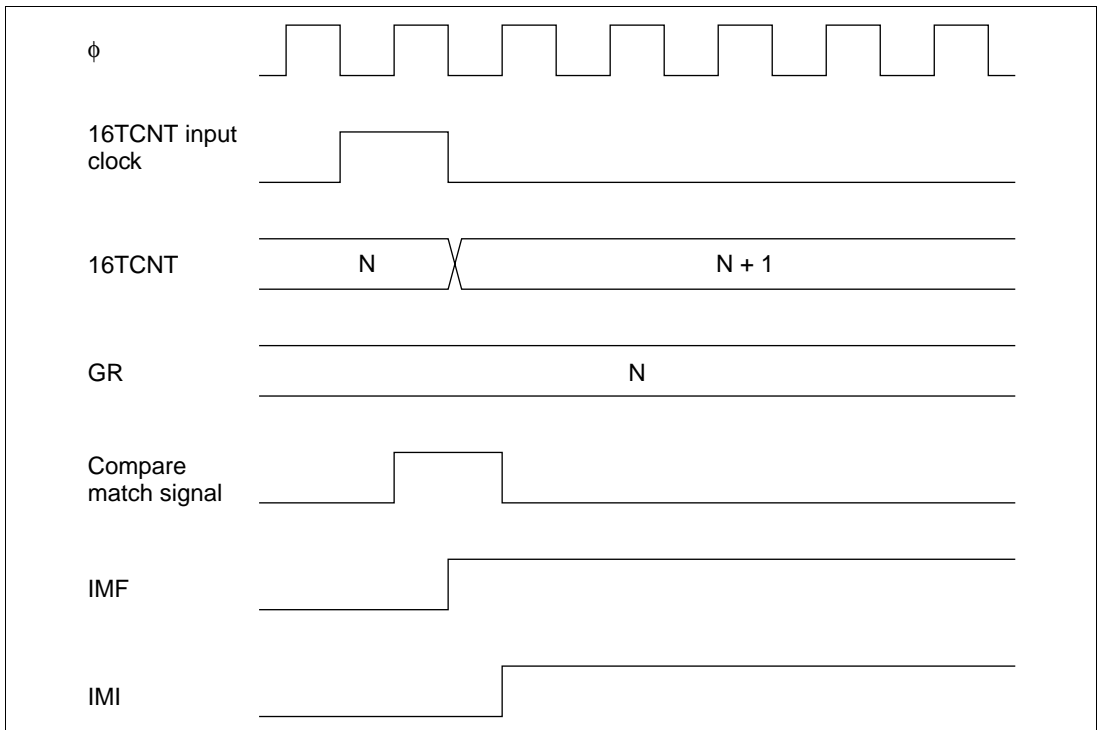

Figure 9.33 Timing of Setting of IMFA and IMFB by Compare Match

Timing of Setting of IMFA and IMFB by Input Capture: IMFA and IMFB are set to 1 by an input capture signal. The 16TCNT contents are simultaneously transferred to the corresponding general register. Figure 9.34 shows the timing.

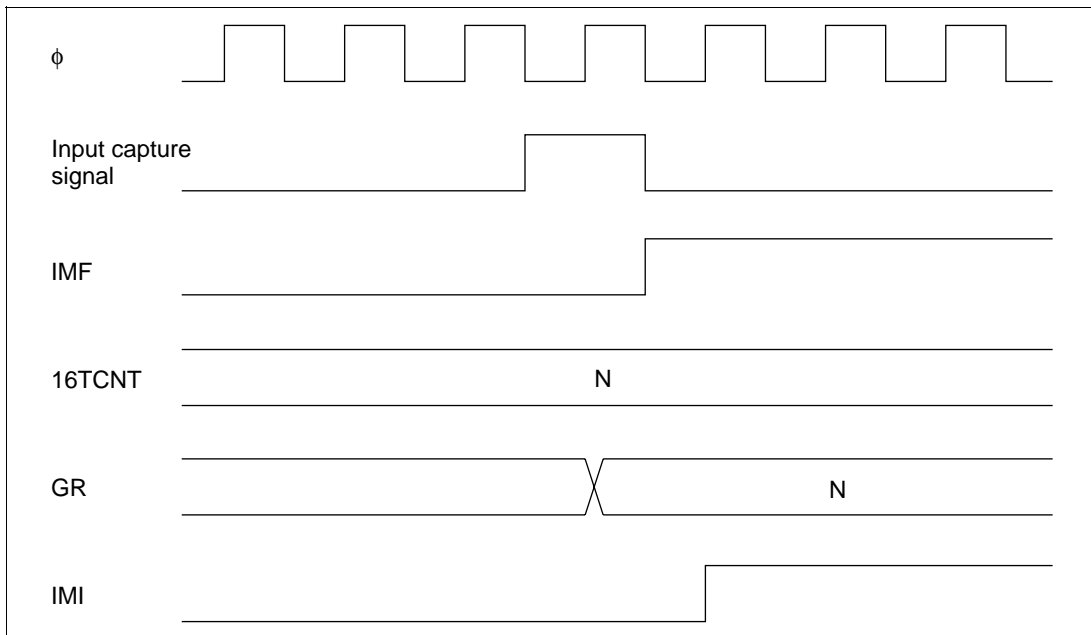

Figure 9.34 Timing of Setting of IMFA and IMFB by Input Capture

Timing of Setting of Overflow Flag (OVF): OVF is set to 1 when 16TCNT overflows from H'FFFF to H'0000 or underflows from H'0000 to H'FFFF. Figure 9.35 shows the timing.

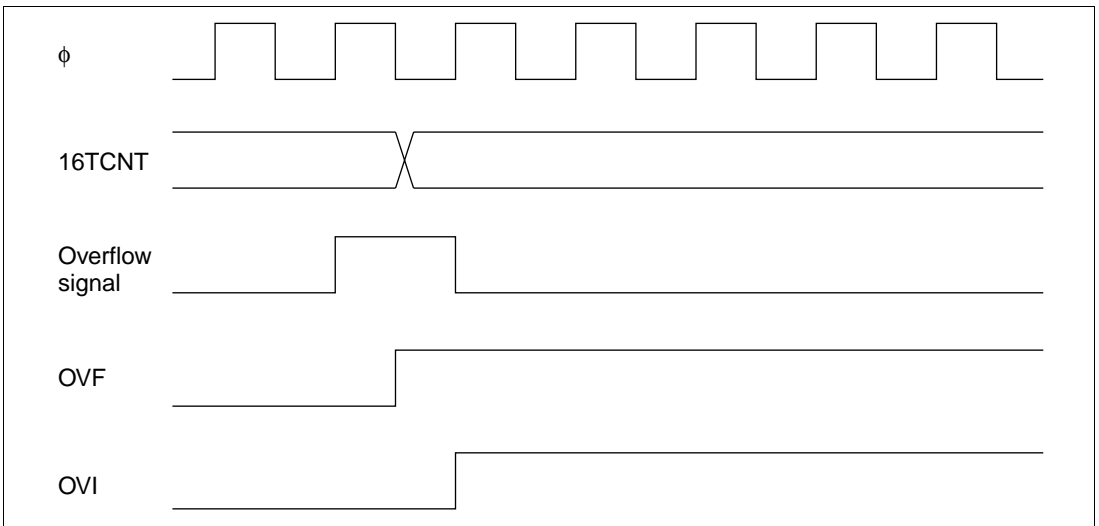

Figure 9.35 Timing of Setting of OVF

9.5.2 Timing of Clearing of Status Flags

If the CPU reads a status flag while it is set to 1, then writes 0 in the status flag, the status flag is cleared. Figure 9.36 shows the timing.

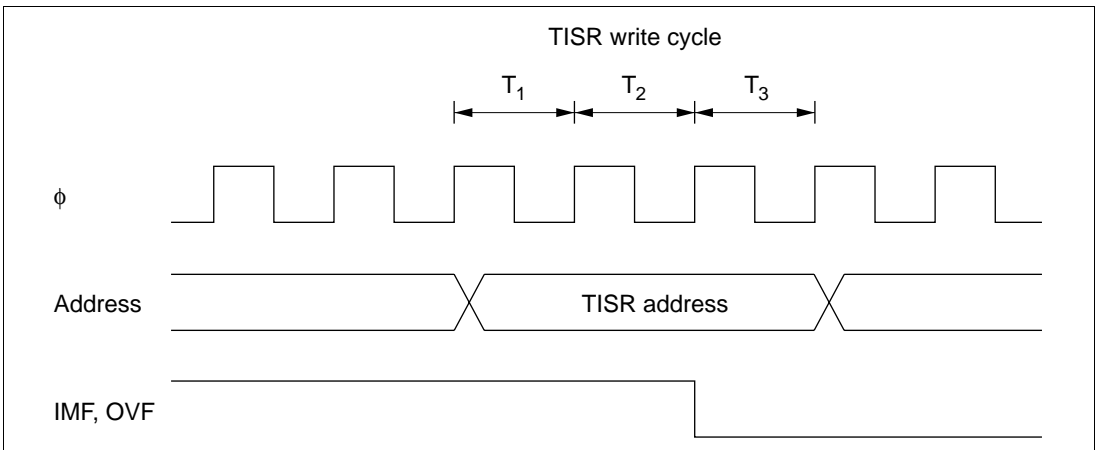

Figure 9.36 Timing of Clearing of Status Flags

9.5.3 Interrupt Sources and DMA Controller Activation

Each 16-bit timer channel can generate a compare match/input capture A interrupt, a compare match/input capture B interrupt, and an overflow interrupt. In total there are nine interrupt sources of three kinds, all independently vectored. An interrupt is requested when the interrupt request flag are set to 1.

The priority order of the channels can be modified in interrupt priority register A (IPRA). For details see section 5, Interrupt Controller.

Compare match/input capture A interrupts in channels 0 to 2 can activate the DMA controller (DMAC). When the DMAC is activated a CPU interrupt is not requested.

Table 9.6 lists the interrupt sources.

Table 9.6 16-bit timer Interrupt Sources

Channel	Interrupt Source	Description	DMAC Activatable	Priority*
0	IMIA0	Compare match/input capture A0	Yes	High ↑ Low
	IMIB0	Compare match/input capture B0	No	
	OVI0	Overflow 0	No	
1	IMIA1	Compare match/input capture A1	Yes	
	IMIB1	Compare match/input capture B1	No	
	OVI1	Overflow 1	No	
2	IMIA2	Compare match/input capture A2	Yes	
	IMIB2	Compare match/input capture B2	No	
	OVI2	Overflow 2	No	

Note: * The priority immediately after a reset is indicated. Inter-channel priorities can be changed by settings in IPRA.

9.6 Usage Notes

This section describes contention and other matters requiring special attention during 16-bit timer operations.

Contention between 16TCNT Write and Clear: If a counter clear signal occurs in the T_3 state of a 16TCNT write cycle, clearing of the counter takes priority and the write is not performed. See figure 9.37.

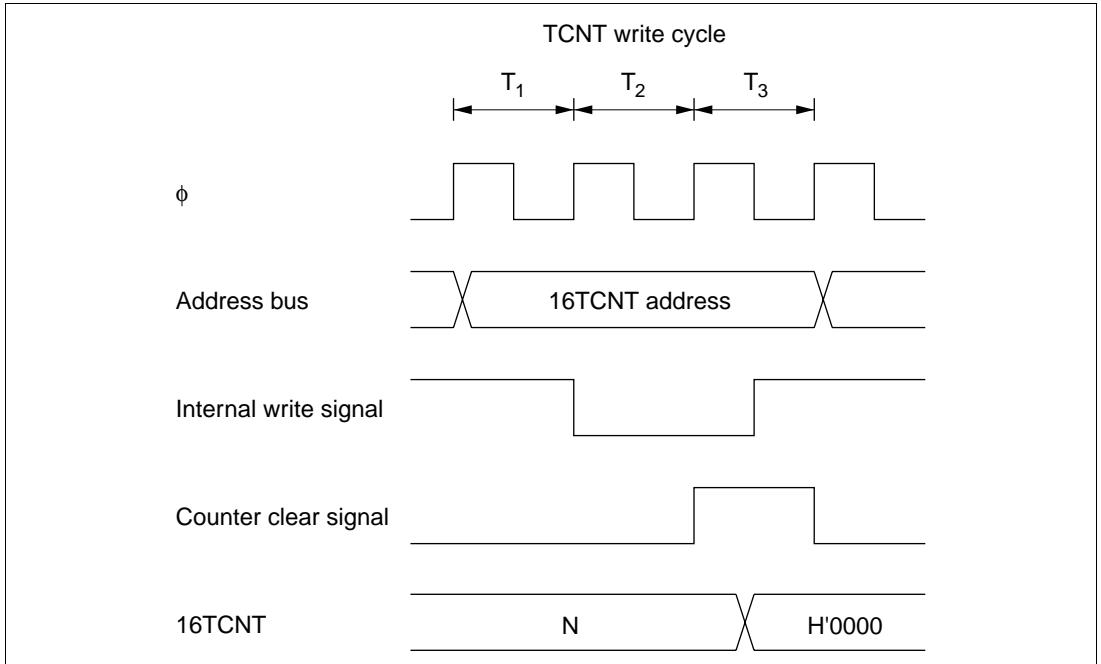

Figure 9.37 Contention between 16TCNT Write and Clear

Contention between 16TCNT Word Write and Increment: If an increment pulse occurs in the T_3 state of a 16TCNT word write cycle, writing takes priority and 16TCNT is not incremented. Figure 9.38 shows the timing in this case.

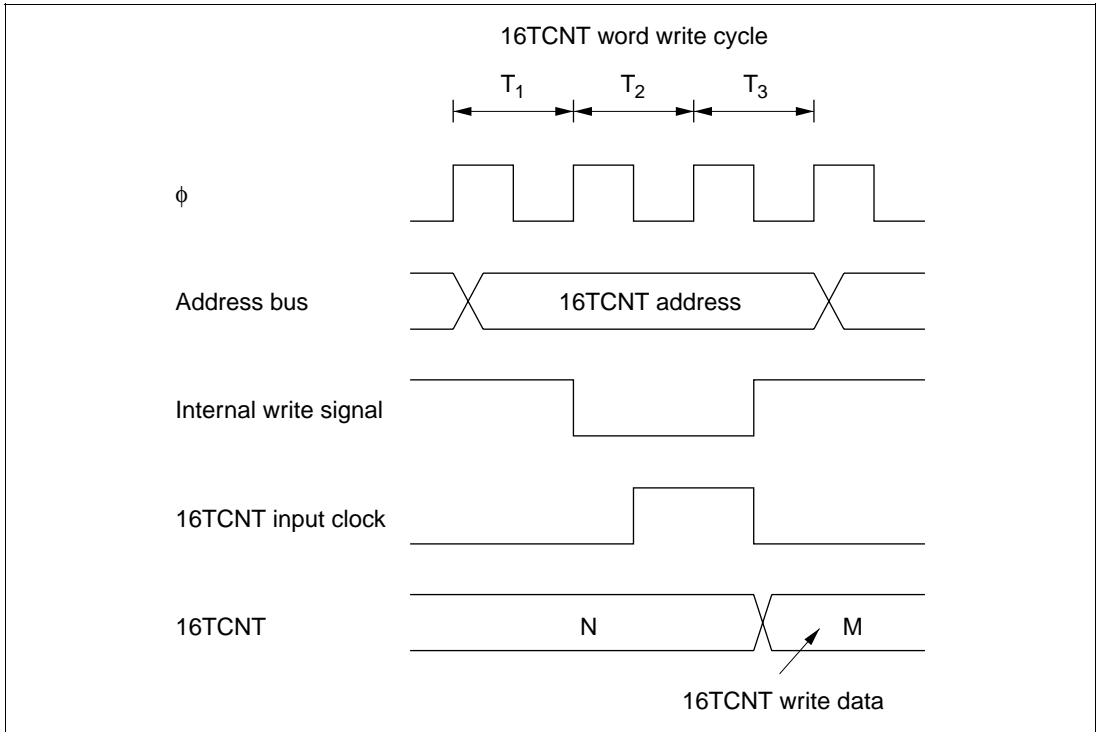

Figure 9.38 Contention between 16TCNT Word Write and Increment

Contention between 16TCNT Byte Write and Increment: If an increment pulse occurs in the T_2 or T_3 state of a 16TCNT byte write cycle, writing takes priority and 16TCNT is not incremented. The 16TCNT byte that was not written retains its previous value. See figure 9.39, which shows an increment pulse occurring in the T_2 state of a byte write to 16TCNTH.

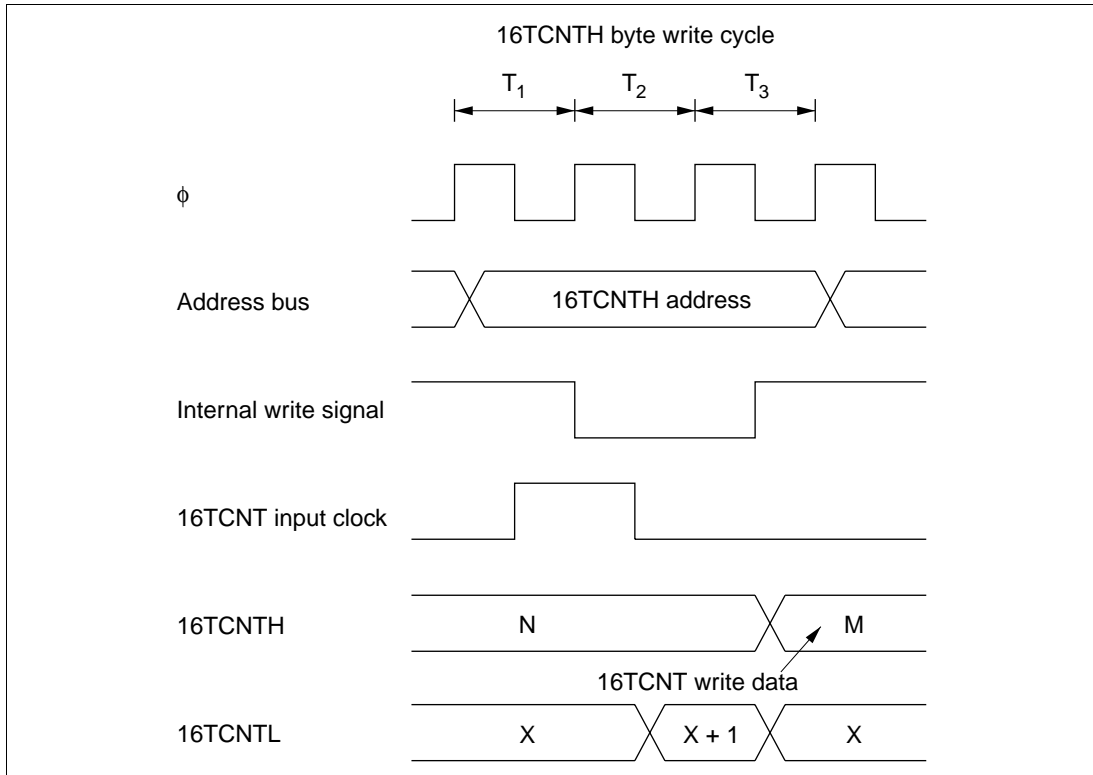

Figure 9.39 Contention between 16TCNT Byte Write and Increment

Contention between General Register Write and Compare Match: If a compare match occurs in the T_3 state of a general register write cycle, writing takes priority and the compare match signal is inhibited. See figure 9.40.

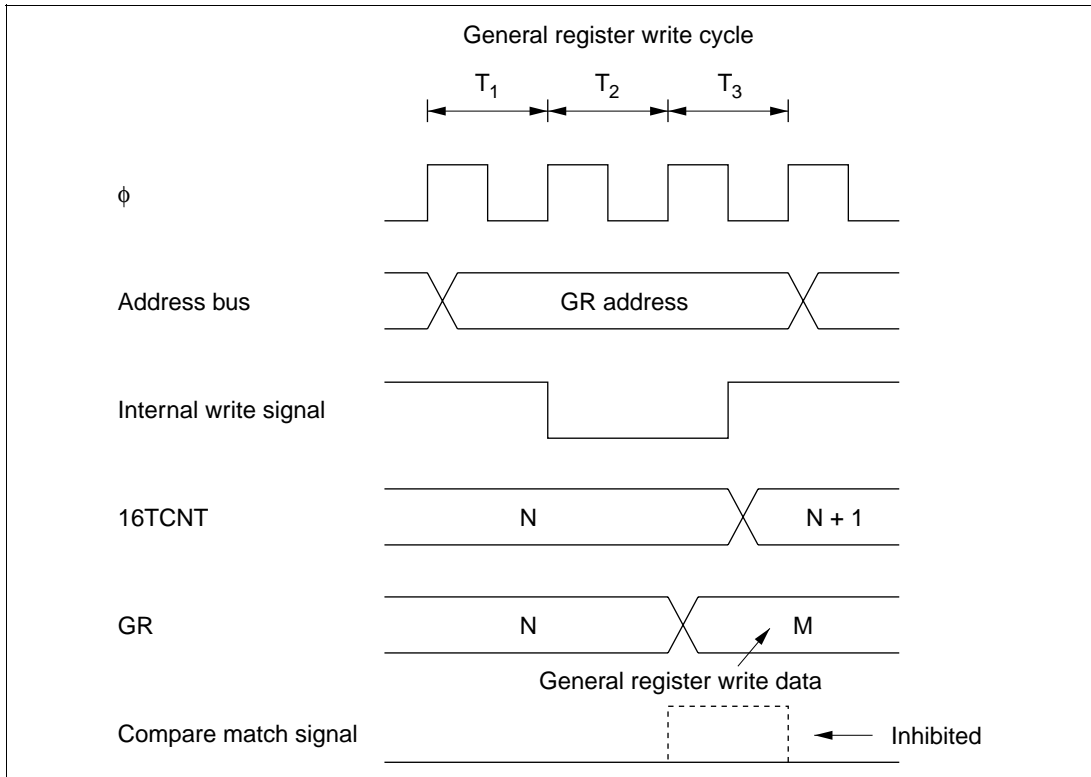

Figure 9.40 Contention between General Register Write and Compare Match

Contention between 16TCNT Write and Overflow or Underflow: If an overflow occurs in the T_3 state of a 16TCNT write cycle, writing takes priority and the counter is not incremented. OVF is set to 1. The same holds for underflow. See figure 9.41.

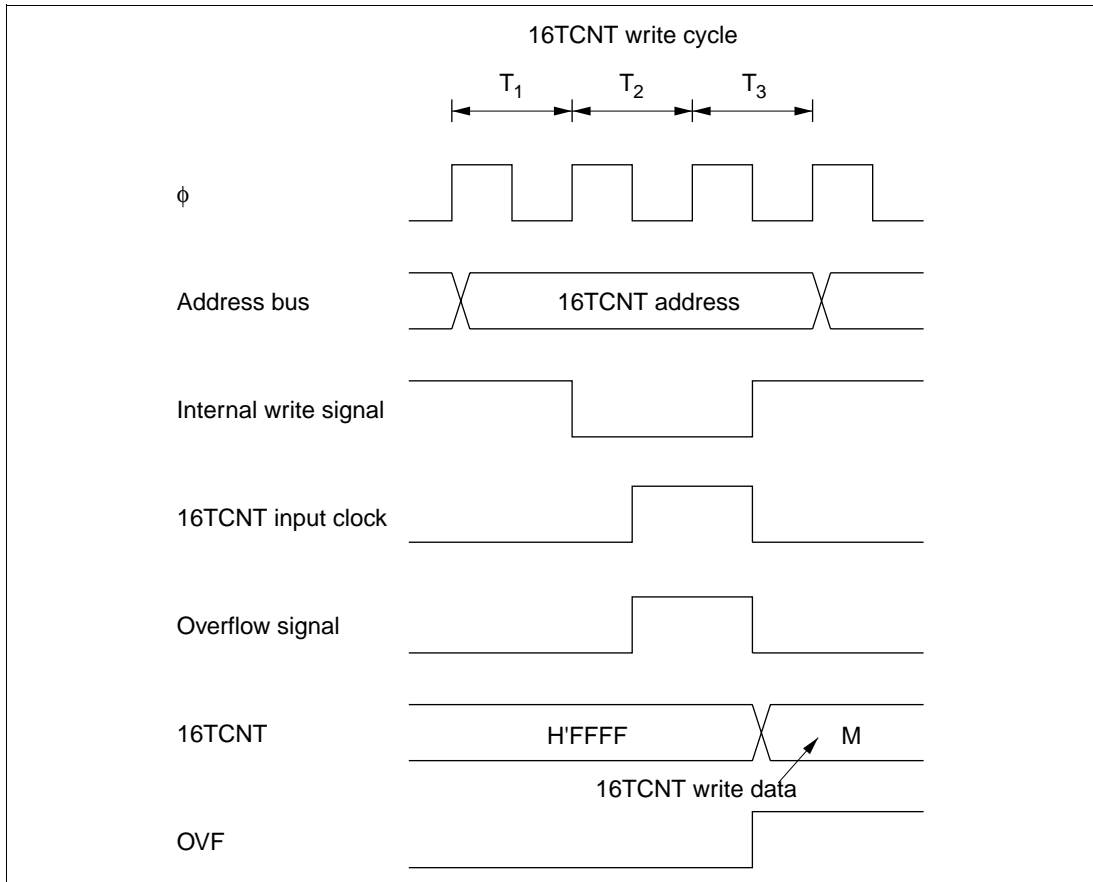

Figure 9.41 Contention between 16TCNT Write and Overflow

Contention between General Register Read and Input Capture: If an input capture signal occurs during the T_3 state of a general register read cycle, the value before input capture is read. See figure 9.42.

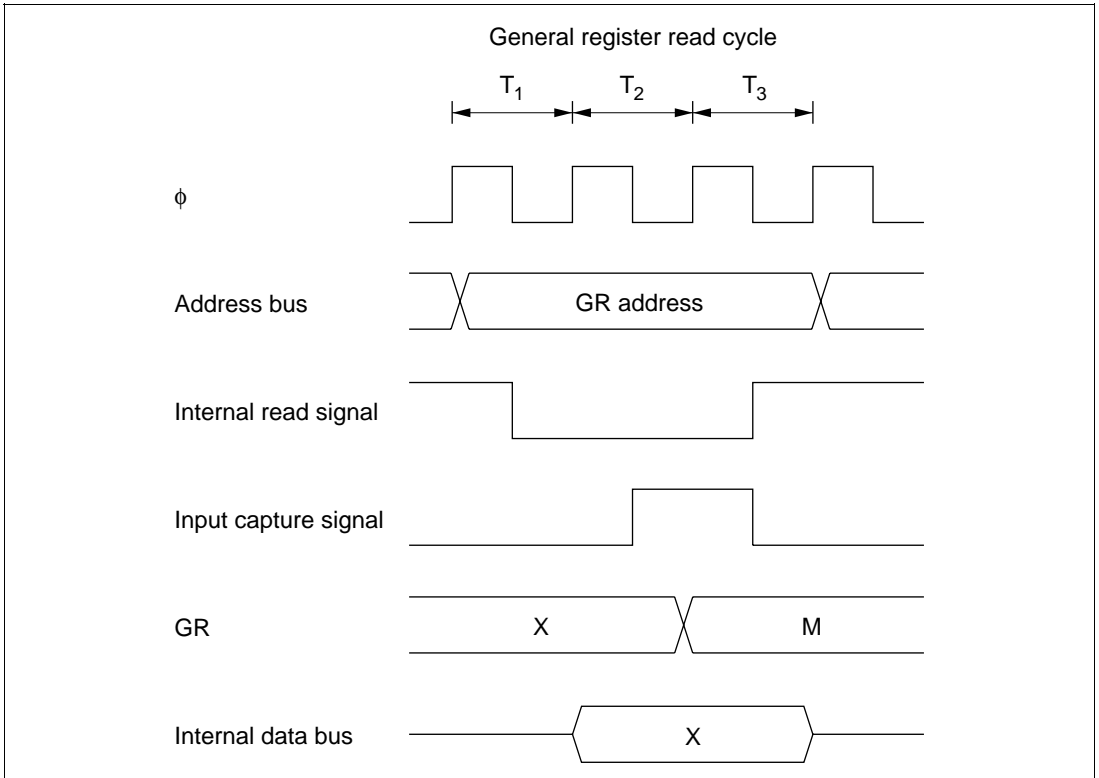

Figure 9.42 Contention between General Register Read and Input Capture

Contention between Counter Clearing by Input Capture and Counter Increment: If an input capture signal and counter increment signal occur simultaneously, the counter is cleared according to the input capture signal. The counter is not incremented by the increment signal. The value before the counter is cleared is transferred to the general register. See figure 9.43.

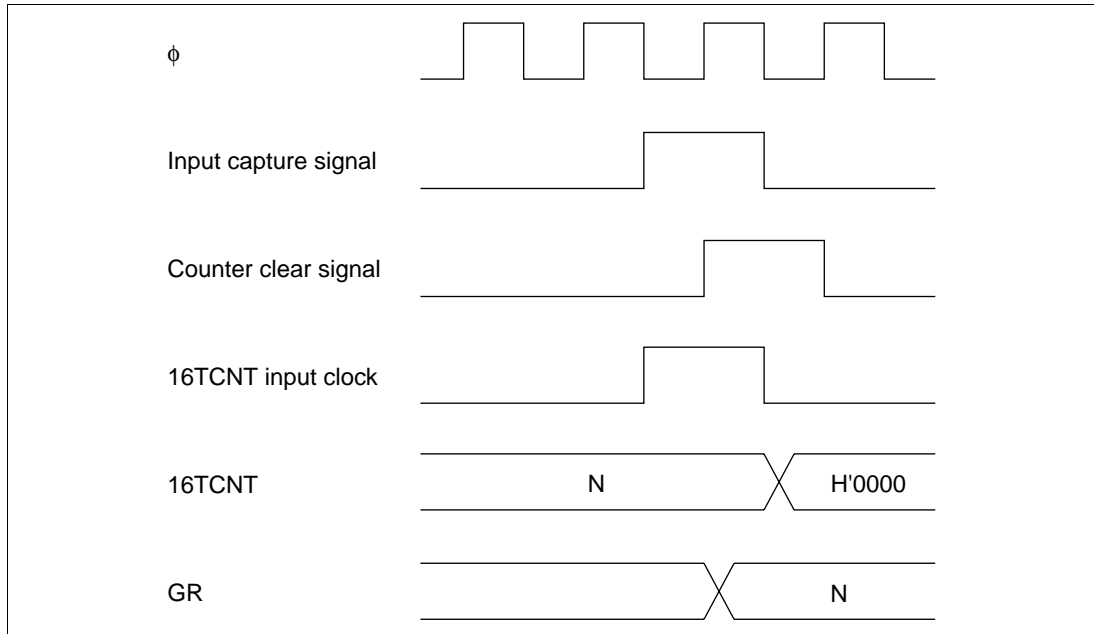

Figure 9.43 Contention between Counter Clearing by Input Capture and Counter Increment

Contention between General Register Write and Input Capture: If an input capture signal occurs in the T₃ state of a general register write cycle, input capture takes priority and the write to the general register is not performed. See figure 9.44.

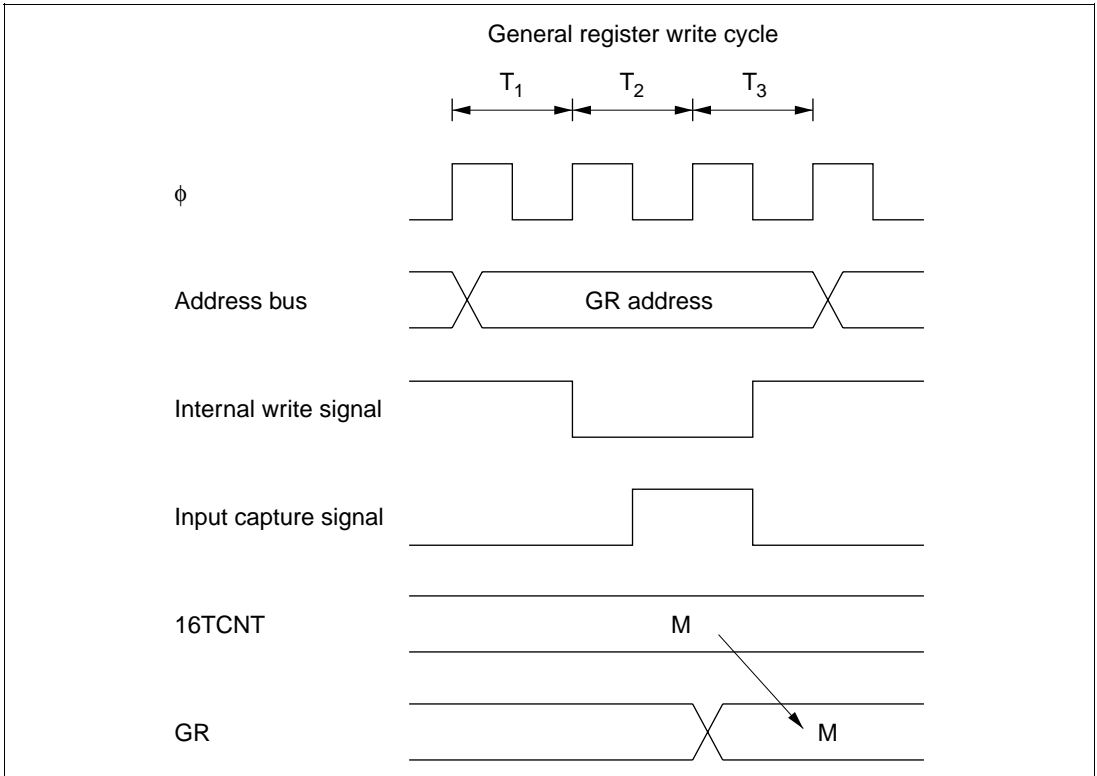

Figure 9.44 Contention between General Register Write and Input Capture

Note on Waveform Period Setting: When a counter is cleared by compare match, the counter is cleared in the last state at which the 16TCNT value matches the general register value, at the time when this value would normally be updated to the next count. The actual counter frequency is therefore given by the following formula:

$$f = \frac{\phi}{(N+1)}$$

(f: counter frequency. ϕ : system clock frequency. N: value set in general register.)

Note on Writes in Synchronized Operation: When channels are synchronized, if a 16TCNT value is modified by byte write access, all 16 bits of all synchronized counters assume the same value as the counter that was addressed.

(Example) When channels 1 and 2 are synchronized

- Byte write to channel 1 or byte write to channel 2

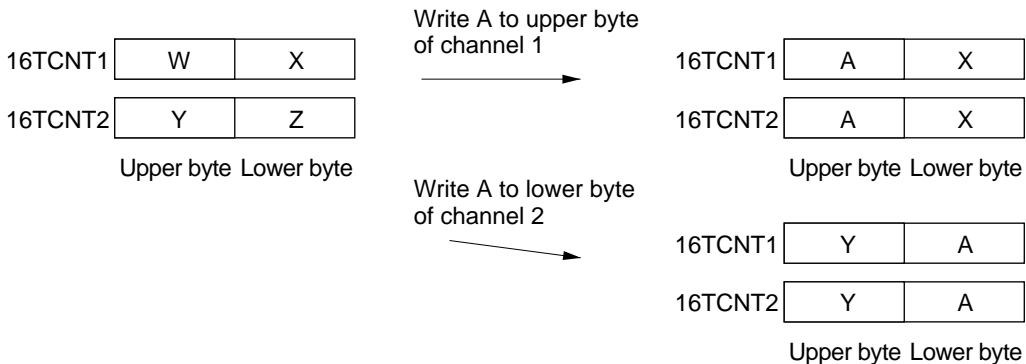

- Word write to channel 1 or word write to channel 2

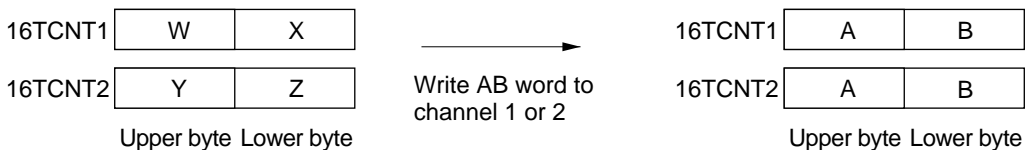

16-bit timer Operating Modes

Table 9.7 (a) 16-bit timer Operating Modes (Channel 0)

Operating Mode		Register Settings							
		TSNC	TMDR			TIOR0		TCR0	
		Synchro- nization	MDF	FDIR	PWM	IOA	IOB	Clear Select	Clock Select
Synchronous preset		SYNC0 = 1	—	—	○	○	○	○	○
PWM mode		○	—	—	PWM0 = 1	—	○*	○	○
Output compare A		○	—	—	PWM0 = 0	IOA2 = 0 Other bits unrestricted	○	○	○
Output compare B		○	—	—	○	○	IOB2 = 0 Other bits unrestricted	○	○
Input capture A		○	—	—	PWM0 = 0	IOA2 = 1 Other bits unrestricted	○	○	○
Input capture B		○	—	—	PWM0 = 0	○	IOB2 = 1 Other bits unrestricted	○	○
Counter clearing	By compare match/input capture A	○	—	—	○	○	○	CCLR1 = 0 CCLR0 = 1	○
	By compare match/input capture B	○	—	—	○	○	○	CCLR1 = 1 CCLR0 = 0	○
	Syn- chronous clear	SYNC0 = 1	—	—	○	○	○	CCLR1 = 1 CCLR0 = 1	○

Legend: ○ Setting available (valid). — Setting does not affect this mode.

Note: * The input capture function cannot be used in PWM mode. If compare match A and compare match B occur simultaneously, the compare match signal is inhibited.

Table 9.7 (b) 16-bit timer Operating Modes (Channel 1)

Operating Mode		Register Settings							
		TSNC	TMDR			TIOR1		TCR1	
		Synchro- nization	MDF	FDIR	PWM	IOA	IOB	Clear Select	Clock Select
Synchronous preset		SYNC1 = 1	—	—	○	○	○	○	○
PWM mode		○	—	—	PWM1 = 1	—	○*	○	○
Output compare A		○	—	—	PWM1 = 0	IOA2 = 0 Other bits unrestricted	○	○	○
Output compare B		○	—	—	○	○	IOB2 = 0 Other bits unrestricted	○	○
Input capture A		○	—	—	PWM1 = 0	IOA2 = 1 Other bits unrestricted	○	○	○
Input capture B		○	—	—	PWM1 = 0	○	IOB2 = 1 Other bits unrestricted	○	○
Counter clearing	By compare match/input capture A	○	—	—	○	○	○	CCLR1 = 0 CCLR0 = 1	○
	By compare match/input capture B	○	—	—	○	○	○	CCLR1 = 1 CCLR0 = 0	○
	Syn- chronous clear	SYNC1 = 1	—	—	○	○	○	CCLR1 = 1 CCLR0 = 1	○

Legend: ○ Setting available (valid). — Setting does not affect this mode.

Notes: * The input capture function cannot be used in PWM mode. If compare match A and compare match B occur simultaneously, the compare match signal is inhibited.

Table 9.7 (c) 16-bit timer Operating Modes (Channel 2)

Operating Mode		Register Settings							
		TSNC	TMDR			TIOR2		TCR2	
		Synchro- nization	MDF	FDIR	PWM	IOA	IOB	Clear Select	Clock Select
Synchronous preset		SYNC2 = 1	○	—	○	○	○	○	○
PWM mode		○	○	—	PWM2 = 1	—	○*	○	○
Output compare A		○	○	—	PWM2 = 0	IOA2 = 0 Other bits unrestricted	○	○	○
Output compare B		○	○	—	○	○	IOB2 = 0 Other bits unrestricted	○	○
Input capture A		○	○	—	PWM2 = 0	IOA2 = 1 Other bits unrestricted	○	○	○
Input capture B		○	○	—	PWM2 = 0	○	IOB2 = 1 Other bits unrestricted	○	○
Counter clearing	By compare match/input capture A	○	○	—	○	○	○	CCLR1 = 0 CCLR0 = 1	○
	By compare match/input capture B	○	○	—	○	○	○	CCLR1 = 1 CCLR0 = 0	○
	Syn-chronous clear	SYNC2 = 1	○	—	○	○	○	CCLR1 = 1 CCLR0 = 1	○
Phase counting mode		○	MDF = 1	○	○	○	○	○	—

Legend: ○ Setting available (valid). — Setting does not affect this mode.

Note: * The input capture function cannot be used in PWM mode. If compare match A and compare match B occur simultaneously, the compare match signal is inhibited.

Section 10 8-Bit Timers

10.1 Overview

The H8/3006 and H8/3007 have a built-in 8-bit timer module with four channels (TMR0, TMR1, TMR2, and TMR3), based on 8-bit counters. Each channel has an 8-bit timer counter (8TCNT) and two 8-bit time constant registers (TCORA and TCORB) that are constantly compared with the 8TCNT value to detect compare match events. The timers can be used as multifunctional timers in a variety of applications, including the generation of a rectangular-wave output with an arbitrary duty cycle.

10.1.1 Features

The features of the 8-bit timer module are listed below.

- Selection of four clock sources
The counters can be driven by one of three internal clock signals ($\phi/8$, $\phi/64$, or $\phi/8192$) or an external clock input (enabling use as an external event counter).
- Selection of three ways to clear the counters
The counters can be cleared on compare match A or B, or input capture B.
- Timer output controlled by two compare match signals
The timer output signal in each channel is controlled by two independent compare match signals, enabling the timer to generate output waveforms with an arbitrary duty cycle or PWM output.
- A/D converter can be activated by a compare match
- Two channels can be cascaded
 - Channels 0 and 1 can be operated as the upper and lower halves of a 16-bit timer (16-bit count mode).
 - Channels 2 and 3 can be operated as the upper and lower halves of a 16-bit timer (16-bit count mode).
 - Channel 1 can count channel 0 compare match events (compare match count mode).
 - Channel 3 can count channel 2 compare match events (compare match count mode).
- Input capture function can be set
8-bit or 16-bit input capture operation is available.
- Twelve interrupt sources
There are twelve interrupt sources: four compare match sources, four compare match/input capture sources, four overflow sources.

Two of the compare match sources and two of the combined compare match/input capture sources each have an independent interrupt vector. The remaining compare match interrupts, combined compare match/input capture interrupts, and overflow interrupts have one interrupt vector for two sources.

10.1.2 Block Diagram

The 8-bit timers are divided into two groups of two channels each: group 0 comprising channels 0 and 1, and group 1 comprising channels 2 and 3. Figure 10.1 shows a block diagram of 8-bit timer group 0.

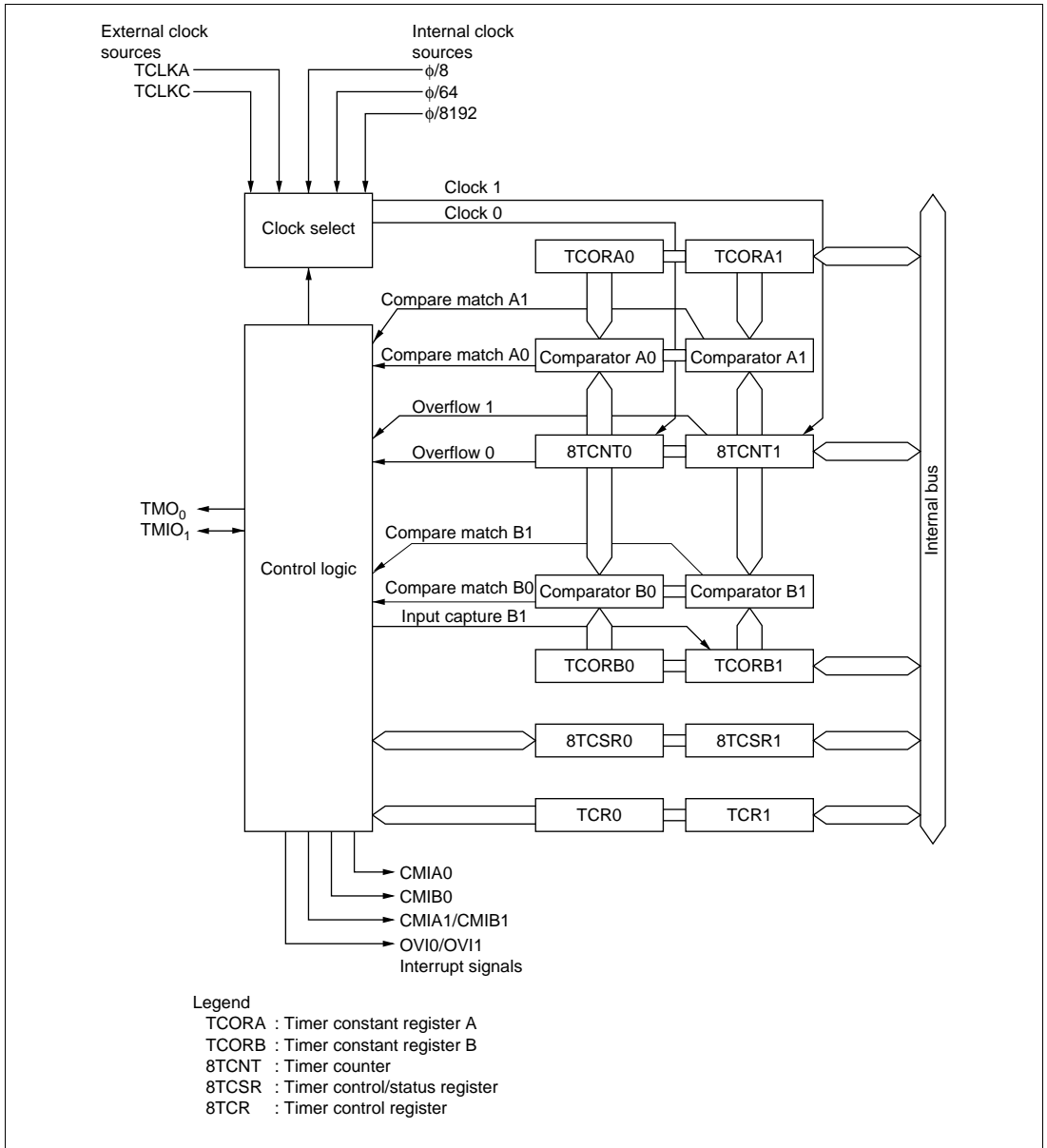

Figure 10.1 Block Diagram of 8-Bit Timer Unit (Two Channels: Group 0)

10.1.3 Pin Configuration

Table 10.1 summarizes the input/output pins of the 8-bit timer module.

Table 10.1 8-Bit Timer Pins

Group	Channel	Name	Abbreviation	I/O	Input/output
0	0	Timer output	TMO ₀	Output	Compare match output
		Timer clock input	TCLKC	Input	Counter external clock input
	1	Timer input/output	TMIO ₁	I/O	Compare match output/input capture input
		Timer clock input	TCLKA	Input	Counter external clock input
1	2	Timer output	TMO ₂	Output	Compare match output
		Timer clock input	TCLKD	Input	Counter external clock input
	3	Timer input/output	TMIO ₃	I/O	Compare match output/input capture input
		Timer clock input	TCLKB	Input	Counter external clock input

10.1.4 Register Configuration

Table 10.2 summarizes the registers of the 8-bit timer module.

Table 10.2 8-Bit Timer Registers

Channel	Address*1	Name	Abbreviation	R/W	Initial value
0	H'FFF80	Timer control register 0	8TCR0	R/W	H'00
	H'FFF82	Timer control/status register 0	8TCSR0	R/(W)*2	H'00
	H'FFF84	Timer constant register A0	TCORA0	R/W	H'FF
	H'FFF86	Timer constant register B0	TCORB0	R/W	H'FF
	H'FFF88	Timer counter 0	8TCNT0	R/W	H'00
1	H'FFF81	Timer control register 1	8TCR1	R/W	H'00
	H'FFF83	Timer control/status register 1	8TCSR1	R/(W)*2	H'00
	H'FFF85	Timer constant register A1	TCORA1	R/W	H'FF
	H'FFF87	Timer constant register B1	TCORB1	R/W	H'FF
	H'FFF89	Timer counter 1	8TCNT1	R/W	H'00
2	H'FFF90	Timer control register 2	8TCR2	R/W	H'00
	H'FFF92	Timer control/status register 2	8TCSR2	R/(W)*2	H'10
	H'FFF94	Timer constant register A2	TCORA2	R/W	H'FF
	H'FFF96	Timer constant register B2	TCORB2	R/W	H'FF
	H'FFF98	Timer counter 2	8TCNT2	R/W	H'00
3	H'FFF91	Timer control register 3	8TCR3	R/W	H'00
	H'FFF93	Timer control/status register 3	8TCSR3	R/(W)*2	H'00
	H'FFF95	Timer constant register A3	TCORA3	R/W	H'FF
	H'FFF97	Timer constant register B3	TCORB3	R/W	H'FF
	H'FFF99	Timer counter 3	8TCNT3	R/W	H'00

Notes: 1. Indicates the lower 20 bits of the address in advanced mode.

2. Only 0 can be written to bits 7 to 5, to clear these flags.

Each pair of registers for channel 0 and channel 1 comprises a 16-bit register with the channel 0 register as the upper 8 bits and the channel 1 register as the lower 8 bits, so they can be accessed together by word access.

Similarly, each pair of registers for channel 2 and channel 3 comprises a 16-bit register with the channel 2 register as the upper 8 bits and the channel 3 register as the lower 8 bits, so they can be accessed together by word access.

10.2 Register Descriptions

10.2.1 Timer Counters (8TCNT)

	8TCNT0								8TCNT1							
Bit	15	14	13	12	11	10	9	8	7	6	5	4	3	2	1	0
Initial value	0	0	0	0	0	0	0	0	0	0	0	0	0	0	0	0
Read/Write	R/W	R/W	R/W	R/W	R/W	R/W	R/W	R/W	R/W	R/W	R/W	R/W	R/W	R/W	R/W	R/W

	8TCNT2								8TCNT3							
Bit	15	14	13	12	11	10	9	8	7	6	5	4	3	2	1	0
Initial value	0	0	0	0	0	0	0	0	0	0	0	0	0	0	0	0
Read/Write	R/W	R/W	R/W	R/W	R/W	R/W	R/W	R/W	R/W	R/W	R/W	R/W	R/W	R/W	R/W	R/W

The timer counters (8TCNT) are 8-bit readable/writable up-counters that increment on pulses generated from an internal or external clock source. The clock source is selected by clock select bits 2 to 0 (CKS2 to CKS0) in the timer control register (8TCR). The CPU can always read or write to the timer counters.

The 8TCNT0 and 8TCNT1 pair, and the 8TCNT2 and 8TCNT3 pair, can each be accessed as a 16-bit register by word access.

8TCNT can be cleared by an input capture signal or compare match signal. Counter clear bits 1 and 0 (CCLR1 and CCLR0) in 8TCR select the method of clearing.

When 8TCNT overflows from H'FF to H'00, the overflow flag (OVF) in the timer control/status register (8TCSR) is set to 1.

Each 8TCNT is initialized to H'00 by a reset and in standby mode.

10.2.2 Time Constant Registers A (TCORA)

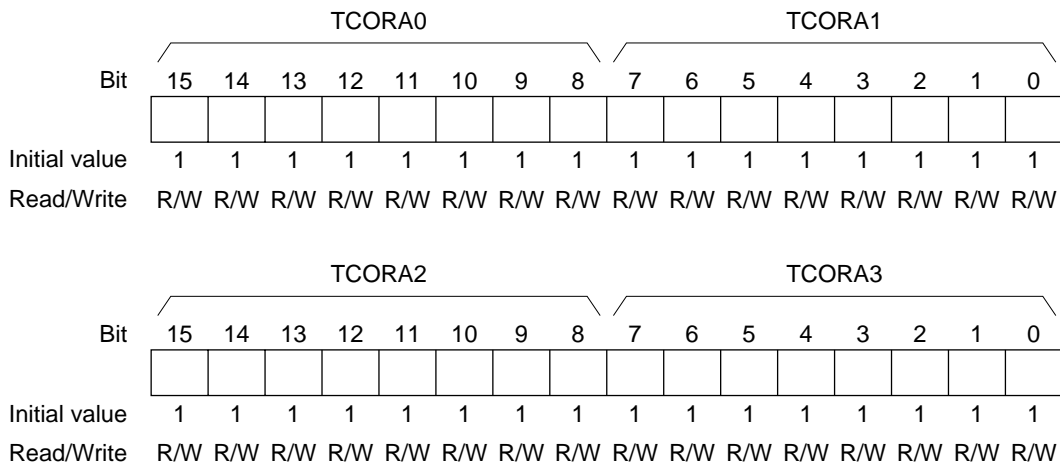

TCORA0 to TCORA3 are 8-bit readable/writable registers. The TCORA0 and TCORA1 pair, and the TCORA2 and TCORA3 pair, can each be accessed as a 16-bit register by word access.

The TCORA value is constantly compared with the 8TCNT value. When a match is detected, the corresponding compare match flag A (CMFA) is set to 1 in 8TCSR.

The timer output can be freely controlled by these compare match signals and the settings of output select bits 1 and 0 (OS1, OS0) in 8TCSR.

Each TCORA register is initialized to H'FF by a reset and in standby mode.

10.2.3 Time Constant Registers B (TCORB)

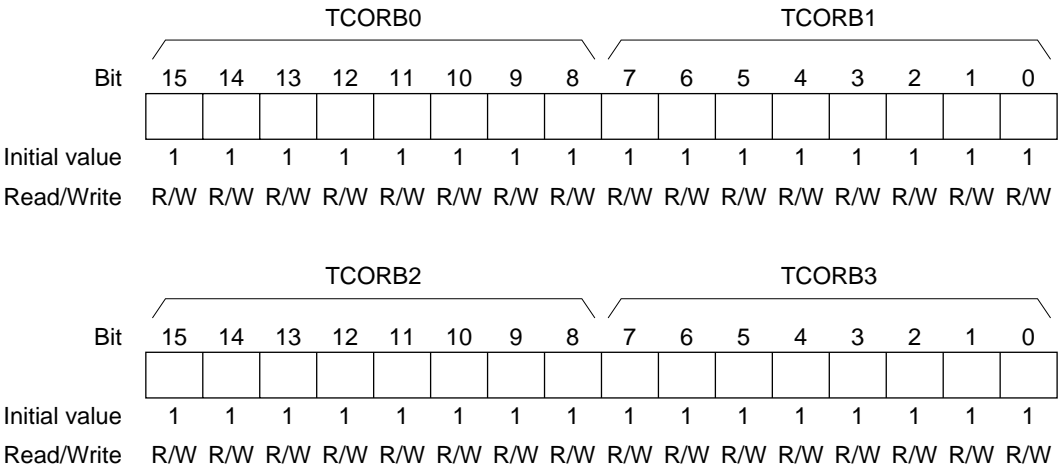

TCORB0 to TCORB3 are 8-bit readable/writable registers. The TCORB0 and TCORB1 pair, and the TCORB2 and TCORB3 pair, can each be accessed as a 16-bit register by word access.

The TCORB value is constantly compared with the 8TCNT value. When a match is detected, the corresponding compare match flag B (CMFB) is set to 1 in 8TCSR.

The timer output can be freely controlled by these compare match signals and the settings of output/input capture edge select bits 3 and 2 (OIS3, OIS2) in 8TCSR.

When TCORB is used for input capture, it stores the 8TCNT value on detection of an external input capture signal. At this time, the CMFB flag is set to 1 in the corresponding 8TCSR register. The detected edge of the input capture signal is set in 8TCSR.

Each TCORB register is initialized to H'FF by a reset and in standby mode.

10.2.4 Timer Control Register (8TCR)

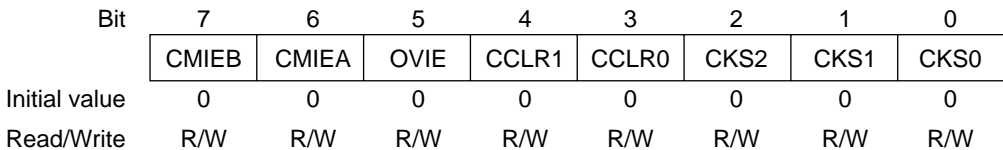

8TCR is an 8-bit readable/writable register that selects the input clock source and the time at which 8TCNT is cleared, and enables interrupts.

8TCR is initialized to H'00 by a reset and in standby mode.

For the timing, see section 10.4, Operation.

Bit 7—Compare Match Interrupt Enable B (CMIEB): Enables or disables the CMIB interrupt request when the CMFB flag is set to 1 in 8TCSR.

Bit 7 CMIEB	Description
0	CMIB interrupt requested by CMFB is disabled (Initial value)
1	CMIB interrupt requested by CMFB is enabled

Bit 6—Compare Match Interrupt Enable A (CMIEA): Enables or disables the CMIA interrupt request when the CMFA flag is set to 1 in 8TCSR.

Bit 6 CMIEA	Description
0	CMIA interrupt requested by CMFA is disabled (Initial value)
1	CMIA interrupt requested by CMFA is enabled

Bit 5—Timer Overflow Interrupt Enable (OVIE): Enables or disables the OVI interrupt request when the OVF flag is set to 1 in 8TCSR.

Bit 5 OVIE	Description
0	OVI interrupt requested by OVF is disabled (Initial value)
1	OVI interrupt requested by OVF is enabled

Bits 4 and 3—Counter Clear 1 and 0 (CCLR1 and CCLR0): These bits specify the 8TCNT clearing source. Compare match A or B, or input capture B, can be selected as the clearing source.

Bit 4 CCLR1	Bit 3 CCLR0	Description
0	0	Clearing is disabled (Initial value)
	1	Cleared by compare match A
1	0	Cleared by compare match B/input capture B
	1	Cleared by input capture B

Bits 2 to 0—Clock Select 2 to 0 (CSK2 to CSK0): These bits select whether the clock input to 8TCNT is an internal or external clock.

Three internal clocks can be selected, all divided from the system clock (ϕ): $\phi/8$, $\phi/64$, and $\phi/8192$. The rising edge of the selected internal clock triggers the count.

When use of an external clock is selected, three types of count can be selected: at the rising edge, the falling edge, and both rising and falling edges.

Some functions differ between channels 0 and 2 and channels 1 and 3.

Bit 2 CKS2	Bit 1 CKS1	Bit 0 CKS0	Description	
0	0	0	Clock input disabled (Initial value)	
		1	Internal clock, counted on rising edge of $\phi/8$	
	1	0	Internal clock, counted on rising edge of $\phi/64$	
		1	Internal clock, counted on rising edge of $\phi/8192$	
1	0	0	Channel 0: Count on 8TCNT1 overflow signal* ¹ Channel 1: Count on 8TCNT0 compare match A* ¹ Channel 2: Count on 8TCNT3 overflow signal* ² Channel 3: Count on 8TCNT2 compare match A* ²	
		1	External clock, counted on falling edge	
		1	0	External clock, counted on rising edge
			1	External clock, counted on both rising and falling edges

- Notes: 1. If the clock input of channel 0 is the 8TCNT1 overflow signal and that of channel 1 is the 8TCNT0 compare match signal, no incrementing clock is generated. Do not use this setting.
2. If the clock input of channel 2 is the 8TCNT3 overflow signal and that of channel 3 is the 8TCNT2 compare match signal, no incrementing clock is generated. Do not use this setting.

10.2.5 Timer Control/Status Registers (8TCSR)

8TCSR0

Bit	7	6	5	4	3	2	1	0
	CMFB	CMFA	OVF	ADTE	OIS3	OIS2	OS1	OS0
Initial value	0	0	0	0	0	0	0	0
Read/Write	R/(W)*	R/(W)*	R/(W)*	R/W	R/W	R/W	R/W	R/W

8TCSR2

Bit	7	6	5	4	3	2	1	0
	CMFB	CMFA	OVF	—	OIS3	OIS2	OS1	OS0
Initial value	0	0	0	1	0	0	0	0
Read/Write	R/(W)*	R/(W)*	R/(W)*	—	R/W	R/W	R/W	R/W

8TCSR1, 8TCSR3

Bit	7	6	5	4	3	2	1	0
	CMFB	CMFA	OVF	ICE	OIS3	OIS2	OS1	OS0
Initial value	0	0	0	0	0	0	0	0
Read/Write	R/(W)*	R/(W)*	R/(W)*	R/W	R/W	R/W	R/W	R/W

Note: * Only 0 can be written to bits 7 to 5, to clear these flags.

The timer control/status registers (8TCSR) are 8-bit registers that indicate compare match/input capture and timer overflow statuses, and control compare match output/input capture edge selection.

Each 8TCSR is initialized to H'00 by a reset and in standby mode.

Bit 7—Compare Match/Input Capture Flag B (CMFB): Status flag that indicates the occurrence of a TCORB compare match or input capture.

Bit 7

CMFB	Description
0	[Clearing condition] (Initial value) Read CMFB when CMFB = 1, then write 0 in CMFB
1	[Setting conditions] <ul style="list-style-type: none"> • 8TCNT = TCORB • The 8TCNT value is transferred to TCORB by an input capture signal when TCORB functions as an input capture register

Bit 6—Compare Match Flag A (CMFA): Status flag that indicates the occurrence of a TCORA compare match or input capture.

Bit 6 CMFA	Description	
0	Clearing condition Read CMFA when CMFA = 1, then write 0 in CMFA	(Initial value)
1	Setting condition 8TCNT = TCORA	

Bit 5—Timer Overflow Flag (OVF): Status flag that indicates that the 8TCNT has overflowed (H'FF → H'00).

Bit 5 OVF	Description	
0	Clearing condition Read OVF when OVF = 1, then write 0 in OVF	(Initial value)
1	Setting condition 8TCNT overflows from H'FF to H'00	

Bit 4—A/D Trigger Enable (ADTE) (8TCSR0): In combination with TRGE in the A/D control register (ADCR), enables or disables A/D converter start requests by compare match A or an external trigger. Bit 4 of 8TCSR2 is reserved, but can be read and written.

TRGE*	Bit 4 ADTE	Description
0	0	A/D converter start requests by compare match A or an external trigger pin ($\overline{\text{ADTRG}}$) input are disabled (Initial value)
	1	A/D converter start requests by compare match A or an external trigger pin ($\overline{\text{ADTRG}}$) input are disabled
1	0	A/D converter start requests by an external trigger pin ($\overline{\text{ADTRG}}$) are enabled, and A/D converter start requests by compare match A are disabled
	1	A/D converter start requests by compare match A are enabled, and A/D converter start requests by an external trigger pin ($\overline{\text{ADTRG}}$) are disabled

Note: * TRGE is bit 7 of the A/D control register (ADCR).

Bit 4—Input Capture Enable (ICE) (8TCSR1, 8TCSR3): Selects the function of TCORB.

Bit 4

ICE	Description
0	TCORB is a compare match register (Initial value)
1	TCORB is an input capture register

Bits 3 and 2—Output/Input Capture Edge Select B3 and B2 (OIS3, OIS2): In combination with the ICE bit in 8TCSR1 (8TCSR3), these bits select the compare match B output level or the input capture input detected edge.

The function of TCORB1 (TCORB3) depends on the setting of bit 4 of 8TCSR1 (8TCSR3). TCORB0 and TCORB2 function as compare match registers regardless of the setting of bit 4 of 8TCSR1 (8TCSR3).

ICE Bit in

8TCSR1 (8TCSR3)	Bit 3 OIS3	Bit 2 OIS2	Description
0	0	0	No change when compare match B occurs (Initial value)
		1	0 is output when compare match B occurs
	1	0	1 is output when compare match B occurs
		1	Output is inverted when compare match B occurs (toggle output)
1	0	0	TCORB input capture on rising edge
		1	TCORB input capture on falling edge
	1	0	TCORB input capture on both rising and falling edges
		1	

- When the compare match register function is used, the timer output priority order is: toggle output > 1 output > 0 output.
- If compare match A and B occur simultaneously, the output changes in accordance with the higher-priority compare match.
- When bits OIS3, OIS2, OS1, and OS0 are all cleared to 0, timer output is disabled.

Bits 1 and 0—Output Select A1 and A0 (OS1, OS0): These bits select the compare match A output level.

Bit 1 OS1	Bit 0 OS0	Description
0	0	No change when compare match A occurs (Initial value)
	1	0 is output when compare match A occurs
1	0	1 is output when compare match A occurs
	1	Output is inverted when compare match A occurs (toggle output)

- When the compare match register function is used, the timer output priority order is: toggle output > 1 output > 0 output.
- If compare match A and B occur simultaneously, the output changes in accordance with the higher-priority compare match.
- When bits OIS3, OIS2, OS1, and OS0 are all cleared to 0, timer output is disabled.

10.3 CPU Interface

10.3.1 8-Bit Registers

8TCNT, TCORA, TCORB, 8TCR, and 8TCSR are 8-bit registers. These registers are connected to the CPU by an internal 16-bit data bus and can be read and written a word at a time or a byte at a time.

Figures 10.2 and 10.3 show the operation in word read and write accesses to 8TCNT.

Figures 10.4 to 10.7 show the operation in byte read and write accesses to 8TCNT0 and 8TCNT1.

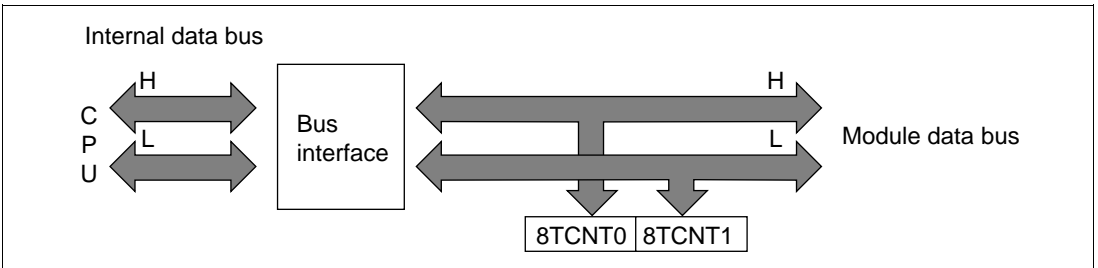

Figure 10.2 8TCNT Access Operation (CPU Writes to 8TCNT, Word)

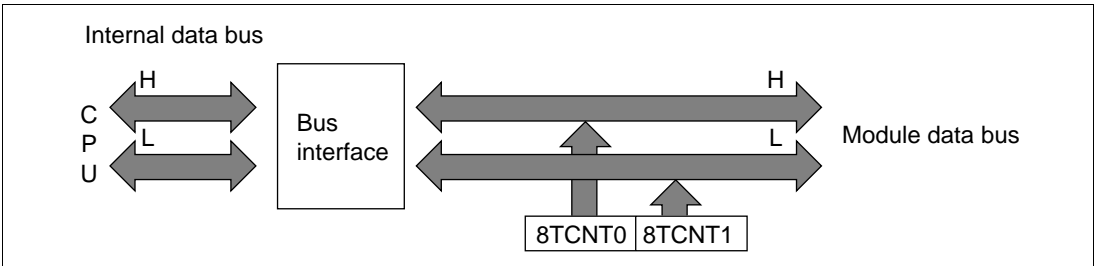

Figure 10.3 8TCNT Access Operation (CPU Reads 8TCNT, Word)

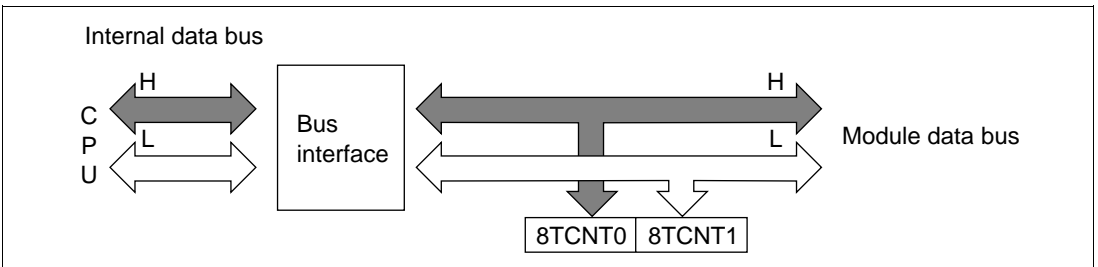

Figure 10.4 8TCNTH Access Operation (CPU Writes to 8TCNTH, Upper Byte)

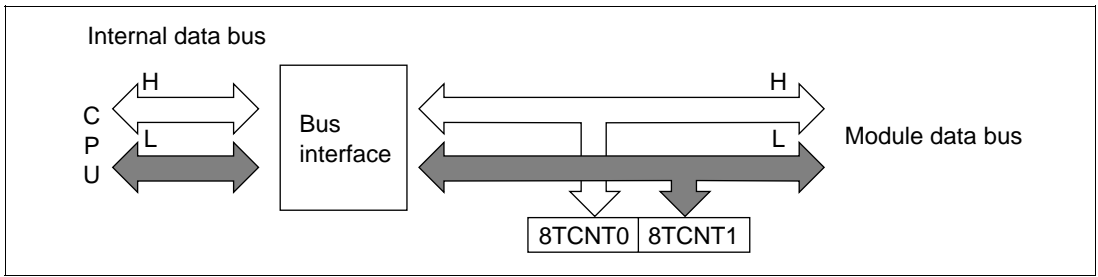

Figure 10.5 8TCNT1 Access Operation (CPU Writes to 8TCNT1, Lower Byte)

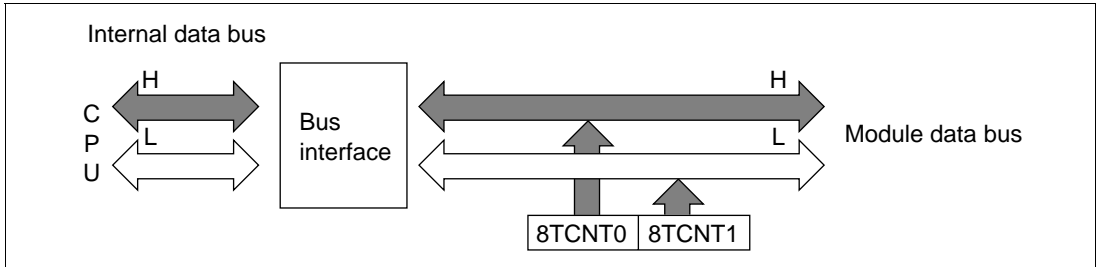

Figure 10.6 8TCNT0 Access Operation (CPU Reads 8TCNT0, Upper Byte)

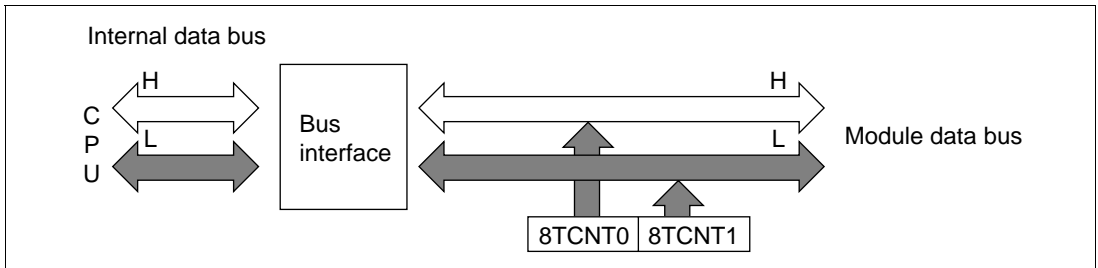

Figure 10.7 8TCNT1 Access Operation (CPU Reads 8TCNT1, Lower Byte)

10.4 Operation

10.4.1 8TCNT Count Timing

8TCNT is incremented by input clock pulses (either internal or external).

Internal Clock: Three different internal clock signals ($\phi/8$, $\phi/64$, or $\phi/8192$) divided from the system clock (ϕ) can be selected by setting bits CKS2 to CKS0 in 8TCR. Figure 10.8 shows the count timing.

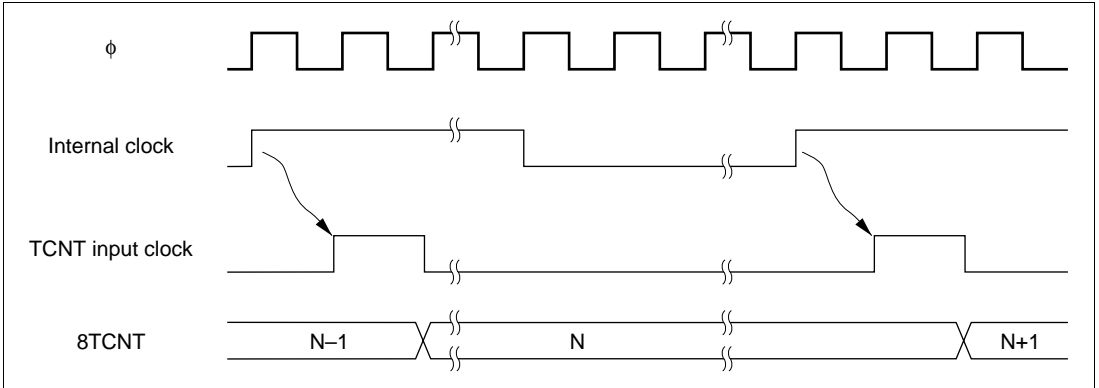

Figure 10.8 Count Timing for Internal Clock Input

Note: Even when the same internal clock is selected for both the 16- and 8-bit timers, they do not operate in the same manner because the count-up edge differs.

External Clock: Three incrementation methods can be selected by setting bits CKS2 to CKS0 in 8TCR: on the rising edge, the falling edge, and both rising and falling edges.

The pulse width of the external clock signal must be at least 1.5 serial clocks when a single edge is selected, and at least 2.5 system clocks when both edges are selected. Shorter pulses will not be counted correctly.

Figure 10.9 shows the timing for incrementation on both edges of the external clock signal.

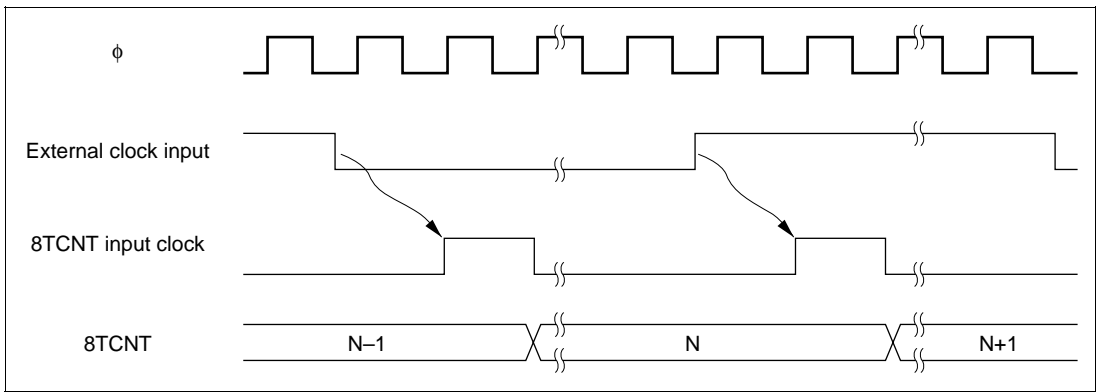

Figure 10.9 Count Timing for External Clock Input (When Detecting the Both Edges)

10.4.2 Compare Match Timing

Timer Output Timing: When compare match A or B occurs, the timer output is as specified by the OIS3, OIS2, OS1, and OS0 bits in 8TCSR (unchanged, 0 output, 1 output, or toggle output).

Figure 10.10 shows the timing when the output is set to toggle on compare match A.

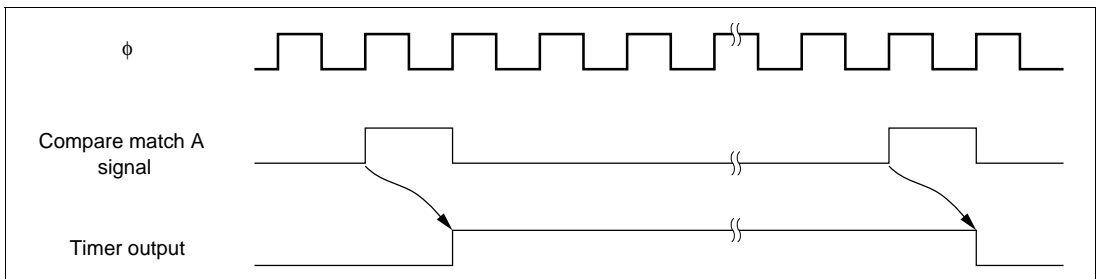

Figure 10.10 Timing of Timer Output

Clear by Compare Match: Depending on the setting of the CCLR1 and CCLR0 bits in 8TCR, 8TCNT can be cleared when compare match A or B occurs, Figure 10.11 shows the timing of this operation.

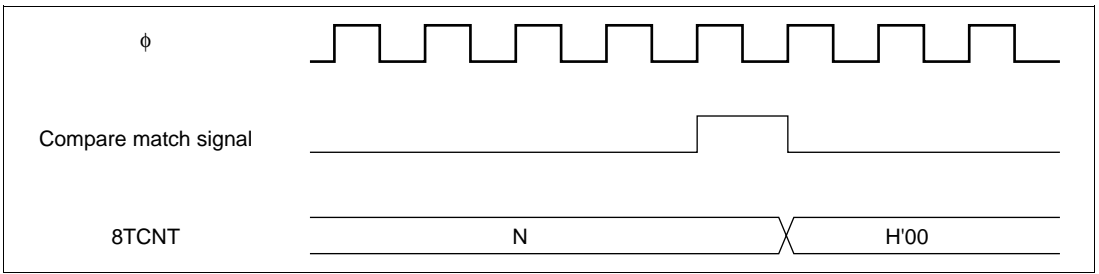

Figure 10.11 Timing of Clear by Compare Match

Clear by Input Capture: Depending on the setting of the CCLR1 and CCLR0 bits in 8TCR, 8TCNT can be cleared when input capture B occurs. Figure 10.12 shows the timing of this operation.

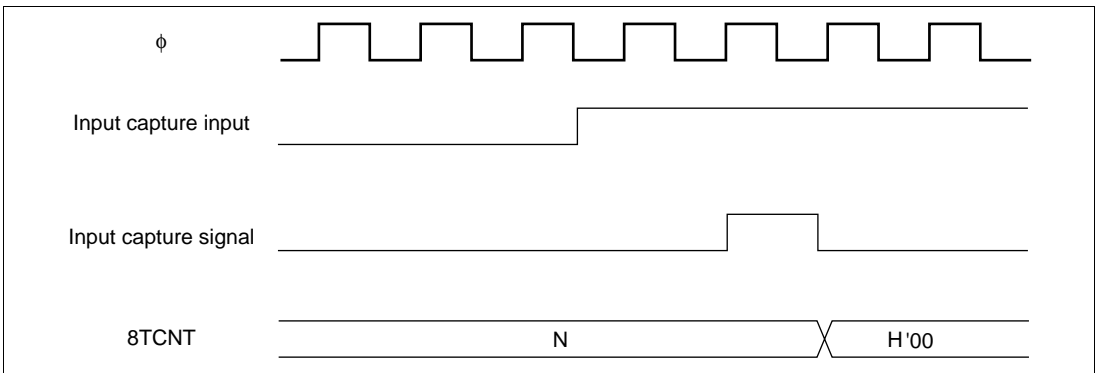

Figure 10.12 Timing of Clear by Input Capture

10.4.3 Input Capture Signal Timing

Input capture on the rising edge, falling edge, or both edges can be selected by settings in 8TCSR.

Figure 10.13 shows the timing when the rising edge is selected.

The pulse width of the input capture input signal must be at least 1.5 system clocks when a single edge is selected, and at least 2.5 system clocks when both edges are selected.

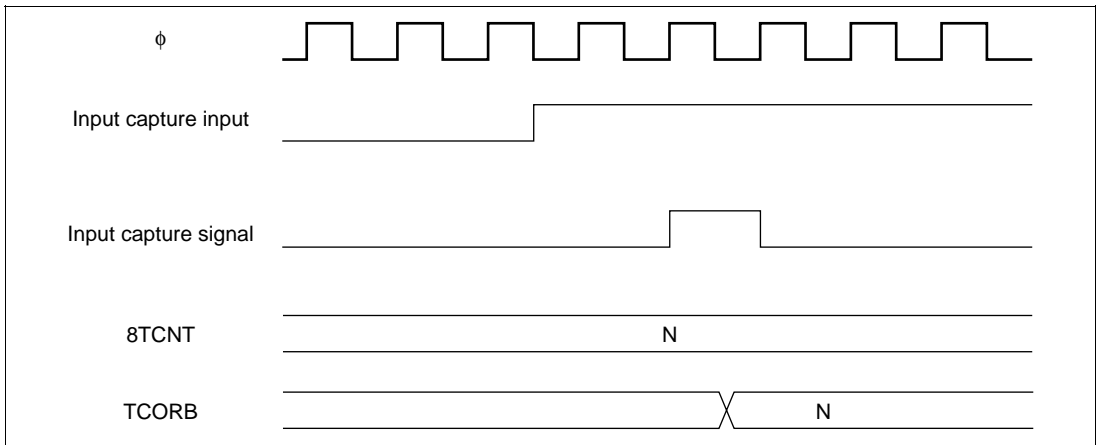

Figure 10.13 Timing of Input Capture Input Signal

10.4.4 Timing of Status Flag Setting

Timing of CMFA/CMFB Flag Setting when Compare Match Occurs: CMFA and CMFB in 8TCSR are set to 1 by the compare match signal output when the TCOR and 8TCNT values match. The compare match signal is generated in the last state of the match (when the matched 8TCNT count value is updated). Therefore, after the 8TCNT and TCOR values match, the compare match signal is not generated until an incrementing clock pulse is generated. Figure 10.14 shows the timing in this case.

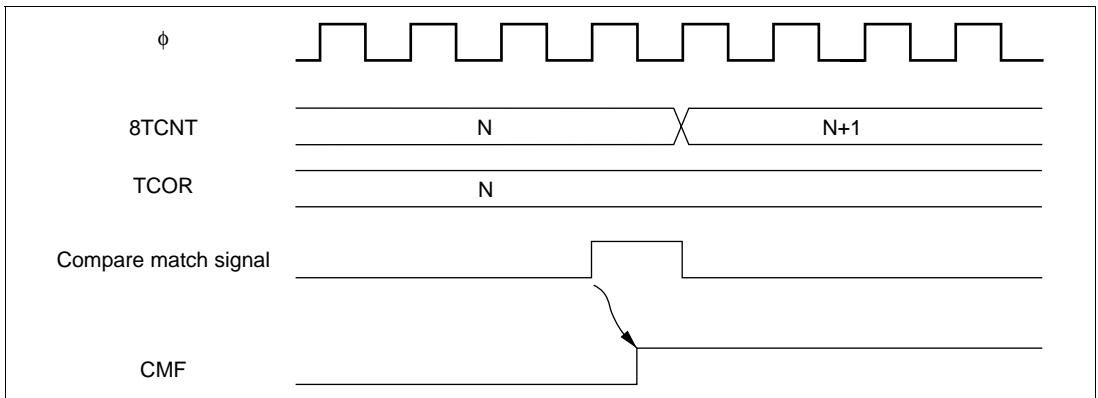

Figure 10.14 CMF Flag Setting Timing when Compare Match Occurs

Timing of CMFB Flag Setting when Input Capture Occurs: On generation of an input capture signal, the CMFB flag is set to 1 and at the same time the 8TCNT value is transferred to TCORB. Figure 10.15 shows the timing in this case.

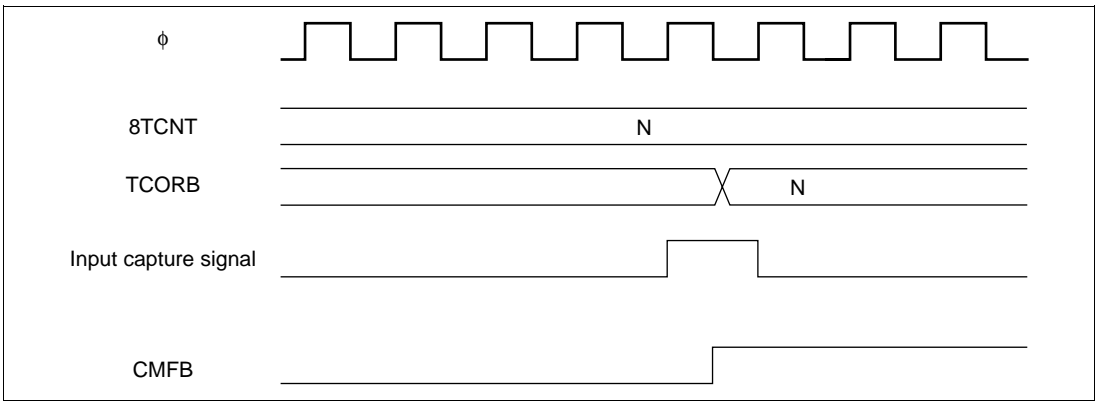

Figure 10.15 CMFB Flag Setting Timing when Input Capture Occurs

Timing of Overflow Flag (OVF) Setting: The OVF flag in 8TCSR is set to 1 by the overflow signal generated when 8TCNT overflows (from H'FF to H'00). Figure 10.16 shows the timing in this case.

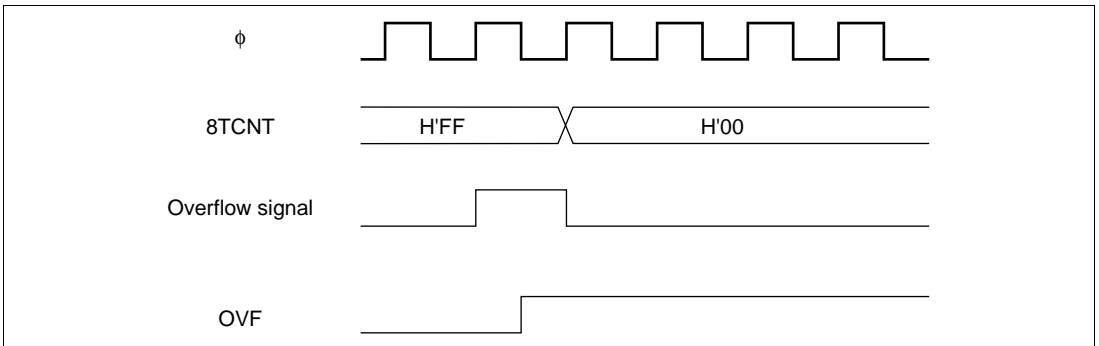

Figure 10.16 Timing of OVF Setting

10.4.5 Operation with Cascaded Connection

If bits CKS2 to CKS0 are set to (100) in either 8TCR0 or 8TCR1, the 8-bit timers of channels 0 and 1 are cascaded. With this configuration, the two timers can be used as a single 16-bit timer (16-bit count mode), or channel 0 8-bit timer compare matches can be counted in channel 1 (compare match count mode). In this case, the timer operates as below. Similarly, if bits CKS2 to CKS0 are set to (100) in either 8TCR2 or 8TCR3, the 8-bit timers of channels 0 and 1 are cascaded. With this configuration, the two timers can be used as a single 16-bit timer (16-bit count mode), or channel 2 8-bit timer compare matches can be counted in channel 3 (compare match count mode). Timer operation in these cases is described below.

16-Bit Count Mode

- Channels 0 and 1:

When bits CKS2 to CKS0 are set to (100) in 8TCR0, the timer functions as a single 16-bit timer with channel 0 occupying the upper 8 bits and channel 1 occupying the lower 8 bits.

— Setting when Compare Match Occurs

- The CMF flag is set to 1 in 8TCR0 when a 16-bit compare match occurs.
- The CMF flag is set to 1 in 8TCR1 when a lower 8-bit compare match occurs.
- TMO₀ pin output control by bits OIS3, OIS2, OS1, and OS0 in 8TCSR0 is in accordance with the 16-bit compare match conditions.
- TMIO₁ pin output control by bits OIS3, OIS2, OS1, and OS0 in 8TCSR1 is in accordance with the lower 8-bit compare match conditions.

— Setting when Input Capture Occurs

- The CMFB flag is set to 1 in 8TCR0 and 8TCR1 when the ICE bit is 1 in 8TCSR1 and input capture occurs.
- TMIO₁ pin input capture input signal edge detection is selected by bits OIS3 and OIS2 in 8TCSR0.

— Counter Clear Specification

- If counter clear on compare match or input capture has been selected by the CCLR1 and CCLR0 bits in 8TCR0, the 16-bit counter (both 8TCNT0 and 8TCNT1) is cleared.
- The settings of the CCLR1 and CCLR0 bits in 8TCR1 are ignored. The lower 8 bits cannot be cleared independently.

— OVF Flag Operation

- The OVF flag is set to 1 in 8TCSR0 when the 16-bit counter (8TCNT0 and 8TCNT1) overflows (from H'FFFF to H'0000).
- The OVF flag is set to 1 in 8TCSR1 when the 8-bit counter (8TCNT1) overflows (from H'FF to H'00).

- Channels 2 and 3:

When bits CKS2 to CKS0 are set to (100) in 8TCR2, the timer functions as a single 16-bit timer with channel 2 occupying the upper 8 bits and channel 3 occupying the lower 8 bits.

— Setting when Compare Match Occurs

- The CMF flag is set to 1 in 8TCR2 when a 16-bit compare match occurs.
- The CMF flag is set to 1 in 8TCR3 when a lower 8-bit compare match occurs.
- TMO₂ pin output control by bits OIS3, OIS2, OS1, and OS0 in 8TCSR2 is in accordance with the 16-bit compare match conditions.
- TMIO₃ pin output control by bits OIS3, OIS2, OS1, and OS0 in 8TCSR3 is in accordance with the lower 8-bit compare match conditions.

- Setting when Input Capture Occurs
 - The CMFB flag is set to 1 in 8TCR2 and 8TCR3 when the ICE bit is 1 in 8TCSR3 and input capture occurs.
 - TMIO₃ pin input capture input signal edge detection is selected by bits OIS3 and OIS2 in 8TCSR2.
- Counter Clear Specification
 - If counter clear on compare match has been selected by the CCLR1 and CCLR0 bits in 8TCR2, the 16-bit counter (both 8TCNT2 and 8TCNT3) is cleared.
 - The settings of the CCLR1 and CCLR0 bits in 8TCR3 are ignored. The lower 8 bits cannot be cleared independently.
- OVF Flag Operation
 - The OVF flag is set to 1 in 8TCSR2 when the 16-bit counter (8TCNT2 and 8TCNT3) overflows (from H'FFFF to H'0000).
 - The OVF flag is set to 1 in 8TCSR3 when the 16-bit counter (8TCNT3) overflows (from H'FF to H'00).

Compare Match Count Mode

- Channels 0 and 1:

When bits CKS2 to CKS0 are set to (100) in 8TCR1, 8TCNT1 counts channel 0 compare match A events.

Channels 0 and 1 are controlled independently. CMF flag setting, interrupt generation, TMO pin output, counter clearing, and so on, is in accordance with the settings for each channel.
- Channels 2 and 3:

When bits CKS2 to CKS0 are set to (100) in 8TCR3, 8TCNT3 counts channel 2 compare match A events.

Channels 2 and 3 are controlled independently. CMF flag setting, interrupt generation, TMO pin output, counter clearing, and so on, is in accordance with the settings for each channel.

Caution

Do not set 16-bit count mode and compare match count mode simultaneously within the same group, as the 8TCNT input clock will not be generated and the counters will not operate.

10.4.6 Input Capture Setting

The 8TCNT value can be transferred to TCORB on detection of an input edge on the input capture/output compare pin (TMIO₁ or TMIO₃). Rising edge, falling edge, or both edge detection can be selected. In 16-bit count mode, 16-bit input capture can be used.

Setting Input Capture Operation in 8-Bit Timer Mode (Normal Operation)

- Channel 1:
 - Set TCORB1 as an 8-bit input capture register with the ICE bit in 8TCSR1.
 - Select rising edge, falling edge, or both edges as the input edge(s) for the input capture signal (TMIO₁) with bits OIS3 and OIS2 in 8TCSR1.
 - Select the input clock with bits CKS2 to CKS0 in 8TCR1, and start the 8TCNT count.
- Channel 3:
 - Set TCORB3 as an 8-bit input capture register with the ICE bit in 8TCSR3.
 - Select rising edge, falling edge, or both edges as the input edge(s) for the input capture signal (TMIO₃) with bits OIS3 and OIS2 in 8TCSR3.
 - Select the input clock with bits CKS2 to CKS0 in 8TCR3, and start the 8TCNT count.

Setting Input Capture Operation in 16-Bit Count Mode

- Channels 0 and 1:
 - In 16-bit count mode, TCORB0 and TCORB1 function as a 16-bit input capture register when the ICE bit is set to 1 in 8TCSR1.
 - Select rising edge, falling edge, or both edges as the input edge(s) for the input capture signal (TMIO₁) with bits OIS3 and OIS2 in 8TCSR0. (In 16-bit count mode, the settings of bits OIS3 and OIS2 in 8TCSR1 are ignored.)
 - Select the input clock with bits CKS2 to CKS0 in 8TCR1, and start the 8TCNT count.
- Channels 2 and 3:
 - In 16-bit count mode, TCORB2 and TCORB3 function as a 16-bit input capture register when the ICE bit is set to 1 in 8TCSR3.
 - Select rising edge, falling edge, or both edges as the input edge(s) for the input capture signal (TMIO₃) with bits OIS3 and OIS2 in 8TCSR2. (In 16-bit count mode, the settings of bits OIS3 and OIS2 in 8TCSR3 are ignored.)
 - Select the input clock with bits CKS2 to CKS0 in 8TCR3, and start the 8TCNT count.

10.5 Interrupt

10.5.1 Interrupt Source

The 8-bit timer unit can generate three types of interrupt: compare match A and B (CMIA and CMIB) and overflow (OVI). Table 10.3 shows the interrupt sources and their priority order. Each interrupt source is enabled or disabled by the corresponding interrupt enable bit in 8TCR. A separate interrupt request signal is sent to the interrupt controller by each interrupt source.

Table 10.3 Types of 8-Bit Timer Interrupt Sources and Priority Order

Interrupt Source	Description	Priority
CMIA	Interrupt by CMFA	High
CMIB	Interrupt by CMFB	↑
TOVI	Interrupt by OVF	Low

For compare match interrupts CMIA1/CMIB1 and CMIA3/CMIB3 and the overflow interrupts (TOVI0/TOVI1 and TOVI2/TOVI3), one vector is shared by two interrupts.

Table 10.4 lists the interrupt sources.

Table 10.4 8-Bit Timer Interrupt Sources

Channel	Interrupt Source	Description
0	CMIA0	TCORA0 compare match
	CMIB0	TCORB0 compare match/input capture
1	CMIA1/CMIB1	TCORA1 compare match, or TCORB1 compare match/input capture
0, 1	TOVI0/TOVI1	Counter 0 or counter 1 overflow
2	CMIA2	TCORA2 compare match
	CMIB2	TCORB2 compare match/input capture
3	CMIA3/CMIB3	TCORA3 compare match, or TCORB3 compare match/input capture
2, 3	TOVI2/TOVI3	Counter 2 or counter 3 overflow

10.5.2 A/D Converter Activation

The A/D converter can only be activated by channel 0 compare match A.

When the CMFA flag in 8TCSR0 is set to 1 and the ADTE bit is also set to 1, activation of the A/D converter will be requested on generation of channel 0 compare match A. If the TRGE bit in ADCR is set to 1 at this time, the A/D converter will be activated. When ADTE bit in 8TCSR0 is set to 1, the A/D converter external trigger pin ($\overline{\text{ADTRG}}$) input is disabled.

10.6 8-Bit Timer Application Example

Figure 10.17 shows how the 8-bit timer module can be used to output pulses with any desired duty cycle. The settings for this example are as follows:

- Clear the CCLR1 bit to 0 and set the CCLR0 bit to 1 in 8TCR so that 8TCNT is cleared by a TCORA compare match.
- Set bits OIS3, OIS2, OS1, and OS0 to (0110) in 8TCSR so that 1 is output on a TCORA compare match and 0 is output on a TCORB compare match.

The above settings enable a waveform with the cycle determined by TCORA and the pulse width detected by TCORB to be output without software intervention.

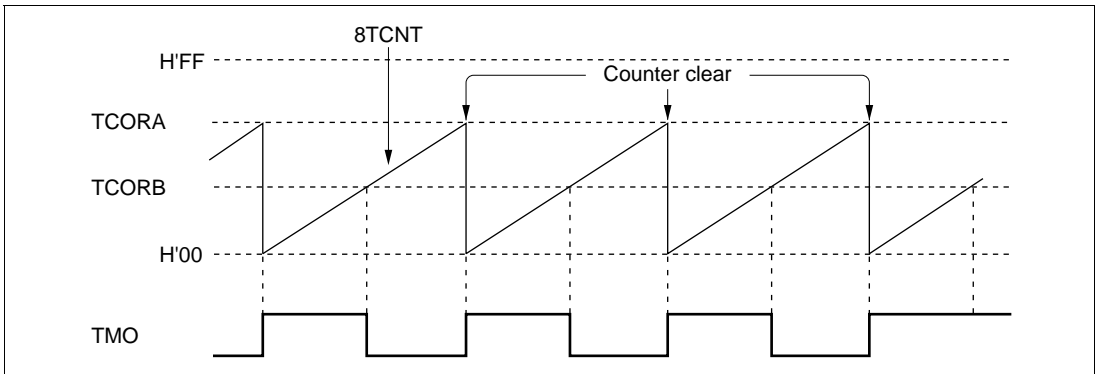

Figure 10.17 Example of Pulse Output

10.7 Usage Notes

Note that the following kinds of contention can occur in 8-bit timer operation.

10.7.1 Contention between 8TCNT Write and Clear

If a timer counter clear signal occurs in the T_3 state of a 8TCNT write cycle, clearing of the counter takes priority and the write is not performed. Figure 10.18 shows the timing in this case.

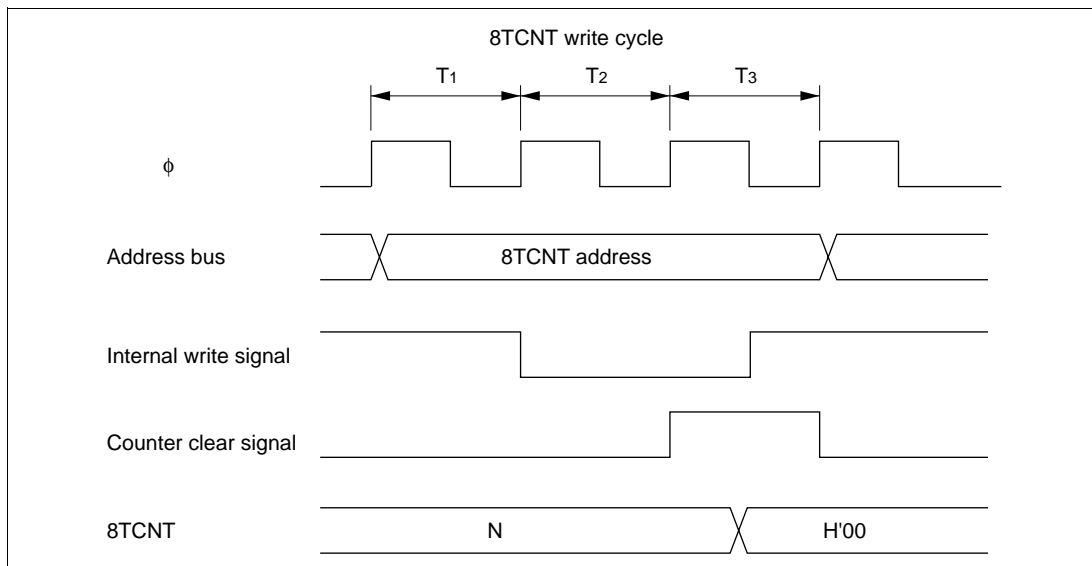

Figure 10.18 Contention between 8TCNT Write and Clear

10.7.2 Contention between 8TCNT Write and Increment

If an increment pulse occurs in the T_3 state of a 8TCNT write cycle, writing takes priority and 8TCNT is not incremented. Figure 10.19 shows the timing in this case.

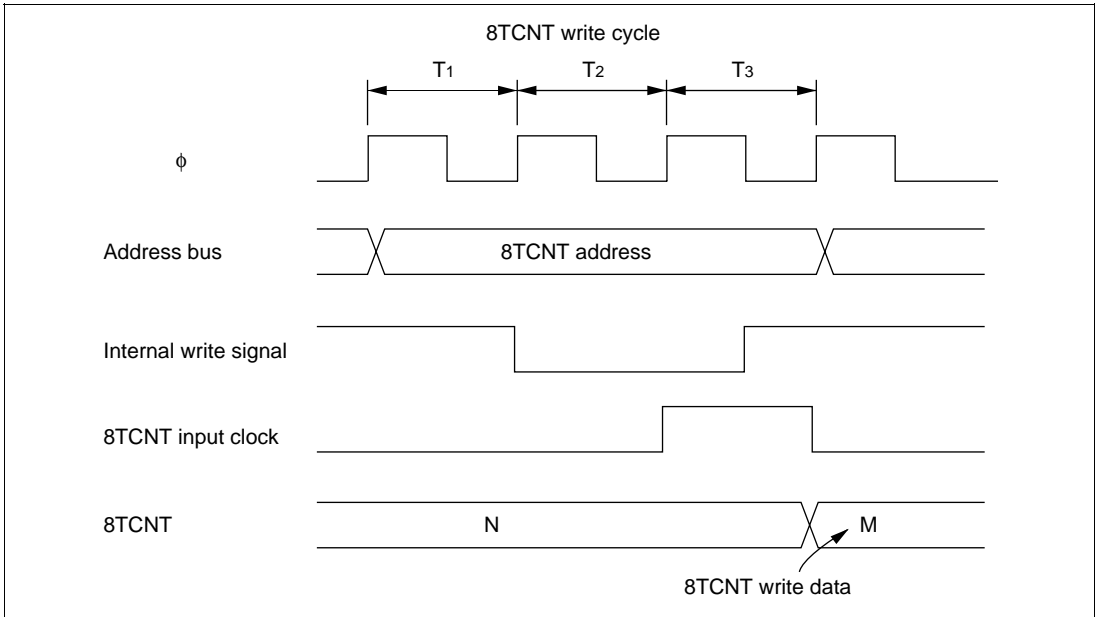

Figure 10.19 Contention between 8TCNT Write and Increment

10.7.3 Contention between TCOR Write and Compare Match

If a compare match occurs in the T_3 state of a TCOR write cycle, writing takes priority and the compare match signal is inhibited. Figure 10.20 shows the timing in this case.

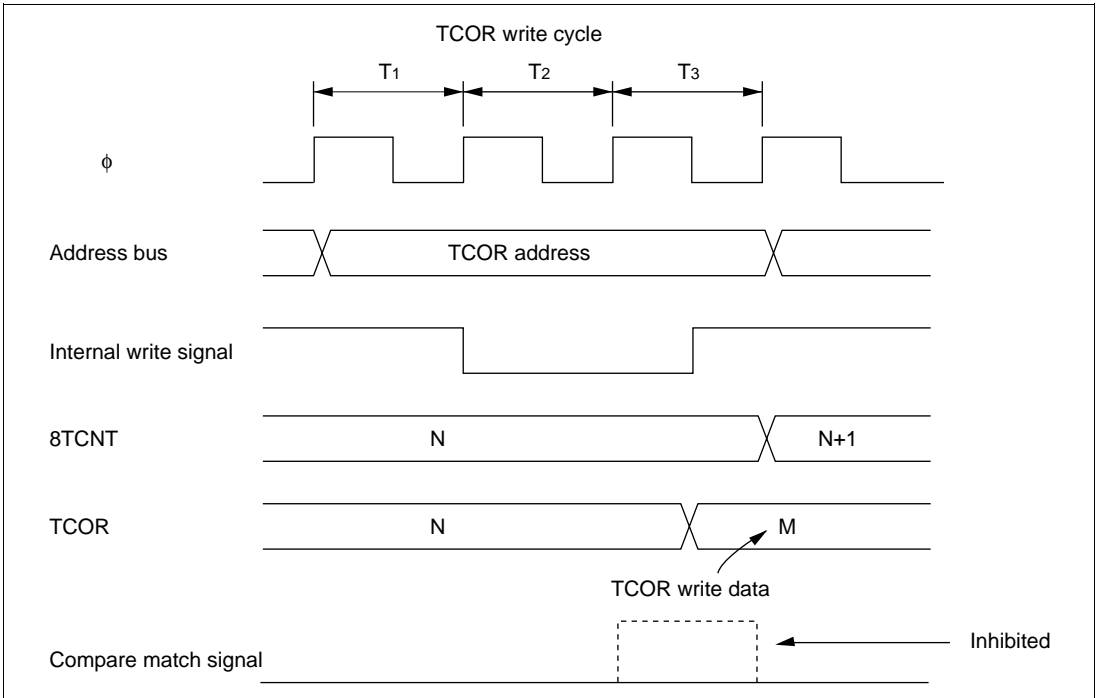

Figure 10.20 Contention between TCOR Write and Compare Match

10.7.4 Contention between TCOR Read and Input Capture

If an input capture signal occurs in the T_3 state of a TCOR read cycle, the value before input capture is read. Figure 10.21 shows the timing in this case.

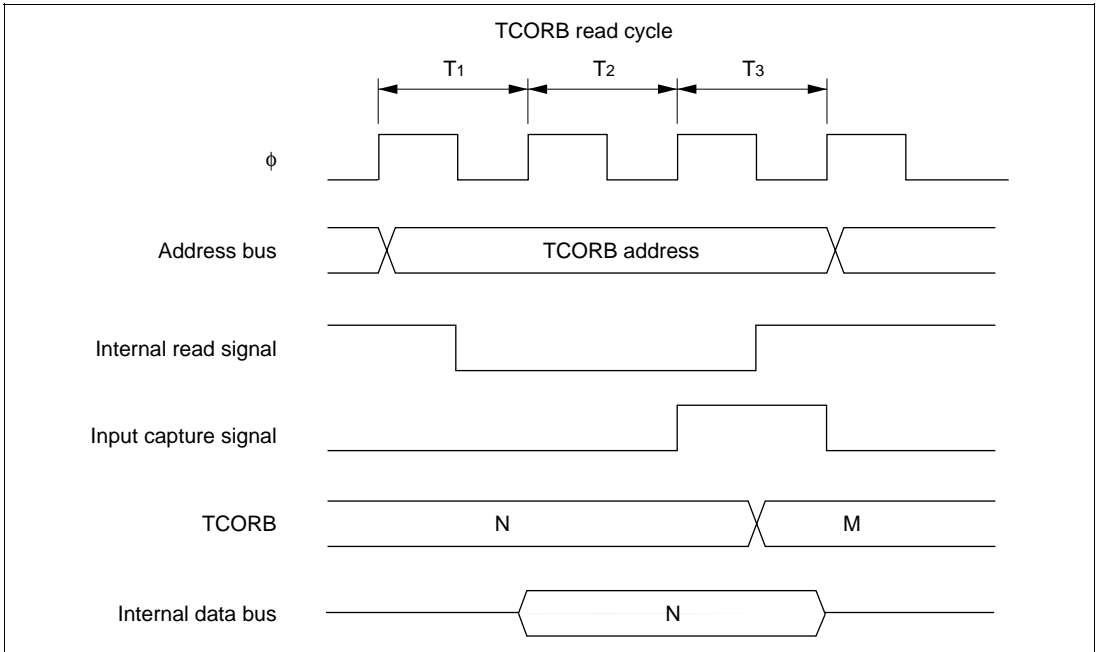

Figure 10.21 Contention between TCOR Read and Input Capture

10.7.5 Contention between Counter Clearing by Input Capture and Counter Increment

If an input capture signal and counter increment signal occur simultaneously, counter clearing by the input capture signal takes priority and the counter is not incremented. The value before the counter is cleared is transferred to TCORB. Figure 10.22 shows the timing in this case.

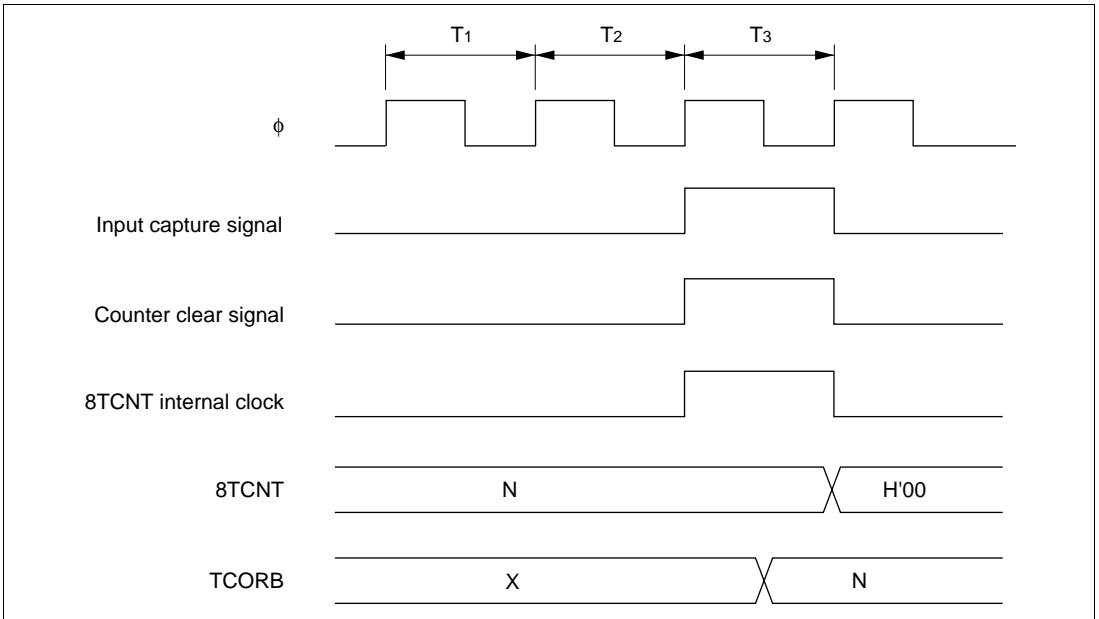

Figure 10.22 Contention between Counter Clearing by Input Capture and Counter Increment

10.7.6 Contention between TCOR Write and Input Capture

If an input capture signal occurs in the T_3 state of a TCOR write cycle, input capture takes priority and the write to TCOR is not performed. Figure 10.23 shows the timing in this case.

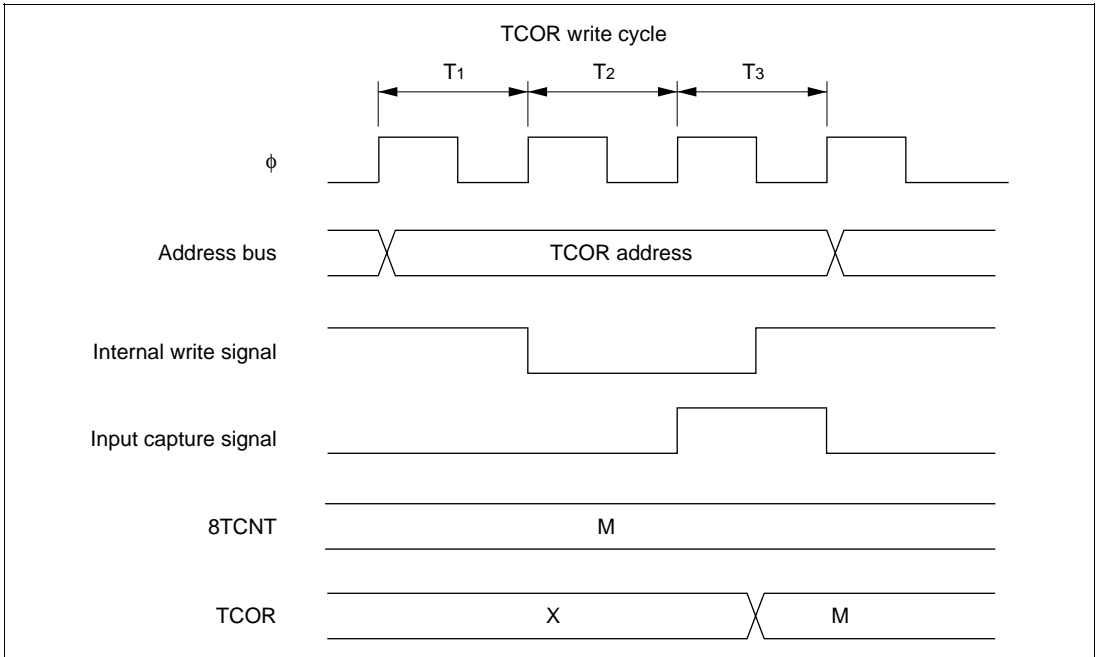

Figure 10.23 Contention between TCOR Write and Input Capture

10.7.7 Contention between 8TCNT Byte Write and Increment in 16-Bit Count Mode (Cascaded Connection)

If an increment pulse occurs in the T_2 or T_3 state of a 8TCNT byte write cycle in 16-bit count mode, writing takes priority and 8TCNT is not incremented. The byte data for which a write was not performed retains its previous value. Figure 10.24 shows the timing when an increment pulse occurs in the T_2 state of a byte write to 8TCNTH.

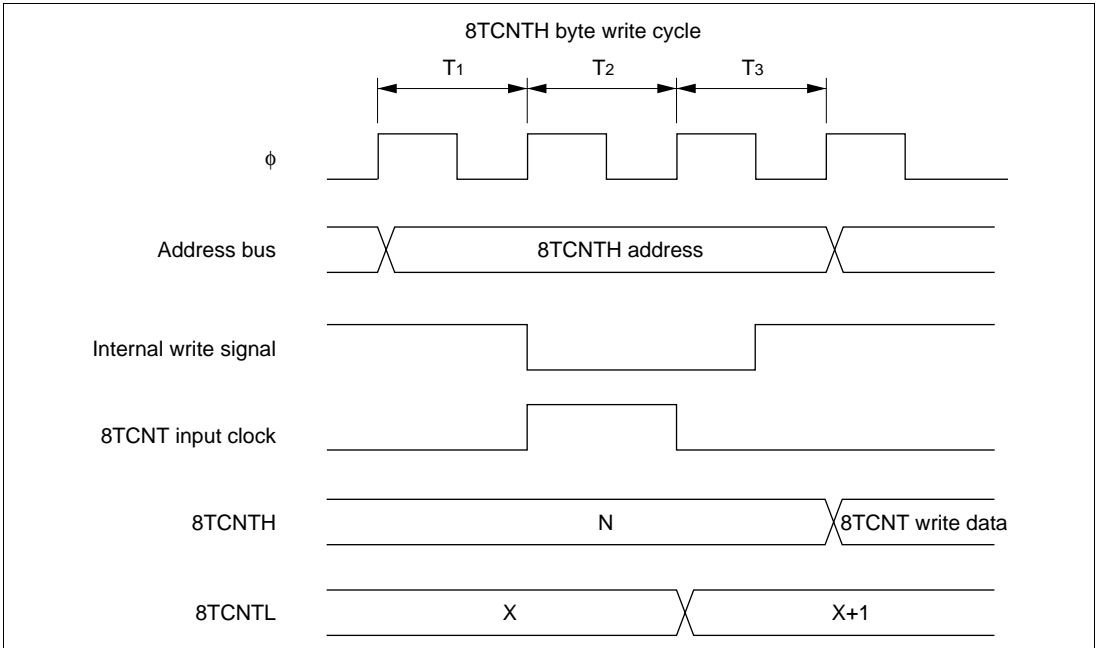

Figure 10.24 Contention between 8TCNT Byte Write and Increment in 16-Bit Count Mode

10.7.8 Contention between Compare Matches A and B

If compare matches A and B occur at the same time, the 8-bit timer operates according to the relative priority of the output states set for compare match A and compare match B, as shown in Table 10.5.

Table 10.5 Timer Output Priority Order

Output Setting	Priority
Toggle output	High
1 output	↑
0 output	
No change	Low

10.7.9 8TCNT Operation at Internal Clock Source Switchover

Switching internal clock sources may cause 8TCNT to increment, depending on the switchover timing. Table 10.6 shows the relation between the time of the switchover (by writing to bits CKS1 and CKS0) and the operation of 8TCNT.

The 8TCNT input clock is generated from the internal clock source by detecting the rising edge of the internal clock. If a switchover is made from a low clock source to a high clock source, as in case No. 3 in Table 10.6, the switchover will be regarded as a falling edge, a 8TCNT clock pulse will be generated, and 8TCNT will be incremented.

8TCNT may also be incremented when switching between internal and external clocks.

Table 10.6 Internal Clock Switchover and 8TCNT Operation

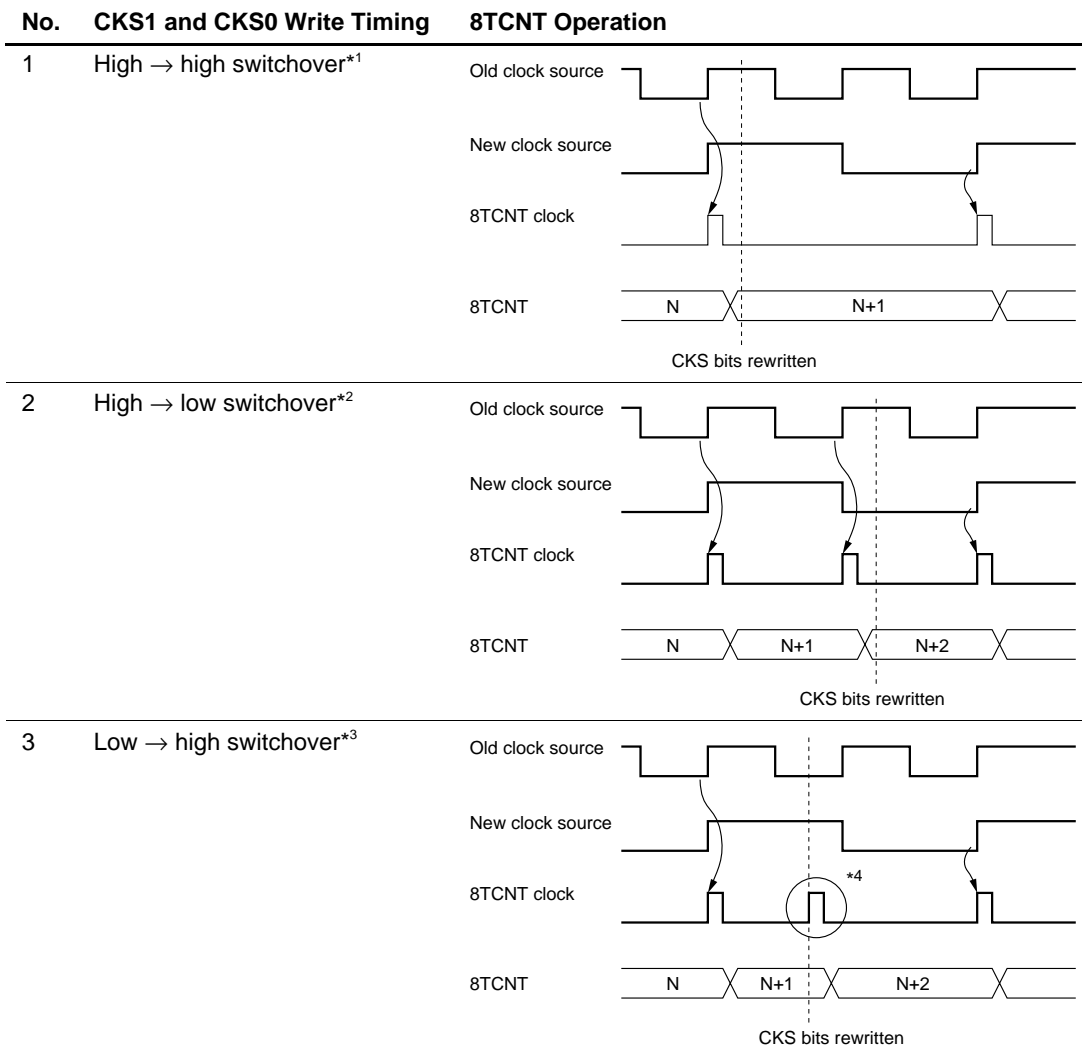

No. CKS1 and CKS0 Write Timing 8TCNT Operation

4 Low → low switchover*4

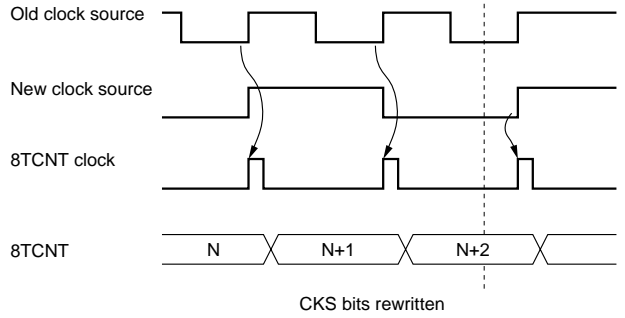

- Notes:
1. Including switchovers from a high clock source to the halted state, and from the halted state to a high clock source.
 2. Including switchover from the halted state to a low clock source.
 3. Including switchover from a low clock source to the halted state.
 4. The switchover is regarded as a rising edge, causing 8TCNT to increment.

Section 11 Programmable Timing Pattern Controller (TPC)

11.1 Overview

The H8/3006 and H8/3007 have a built-in programmable timing pattern controller (TPC) that provides pulse outputs by using the 16-bit timer as a time base. The TPC pulse outputs are divided into 4-bit groups (group 3 to group 0) that can operate simultaneously and independently.

11.1.1 Features

TPC features are listed below.

- 16-bit output data
Maximum 16-bit data can be output. TPC output can be enabled on a bit-by-bit basis.
- Four output groups
Output trigger signals can be selected in 4-bit groups to provide up to four different 4-bit outputs.
- Selectable output trigger signals
Output trigger signals can be selected for each group from the compare match signals of three 16-bit timer channels.
- Non-overlap mode
A non-overlap margin can be provided between pulse outputs.
- Can operate together with the DMA controller (DMAC)
The compare-match signals selected as trigger signals can activate the DMAC for sequential output of data without CPU intervention.

11.1.2 Block Diagram

Figure 11.1 shows a block diagram of the TPC.

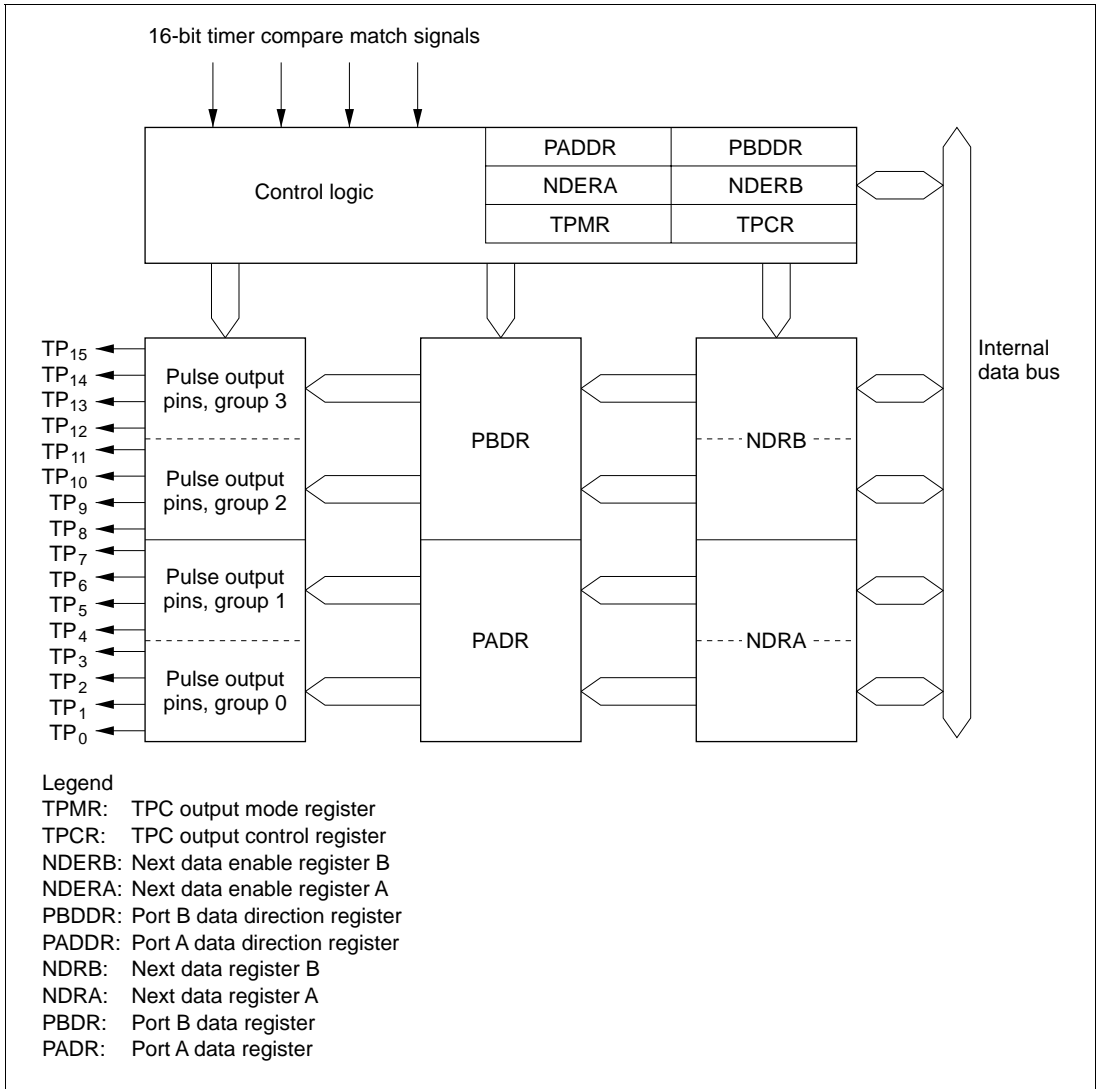

Figure 11.1 TPC Block Diagram

11.1.3 Pin Configuration

Table 11.1 summarizes the TPC output pins.

Table 11.1 TPC Pins

Name	Symbol	I/O	Function
TPC output 0	TP ₀	Output	Group 0 pulse output
TPC output 1	TP ₁	Output	
TPC output 2	TP ₂	Output	
TPC output 3	TP ₃	Output	Group 1 pulse output
TPC output 4	TP ₄	Output	
TPC output 5	TP ₅	Output	
TPC output 6	TP ₆	Output	
TPC output 7	TP ₇	Output	
TPC output 8	TP ₈	Output	Group 2 pulse output
TPC output 9	TP ₉	Output	
TPC output 10	TP ₁₀	Output	
TPC output 11	TP ₁₁	Output	Group 3 pulse output
TPC output 12	TP ₁₂	Output	
TPC output 13	TP ₁₃	Output	
TPC output 14	TP ₁₄	Output	
TPC output 15	TP ₁₅	Output	

11.1.4 Register Configuration

Table 11.2 summarizes the TPC registers.

Table 11.2 TPC Registers

Address* ¹	Name	Abbreviation	R/W	Function
H'EE009	Port A data direction register	PADDR	W	H'00
H'FFFD9	Port A data register	PADR	R/(W)* ²	H'00
H'EE00A	Port B data direction register	PBDDR	W	H'00
H'FFFDA	Port B data register	PBDR	R/(W)* ²	H'00
H'FFFA0	TPC output mode register	TPMR	R/W	H'F0
H'FFFA1	TPC output control register	TPCR	R/W	H'FF
H'FFFA2	Next data enable register B	NDERB	R/W	H'00
H'FFFA3	Next data enable register A	NDERA	R/W	H'00
H'FFFA5/ H'FFFA7* ³	Next data register A	NDRA	R/W	H'00
H'FFFA4/ H'FFFA6* ³	Next data register B	NDRB	R/W	H'00

Notes: 1. Lower 20 bits of the address in advanced mode.

2. Bits used for TPC output cannot be written.

3. The NDRA address is H'FFFA5 when the same output trigger is selected for TPC output groups 0 and 1 by settings in TPCR. When the output triggers are different, the NDRA address is H'FFFA7 for group 0 and H'FFFA5 for group 1. Similarly, the address of NDRB is H'FFFA4 when the same output trigger is selected for TPC output groups 2 and 3 by settings in TPCR. When the output triggers are different, the NDRB address is H'FFFA6 for group 2 and H'FFFA4 for group 3.

11.2 Register Descriptions

11.2.1 Port A Data Direction Register (PADDR)

PADDR is an 8-bit write-only register that selects input or output for each pin in port A.

Bit	7	6	5	4	3	2	1	0
	PA ₇ DDR	PA ₆ DDR	PA ₅ DDR	PA ₄ DDR	PA ₃ DDR	PA ₂ DDR	PA ₁ DDR	PA ₀ DDR
Initial value	0	0	0	0	0	0	0	0
Read/Write	W	W	W	W	W	W	W	W

Port A data direction 7 to 0

These bits select input or output for port A pins

Port A is multiplexed with pins TP₇ to TP₀. Bits corresponding to pins used for TPC output must be set to 1. For further information about PADDR, see section 8.7, Port A.

11.2.2 Port A Data Register (PADR)

PADR is an 8-bit readable/writable register that stores TPC output data for groups 0 and 1, when these TPC output groups are used.

Bit	7	6	5	4	3	2	1	0
	PA ₇	PA ₆	PA ₅	PA ₄	PA ₃	PA ₂	PA ₁	PA ₀
Initial value	0	0	0	0	0	0	0	0
Read/Write	R/(W)*	R/(W)*	R/(W)*	R/(W)*	R/(W)*	R/(W)*	R/(W)*	R/(W)*

Port A data 7 to 0

These bits store output data for TPC output groups 0 and 1

Note: * Bits selected for TPC output by NDERA settings become read-only bits.

For further information about PADR, see section 8.7, Port A.

11.2.3 Port B Data Direction Register (PBDDR)

PBDDR is an 8-bit write-only register that selects input or output for each pin in port B.

Bit	7	6	5	4	3	2	1	0
	PB ₇ DDR	PB ₆ DDR	PB ₅ DDR	PB ₄ DDR	PB ₃ DDR	PB ₂ DDR	PB ₁ DDR	PB ₀ DDR
Initial value	0	0	0	0	0	0	0	0
Read/Write	W	W	W	W	W	W	W	W

Port B data direction 7 to 0

These bits select input or output for port B pins

Port B is multiplexed with pins TP₁₅ to TP₈. Bits corresponding to pins used for TPC output must be set to 1. For further information about PBDDR, see section 8.8, Port B.

11.2.4 Port B Data Register (PBDR)

PBDR is an 8-bit readable/writable register that stores TPC output data for groups 2 and 3, when these TPC output groups are used.

Bit	7	6	5	4	3	2	1	0
	PB ₇	PB ₆	PB ₅	PB ₄	PB ₃	PB ₂	PB ₁	PB ₀
Initial value	0	0	0	0	0	0	0	0
Read/Write	R/(W)*	R/(W)*	R/(W)*	R/(W)*	R/(W)*	R/(W)*	R/(W)*	R/(W)*

Port B data 7 to 0

These bits store output data for TPC output groups 2 and 3

Note: * Bits selected for TPC output by NDERB settings become read-only bits.

For further information about PBDR, see section 8.8, Port B.

11.2.5 Next Data Register A (NDRA)

NDRA is an 8-bit readable/writable register that stores the next output data for TPC output groups 1 and 0 (pins TP₇ to TP₀). During TPC output, when an 16-bit timer compare match event specified in TPCR occurs, NDRA contents are transferred to the corresponding bits in PADR. The address of NDRA differs depending on whether TPC output groups 0 and 1 have the same output trigger or different output triggers.

NDRA is initialized to H'00 by a reset and in hardware standby mode. It is not initialized in software standby mode.

Same Trigger for TPC Output Groups 0 and 1: If TPC output groups 0 and 1 are triggered by the same compare match event, the NDRA address is H'FFFA5. The upper 4 bits belong to group 1 and the lower 4 bits to group 0. Address H'FFFA7 consists entirely of reserved bits that cannot be modified and always read 1.

Address H'FFFA5

Bit	7	6	5	4	3	2	1	0
	NDR7	NDR6	NDR5	NDR4	NDR3	NDR2	NDR1	NDR0
Initial value	0	0	0	0	0	0	0	0
Read/Write	R/W	R/W	R/W	R/W	R/W	R/W	R/W	R/W

Next data 7 to 4	Next data 3 to 0
These bits store the next output data for TPC output group 1	These bits store the next output data for TPC output group 0

Address H'FFFA7

Bit	7	6	5	4	3	2	1	0
	—	—	—	—	—	—	—	—
Initial value	1	1	1	1	1	1	1	1
Read/Write	—	—	—	—	—	—	—	—

Reserved bits

Different Triggers for TPC Output Groups 0 and 1: If TPC output groups 0 and 1 are triggered by different compare match events, the address of the upper 4 bits of NDRA (group 1) is H'FFFA5 and the address of the lower 4 bits (group 0) is H'FFFA7. Bits 3 to 0 of address H'FFFA5 and bits 7 to 4 of address H'FFFA7 are reserved bits that cannot be modified and always read 1.

Address H'FFFA5

Bit	7	6	5	4	3	2	1	0
	NDR7	NDR6	NDR5	NDR4	—	—	—	—
Initial value	0	0	0	0	1	1	1	1
Read/Write	R/W	R/W	R/W	R/W	—	—	—	—

Next data 7 to 4
These bits store the next output data for TPC output group 1
Reserved bits

Address H'FFFA7

Bit	7	6	5	4	3	2	1	0
	—	—	—	—	NDR3	NDR2	NDR1	NDR0
Initial value	1	1	1	1	0	0	0	0
Read/Write	—	—	—	—	R/W	R/W	R/W	R/W

Reserved bits
Next data 3 to 0
These bits store the next output data for TPC output group 0

11.2.6 Next Data Register B (NDRB)

NDRB is an 8-bit readable/writable register that stores the next output data for TPC output groups 3 and 2 (pins TP₁₅ to TP₈). During TPC output, when an 16-bit timer compare match event specified in TPCR occurs, NDRB contents are transferred to the corresponding bits in PBDR. The address of NDRB differs depending on whether TPC output groups 2 and 3 have the same output trigger or different output triggers.

NDRB is initialized to H'00 by a reset and in hardware standby mode. It is not initialized in software standby mode.

Same Trigger for TPC Output Groups 2 and 3: If TPC output groups 2 and 3 are triggered by the same compare match event, the NDRB address is H'FFFA4. The upper 4 bits belong to group 3 and the lower 4 bits to group 2. Address H'FFFA6 consists entirely of reserved bits that cannot be modified and always read 1.

Address H'FFFA4

Bit	7	6	5	4	3	2	1	0
	NDR15	NDR14	NDR13	NDR12	NDR11	NDR10	NDR9	NDR8
Initial value	0	0	0	0	0	0	0	0
Read/Write	R/W	R/W	R/W	R/W	R/W	R/W	R/W	R/W

Next data 15 to 12	Next data 11 to 8
These bits store the next output data for TPC output group 3	These bits store the next output data for TPC output group 2

Address H'FFFA6

Bit	7	6	5	4	3	2	1	0
	—	—	—	—	—	—	—	—
Initial value	1	1	1	1	1	1	1	1
Read/Write	—	—	—	—	—	—	—	—

Reserved bits

Different Triggers for TPC Output Groups 2 and 3: If TPC output groups 2 and 3 are triggered by different compare match events, the address of the upper 4 bits of NDRB (group 3) is H'FFFA4 and the address of the lower 4 bits (group 2) is H'FFFA6. Bits 3 to 0 of address H'FFFA4 and bits 7 to 4 of address H'FFFA6 are reserved bits that cannot be modified and always read 1.

Address H'FFFA4

Bit	7	6	5	4	3	2	1	0
	NDR15	NDR14	NDR13	NDR12	—	—	—	—
Initial value	0	0	0	0	1	1	1	1
Read/Write	R/W	R/W	R/W	R/W	—	—	—	—

Next data 15 to 12
These bits store the next output data for TPC output group 3
Reserved bits

Address H'FFFA6

Bit	7	6	5	4	3	2	1	0
	—	—	—	—	NDR11	NDR10	NDR9	NDR8
Initial value	1	1	1	1	0	0	0	0
Read/Write	—	—	—	—	R/W	R/W	R/W	R/W

Reserved bits
Next data 11 to 8
These bits store the next output data for TPC output group 2

11.2.7 Next Data Enable Register A (NDERA)

NDERA is an 8-bit readable/writable register that enables or disables TPC output groups 1 and 0 (TP₇ to TP₀) on a bit-by-bit basis.

Bit	7	6	5	4	3	2	1	0
	NDER7	NDER6	NDER5	NDER4	NDER3	NDER2	NDER1	NDER0
Initial value	0	0	0	0	0	0	0	0
Read/Write	R/W	R/W	R/W	R/W	R/W	R/W	R/W	R/W

Next data enable 7 to 0

These bits enable or disable
TPC output groups 1 and 0

If a bit is enabled for TPC output by NDERA, then when the 16-bit timer compare match event selected in the TPC output control register (TPCR) occurs, the NDRA value is automatically transferred to the corresponding PADR bit, updating the output value. If TPC output is disabled, the bit value is not transferred from NDRA to PADR and the output value does not change.

NDERA is initialized to H'00 by a reset and in hardware standby mode. It is not initialized in software standby mode.

Bits 7 to 0—Next Data Enable 7 to 0 (NDER7 to NDER0): These bits enable or disable TPC output groups 1 and 0 (TP₇ to TP₀) on a bit-by-bit basis.

Bits 7 to 0

NDER7 to NDER0	Description
0	TPC outputs TP ₇ to TP ₀ are disabled (NDR7 to NDR0 are not transferred to PA ₇ to PA ₀) (Initial value)
1	TPC outputs TP ₇ to TP ₀ are enabled (NDR7 to NDR0 are transferred to PA ₇ to PA ₀)

11.2.8 Next Data Enable Register B (NDERB)

NDERB is an 8-bit readable/writable register that enables or disables TPC output groups 3 and 2 (TP₁₅ to TP₈) on a bit-by-bit basis.

Bit	7	6	5	4	3	2	1	0
	NDER15	NDER14	NDER13	NDER12	NDER11	NDER10	NDER9	NDER8
Initial value	0	0	0	0	0	0	0	0
Read/Write	R/W	R/W	R/W	R/W	R/W	R/W	R/W	R/W

Next data enable 15 to 8

These bits enable or disable
TPC output groups 3 and 2

If a bit is enabled for TPC output by NDERB, then when the 16-bit timer compare match event selected in the TPC output control register (TPCR) occurs, the NDRB value is automatically transferred to the corresponding PBDR bit, updating the output value. If TPC output is disabled, the bit value is not transferred from NDRB to PBDR and the output value does not change.

NDERB is initialized to H'00 by a reset and in hardware standby mode. It is not initialized in software standby mode.

Bits 7 to 0—Next Data Enable 15 to 8 (NDER15 to NDER8): These bits enable or disable TPC output groups 3 and 2 (TP₁₅ to TP₈) on a bit-by-bit basis.

Bits 7 to 0

NDER15 to NDER8

Description

0	TPC outputs TP ₁₅ to TP ₈ are disabled (NDR15 to NDR8 are not transferred to PB ₇ to PB ₀)	(Initial value)
1	TPC outputs TP ₁₅ to TP ₈ are enabled (NDR15 to NDR8 are transferred to PB ₇ to PB ₀)	

11.2.9 TPC Output Control Register (TPCR)

TPCR is an 8-bit readable/writable register that selects output trigger signals for TPC outputs on a group-by-group basis.

Bit	7	6	5	4	3	2	1	0
	G3CMS1	G3CMS0	G2CMS1	G2CMS0	G1CMS1	G1CMS0	G0CMS1	G0CMS0
Initial value	1	1	1	1	1	1	1	1
Read/Write	R/W	R/W	R/W	R/W	R/W	R/W	R/W	R/W

<p>Group 3 compare match select 1 and 0 These bits select the compare match event that triggers TPC output group 3 (TP₁₅ to TP₁₂)</p>	<p>Group 2 compare match select 1 and 0 These bits select the compare match event that triggers TPC output group 2 (TP₁₁ to TP₈)</p>	<p>Group 1 compare match select 1 and 0 These bits select the compare match event that triggers TPC output group 1 (TP₇ to TP₄)</p>	<p>Group 0 compare match select 1 and 0 These bits select the compare match event that triggers TPC output group 0 (TP₃ to TP₀)</p>
--	---	--	--

TPCR is initialized to H'FF by a reset and in hardware standby mode. It is not initialized in software standby mode.

Bits 7 and 6—Group 3 Compare Match Select 1 and 0 (G3CMS1, G3CMS0): These bits select the compare match event that triggers TPC output group 3 (TP₁₅ to TP₁₂).

Bit 7 G3CMS1	Bit 6 G3CMS0	Description
0	0	TPC output group 3 (TP ₁₅ to TP ₁₂) is triggered by compare match in 16-bit timer channel 0
	1	TPC output group 3 (TP ₁₅ to TP ₁₂) is triggered by compare match in 16-bit timer channel 1
1	0	TPC output group 3 (TP ₁₅ to TP ₁₂) is triggered by compare match in 16-bit timer channel 2
	1	TPC output group 3 (TP ₁₅ to TP ₁₂) is triggered by compare match in 16-bit timer channel 2 (Initial value)

Bits 5 and 4—Group 2 Compare Match Select 1 and 0 (G2CMS1, G2CMS0): These bits select the compare match event that triggers TPC output group 2 (TP₁₁ to TP₈).

Bit 5 G2CMS1	Bit 4 G2CMS0	Description
0	0	TPC output group 2 (TP ₁₁ to TP ₈) is triggered by compare match in 16-bit timer channel 0
	1	TPC output group 2 (TP ₁₁ to TP ₈) is triggered by compare match in 16-bit timer channel 1
1	0	TPC output group 2 (TP ₁₁ to TP ₈) is triggered by compare match in 16-bit timer channel 2
	1	TPC output group 2 (TP ₁₁ to TP ₈) is triggered by compare match in 16-bit timer channel 2 (Initial value)

Bits 3 and 2—Group 1 Compare Match Select 1 and 0 (G1CMS1, G1CMS0): These bits select the compare match event that triggers TPC output group 1 (TP₇ to TP₄).

Bit 3 G1CMS1	Bit 2 G1CMS0	Description
0	0	TPC output group 1 (TP ₇ to TP ₄) is triggered by compare match in 16-bit timer channel 0
	1	TPC output group 1 (TP ₇ to TP ₄) is triggered by compare match in 16-bit timer channel 1
1	0	TPC output group 1 (TP ₇ to TP ₄) is triggered by compare match in 16-bit timer channel 2
	1	TPC output group 1 (TP ₇ to TP ₄) is triggered by compare match in 16-bit timer channel 2 (Initial value)

Bits 1 and 0—Group 0 Compare Match Select 1 and 0 (G0CMS1, G0CMS0): These bits select the compare match event that triggers TPC output group 0 (TP₃ to TP₀).

Bit 1 G0CMS1	Bit 0 G0CMS0	Description
0	0	TPC output group 0 (TP ₃ to TP ₀) is triggered by compare match in 16-bit timer channel 0
	1	TPC output group 0 (TP ₃ to TP ₀) is triggered by compare match in 16-bit timer channel 1
1	0	TPC output group 0 (TP ₃ to TP ₀) is triggered by compare match in 16-bit timer channel 2
	1	TPC output group 0 (TP ₃ to TP ₀) is triggered by compare match in 16-bit timer channel 2 (Initial value)

11.2.10 TPC Output Mode Register (TPMR)

TPMR is an 8-bit readable/writable register that selects normal or non-overlapping TPC output for each group.

Bit	7	6	5	4	3	2	1	0
	—	—	—	—	G3NOV	G2NOV	G1NOV	G0NOV
Initial value	1	1	1	1	0	0	0	0
Read/Write	—	—	—	—	R/W	R/W	R/W	R/W

Reserved bits

Group 3 non-overlap _____
 Selects non-overlapping TPC output for group 3 (TP₁₅ to TP₁₂)

Group 2 non-overlap _____
 Selects non-overlapping TPC output for group 2 (TP₁₁ to TP₈)

Group 1 non-overlap _____
 Selects non-overlapping TPC output for group 1 (TP₇ to TP₄)

Group 0 non-overlap _____
 Selects non-overlapping TPC output for group 0 (TP₃ to TP₀)

The output trigger period of a non-overlapping TPC output waveform is set in general register B (GRB) in the 16-bit timer channel selected for output triggering. The non-overlap margin is set in general register A (GRA). The output values change at compare match A and B. For details see section 11.3.4, Non-Overlapping TPC Output.

TPMR is initialized to H'F0 by a reset and in hardware standby mode. It is not initialized in software standby mode.

Bits 7 to 4—Reserved: These bits cannot be modified and are always read as 1.

Bit 3—Group 3 Non-Overlap (G3NOV): Selects normal or non-overlapping TPC output for group 3 (TP₁₅ to TP₁₂).

Bit 3

G3NOV	Description	
0	Normal TPC output in group 3 (output values change at compare match A in the selected 16-bit timer channel)	(Initial value)
1	Non-overlapping TPC output in group 3 (independent 1 and 0 output at compare match A and B in the selected 16-bit timer channel)	

Bit 2—Group 2 Non-Overlap (G2NOV): Selects normal or non-overlapping TPC output for group 2 (TP₁₁ to TP₈).

Bit 2

G2NOV	Description	
0	Normal TPC output in group 2 (output values change at compare match A in the selected 16-bit timer channel)	(Initial value)
1	Non-overlapping TPC output in group 2 (independent 1 and 0 output at compare match A and B in the selected 16-bit timer channel)	

Bit 1—Group 1 Non-Overlap (G1NOV): Selects normal or non-overlapping TPC output for group 1 (TP₇ to TP₄).

Bit 1

G1NOV	Description	
0	Normal TPC output in group 1 (output values change at compare match A in the selected 16-bit timer channel)	(Initial value)
1	Non-overlapping TPC output in group 1 (independent 1 and 0 output at compare match A and B in the selected 16-bit timer channel)	

Bit 0—Group 0 Non-Overlap (G0NOV): Selects normal or non-overlapping TPC output for group 0 (TP₃ to TP₀).

Bit 0

G0NOV	Description	
0	Normal TPC output in group 0 (output values change at compare match A in the selected 16-bit timer channel)	(Initial value)
1	Non-overlapping TPC output in group 0 (independent 1 and 0 output at compare match A and B in the selected 16-bit timer channel)	

11.3 Operation

11.3.1 Overview

When corresponding bits in PADDR or PBDDR and NDERA or NDERB are set to 1, TPC output is enabled. The TPC output initially consists of the corresponding PADDR or PBDDR contents. When a compare-match event selected in TPCR occurs, the corresponding NDRA or NDRB bit contents are transferred to PADDR or PBDDR to update the output values.

Figure 11.2 illustrates the TPC output operation. Table 11.3 summarizes the TPC operating conditions.

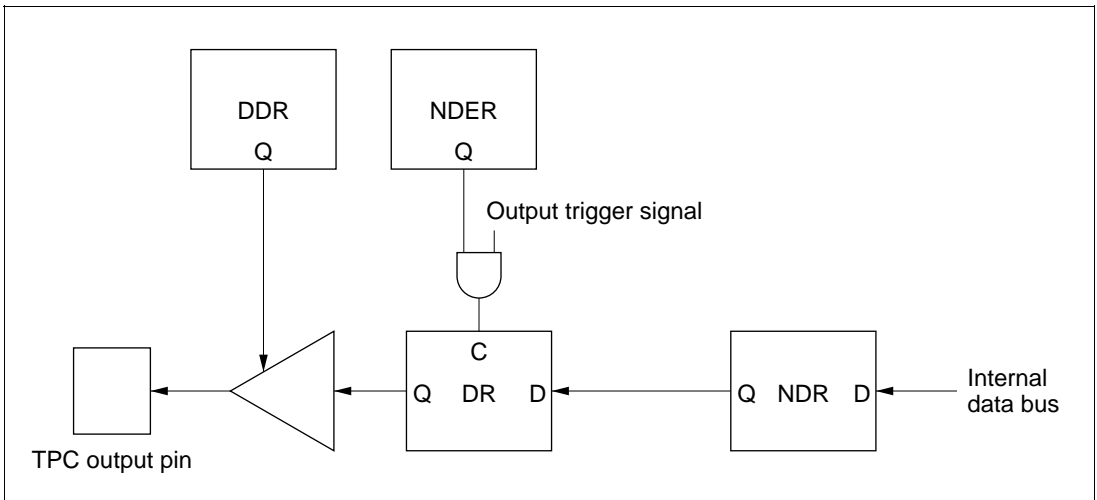

Figure 11.2 TPC Output Operation

Table 11.3 TPC Operating Conditions

NDER	DDR	Pin Function
0	0	Generic input port
	1	Generic output port
1	0	Generic input port (but the DR bit is a read-only bit, and when compare match occurs, the NDR bit value is transferred to the DR bit)
	1	TPC pulse output

Sequential output of up to 16-bit patterns is possible by writing new output data to NDRA and NDRB before the next compare match. For information on non-overlapping operation, see section 11.3.4, Non-Overlapping TPC Output.

11.3.2 Output Timing

If TPC output is enabled, NDRA/NDRB contents are transferred to PADR/PBDR and output when the selected compare match event occurs. Figure 11.3 shows the timing of these operations for the case of normal output in groups 2 and 3, triggered by compare match A.

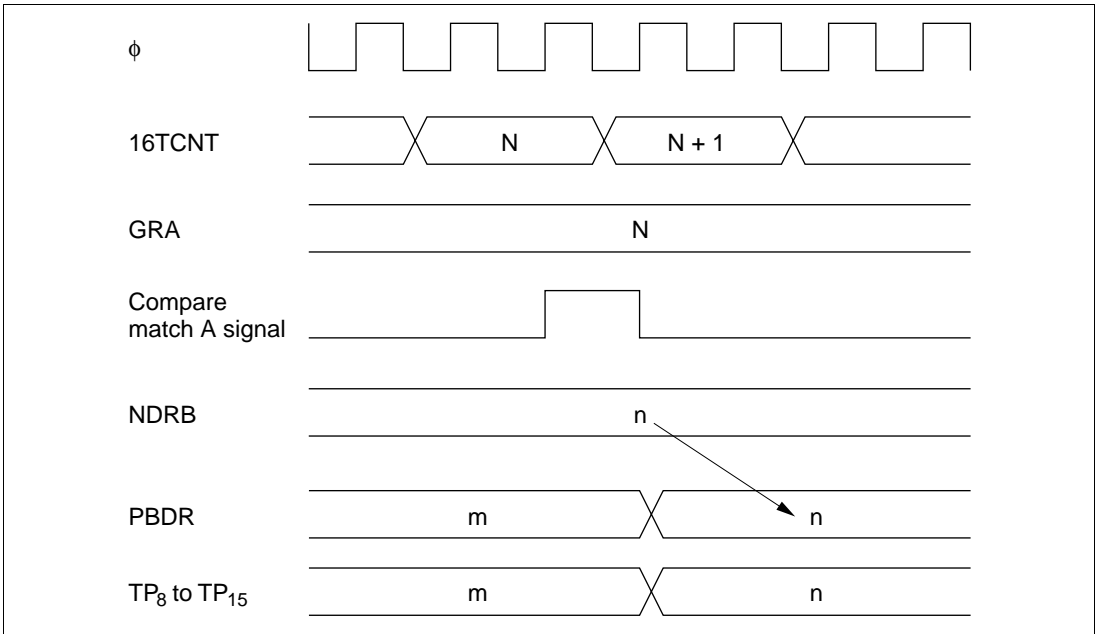

Figure 11.3 Timing of Transfer of Next Data Register Contents and Output (Example)

11.3.3 Normal TPC Output

Sample Setup Procedure for Normal TPC Output: Figure 11.4 shows a sample procedure for setting up normal TPC output.

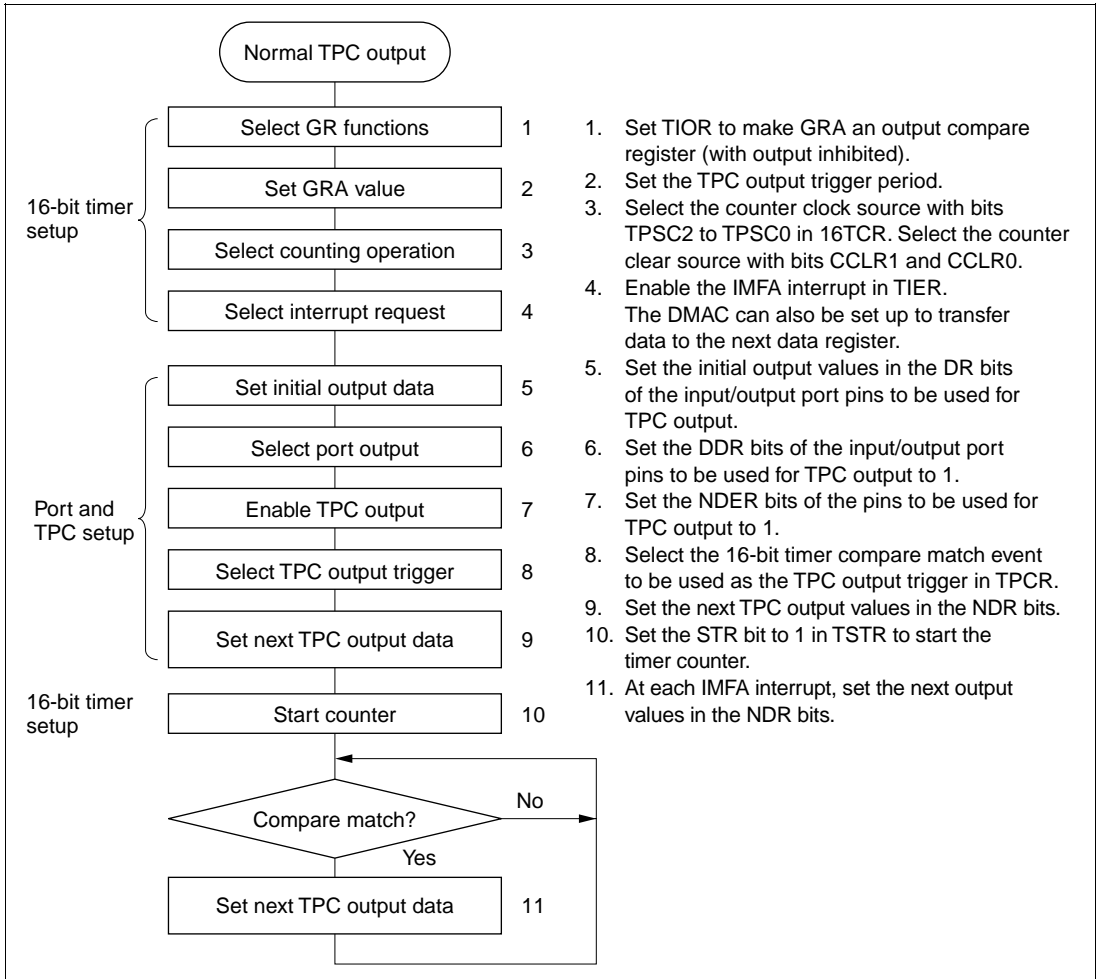

Figure 11.4 Setup Procedure for Normal TPC Output (Example)

Example of Normal TPC Output (Example of Five-Phase Pulse Output): Figure 11.5 shows an example in which the TPC is used for cyclic five-phase pulse output.

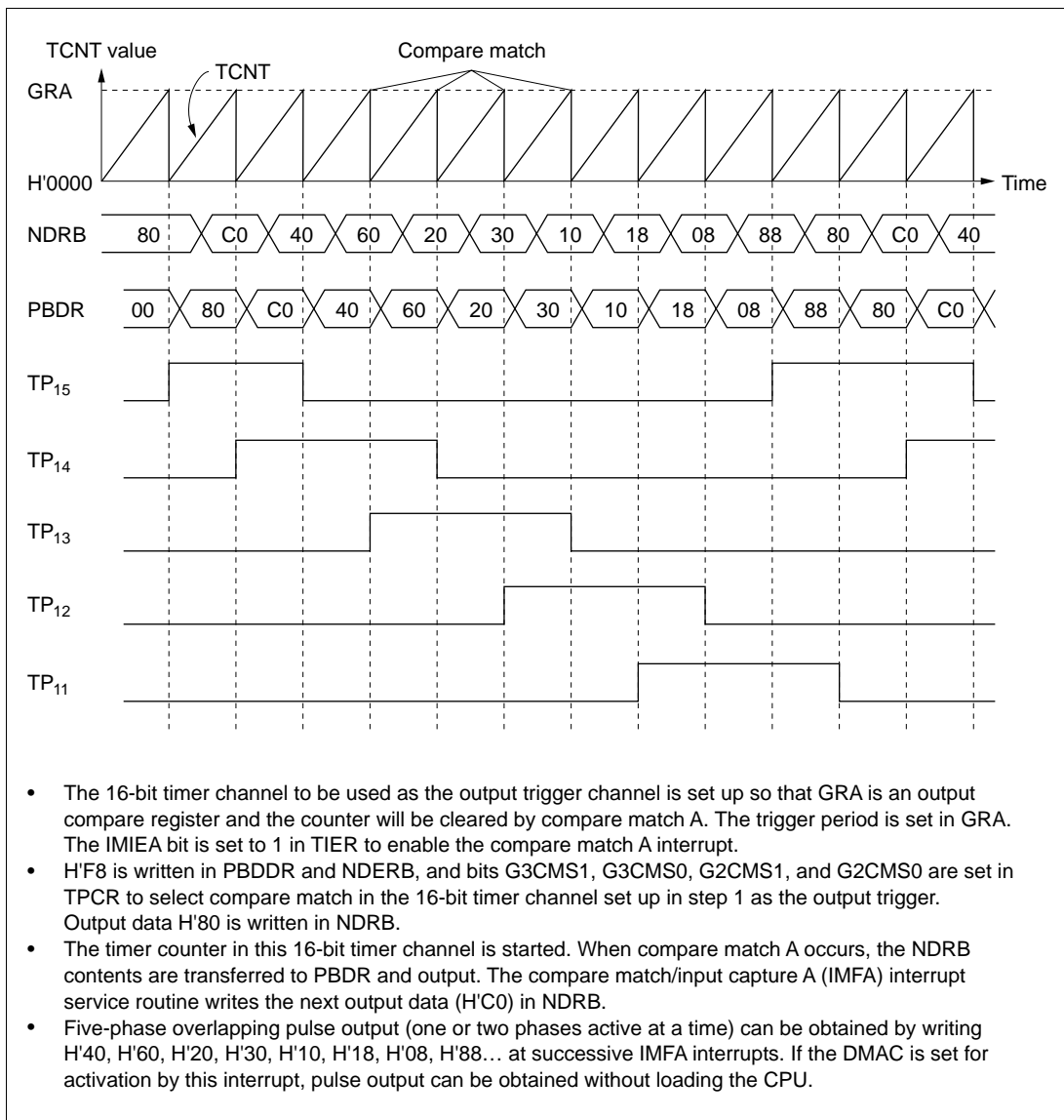

Figure 11.5 Normal TPC Output Example (Five-Phase Pulse Output)

11.3.4 Non-Overlapping TPC Output

Sample Setup Procedure for Non-Overlapping TPC Output: Figure 11.6 shows a sample procedure for setting up non-overlapping TPC output.

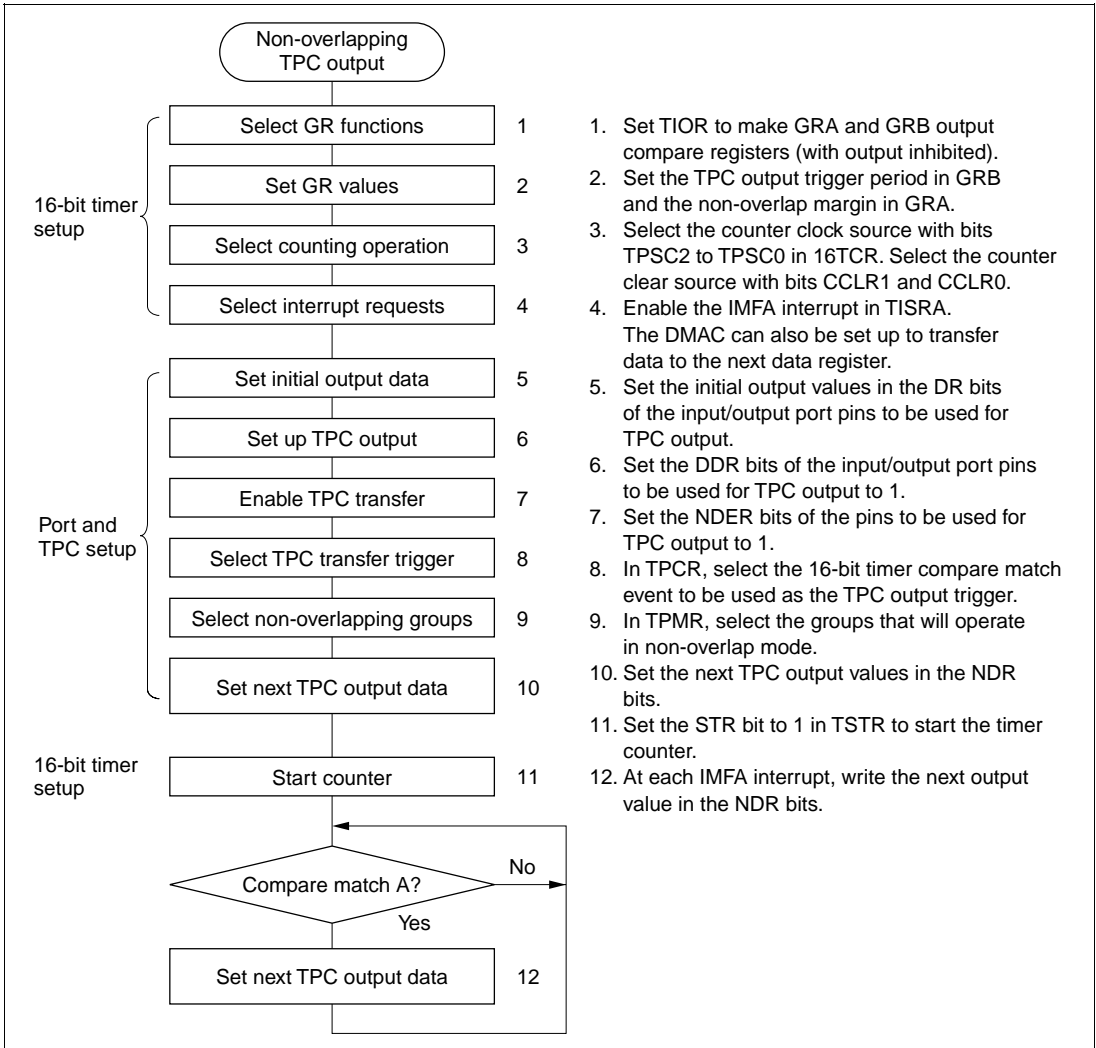
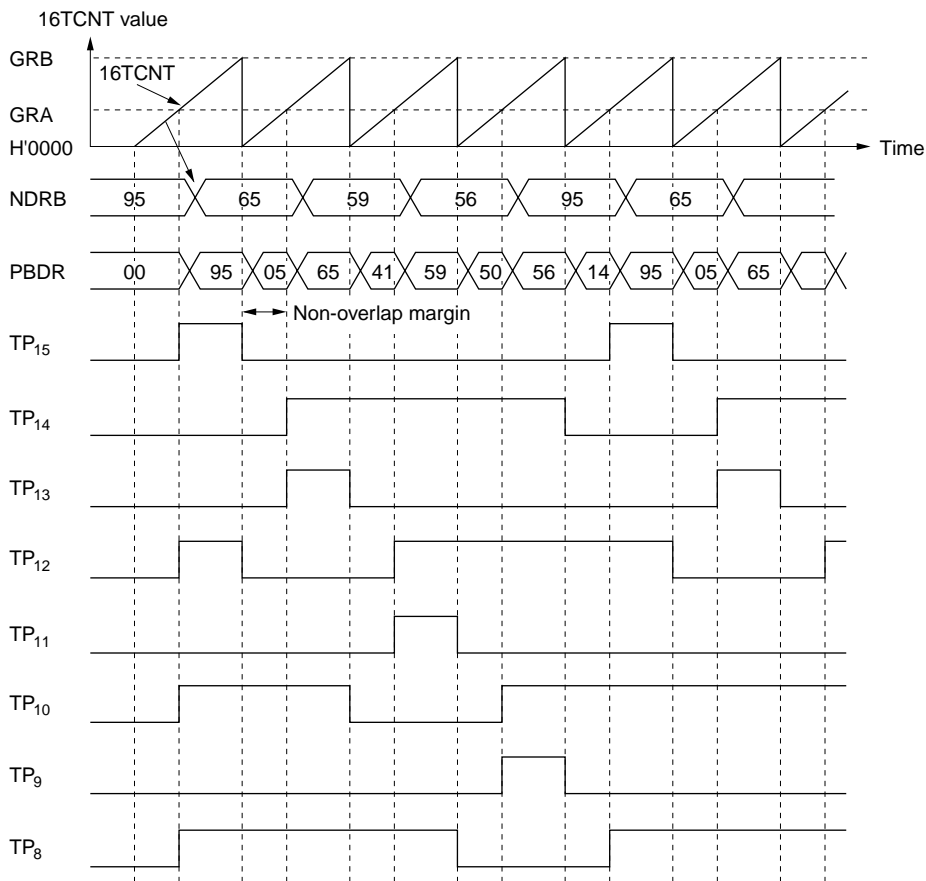

Figure 11.6 Setup Procedure for Non-Overlapping TPC Output (Example)

Example of Non-Overlapping TPC Output (Example of Four-Phase Complementary Non-Overlapping Output): Figure 11.7 shows an example of the use of TPC output for four-phase complementary non-overlapping pulse output.



- The 16-bit timer channel to be used as the output trigger channel is set up so that GRA and GRB are output compare registers and the counter will be cleared by compare match B. The TPC output trigger period is set in GRB. The non-overlap margin is set in GRA. The IMIEA bit is set to 1 in TISRA to enable IMFA interrupts.
- H'FF is written in PBDDR and NDERB, and bits G3CMS1, G3CMS0, G2CMS1, and G2CMS0 are set in TPCR to select compare match in the 16-bit timer channel set up in step 1 as the output trigger. Bits G3NOV and G2NOV are set to 1 in TPMR to select non-overlapping output. Output data H'95 is written in NDRB.
- The timer counter in this 16-bit timer channel is started. When compare match B occurs, outputs change from 1 to 0. When compare match A occurs, outputs change from 0 to 1 (the change from 0 to 1 is delayed by the value of GRA). The IMFA interrupt service routine writes the next output data (H'65) in NDRB.
- Four-phase complementary non-overlapping pulse output can be obtained by writing H'59, H'56, H'95... at successive IMFA interrupts. If the DMAC is set for activation by this interrupt, pulse output can be obtained without loading the CPU.

Figure 11.7 Non-Overlapping TPC Output Example (Four-Phase Complementary Non-Overlapping Pulse Output)

11.3.5 TPC Output Triggering by Input Capture

TPC output can be triggered by 16-bit timer input capture as well as by compare match. If GRA functions as an input capture register in the 16-bit timer channel selected in TPCR, TPC output will be triggered by the input capture signal. Figure 11.8 shows the timing.

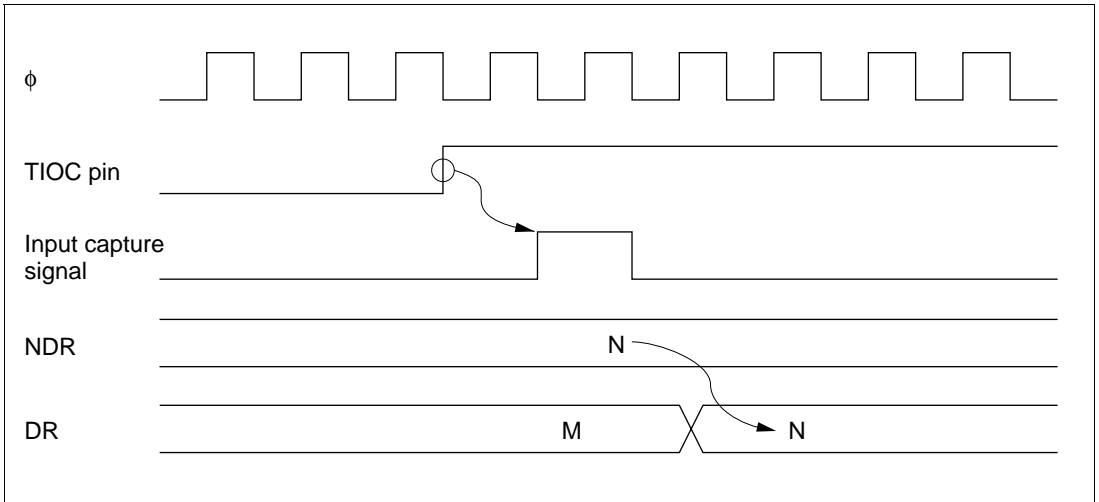

Figure 11.8 TPC Output Triggering by Input Capture (Example)

11.4 Usage Notes

11.4.1 Operation of TPC Output Pins

TP₀ to TP₁₅ are multiplexed with 16-bit timer, DMAC, address bus, and other pin functions. When 16-bit timer, DMAC, or address output is enabled, the corresponding pins cannot be used for TPC output. The data transfer from NDR bits to DR bits takes place, however, regardless of the usage of the pin.

Pin functions should be changed only under conditions in which the output trigger event will not occur.

11.4.2 Note on Non-Overlapping Output

During non-overlapping operation, the transfer of NDR bit values to DR bits takes place as follows.

1. NDR bits are always transferred to DR bits at compare match A.
2. At compare match B, NDR bits are transferred only if their value is 0. Bits are not transferred if their value is 1.

Figure 11.9 illustrates the non-overlapping TPC output operation.

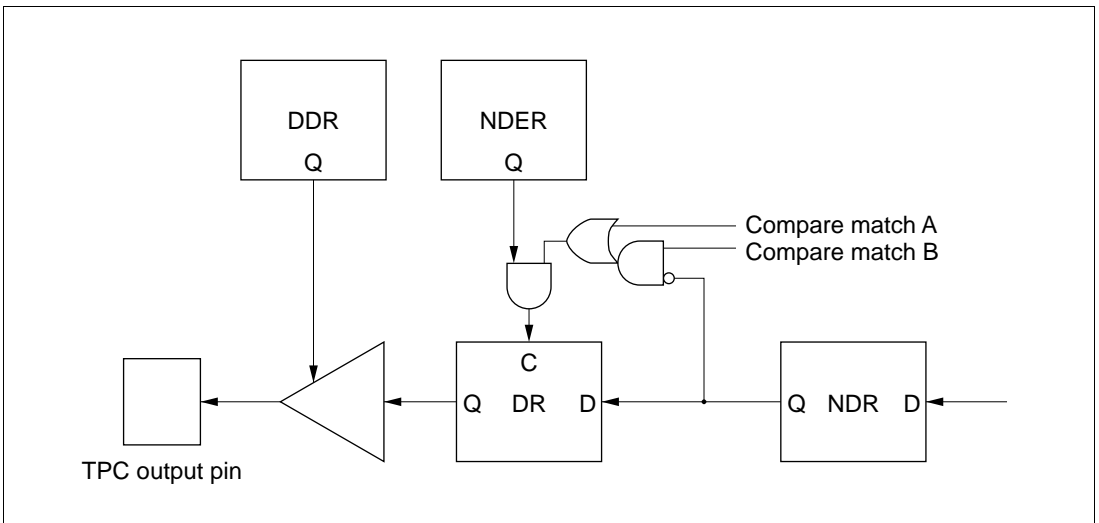

Figure 11.9 Non-Overlapping TPC Output

Therefore, 0 data can be transferred ahead of 1 data by making compare match B occur before compare match A. NDR contents should not be altered during the interval from compare match B to compare match A (the non-overlap margin).

This can be accomplished by having the IMFA interrupt service routine write the next data in NDR, or by having the IMFA interrupt activate the DMAC. The next data must be written before the next compare match B occurs.

Figure 11.10 shows the timing relationships.

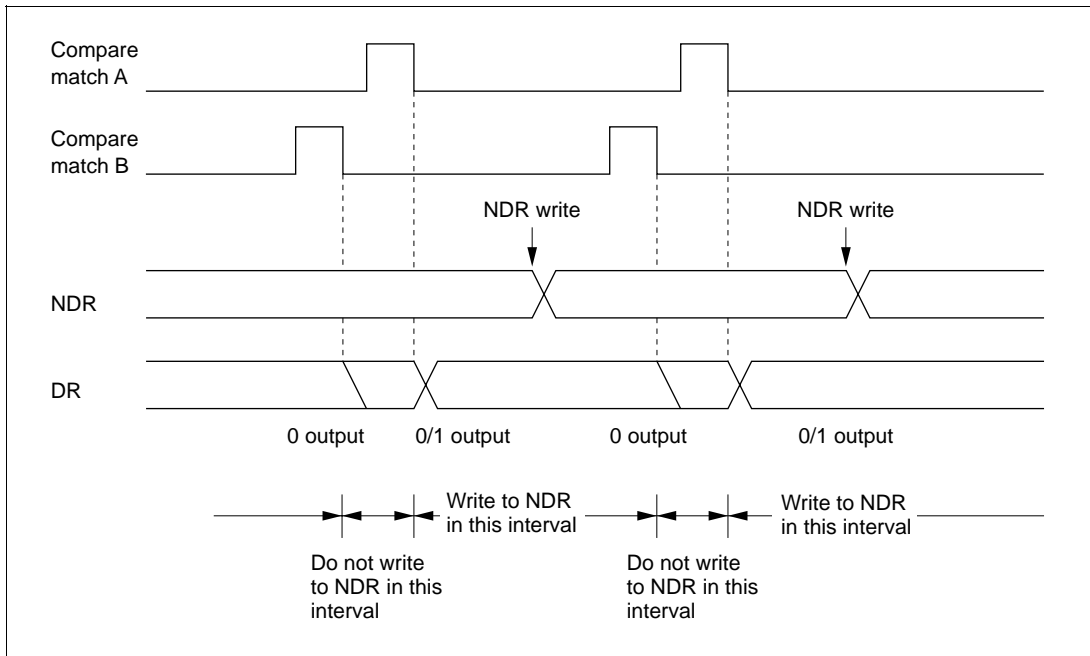

Figure 11.10 Non-Overlapping Operation and NDR Write Timing

Section 12 Watchdog Timer

12.1 Overview

The H8/3006 and H8/3007 have an on-chip watchdog timer (WDT). The WDT has two selectable functions: it can operate as a watchdog timer to supervise system operation, or it can operate as an interval timer. As a watchdog timer, it generates a reset signal for the H8/3006 and H8/3007 chip if a system crash allows the timer counter (TCNT) to overflow before being rewritten. In interval timer operation, an interval timer interrupt is requested at each TCNT overflow.

12.1.1 Features

WDT features are listed below.

- Selection of eight counter clock sources
 $\phi/2$, $\phi/32$, $\phi/64$, $\phi/128$, $\phi/256$, $\phi/512$, $\phi/2048$, or $\phi/4096$
- Interval timer option
- Timer counter overflow generates a reset signal or interrupt.
The reset signal is generated in watchdog timer operation. An interval timer interrupt is generated in interval timer operation.
- Watchdog timer reset signal resets the entire H8/3006 and H8/3007 internally, and can also be output externally.

The reset signal generated by timer counter overflow during watchdog timer operation resets the entire H8/3006 and H8/3007 internally. An external reset signal can be output from the RESO pin to reset other system devices simultaneously.

12.1.2 Block Diagram

Figure 12.1 shows a block diagram of the WDT.

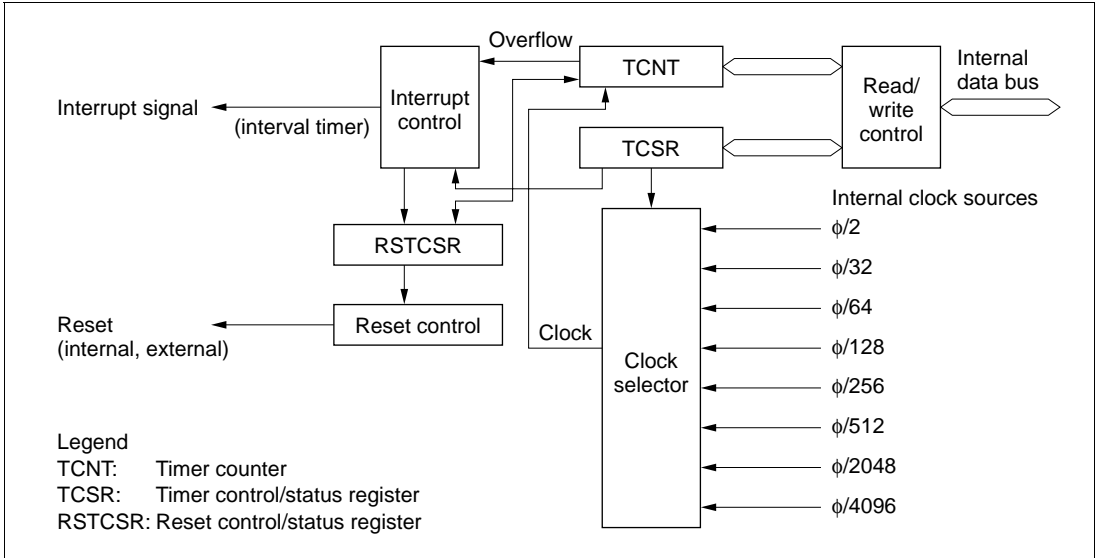

Figure 12.1 WDT Block Diagram

12.1.3 Pin Configuration

Table 12.1 describes the WDT output pin.

Table 12.1 WDT Pin

Name	Abbreviation	I/O	Function
Reset output	$\overline{\text{RESO}}$	Output*	External output of the watchdog timer reset signal

Note: * Open-drain output.

12.1.4 Register Configuration

Table 12.2 summarizes the WDT registers.

Table 12.2 WDT Registers

Address*¹		Name	Abbreviation	R/W	Initial Value
Write*²	Read				
H'FFF8C	H'FFF8C	Timer control/status register	TCSR	R/(W)* ³	H'18
	H'FFF8D	Timer counter	TCNT	R/W	H'00
H'FFF8E	H'FFF8F	Reset control/status register	RSTCSR	R/(W) * ³	H'3F

Notes: 1. Lower 20 bits of the address in advanced mode.
2. Write word data starting at this address.
3. Only 0 can be written in bit 7, to clear the flag.

12.2 Register Descriptions

12.2.1 Timer Counter (TCNT)

TCNT is an 8-bit readable and writable up-counter.

Bit	7	6	5	4	3	2	1	0
Initial value	0	0	0	0	0	0	0	0
Read/Write	R/W	R/W	R/W	R/W	R/W	R/W	R/W	R/W

Note: TCNT is write-protected by a password. For details see section 12.2.4, Notes on Register Access.

When the TME bit is set to 1 in TCSR, TCNT starts counting pulses generated from an internal clock source selected by bits CKS2 to CKS0 in TCSR. When the count overflows (changes from H'FF to H'00), the OVF bit is set to 1 in TCSR. TCNT is initialized to H'00 by a reset and when the TME bit is cleared to 0.

12.2.2 Timer Control/Status Register (TCSR)

TCSR is an 8-bit readable and writable register. Its functions include selecting the timer mode and clock source.

Bit	7	6	5	4	3	2	1	0
	OVF	WT/ \overline{IT}	TME	—	—	CKS2	CKS1	CKS0
Initial value	0	0	0	1	1	0	0	0
Read/Write	R/(W)*	R/W	R/W	—	—	R/W	R/W	R/W

Overflow flag
 Status flag indicating overflow

Timer mode select
 Selects the mode

Timer enable
 Selects whether TCNT runs or halts

Reserved bits

Clock select
 These bits select the TCNT clock source

Notes: TCSR is write-protected by a password. For details see section 12.2.4, Notes on Register Access.

* Only 0 can be written, to clear the flag.

Bits 7 to 5 are initialized to 0 by a reset and in standby mode. Bits 2 to 0 are initialized to 0 by a reset. In software standby mode bits 2 to 0 are not initialized, but retain their previous values.

Bit 7—Overflow Flag (OVF): This status flag indicates that the timer counter has overflowed from H'FF to H'00.

Bit 7 OVF	Description
0	[Clearing condition] Cleared by reading OVF when OVF = 1, then writing 0 in OVF (Initial value)
1	[Setting condition] Set when TCNT changes from H'FF to H'00

Bit 6—Timer Mode Select (WT/IT): Selects whether to use the WDT as a watchdog timer or interval timer. If used as an interval timer, the WDT generates an interval timer interrupt request when TCNT overflows. If used as a watchdog timer, the WDT generates a reset signal when TCNT overflows.

Bit 6 WT/IT	Description
0	Interval timer: requests interval timer interrupts (Initial value)
1	Watchdog timer: generates a reset signal

Bit 5—Timer Enable (TME): Selects whether TCNT runs or is halted. When $\overline{WT/IT} = 1$, clear the software standby bit (SSBY) to 0 in SYSCR before setting TME. When setting SSBY to 1, TME should be cleared to 0.

Bit 5 TME	Description
0	TCNT is initialized to H'00 and halted (Initial value)
1	TCNT is counting

Bits 4 and 3—Reserved: These bits cannot be modified and are always read as 1.

Bits 2 to 0—Clock Select 2 to 0 (CKS2/1/0): These bits select one of eight internal clock sources, obtained by prescaling the system clock (ϕ), for input to TCNT.

Bit 2 CKS2	Bit 1 CKS1	Bit 0 CKS0	Description
0	0	0	$\phi/2$ (Initial value)
		1	$\phi/32$
	1	0	$\phi/64$
		1	$\phi/128$
1	0	0	$\phi/256$
		1	$\phi/512$
	1	0	$\phi/2048$
		1	$\phi/4096$

12.2.3 Reset Control/Status Register (RSTCSR)

RSTCSR is an 8-bit readable and writable register that indicates when a reset signal has been generated by watchdog timer overflow, and controls external output of the reset signal.

Bit	7	6	5	4	3	2	1	0
	WRST	RSTOE	—	—	—	—	—	—
Initial value	0	0	1	1	1	1	1	1
Read/Write	R/(W)*	R/W	—	—	—	—	—	—

Reserved bits

Reset output enable
Enables or disables external output of the reset signal

Watchdog timer reset
Indicates that a reset signal has been generated

Notes: RSTCSR is write-protected by a password. For details see section 12.2.4, Notes on Register Access.

* Only 0 can be written in bit 7, to clear the flag.

Bits 7 and 6 are initialized by input of a reset signal at the $\overline{\text{RES}}$ pin. They are not initialized by reset signals generated by watchdog timer overflow.

Bit 7—Watchdog Timer Reset (WRST): During watchdog timer operation, this bit indicates that TCNT has overflowed and generated a reset signal. This reset signal resets the entire H8/3006 and H8/3007 chip internally. If bit RSTOE is set to 1, this reset signal is also output (low) at the $\overline{\text{RESO}}$ pin to initialize external system devices.

Bit 7		
WRST	Description	
0	[Clearing condition] Reset signal at $\overline{\text{RES}}$ pin. Read WRST when WRST =1, then write 0 in WRST.	(Initial value)
1	[Setting condition] Set when TCNT overflow generates a reset signal during watchdog timer operation	

Bit 6—Reset Output Enable (RSTOE): Enables or disables external output at the $\overline{\text{RESO}}$ pin of the reset signal generated if TCNT overflows during watchdog timer operation.

Bit 6		
RSTOE	Description	
0	Reset signal is not output externally	(Initial value)
1	Reset signal is output externally	

Bits 5 to 0—Reserved: These bits cannot be modified and are always read as 1.

12.2.4 Notes on Register Access

The watchdog timer's TCNT, TCSR, and RSTCSR registers differ from other registers in being more difficult to write. The procedures for writing and reading these registers are given below.

Writing to TCNT and TCSR: These registers must be written by a word transfer instruction. They cannot be written by byte instructions. Figure 12.2 shows the format of data written to TCNT and TCSR. TCNT and TCSR both have the same write address. The write data must be contained in the lower byte of the written word. The upper byte must contain H'5A (password for TCNT) or H'A5 (password for TCSR). This transfers the write data from the lower byte to TCNT or TCSR.

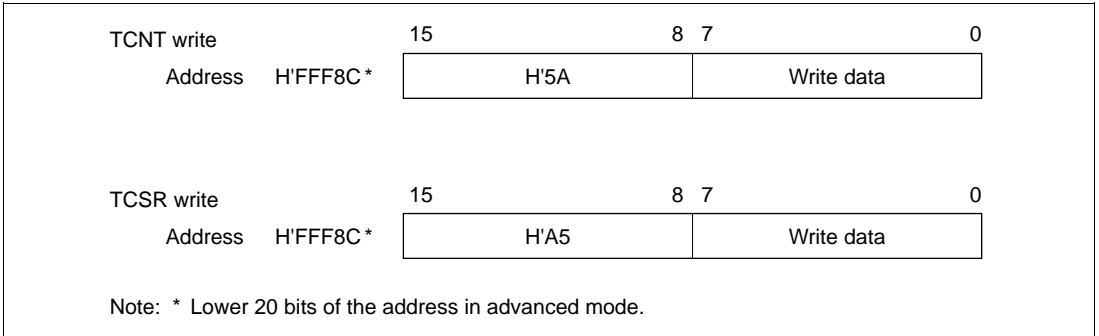

Figure 12.2 Format of Data Written to TCNT and TCSR

Writing to RSTCSR: RSTCSR must be written by a word transfer instruction. It cannot be written by byte transfer instructions. Figure 12.3 shows the format of data written to RSTCSR. To write 0 in the WRST bit, the write data must have H'A5 in the upper byte and H'00 in the lower byte. The data (H'00) in the lower byte is written to RSTCSR, clearing the WRST bit to 0. To write to the RSTOE bit, the upper byte must contain H'5A and the lower byte must contain the write data. Writing this word transfers a write data value into the RSTOE bit.

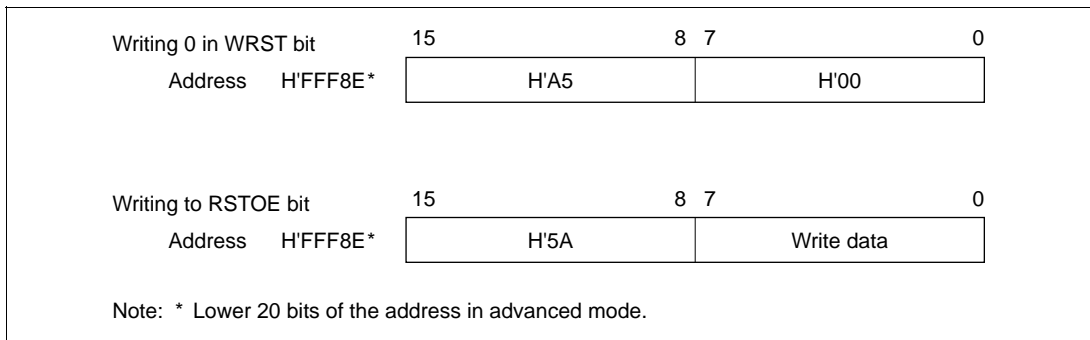

Figure 12.3 Format of Data Written to RSTCSR

Reading TCNT, TCSR, and RSTCSR: These registers are read like other registers. Reading TCNT, TCSR, and RSTCSR: These registers are read like other registers. Byte transfer instructions can be used. The read addresses are H'FFF8C for TCSR, H'FFF8D for TCNT, and H'FFF8F for RSTCSR, as listed in table 12-3.

Table 12.3 Read Addresses of TCNT, TCSR, and RSTCSR

Address*	Register
H'FFF8C	TCSR
H'FFF8D	TCNT
H'FFF8F	RSTCSR

Note: * Lower 20 bits of the address in advanced mode.

12.3 Operation

Operations when the WDT is used as a watchdog timer and as an interval timer are described below.

12.3.1 Watchdog Timer Operation

Figure 12.4 illustrates watchdog timer operation. To use the WDT as a watchdog timer, set the $\overline{WT/IT}$ and TME bits to 1 in TCSR. Software must prevent TCNT overflow by rewriting the TCNT value (normally by writing H'00) before overflow occurs. If TCNT fails to be rewritten and overflows due to a system crash etc., the H8/3006 and H8/3007 are internally reset for a duration of 518 states.

The watchdog reset signal can be externally output from the \overline{RESO} pin to reset external system devices. The reset signal is output externally for 132 states. External output can be enabled or disabled by the RSTOE bit in RSTCSR.

A watchdog reset has the same vector as a reset generated by input at the \overline{RES} pin. Software can distinguish a \overline{RES} reset from a watchdog reset by checking the WRST bit in RSTCSR.

If a \overline{RES} reset and a watchdog reset occur simultaneously, the \overline{RES} reset takes priority.

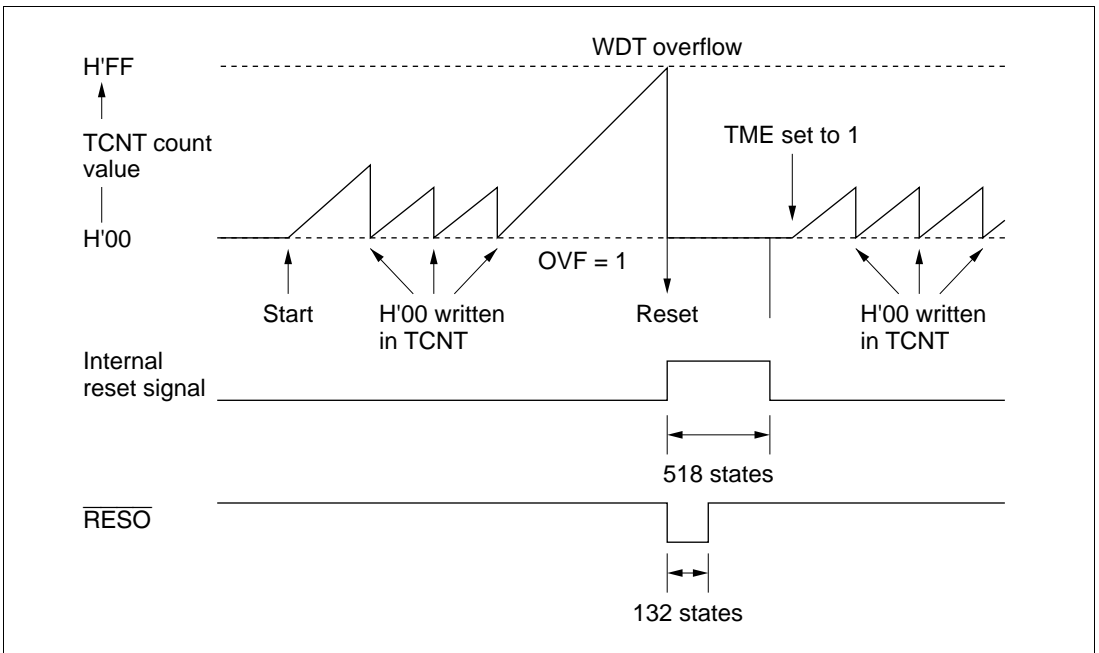

Figure 12.4 Operation in Watchdog Timer Mode

12.3.2 Interval Timer Operation

Figure 12.5 illustrates interval timer operation. To use the WDT as an interval timer, clear bit $\overline{WT/IT}$ to 0 and set bit TME to 1 in TCSR. An interval timer interrupt request is generated at each TCNT overflow. This function can be used to generate interval timer interrupts at regular intervals.

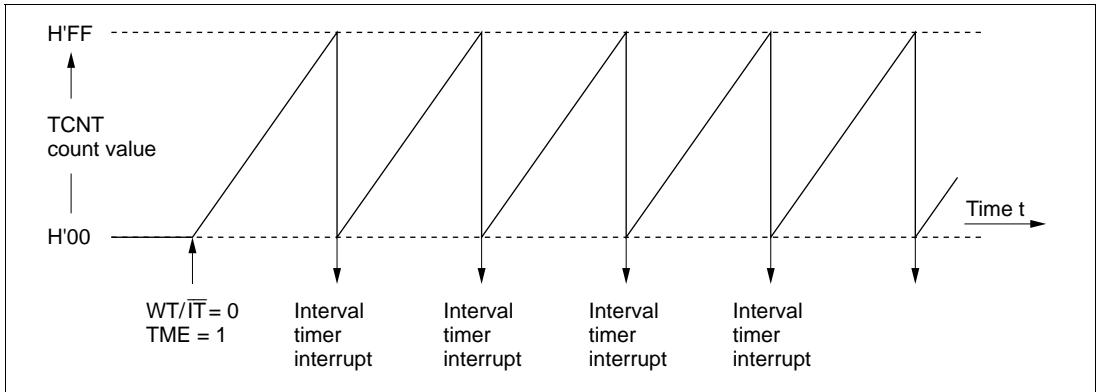

Figure 12.5 Interval Timer Operation

12.3.3 Timing of Setting of Overflow Flag (OVF)

Figure 12.6 shows the timing of setting of the OVF flag. The OVF flag is set to 1 when TCNT overflows. At the same time, a reset signal is generated in watchdog timer operation, or an interval timer interrupt is generated in interval timer operation.

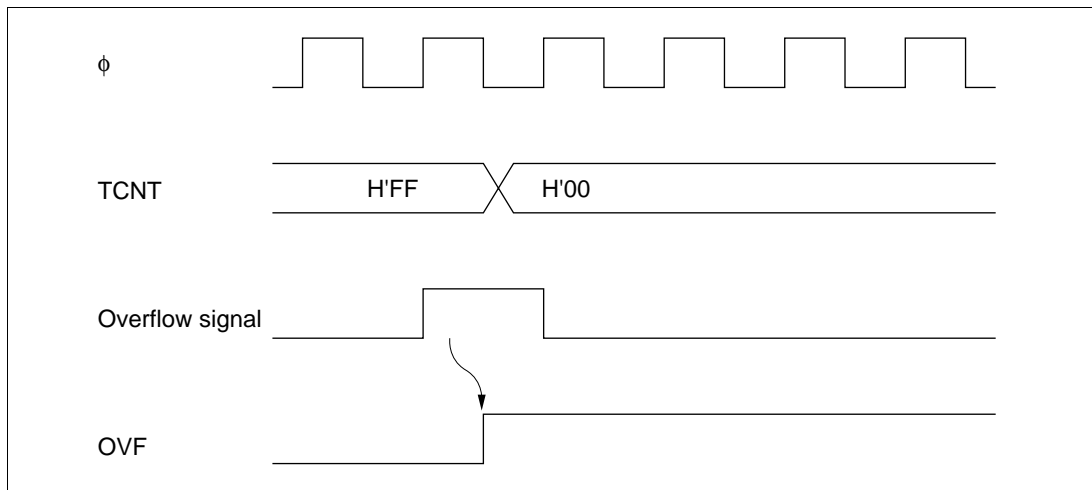

Figure 12.6 Timing of Setting of OVF

12.3.4 Timing of Setting of Watchdog Timer Reset Bit (WRST)

The WRST bit in RSTCSR is valid when bits WT/\overline{IT} and TME are both set to 1 in TCSR.

Figure 12.7 shows the timing of setting of WRST and the internal reset timing. The WRST bit is set to 1 when TCNT overflows and OVF is set to 1. At the same time an internal reset signal is generated for the entire H8/3006 and H8/3007 chip. This internal reset signal clears OVF to 0, but the WRST bit remains set to 1. The reset routine must therefore clear the WRST bit.

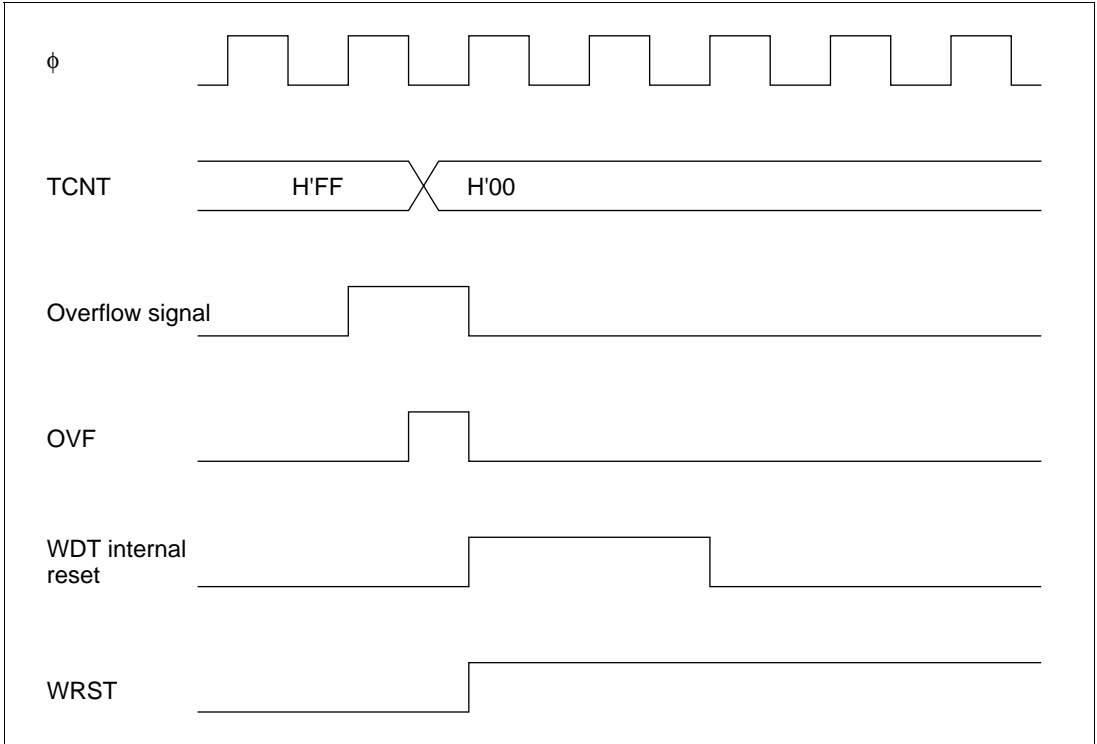

Figure 12.7 Timing of Setting of WRST Bit and Internal Reset

12.4 Interrupts

During interval timer operation, an overflow generates an interval timer interrupt (WOVI). The interval timer interrupt is requested whenever the OVF bit is set to 1 in TCSR.

12.5 Usage Notes

Contention between TCNT Write and Increment: If a timer counter clock pulse is generated during the T_3 state of a write cycle to TCNT, the write takes priority and the timer count is not incremented. See figure 12.8.

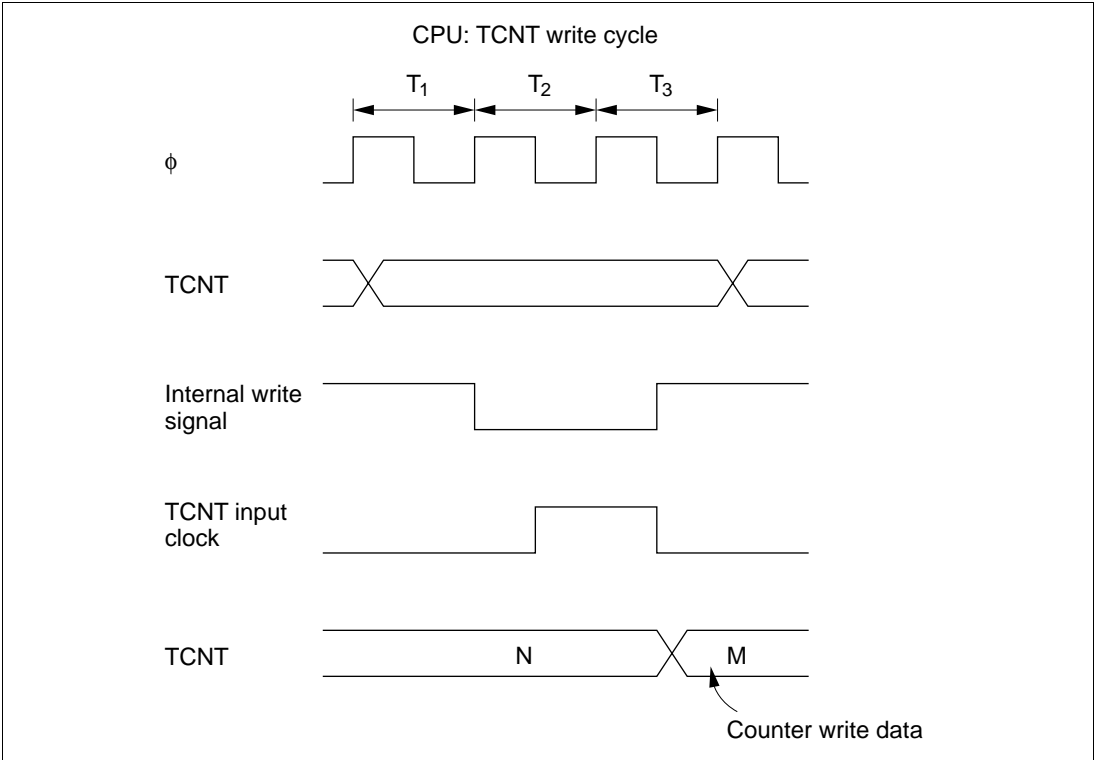

Figure 12.8 Contention between TCNT Write and Count up

Changing CKS2 to CKS0 Bit: Halt TCNT by clearing the TME bit to 0 in TCSR before changing the values of bits CKS2 to CKS0.

Section 13 Serial Communication Interface

13.1 Overview

The H8/3006 and H8/3007 have a serial communication interface (SCI) with three independent channels. The SCI can communicate in both asynchronous and synchronous mode. It also has a multiprocessor communication function for serial communication among two or more processors.

When the SCI is not used, it can be halted to conserve power. Each SCI channel can be halted independently. For details, see section 19.6, Module Standby Function.

The SCI also has a smart card interface function conforming to the ISO/IEC 7816-3 (Identification Card) standard. This function supports serial communication with a smart card. Switching between the normal serial communication interface and the smart card interface is carried out by means of a register setting.

13.1.1 Features

SCI features are listed below.

- Selection of synchronous or asynchronous mode for serial communication

Asynchronous mode

Serial data communication is synchronized one channel at a time. The SCI can communicate with a universal asynchronous receiver/transmitter (UART), asynchronous communication interface adapter (ACIA), or other chip that employs standard asynchronous communication. It can also communicate with two or more other processors using the multiprocessor communication function. There are twelve selectable serial data transfer formats.

- Data length: 7 or 8 bits
- Stop bit length: 1 or 2 bits
- Parity: even/odd/none
- Multiprocessor bit: 1 or 0
- Receive error detection: parity, overrun, and framing errors
- Break detection: by reading the RxD level directly when a framing error occurs

Synchronous mode

Serial data communication is synchronized with a clock signal. The SCI can communicate with other chips having a synchronous communication function.

There is a single serial data communication format.

- Data length: 8 bits
- Receive error detection: overrun errors

- Full-duplex communication
The transmitting and receiving sections are independent, so the SCI can transmit and receive simultaneously. The transmitting and receiving sections are both double-buffered, so serial data can be transmitted and received continuously.
- The following settings can be made for the serial data to be transferred:
 - LSB-first or MSB-first transfer
 - Inversion of data logic level
- Built-in baud rate generator with selectable bit rates
- Selectable transmit/receive clock sources: internal clock from baud rate generator, or external clock from the SCK pin
- Four types of interrupts
Transmit-data-empty, transmit-end, receive-data-full, and receive-error interrupts are requested independently. The transmit-data-empty and receive-data-full interrupts from SCI0 can activate the DMA controller (DMAC) to transfer data.

Features of the smart card interface are listed below.

- Asynchronous communication
 - Data length: 8 bits
 - Parity bits generated and checked
 - Error signal output in receive mode (parity error)
 - Error signal detect and automatic data retransmit in transmit mode
 - Supports both direct convention and inverse convention
- Built-in baud rate generator with selectable bit rates
- Three types of interrupts
Transmit-data-empty, receive-data-full, and transmit/receive-error interrupts are requested independently. The transmit-data-empty and receive-data-full interrupts can activate the DMA controller (DMAC) to transfer data.

13.1.2 Block Diagram

Figure 13.1 shows a block diagram of the SCI.

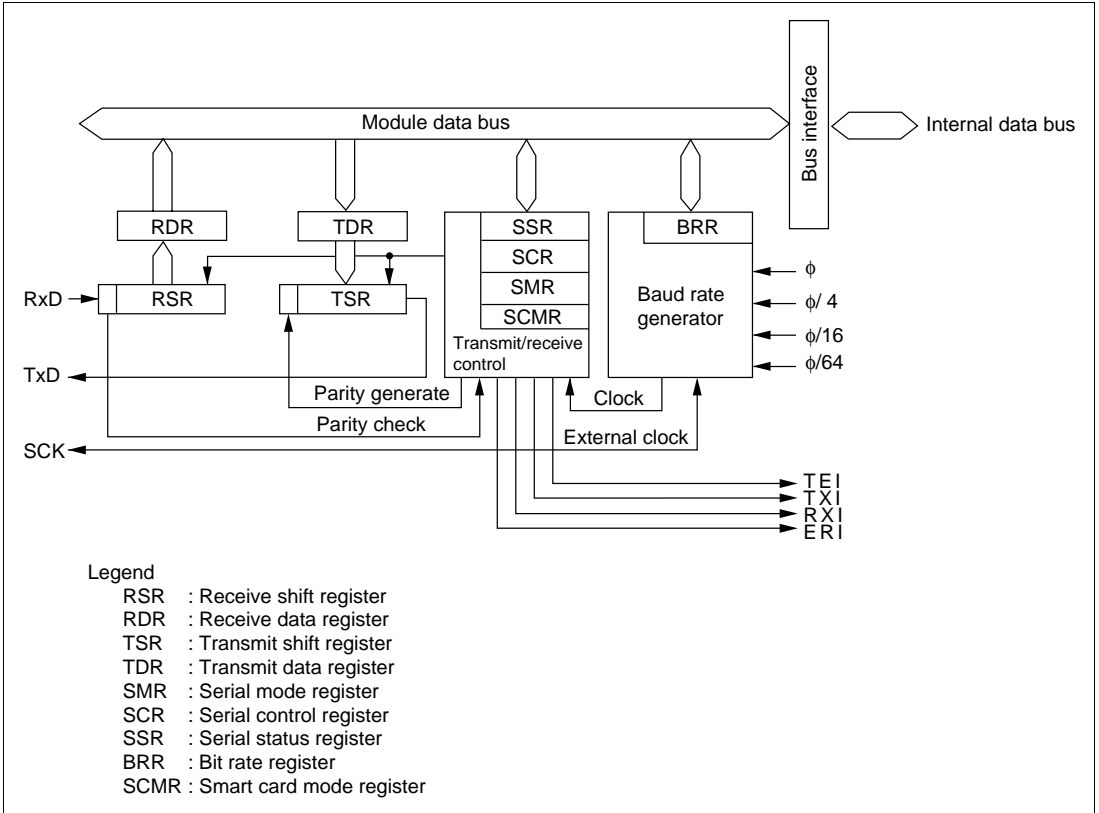

Figure 13.1 SCI Block Diagram

13.1.3 Pin Configuration

The SCI has serial pins for each channel as listed in table 13.1.

Table 13.1 SCI Pins

Channel	Name	Abbreviation	I/O	Function
0	Serial clock pin	SCK ₀	Input/output	SCI ₀ clock input/output
	Receive data pin	RxD ₀	Input	SCI ₀ receive data input
	Transmit data pin	TxD ₀	Output	SCI ₀ transmit data output
1	Serial clock pin	SCK ₁	Input/output	SCI ₁ clock input/output
	Receive data pin	RxD ₁	Input	SCI ₁ receive data input
	Transmit data pin	TxD ₁	Output	SCI ₁ transmit data output
2	Serial clock pin	SCK ₂	Input/output	SCI ₂ clock input/output
	Receive data pin	RxD ₂	Input	SCI ₂ receive data input
	Transmit data pin	TxD ₂	Output	SCI ₂ transmit data output

13.1.4 Register Configuration

The SCI has internal registers as listed in table 13.2. These registers select asynchronous or synchronous mode, specify the data format and bit rate, control the transmitter and receiver sections, and specify switching between the serial communication interface and smart card interface.

Table 13.2 SCI Registers

Channel	Address* ¹	Name	Abbreviation	R/W	Initial Value
0	H'FFFB0	Serial mode register	SMR	R/W	H'00
	H'FFFB1	Bit rate register	BRR	R/W	H'FF
	H'FFFB2	Serial control register	SCR	R/W	H'00
	H'FFFB3	Transmit data register	TDR	R/W	H'FF
	H'FFFB4	Serial status register	SSR	R/(W)* ²	H'84
	H'FFFB5	Receive data register	RDR	R	H'00
	H'FFFB6	Smart card mode register	SCMR	R/W	H'F2
1	H'FFFB8	Serial mode register	SMR	R/W	H'00
	H'FFFB9	Bit rate register	BRR	R/W	H'FF
	H'FFBBA	Serial control register	SCR	R/W	H'00
	H'FFBBB	Transmit data register	TDR	R/W	H'FF
	H'FFBBC	Serial status register	SSR	R/(W)* ²	H'84
	H'FFBBD	Receive data register	RDR	R	H'00
	H'FFBBE	Smart card mode register	SCMR	R/W	H'F2
2	H'FFFC0	Serial mode register	SMR	R/W	H'00
	H'FFFC1	Bit rate register	BRR	R/W	H'FF
	H'FFFC2	Serial control register	SCR	R/W	H'00
	H'FFFC3	Transmit data register	TDR	R/W	H'FF
	H'FFFC4	Serial status register	SSR	R/(W)* ²	H'84
	H'FFFC5	Receive data register	RDR	R	H'00
	H'FFFC6	Smart card mode register	SCMR	R/W	H'F2

- Notes: 1. Indicates the lower 20 bits of the address in advanced mode.
 2. Only 0 can be written, to clear flags.

13.2 Register Descriptions

13.2.1 Receive Shift Register (RSR)

RSR is the register that receives serial data.

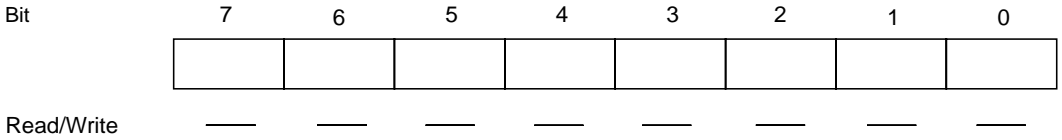

The SCI loads serial data input at the RxD pin into RSR in the order received, LSB (bit 0) first, thereby converting the data to parallel data. When one byte of data has been received, it is automatically transferred to RDR. The CPU cannot read or write RSR directly.

13.2.2 Receive Data Register (RDR)

RDR is the register that stores received serial data.

Bit	7	6	5	4	3	2	1	0
	<input type="checkbox"/>	<input type="checkbox"/>	<input type="checkbox"/>	<input type="checkbox"/>	<input type="checkbox"/>	<input type="checkbox"/>	<input type="checkbox"/>	<input type="checkbox"/>
Initial value	0	0	0	0	0	0	0	0
Read/Write	R	R	R	R	R	R	R	R

When the SCI has received one byte of serial data, it transfers the received data from RSR into RDR for storage, completing the receive operation. RSR is then ready to receive the next data. This double-buffering allows data to be received continuously.

RDR is a read-only register. Its contents cannot be modified by the CPU. RDR is initialized to H'00 by a reset and in standby mode.

13.2.3 Transmit Shift Register (TSR)

TSR is the register that transmits serial data.

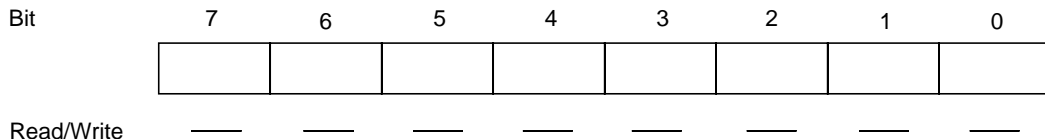

The SCI loads transmit data from TDR to TSR, then transmits the data serially from the TxD pin, LSB (bit 0) first. After transmitting one data byte, the SCI automatically loads the next transmit data from TDR into TSR and starts transmitting it. If the TDRE flag is set to 1 in SSR, however, the SCI does not load the TDR contents into TSR. The CPU cannot read or write RSR directly.

13.2.4 Transmit Data Register (TDR)

TDR is an 8-bit register that stores data for serial transmission.

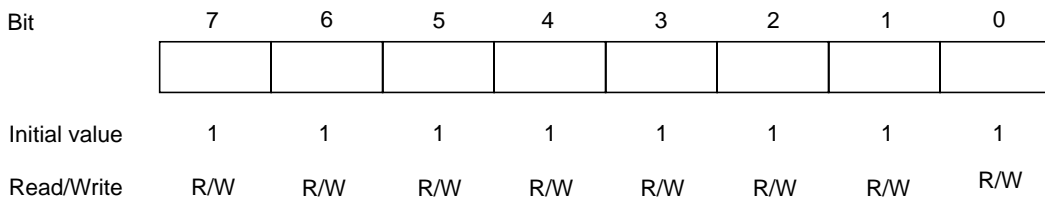

When the SCI detects that TSR is empty, it moves transmit data written in TDR from TDR into TSR and starts serial transmission. Continuous serial transmission is possible by writing the next transmit data in TDR during serial transmission from TSR.

The CPU can always read and write TDR. TDR is initialized to H'FF by a reset and in standby mode.

13.2.5 Serial Mode Register (SMR)

SMR is an 8-bit register that specifies the SCI's serial communication format and selects the clock source for the baud rate generator.

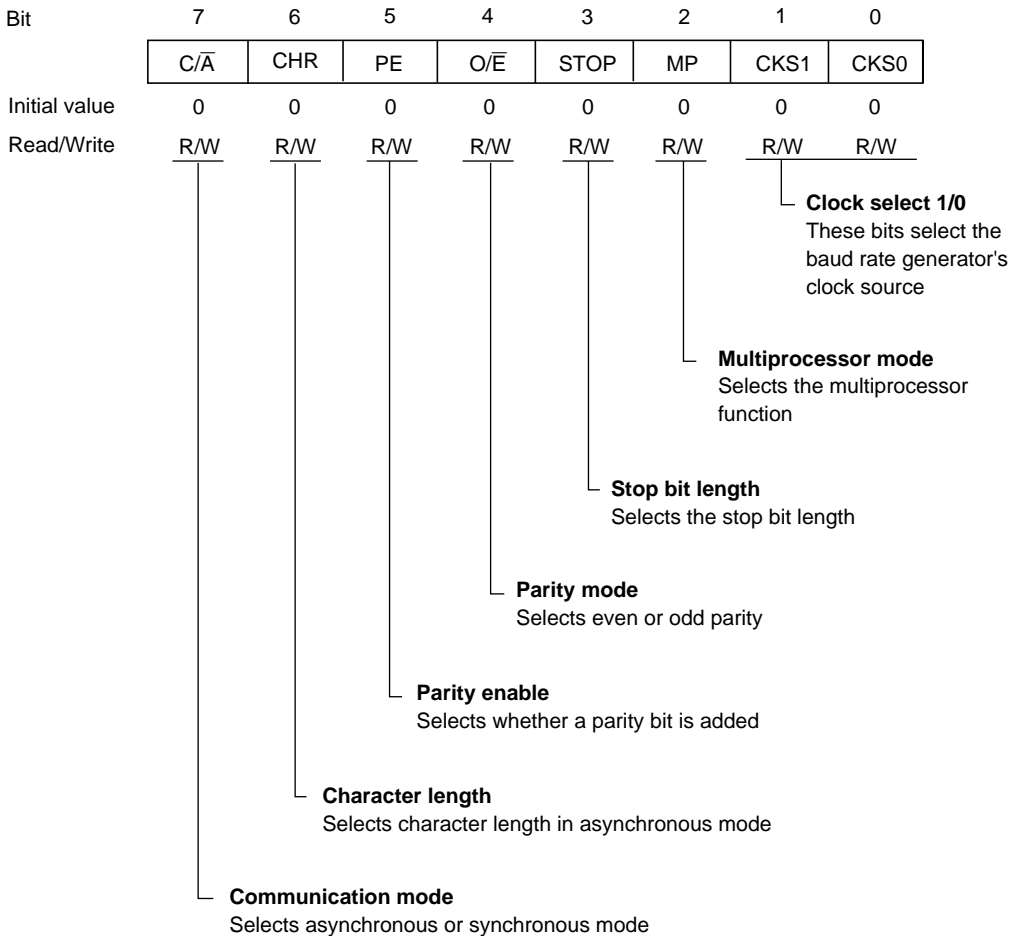

The CPU can always read and write SMR. SMR is initialized to H'00 by a reset and in standby mode.

Bit 7—Communication Mode (C/ \bar{A})/GSM Mode (GM): The function of this bit differs for the normal serial communication interface and for the smart card interface. Its function is switched with the SMIF bit in SCMR.

For serial communication interface (SMIF bit in SCMR cleared to 0): Selects whether the SCI operates in asynchronous or synchronous mode.

Bit 7 C/A	Description
0	Asynchronous mode (Initial value)
1	Synchronous mode

For smart card interface (SMIF bit in SCMR set to 1): Selects GSM mode for the smart card interface.

Bit 7 GM	Description
0	The TEND flag is set 12.5 etu after the start bit (Initial value)
1	The TEND flag is set 11.0 etu after the start bit

Note: etu: Elementary time unit (time required to transmit one bit)

Bit 6—Character Length (CHR): Selects 7-bit or 8-bits data length in asynchronous mode. In synchronous mode, the data length is 8 bits regardless of the CHR setting,

Bit 6 CHR	Description
0	8-bit data (Initial value)
1	7-bit data*

Note: * When 7-bit data is selected, the MSB (bit 7) of TDR is not transmitted.

Bit 5—Parity Enable (PE): In asynchronous mode, this bit enables or disables the addition of a parity bit to transmit data, and the checking of the parity bit in receive data. In synchronous mode, the parity bit is neither added nor checked, regardless of the PE bit setting.

Bit 5 PE	Description
0	Parity bit not added or checked (Initial value)
1	Parity bit added and checked*

Note: * When PE bit is set to 1, an even or odd parity bit is added to transmit data according to the even or odd parity mode selection by the O/ \bar{E} bit, and the parity bit in receive data is checked to see that it matches the even or odd mode selected by the O/ \bar{E} bit.

Bit 4—Parity Mode (O/E): Selects even or odd parity. The O/E bit setting is only valid when the PE bit is set to 1, enabling parity bit addition and checking, in asynchronous mode. The O/E bit setting is ignored in synchronous mode, or when parity addition and checking is disabled in asynchronous mode.

Bit 4 O/E	Description
0	Even parity* ¹ (Initial value)
1	Odd parity* ²

Notes: 1. When even parity is selected, the parity bit added to transmit data makes an even number of 1s in the transmitted character and parity bit combined. Receive data must have an even number of 1s in the received character and parity bit combined.

2. When odd parity is selected, the parity bit added to transmit data makes an odd number of 1s in the transmitted character and parity bit combined. Receive data must have an odd number of 1s in the received character and parity bit combined.

Bit 3—Stop Bit Length (STOP): Selects one or two stop bits in asynchronous mode. This setting is used only in asynchronous mode. In synchronous mod no stop bit is added, so the STOP bit setting is ignored.

Bit 3 STOP	Description
0	1 stop bit* ¹ (Initial value)
1	2 stop bits* ²

Notes: 1. One stop bit (with value 1) is added to the end of each transmitted character.

2. Two stop bits (with value 1) are added to the end of each transmitted character.

In receiving, only the first stop bit is checked, regardless of the STOP bit setting. If the second stop bit is 1, it is treated as a stop bit. If the second stop bit is 0, it is treated as the start bit of the next incoming character.

Bit 2—Multiprocessor Mode (MP): Selects a multiprocessor format. When a multiprocessor format is selected, parity settings made by the PE and O/E bits are ignored. The MP bit setting is valid only in asynchronous mode. It is ignored in synchronous mode.

For further information on the multiprocessor communication function, see section 13.3.3, Multiprocessor Communication.

Bit 2 MP	Description
0	Multiprocessor function disabled (Initial value)
1	Multiprocessor format selected

Bits 1 and 0—Clock Select 1 and 0 (CKS1/0): These bits select the clock source for the on-chip baud rate generator. Four clock sources are available: ϕ , $\phi/4$, $\phi/16$, and $\phi/64$.

For the relationship between the clock source, bit rate register setting, and baud rate, see section 13.2.8, Bit Rate Register (BRR).

Bit 1 CKS1	Bit 0 CKS0	Description
0	0	ϕ (Initial value)
0	1	$\phi/4$
1	0	$\phi/16$
1	1	$\phi/64$

13.2.6 Serial Control Register (SCR)

SCR register enables or disables the SCI transmitter and receiver, enables or disables serial clock output in asynchronous mode, enables or disables interrupts, and selects the transmit/receive clock source.

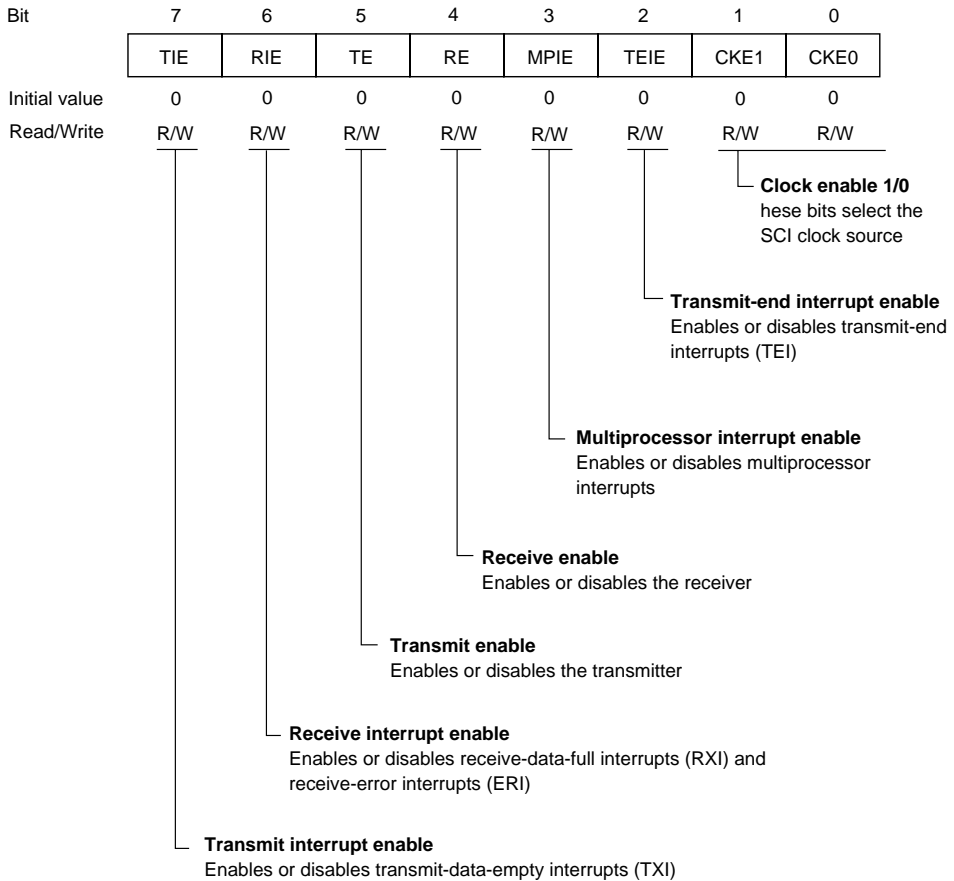

The CPU can always read and write SCR. SCR is initialized to H'00 by a reset and in standby mode.

Bit 7—Transmit Interrupt Enable (TIE): Enables or disables the transmit-data-empty interrupt (TXI) requested when the TDRE flag in SSR is set to 1 due to transfer of serial transmit data from TDR to TSR.

Bit 7

TIE	Description
0	Transmit-data-empty interrupt request (TXI) is disabled* (Initial value)
1	Transmit-data-empty interrupt request (TXI) is enabled

Note: * TXI interrupt requests can be cleared by reading the value 1 from the TDRE flag, then clearing it to 0; or by clearing the TIE bit to 0.

Bit 6—Receive Interrupt Enable (RIE): Enables or disables the receive-data-full interrupt (RXI) requested when the RDRF flag in SSR is set to 1 due to transfer of serial receive data from RSR to RDR; also enables or disables the receive-error interrupt (ERI).

Bit 6

RIE	Description
0	Receive-data-full (RXI) and receive-error (ERI) interrupt requests are disabled* (Initial value)
1	Receive-data-full (RXI) and receive-error (ERI) interrupt requests are enabled

Note: * RXI and ERI interrupt requests can be cleared by reading the value 1 from the RDRF, FER, PER, or ORER flag, then clearing the flag to 0; or by clearing the RIE bit to 0.

Bit 5—Transmit Enable (TE): Enables or disables the start of SCI serial transmitting operations.

Bit 5

TE	Description
0	Transmitting disabled* ¹ (Initial value)
1	Transmitting enabled* ²

Notes: 1. The TDRE flag is fixed at 1 in SSR.
2. In the enabled state, serial transmission starts when the TDRE flag in SSR is cleared to 0 after writing of transmit data into TDR. Select the transmit format in SMR before setting the TE bit to 1.

Bit 4—Receive Enable (RE): Enables or disables the start of SCI serial receiving operations.

Bit 4

RE	Description
0	Receiving disabled* ¹ (Initial value)
1	Receiving enabled* ²

Notes: 1. Clearing the RE bit to 0 does not affect the RDRF, FER, PER, and ORER flags. These flags retain their previous values.
2. In the enabled state, serial receiving starts when a start bit is detected in asynchronous mode, or serial clock input is detected in synchronous mode. Select the receive format in SMR before setting the RE bit to 1.

Bit 3—Multiprocessor Interrupt Enable (MPIE): Enables or disables multiprocessor interrupts. The MPIE bit setting is valid only in asynchronous mode, and only if the MP bit is set to 1 in SMR. The MPIE bit setting is ignored in synchronous mode or when the MP bit is cleared to 0.

Bit 3

MPIE	Description
0	Multiprocessor interrupts are disabled (normal receive operation) (Initial value) [Clearing conditions] <ul style="list-style-type: none">• The MPIE bit is cleared to 0• MPB = 1 in received data
1	Multiprocessor interrupts are enabled* Receive-data-full interrupts (RXI), receive-error interrupts (ERI), and setting of the RDRF, FER, and ORER status flags in SSR are disabled until data with the multiprocessor bit set to 1 is received.

Note: * The SCI does not transfer receive data from RSR to RDR, does not detect receive errors, and does not set the RDRF, FER, and ORER flags in SSR. When it receives data in which MPB = 1, the SCI sets the MPB bit to 1 in SSR, automatically clears the MPIE bit to 0, enables RXI and ERI interrupts (if the TIE and RIE bits in SCR are set to 1), and allows the FER and ORER flags to be set.

Bit 2—Transmit-End interrupt Enable (TEIE): Enables or disables the transmit-end interrupt (TEI) requested if TDR does not contain valid transmit data when the MSB is transmitted.

Bit 2

TEIE	Description
0	Transmit-end interrupt requests (TEI) are disabled* (Initial value)
1	Transmit-end interrupt requests (TEI) are enabled*

Note: * TEI interrupt requests can be cleared by reading the value 1 from the TDRE flag in SSR, then clearing the TDRE flag to 0, thereby also clearing the TEND flag to 0; or by clearing the TEIE bit to 0.

Bits 1 and 0—Clock Enable 1 and 0 (CKE1/0): The function of these bits differs for the normal serial communication interface and for the smart card interface. Their function is switched with the SMIF bit in SCMR.

For serial communication interface (SMIF bit in SCMR cleared to 0): These bits select the SCI clock source and enable or disable clock output from the SCK pin. Depending on the settings of CKE1 and CKE0, the SCK pin can be used for generic input/output, serial clock output, or serial clock input.

The CKE0 setting is valid only in asynchronous mode, and only when the SCI is internally clocked (CKE1 = 0). The CKE0 setting is ignored in synchronous mode, or when an external clock source is selected (CKE1 = 1). Select the SCI operating mode in SMR before setting the CKE1 and CKE0 bits. For further details on selection of the SCI clock source, see table 13.9 in section 13.3, Operation.

Bit 1 Bit 0

CKE1 CKE0 Description

0	0	Asynchronous mode	Internal clock, SCK pin available for generic input/output* ¹
		Synchronous mode	Internal clock, SCK pin used for serial clock output* ¹
0	1	Asynchronous mode	Internal clock, SCK pin used for clock output* ²
		Synchronous mode	Internal clock, SCK pin used for serial clock output
1	0	Asynchronous mode	External clock, SCK pin used for clock input* ³
		Synchronous mode	External clock, SCK pin used for serial clock input
1	1	Asynchronous mode	External clock, SCK pin used for clock input* ³
		Synchronous mode	External clock, SCK pin used for serial clock input

Notes: 1. Initial value

2. The output clock frequency is the same as the bit rate.

3. The input clock frequency is 16 times the bit rate.

For smart card interface (SMIF bit in SCMR set to 1): These bits, together with the GM bit in SMR, determine whether the SCK pin is used for generic input/output or as the serial clock output pin.

SMR GM	Bit 1 CKE1	Bit 0 CKE0	Description
0	0	0	SCK pin available for generic input/output (Initial value)
0	0	1	SCK pin used for clock output
1	0	0	SCK pin output fixed low
1	0	1	SCK pin used for clock output
1	1	0	SCK pin output fixed high
1	1	1	SCK pin used for clock output

13.2.7 Serial Status Register (SSR)

SSR is an 8-bit register containing multiprocessor bit values, and status flags that indicate the operating status of the SCI.

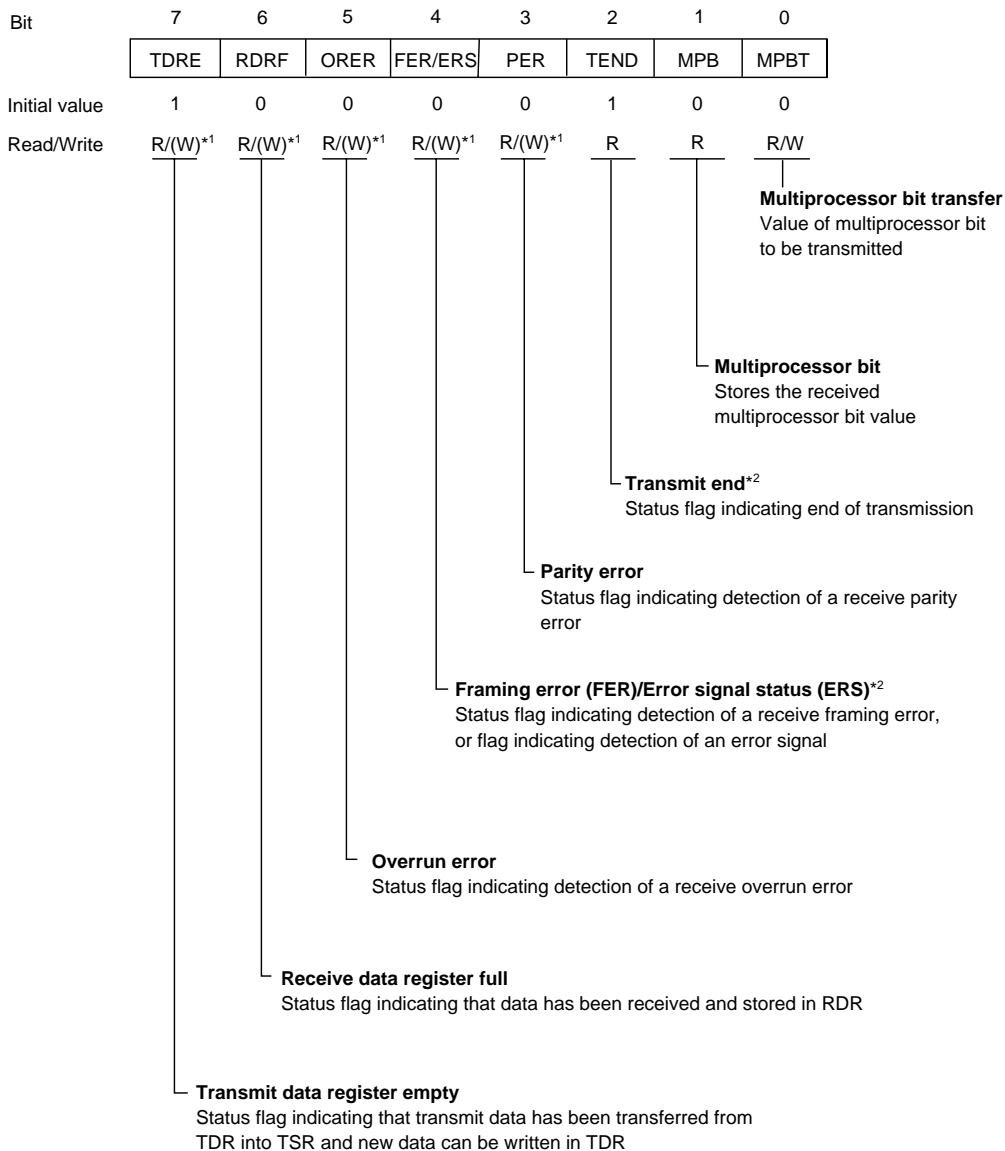

Notes: *1. Only 0 can be written, to clear the flag.

*2. Function differs between the normal serial communication interface and the smart card interface.

The CPU can always read and write SSR, but cannot write 1 in the TDRE, RDRF, ORER, PER, and FER flags. These flags can be cleared to 0 only if they have first been read while set to 1. The TEND and MPB flags are read-only bits that cannot be written.

SSR is initialized to H'84 by a reset and in standby mode.

Bit 7—Transmit Data Register Empty (TDRE): Indicates that the SCI has loaded transmit data from TDR into TSR and the next serial data can be written in TDR.

Bit 7 TDRE	Description
0	TDR contains valid transmit data [Clearing conditions] <ul style="list-style-type: none"> • Read TDRE when TDRE = 1, then write 0 in TDRE • The DMAC writes data in TDR
1	TDR does not contain valid transmit data (Initial value) [Setting conditions] <ul style="list-style-type: none"> • The chip is reset or enters standby mode • The TE bit in SCR is cleared to 0 • TDR contents are loaded into TSR, so new data can be written in TDR

Bit 6—Receive Data Register Full (RDRF): Indicates that RDR contains new receive data.

Bit 6 RDRF	Description
0	RDR does not contain new receive data (Initial value) [Clearing conditions] <ul style="list-style-type: none"> • The chip is reset or enters standby mode • Read RDRF when RDRF = 1, then write 0 in RDRF • The DMAC reads data from RDR
1	RDR contains new receive data [Setting condition] Serial data is received normally and transferred from RSR to RDR

Note: The RDR contents and the RDRF flag are not affected by detection of receive errors or by clearing of the RE bit to 0 in SCR. They retain their previous values. If the RDRF flag is still set to 1 when reception of the next data ends, an overrun error will occur and the receive data will be lost.

Bit 5—Overrun Error (ORER): Indicates that data reception ended abnormally due to an overrun error.

Bit 5 ORER	Description
0	Receiving is in progress or has ended normally* ¹ (Initial value) [Clearing conditions] <ul style="list-style-type: none"> The chip is reset or enters standby mode Read ORER when ORER = 1, then write 0 in ORER
1	A receive overrun error occurred* ² [Setting condition] Reception of the next serial data ends when RDRF = 1

- Notes:
1. Clearing the RE bit to 0 in SCR does not affect the ORER flag, which retains its previous value.
 2. RDR continues to hold the receive data prior to the overrun error, so subsequent receive data is lost. Serial receiving cannot continue while the ORER flag is set to 1. In synchronous mode, serial transmitting is also disabled.

Bit 4—Framing Error (FER)/Error Signal Status (ERS): The function of this bit differs for the normal serial communication interface and for the smart card interface. Its function is switched with the SMIF bit in SCMR.

For serial communication interface (SMIF bit in SCMR cleared to 0): Indicates that data reception ended abnormally due to a framing error in asynchronous mode.

Bit 4 FER	Description
0	Receiving is in progress or has ended normally* ¹ (Initial value) [Clearing conditions] <ul style="list-style-type: none"> The chip is reset or enters standby mode Read FER when FER = 1, then write 0 in FER
1	A receive framing error occurred [Setting condition] The stop bit at the end of the receive data is checked and found to be 0* ²

- Notes:
1. Clearing the RE bit to 0 in SCR does not affect the FER flag, which retains its previous value.
 2. When the stop bit length is 2 bits, only the first bit is checked. The second stop bit is not checked. When a framing error occurs the SCI transfers the receive data into RDR but does not set the RDRF flag. Serial receiving cannot continue while the FER flag is set to 1. In synchronous mode, serial transmitting is also disabled.

For smart card interface (SMIF bit in SCMR set to 1): Indicates the status of the error signal sent back from the receiving side during transmission. Framing errors are not detected in smart card interface mode.

Bit 4 ERS	Description
0	Normal reception, no error signal* (Initial value) [Clearing conditions] <ul style="list-style-type: none"> The chip is reset or enters standby mode Read ERS when ERS = 1, then write 0 in ERS
1	An error signal has been sent from the receiving side indicating detection of a parity error [Setting condition] The error signal is low when sampled

Note: * Clearing the TE bit to 0 in SCR does not affect the ERS flag, which retains its previous value.

Bit 3—Parity Error (PER): Indicates that data reception ended abnormally due to a parity error in asynchronous mode.

Bit 3 PER	Description
0	Receiving is in progress or has ended normally* ¹ (Initial value) [Clearing conditions] <ul style="list-style-type: none"> The chip is reset or enters standby mode Read PER when PER = 1, then write 0 in PER
1	A receive parity error occurred* ² [Setting condition] The number of 1s in receive data, including the parity bit, does not match the even or odd parity setting of O/E in SMR

Notes: 1. Clearing the RE bit to 0 in SCR does not affect the PER flag, which retains its previous value.
2. When a parity error occurs the SCI transfers the receive data into RDR but does not set the RDRF flag. Serial receiving cannot continue while the PER flag is set to 1. In synchronous mode, serial transmitting is also disabled.

Bit 2—Transmit End (TEND): The function of this bit differs for the normal serial communication interface and for the smart card interface. Its function is switched with the SMIF bit in SCMR.

For serial communication interface (SMIF bit in SCMR cleared to 0): Indicates that when the last bit of a serial character was transmitted TDR did not contain valid transmit data, so transmission has ended. The TEND flag is a read-only bit and cannot be written.

Bit 2

TEND	Description
0	Transmission is in progress [Clearing conditions] <ul style="list-style-type: none"> • Read TDRE when TDRE = 1, then write 0 in TDRE • The DMAC writes data in TDR
1	End of transmission (Initial value) [Setting conditions] <ul style="list-style-type: none"> • The chip is reset or enters standby mode • The TE bit in SCR is cleared to 0 • TDRE is 1 when the last bit of a 1-byte serial transmit character is transmitted

For smart card interface (SMIF bit in SCMR set to 1): Indicates that when the last bit of a serial character was transmitted TDR did not contain valid transmit data, so transmission has ended. The TEND flag is a read-only bit and cannot be written.

Bit 2

TEND	Description
0	Transmission is in progress [Clearing conditions] <ul style="list-style-type: none"> • Read TDRE when TDRE = 1, then write 0 in TDRE • The DMAC writes data in TDR
1	End of transmission (Initial value) [Setting conditions] <ul style="list-style-type: none"> • The chip is reset or enters standby mode • The TE bit is cleared to 0 in SCR and the FER/ERS bit is also cleared to 0 • TDRE is 1 and FER/ERS is 0 (normal transmission) 2.5 etu (when GM = 0) or 1.0 etu (when GM = 1) after a 1-byte serial character is transmitted

Note: etu: Elementary time unit (time required to transmit one bit)

Bit 1—Multiprocessor bit (MPB): Stores the value of the multiprocessor bit in the receive data when a multiprocessor format is used in asynchronous mode. MPB is a read-only bit, and cannot be written.

Bit 1 MPB	Description
0	Multiprocessor bit value in receive data is 0* (Initial value)
1	Multiprocessor bit value in receive data is 1

Note: * If the RE bit in SCR is cleared to 0 when a multiprocessor format is selected, MPB retains its previous value.

Bit 0—Multiprocessor Bit Transfer (MPBT): Stores the value of the multiprocessor bit added to transmit data when a multiprocessor format is selected for transmitting in asynchronous mode.

The MPBT bit setting is ignored in synchronous mode, when a multiprocessor format is not selected, or when the SCI cannot transmit.

Bit 0 MPBT	Description
0	Multiprocessor bit value in transmit data is 0 (Initial value)
1	Multiprocessor bit value in transmit data is 1

13.2.8 Bit Rate Register (BRR)

BRR is an 8-bit register that, together with the CKS1 and CKS0 bits in SMR that select the baud rate generator clock source, determines the serial communication bit rate.

Bit	7	6	5	4	3	2	1	0
Initial value	1	1	1	1	1	1	1	1
Read/Write	R/W	R/W	R/W	R/W	R/W	R/W	R/W	R/W

The CPU can always read and write BRR. BRR is initialized to H'FF by a reset and in standby mode. Each SCI channel has independent baud rate generator control, so different values can be set in the three channels.

Table 13.3 shows examples of BRR settings in asynchronous mode. Table 13.4 shows examples of BRR settings in synchronous mode.

Table 13.3 Examples of Bit Rates and BRR Settings in Asynchronous Mode

Bit Rate (bit/s)	ϕ (MHz)											
	2			2.097152			2.4576			3		
	n	N	Error (%)	n	N	Error (%)	n	N	Error (%)	n	N	Error (%)
110	1	141	0.03	1	148	-0.04	1	174	-0.26	1	212	0.03
150	1	103	0.16	1	108	0.21	1	127	0.00	1	155	0.16
300	0	207	0.16	0	217	0.21	0	255	0.00	1	77	0.16
600	0	103	0.16	0	108	0.21	0	127	0.00	0	155	0.16
1200	0	51	0.16	0	54	-0.70	0	63	0.00	0	77	0.16
2400	0	25	0.16	0	26	1.14	0	31	0.00	0	38	0.16
4800	0	12	0.16	0	13	-2.48	0	15	0.00	0	19	-2.34
9600	0	6	-6.99	0	6	-2.48	0	7	0.00	0	9	-2.34
19200	0	2	8.51	0	2	13.78	0	3	0.00	0	4	-2.34
31250	0	1	0.00	0	1	4.86	0	1	22.88	0	2	0.00
38400	0	1	-18.62	0	1	-14.67	0	1	0.00	—	—	—

Bit Rate (bit/s)	ϕ (MHz)											
	3.6864			4			4.9152			5		
	n	N	Error (%)	n	N	Error (%)	n	N	Error (%)	n	N	Error (%)
110	2	64	0.07	2	70	0.03	2	86	0.31	2	88	-0.25
150	1	191	0.00	1	207	0.16	1	255	0.00	2	64	0.16
300	1	95	0.00	1	103	0.16	1	127	0.00	1	129	0.16
600	0	191	0.00	0	207	0.16	0	255	0.00	1	64	0.16
1200	0	95	0.00	0	103	0.16	0	127	0.00	0	129	0.16
2400	0	47	0.00	0	51	0.16	0	63	0.00	0	64	0.16
4800	0	23	0.00	0	25	0.16	0	31	0.00	0	32	-1.36
9600	0	11	0.00	0	12	0.16	0	15	0.00	0	15	1.73
19200	0	5	0.00	0	6	-6.99	0	7	0.00	0	7	1.73
31250	—	—	—	0	3	0.00	0	4	-1.70	0	4	0.00
38400	0	2	0.00	0	2	8.51	0	3	0.00	0	3	1.73

Bit Rate (bit/s)	ϕ (MHz)											
	6			6.144			7.3728			8		
	n	N	Error (%)	n	N	Error (%)	n	N	Error (%)	n	N	Error (%)
110	2	106	-0.44	2	108	0.08	2	130	-0.07	2	141	0.03
150	2	77	0.16	2	79	0.00	2	95	0.00	2	103	0.16
300	1	155	0.16	1	159	0.00	1	191	0.00	1	207	0.16
600	1	77	0.16	1	79	0.00	1	95	0.00	1	103	0.16
1200	0	155	0.16	0	159	0.00	0	191	0.00	0	207	0.16
2400	0	77	0.16	0	79	0.00	0	95	0.00	0	103	0.16
4800	0	38	0.16	0	39	0.00	0	47	0.00	0	51	0.16
9600	0	19	-2.34	0	19	0.00	0	23	0.00	0	25	0.16
19200	0	9	-2.34	0	9	0.00	0	11	0.00	0	12	0.16
31250	0	5	0.00	0	5	2.40	0	6	5.33	0	7	0.00
38400	0	4	-2.34	0	4	0.00	0	5	0.00	0	6	-6.99

Bit Rate (bit/s)	ϕ (MHz)											
	9.8304			10			12			12.288		
	n	N	Error (%)	n	N	Error (%)	n	N	Error (%)	n	N	Error (%)
110	2	174	-0.26	2	177	-0.25	2	212	0.03	2	217	0.08
150	2	127	0.00	2	129	0.16	2	155	0.16	2	159	0.00
300	1	255	0.00	2	64	0.16	2	77	0.16	2	79	0.00
600	1	127	0.00	1	129	0.16	1	155	0.16	1	159	0.00
1200	0	255	0.00	1	64	0.16	1	77	0.16	1	79	0.00
2400	0	127	0.00	0	129	0.16	0	155	0.16	0	159	0.00
4800	0	63	0.00	0	64	0.16	0	77	0.16	0	79	0.00
9600	0	31	0.00	0	32	-1.36	0	38	0.16	0	39	0.00
19200	0	15	0.00	0	15	1.73	0	19	-2.34	0	19	0.00
31250	0	9	-1.70	0	9	0.00	0	11	0.00	0	11	2.40
38400	0	7	0.00	0	7	1.73	0	9	-2.34	0	9	0.00

Bit Rate (bit/s)	ϕ (MHz)																	
	13			14			14.7456			16			18			20		
	n	N	Error (%)	n	N	Error (%)	n	N	Error (%)	n	N	Error (%)	n	N	Error (%)	n	N	Error (%)
110	2	230	-0.08	2	248	-0.17	3	64	0.70	3	70	0.03	3	79	-0.12	3	88	-0.25
150	2	168	0.16	2	181	0.16	2	191	0.00	2	207	0.16	2	233	0.16	3	64	0.16
300	2	84	-0.43	2	90	0.16	2	95	0.00	2	103	0.16	2	116	0.16	2	129	0.16
600	1	168	0.16	1	181	0.16	1	191	0.00	1	207	0.16	1	233	0.16	2	64	0.16
1200	1	84	-0.43	1	90	0.16	1	95	0.00	1	103	0.16	1	116	0.16	1	129	0.16
2400	0	168	0.16	0	181	0.16	0	191	0.00	0	207	0.16	0	233	0.16	1	64	0.16
4800	0	84	-0.43	0	90	0.16	0	95	0.00	0	103	0.16	0	116	0.16	0	129	0.16
9600	0	41	0.76	0	45	-0.93	0	47	0.00	0	51	0.16	0	58	-0.69	0	64	0.16
19200	0	20	0.76	0	22	-0.93	0	23	0.00	0	25	0.16	0	28	1.02	0	32	-1.36
31250	0	12	0.00	0	13	0.00	0	14	-1.70	0	15	0.00	0	17	0.00	0	19	0.00
38400	0	10	-3.82	0	10	3.57	0	11	0.00	0	12	0.16	0	14	-2.34	0	15	1.73

Table 13.4 Examples of Bit Rates and BRR Settings in Synchronous Mode

Bit Rate (bit/s)	ϕ (MHz)															
	2		4		8		10		13		16		18		20	
	n	N	n	N	n	N	n	N	n	N	n	N	n	N	n	N
110	3	70	—	—	—	—	—	—	—	—	—	—	—	—	—	—
250	2	124	2	249	3	124	—	—	3	202	3	249	—	—	—	—
500	1	249	2	124	2	249	—	—	3	101	3	124	3	140	3	155
1k	1	124	1	249	2	124	—	—	2	202	2	249	3	69	3	77
2.5k	0	199	1	99	1	199	1	249	2	80	2	99	2	112	2	124
5k	0	99	0	199	1	99	1	124	1	162	1	199	1	224	1	249
10k	0	49	0	99	0	199	0	249	1	80	1	99	1	112	1	124
25k	0	19	0	39	0	79	0	99	0	129	0	159	0	179	0	199
50k	0	9	0	19	0	39	0	49	0	64	0	79	0	89	0	99
100k	0	4	0	9	0	19	0	24	—	—	0	39	0	44	0	49
250k	0	1	0	3	0	7	0	9	0	12	0	15	0	17	0	19
500k	0	0*	0	1	0	3	0	4	—	—	0	7	0	8	0	9
1M			0	0*	0	1	—	—	—	—	0	3	0	4	0	4
2M					0	0*	—	—	—	—	0	1	—	—	—	—
2.5M					—	—	0	0*	—	—	—	—	—	—	—	—
4M											0	0*	—	—	—	—

Note: Settings with an error of 1% or less are recommended.

Legend

Blank : No setting available

— : Setting possible, but error occurs

* : Continuous transmission/reception not possible

The BRR setting is calculated as follows:

Asynchronous mode:

$$N = \frac{\phi}{64 \times 2^{2n-1} \times B} \times 10^6 - 1$$

Synchronous mode:

$$N = \frac{\phi}{8 \times 2^{2n-1} \times B} \times 10^6 - 1$$

B: Bit rate (bit/s)

N: BRR setting for baud rate generator ($0 \leq N \leq 255$)

ϕ : System clock frequency (MHz)

n: Baud rate generator clock source ($n = 0, 1, 2, 3$)

(For the clock sources and values of n, see the following table.)

n	Clock Source	SMR Settings	
		CKS1	CKS0
0	ϕ	0	0
1	$\phi/4$	0	1
2	$\phi/16$	1	0
3	$\phi/64$	1	1

The bit rate error in asynchronous mode is calculated as follows:

$$\text{Error (\%)} = \left\{ \frac{\phi \times 10^6}{(N + 1) \times B \times 64 \times 2^{2n-1}} - 1 \right\} \times 100$$

Table 13.5 shows the maximum bit rates in asynchronous mode for various system clock frequencies. Table 13.6 and 13.7 shows the maximum bit rates with external clock input.

Table 13.5 Maximum Bit Rates for Various Frequencies (Asynchronous Mode)

ϕ (MHz)	Maximum Bit Rate (bit/s)	Settings	
		n	N
2	62500	0	0
2.097152	65536	0	0
2.4576	76800	0	0
3	93750	0	0
3.6864	115200	0	0
4	125000	0	0
4.9152	153600	0	0
5	156250	0	0
6	187500	0	0
6.144	192000	0	0
7.3728	230400	0	0
8	250000	0	0
9.8304	307200	0	0
10	312500	0	0
12	375000	0	0
12.288	384000	0	0
14	437500	0	0
14.7456	460800	0	0
16	500000	0	0
17.2032	537600	0	0
18	562500	0	0
20	625000	0	0

Table 13.6 Maximum Bit Rates with External Clock Input (Asynchronous Mode)

ϕ (MHz)	External Input Clock (MHz)	Maximum Bit Rate (bit/s)
2	0.5000	31250
2.097152	0.5243	32768
2.4576	0.6144	38400
3	0.7500	46875
3.6864	0.9216	57600
4	1.0000	62500
4.9152	1.2288	76800
5	1.2500	78125
6	1.5000	93750
6.144	1.5360	96000
7.3728	1.8432	115200
8	2.0000	125000
9.8304	2.4576	153600
10	2.5000	156250
12	3.0000	187500
12.288	3.0720	192000
14	3.5000	218750
14.7456	3.6864	230400
16	4.0000	250000
17.2032	4.3008	268800
18	4.5000	281250
20	5.0000	312500

Table 13.7 Maximum Bit Rates with External Clock Input (Synchronous Mode)

ϕ (MHz)	External Input Clock (MHz)	Maximum Bit Rate (bit/s)
2	0.3333	333333.3
4	0.6667	666666.7
6	1.0000	1000000.0
8	1.3333	1333333.3
10	1.6667	1666666.7
12	2.0000	2000000.0
14	2.3333	2333333.3
16	2.6667	2666666.7
18	3.0000	3000000.0
20	3.3333	3333333.3

13.3 Operation

13.3.1 Overview

The SCI can carry out serial communication in two modes: asynchronous mode in which synchronization is achieved character by character, and synchronous mode in which synchronization is achieved with clock pulses. A smart card interface is also supported as a serial communication function for an IC card interface.

Selection of asynchronous or synchronous mode and the transmission format for the normal serial communication interface is made in SMR, as shown in table 13.8. The SCI clock source is selected by the C/\bar{A} bit in SMR and the CKE1 and CKE0 bits in SCR, as shown in table 13.9.

For details of the procedures for switching between LSB-first and MSB-first mode and inverting the data logic level, see section 14.2.1, Smart Card Mode Register (SCMR).

For selection of the smart card interface format, see section 14.3.3, Data Format.

Asynchronous Mode

- Data length is selectable: 7 or 8 bits
- Parity and multiprocessor bits are selectable, and so is the stop bit length (1 or 2 bits). These selections determine the communication format and character length.
- In receiving, it is possible to detect framing errors, parity errors, overrun errors, and the break state.
- An internal or external clock can be selected as the SCI clock source.
 - When an internal clock is selected, the SCI operates using the on-chip baud rate generator, and can output a serial clock signal with a frequency matching the bit rate.
 - When an external clock is selected, the external clock input must have a frequency 16 times the bit rate. (The on-chip baud rate generator is not used.)

Synchronous Mode

- The communication format has a fixed 8-bit data length.
- In receiving, it is possible to detect overrun errors.
- An internal or external clock can be selected as the SCI clock source.
 - When an internal clock is selected, the SCI operates using the on-chip baud rate generator, and can output a serial clock signal to external devices.
 - When an external clock is selected, the SCI operates on the input serial clock. The on-chip baud rate generator is not used.

Smart Card Interface

- One frame consists of 8-bit data and a parity bit.
- In transmitting, a guard time of at least two elementary time units (2 etu) is provided between the end of the parity bit and the start of the next frame. (An elementary time unit is the time required to transmit one bit.)
- In receiving, if a parity error is detected, a low error signal level is output for 1 etu, beginning 10.5 etu after the start bit.
- In transmitting, if an error signal is received, the same data is automatically transmitted again after at least 2 etu.
- Only asynchronous communication is supported. There is no synchronous communication function.

For details of smart card interface operation, see section 14, Smart Card Interface.

Table 13.8 SMR Settings and Serial Communication Formats

SMR Settings						SCI Communication Format			
Bit 7 C/ \bar{A}	Bit 6 CHR	Bit 2 MP	Bit 5 PE	Bit 3 STOP	Mode	Data Length	Multi- processor Bit	Parity Bit	Stop Bit Length
0	0	0	0	0	Asyn- chronous mode	8-bit data	Absent	Absent	1 bit
				1					2 bits
				0					1 bit
				1					2 bits
				0					1 bit
				1					2 bits
	1	0	0	0	7-bit data	Absent	Absent	1 bit	
				1				2 bits	
				0				1 bit	
				1				2 bits	
				0				1 bit	
				1				2 bits	
0	1	—	0	Asyn- chronous mode (multi- processor format)	8-bit data	Present	Absent	1 bit	
			1					2 bits	
			0					1 bit	
			1					2 bits	
			0					1 bit	
			1					2 bits	
1	—	—	—	—	Syn- chronous mode	8-bit data	Absent	None	

Table 13.9 SMR and SCR Settings and SCI Clock Source Selection

SMR Bit 7 C/ \bar{A}	SCR Setting		Mode	SCI Transmit/Receive clock	
	Bit 1 CKE1	Bit 0 CKE0		Clock Source	SCK Pin Function
0	0	0	Asynchronous mode	Internal	SCI does not use the SCK pin
		1			Outputs clock with frequency matching the bit rate
	1	0		External	Inputs clock with frequency 16 times the bit rate
		1			
1	0	0	Synchronous mode	Internal	Outputs the serial clock
		1			
	1	0		External	Inputs the serial clock
		1			

13.3.2 Operation in Asynchronous Mode

In asynchronous mode, each transmitted or received character begins with a start bit and ends with one or two stop bits. Serial communication is synchronized one character at a time.

The transmitting and receiving sections of the SCI are independent, so full-duplex communication is possible. The transmitter and the receiver are both double-buffered, so data can be written and read while transmitting and receiving are in progress, enabling continuous transmitting and receiving.

Figure 13.2 shows the general format of asynchronous serial communication. In asynchronous serial communication the communication line is normally held in the mark (high) state. The SCI monitors the line and starts serial communication when the line goes to the space (low) state, indicating a start bit. One serial character consists of a start bit (low), data (LSB first), parity bit (high or low), and one or two stop bits (high), in that order.

When receiving in asynchronous mode, the SCI synchronizes at the falling edge of the start bit. The SCI samples each data bit on the eighth pulse of a clock with a frequency 16 times the bit rate. Receive data is latched at the center of each bit.

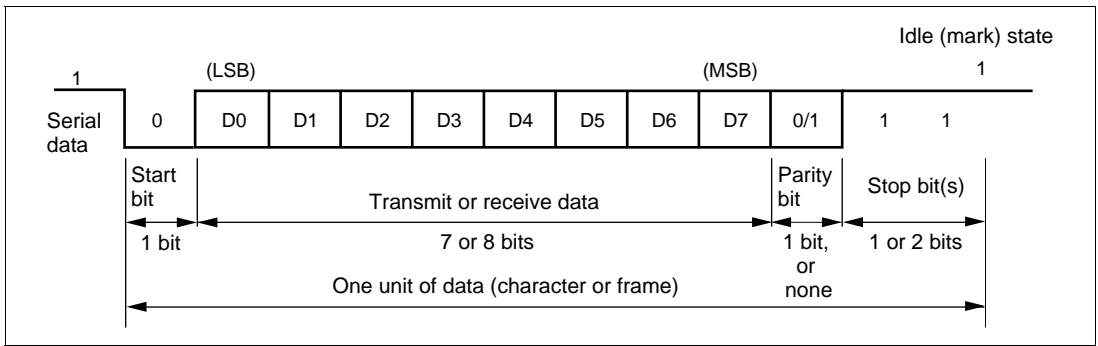

Figure 13.2 Data Format in Asynchronous Communication
(Example: 8-Bit Data with Parity and 2 Stop Bits)

Communication Formats: Table 13.10 shows the 12 communication formats that can be selected in asynchronous mode. The format is selected by settings in SMR.

Table 13.10 Serial Communication Formats (Asynchronous Mode)

SMR Settings				Serial Communication Format and Frame Length													
CHR	PE	MP	STOP	1	2	3	4	5	6	7	8	9	10	11	12		
0	0	0	0	S	8-bit data								STOP				
0	0	0	1	S	8-bit data								STOP	STOP			
0	1	0	0	S	8-bit data								P	STOP			
0	1	0	1	S	8-bit data								P	STOP	STOP		
1	0	0	0	S	7-bit data							STOP					
1	0	0	1	S	7-bit data							STOP	STOP				
1	1	0	0	S	7-bit data							P	STOP				
1	1	0	1	S	7-bit data							P	STOP	STOP			
0	—	1	0	S	8-bit data								MPB	STOP			
0	—	1	1	S	8-bit data								MPB	STOP	STOP		
1	—	1	0	S	7-bit data							MPB	STOP				
1	—	1	1	S	7-bit data							MPB	STOP	STOP			

Legend

- S: Start bit
- STOP: Stop bit
- P: Parity bit
- MPB: Multiprocessor bit

Clock: An internal clock generated by the on-chip baud rate generator or an external clock input from the SCK pin can be selected as the SCI transmit/receive clock. The clock source is selected by the C/\overline{A} bit in SMR and bits CKE1 and CKE0 in SCR. For details of SCI clock source selection, see table 13.9.

When an external clock is input at the SCK pin, it must have a frequency 16 times the desired bit rate.

When the SCI is operated on an internal clock, it can output a clock signal at the SCK pin. The frequency of this output clock is equal to the bit rate. The phase is aligned as shown in figure 13.3 so that the rising edge of the clock occurs at the center of each transmit data bit.

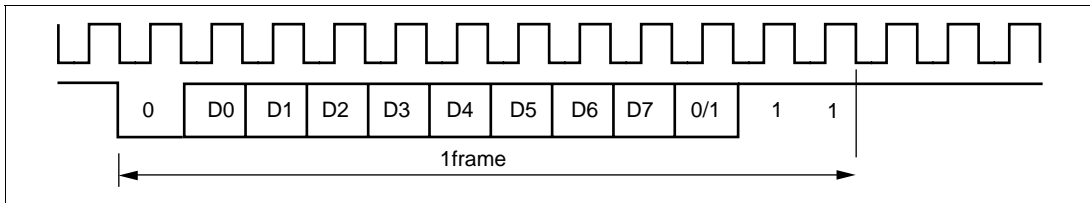

Figure 13.3 Phase Relationship between Output Clock and Serial Data (Asynchronous Mode)

Transmitting and Receiving Data:

- **SCI Initialization (Asynchronous Mode):** Before transmitting or receiving data, clear the TE and RE bits to 0 in SCR, then initialize the SCI as follows.

When changing the communication mode or format, always clear the TE and RE bits to 0 before following the procedure given below. Clearing TE to 0 sets the TDRE flag to 1 and initializes TSR. Clearing RE to 0, however, does not initialize the RDRF, PER, FER, and ORER flags, or RDR, which retain their previous contents.

When an external clock is used the clock should not be stopped during initialization or subsequent operation, since operation will be unreliable in this case.

Figure 13.4 shows a sample flowchart for initializing the SCI.

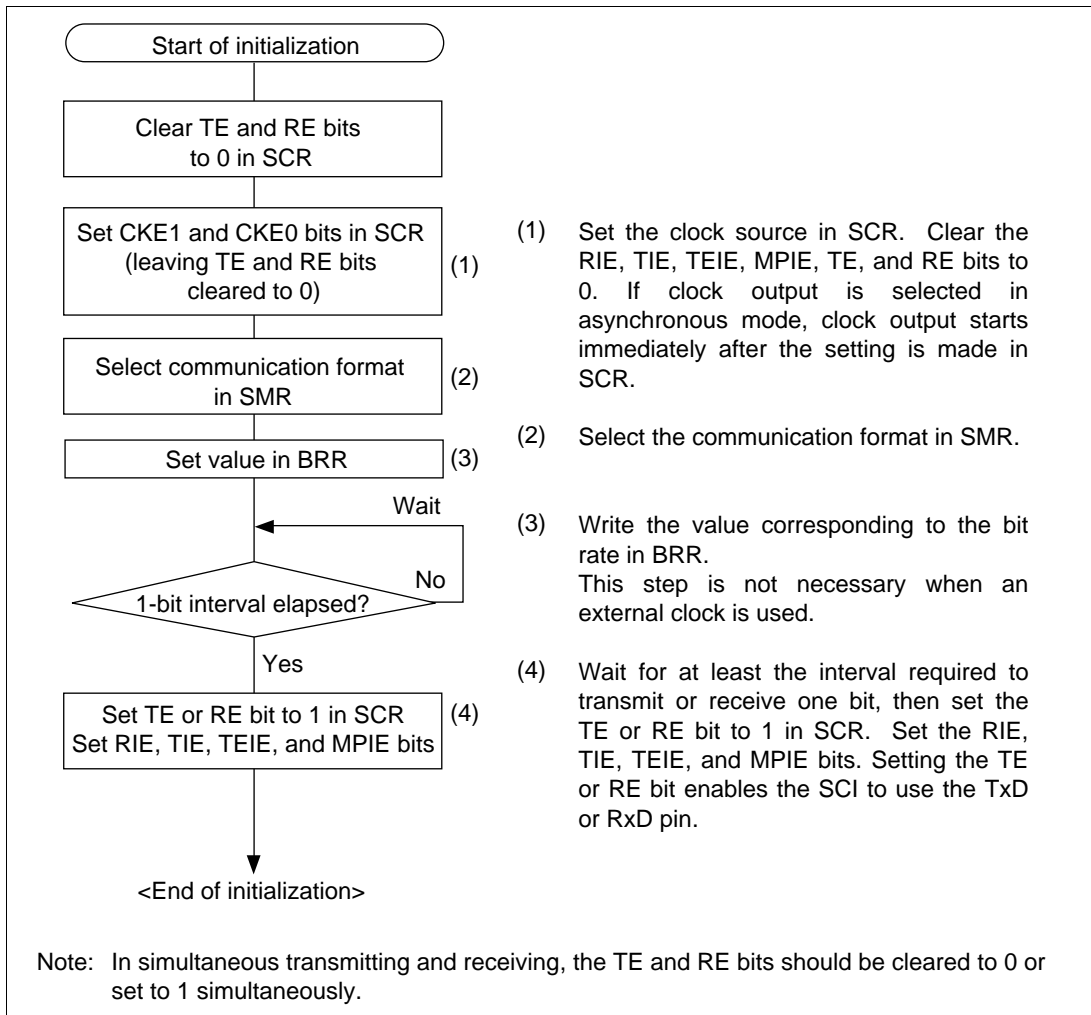

Figure 13.4 Sample Flowchart for SCI Initialization

- Transmitting Serial Data (Asynchronous Mode): Figure 13.5 shows a sample flowchart for transmitting serial data and indicates the procedure to follow.

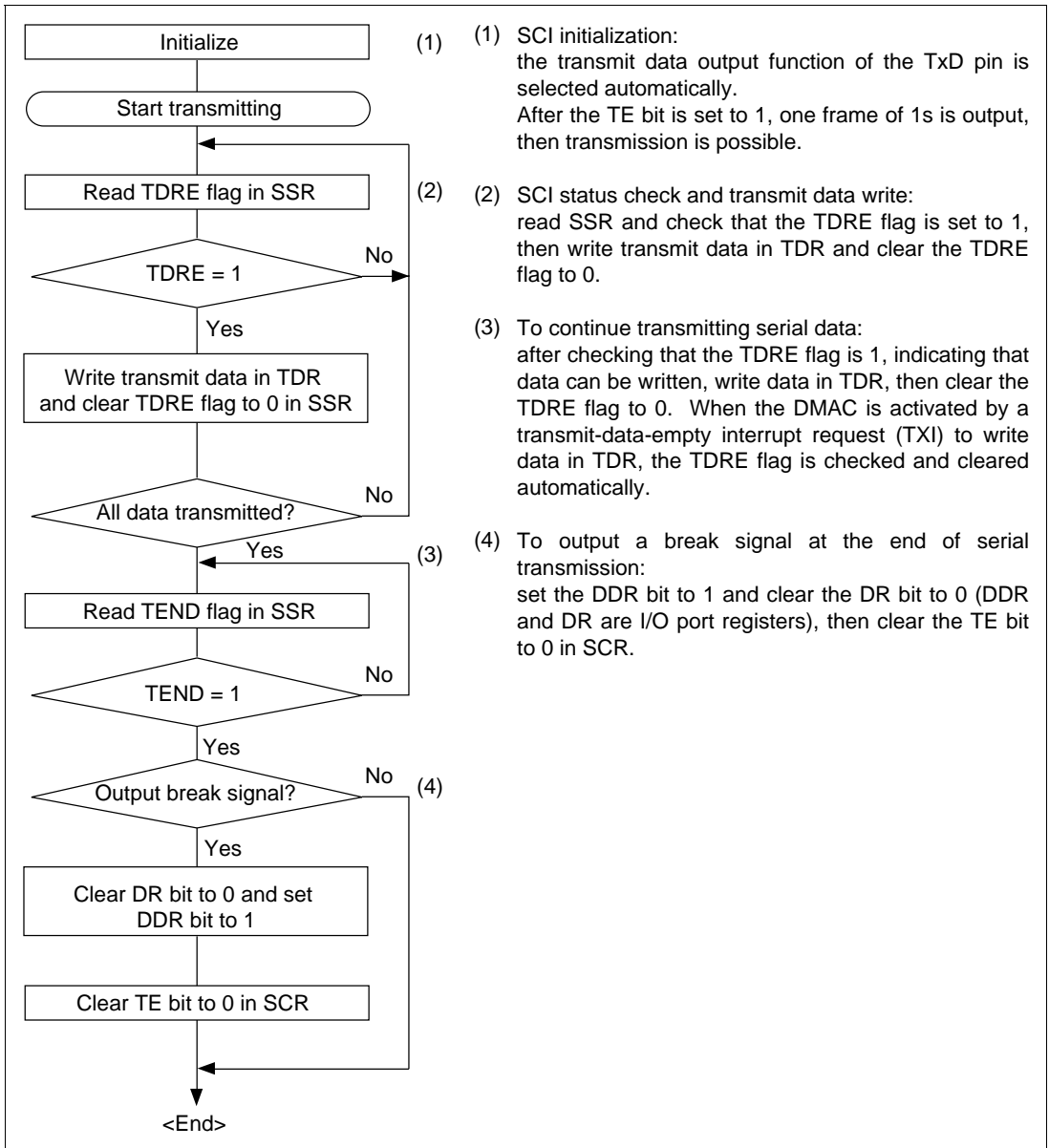

Figure 13.5 Sample Flowchart for Transmitting Serial Data

In transmitting serial data, the SCI operates as follows:

- The SCI monitors the TDRE flag in SSR. When the TDRE flag is cleared to 0, the SCI recognizes that TDR contains new data, and loads this data from TDR into TSR.
- After loading the data from TDR to TSR, the SCI sets the TDRE flag to 1 and starts transmitting. If the TIE bit is set to 1 in SCR, the SCI requests a transmit-data-empty interrupt (TXI) at this time.

Serial transmit data is transmitted in the following order from the TxD pin:

- Start bit: One 0 bit is output.
- Transmit data: 7 or 8 bits are output, LSB first.
- Parity bit or multiprocessor bit: One parity bit (even or odd parity), or one multiprocessor bit is output. Formats in which neither a parity bit nor a multiprocessor bit is output can also be selected.
- Stop bit(s): One or two 1 bits (stop bits) are output.
- Mark state: Output of 1 bits continues until the start bit of the next transmit data.
- The SCI checks the TDRE flag when it outputs the stop bit. If the TDRE flag is 0, the SCI loads new data from TDR into TSR, outputs the stop bit, then begins serial transmission of the next frame. If the TDRE flag is 1, the SCI sets the TEND flag to 1 in SSR, outputs the stop bit, then continues output of 1 bits in the mark state. If the TEIE bit is set to 1 in SCR, a transmit-end interrupt (TEI) is requested at this time

Figure 13.6 shows an example of SCI transmit operation in asynchronous mode.

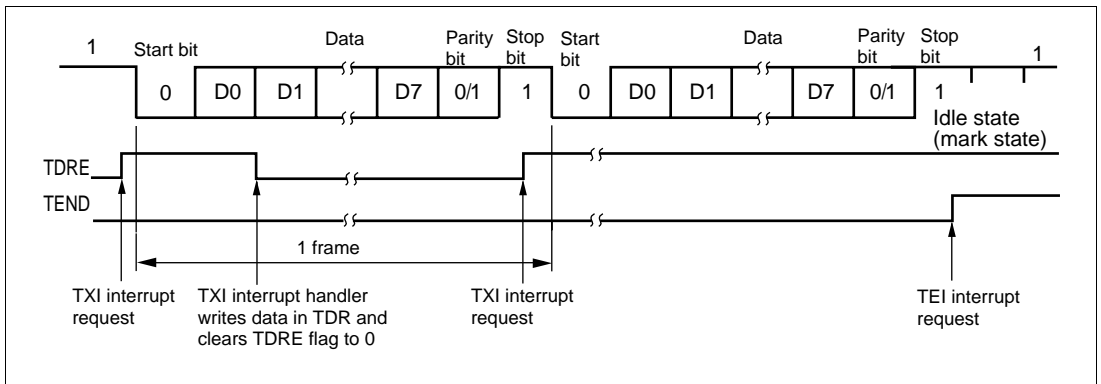

Figure 13.6 Example of SCI Transmit Operation in Asynchronous Mode (8-Bit Data with Parity and One Stop Bit)

- Receiving Serial Data (Asynchronous Mode): Figure 13.7 shows a sample flowchart for receiving serial data and indicates the procedure to follow.

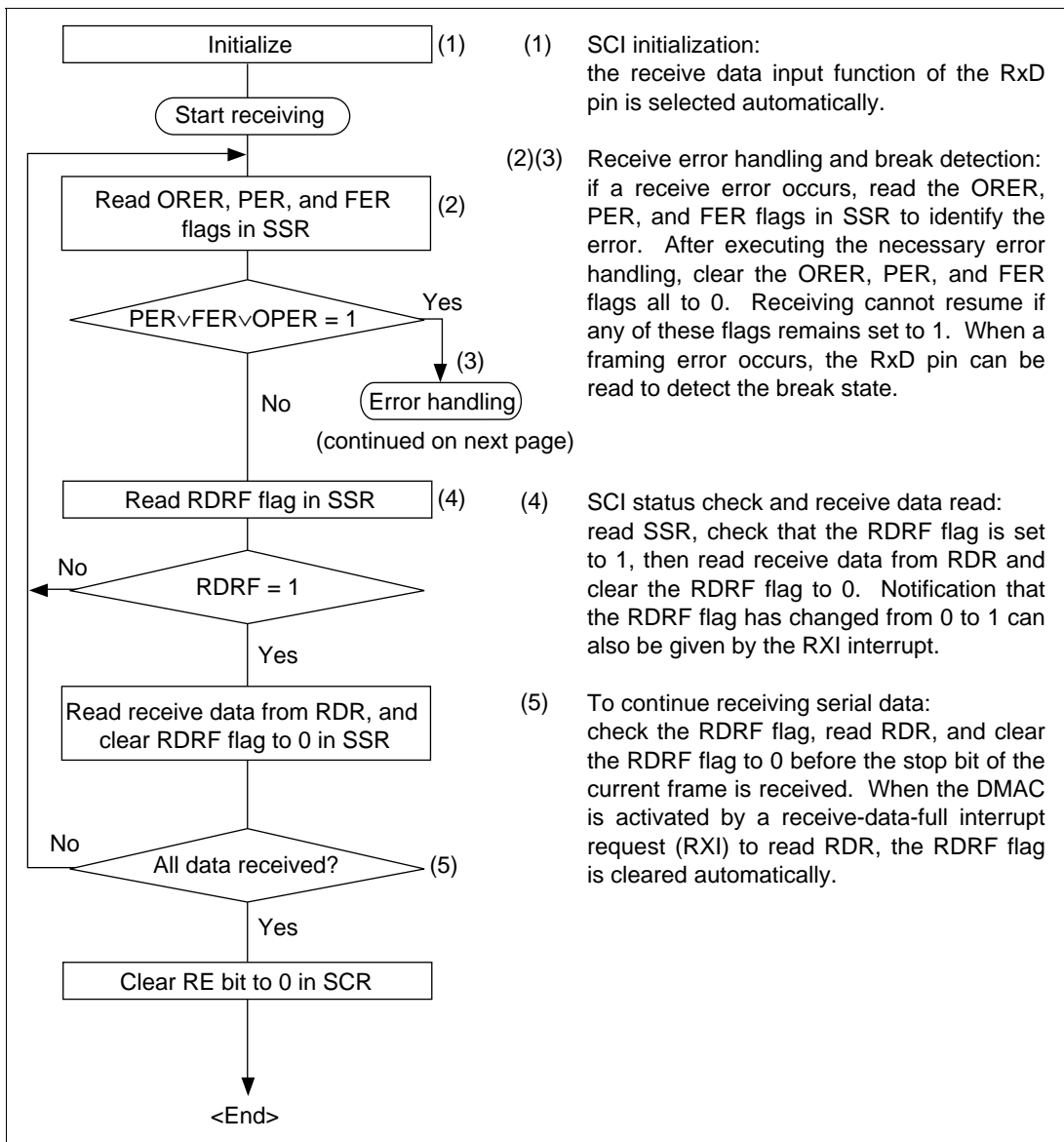

Figure 13.7 Sample Flowchart for Receiving Serial Data

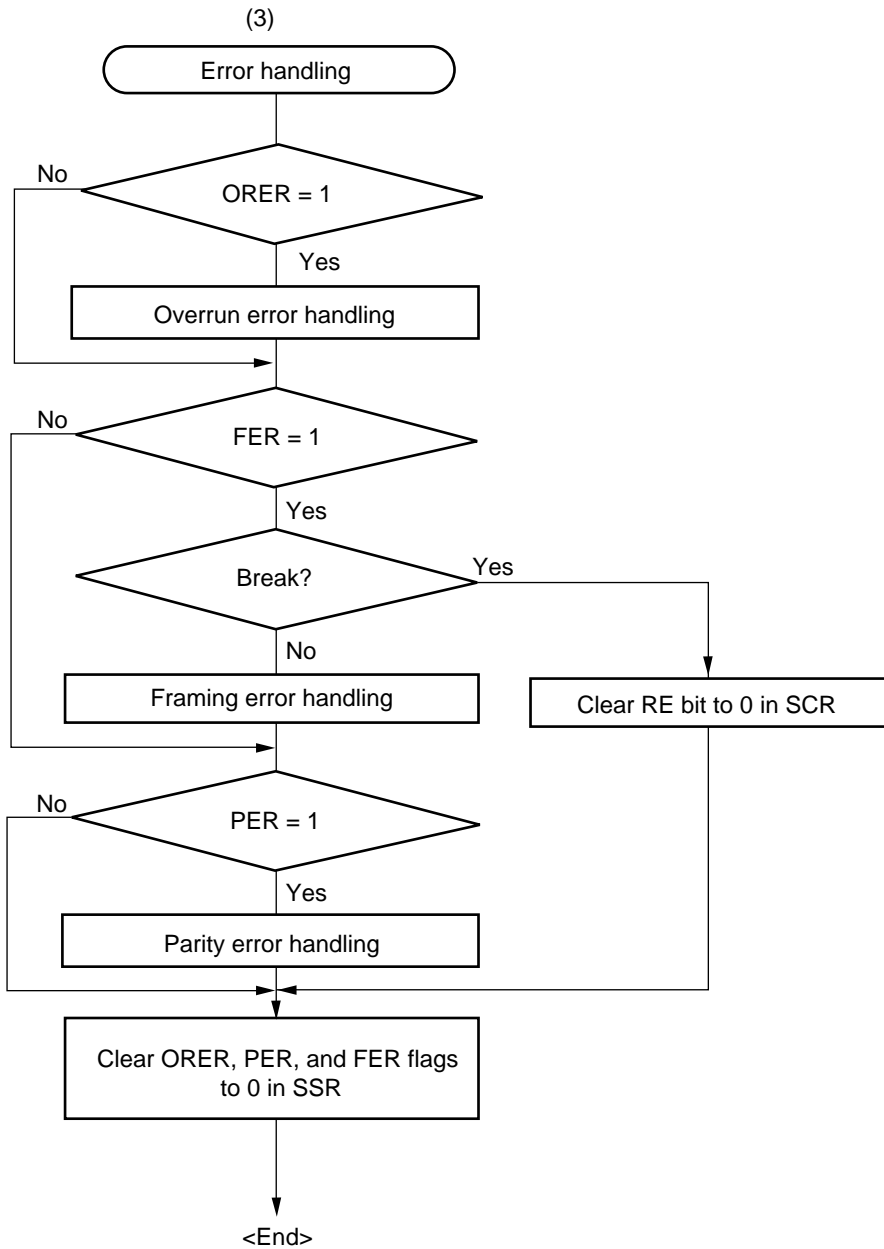

Figure 13.7 Sample Flowchart for Receiving Serial Data (cont)

In receiving, the SCI operates as follows:

- The SCI monitors the communication line. When it detects a start bit (0 bit), the SCI synchronizes internally and starts receiving.
- Receive data is stored in RSR in order from LSB to MSB.
- The parity bit and stop bit are received.

After receiving these bits, the SCI carries out the following checks:

- Parity check: The number of 1s in the receive data must match the even or odd parity setting of in the O/ \bar{E} bit in SMR.
- Stop bit check: The stop bit value must be 1. If there are two stop bits, only the first is checked.
- Status check: The RDRF flag must be 0, indicating that the receive data can be transferred from RSR into RDR.

If these all checks pass, the RDRF flag is set to 1 and the received data is stored in RDR. If one of the checks fails (receive error*), the SCI operates as shown in table 13.11.

Note: * When a receive error occurs, further receiving is disabled. In receiving, the RDRF flag is not set to 1. Be sure to clear the error flags to 0.

- When the RDRF flag is set to 1, if the RIE bit is set to 1 in SCR, a receive-data-full interrupt (RXI) is requested. If the ORER, PER, or FER flag is set to 1 and the RIE bit in SCR is also set to 1, a receive-error interrupt (ERI) is requested.

Table 13.11 Receive Error Conditions

Receive Error	Abbreviation	Condition	Data Transfer
Overrun error	ORER	Receiving of next data ends while RDRF flag is still set to 1 in SSR	Receive data is not transferred from RSR to RDR
Framing error	FER	Stop bit is 0	Receive data is transferred from RSR to RDR
Parity error	PER	Parity of received data differs from even/odd parity setting in SMR	Receive data is transferred from RSR to RDR

Figure 13.8 shows an example of SCI receive operation in asynchronous mode.

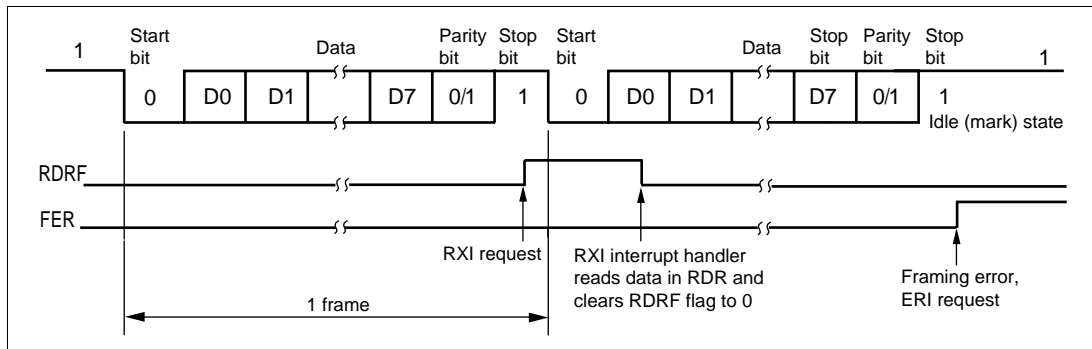

**Figure 13.8 Example of SCI Receive Operation
(8-Bit Data with Parity and One Stop Bit)**

13.3.3 Multiprocessor Communication

The multiprocessor communication function enables several processors to share a single serial communication line. The processors communicate in asynchronous mode using a format with an additional multiprocessor bit (multiprocessor format).

In multiprocessor communication, each receiving processor is addressed by an ID. A serial communication cycle consists of an ID-sending cycle that identifies the receiving processor, and a data-sending cycle. The multiprocessor bit distinguishes ID-sending cycles from data-sending cycles.

The transmitting processor starts by sending the ID of the receiving processor with which it wants to communicate as data with the multiprocessor bit set to 1. Next the transmitting processor sends transmit data with the multiprocessor bit cleared to 0.

Receiving processors skip incoming data until they receive data with the multiprocessor bit set to 1. When they receive data with the multiprocessor bit set to 1, receiving processors compare the data with their IDs. Processors with IDs not matching the received data skip further incoming data until they again receive data with the multiprocessor bit set to 1. Multiple processors can send and receive data in this way.

Figure 13.9 shows an example of communication among different processors using a multiprocessor format.

Communication Formats: Four formats are available. Parity bit settings are ignored when a multiprocessor format is selected. For details see table 13.10.

Clock: See the description of asynchronous mode.

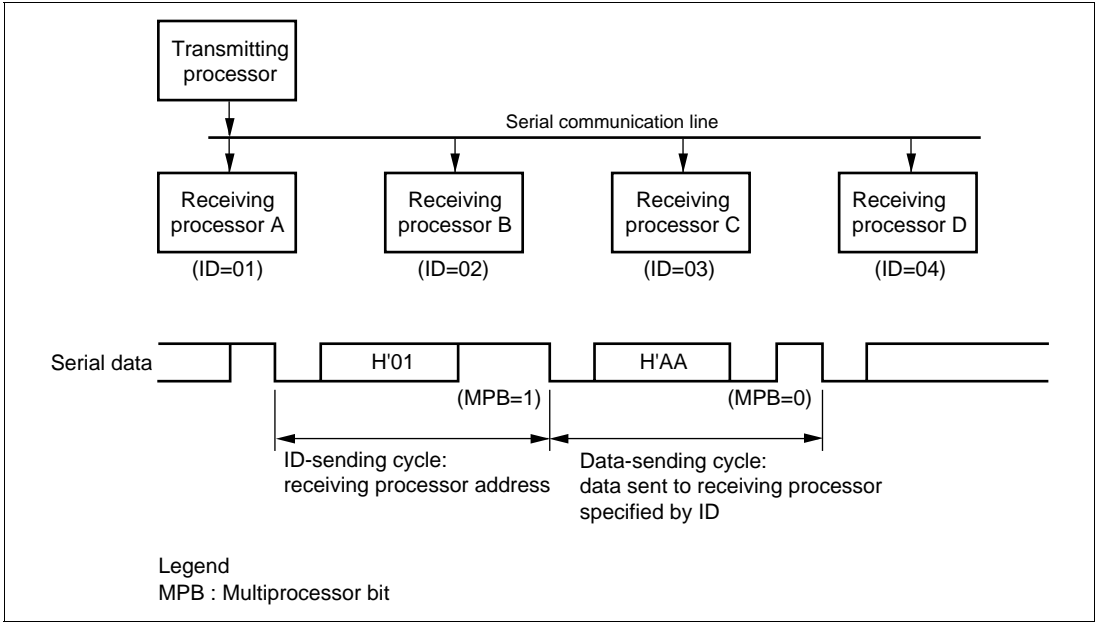

Figure 13.9 Example of Communication among Processors using Multiprocessor Format (Sending Data H'AA to Receiving Processor A)

Transmitting and Receiving Data:

- Transmitting Multiprocessor Serial Data: Figure 13.10 shows a sample flowchart for transmitting multiprocessor serial data and indicates the procedure to follow.

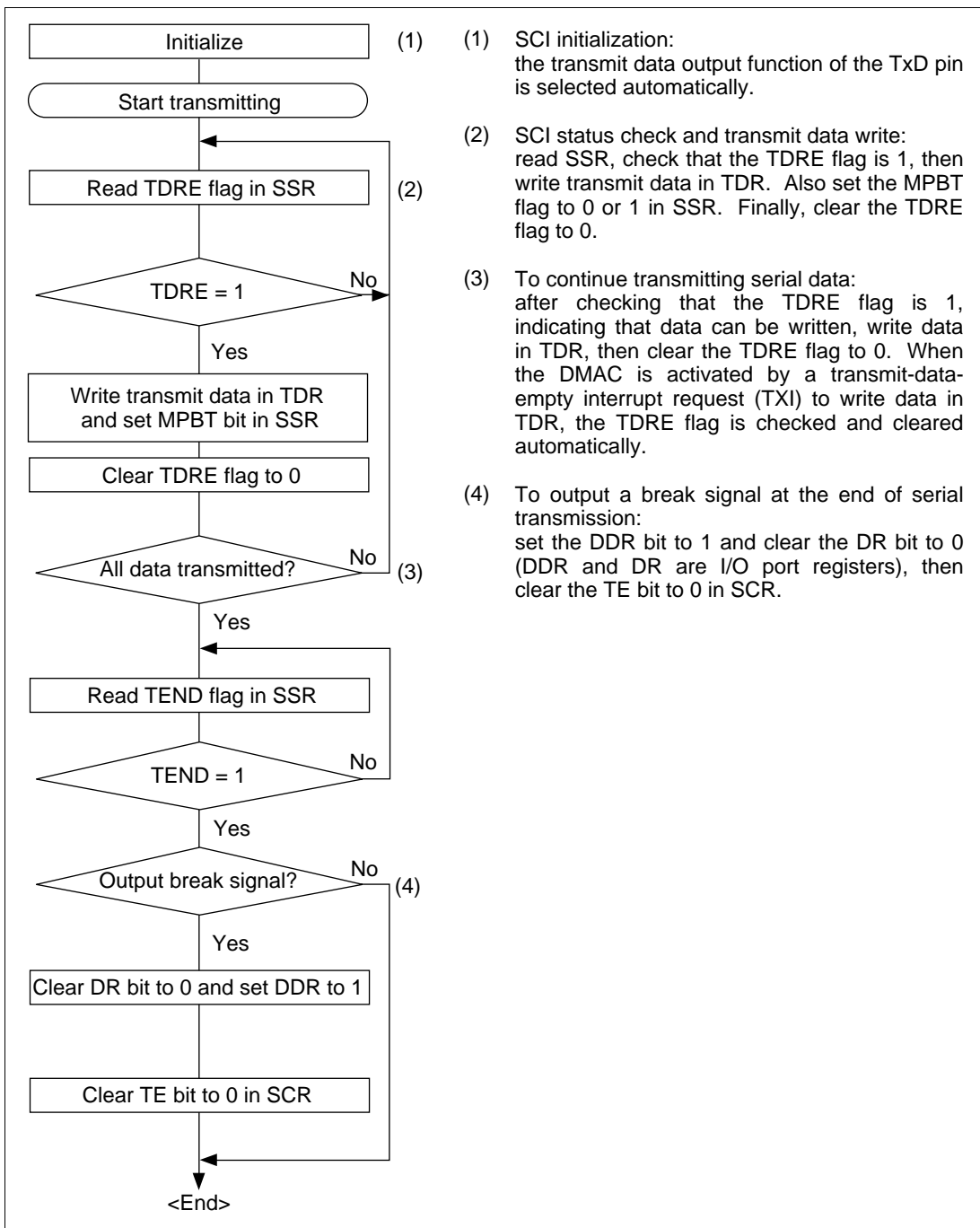
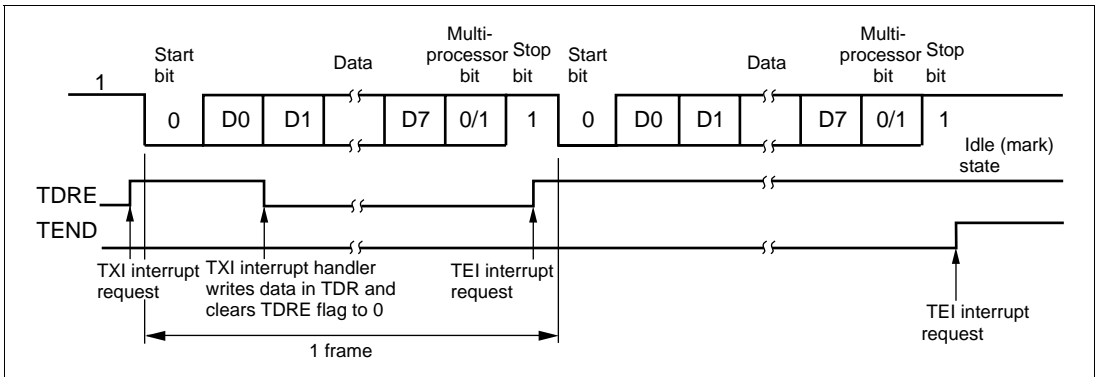

Figure 13.10 Sample Flowchart for Transmitting Multiprocessor Serial Data

In transmitting serial data, the SCI operates as follows:

- The SCI monitors the TDRE flag in SSR. When the TDRE flag is cleared to 0, the SCI recognizes that TDR contains new data, and loads this data from TDR into TSR.
- After loading the data from TDR to TSR, the SCI sets the TDRE flag to 1 and starts transmitting. If the TIE bit is set to 1 in SCR, the SCI requests a transmit-data-empty interrupt (TXI) at this time.
Serial transmit data is transmitted in the following order from the TxD pin:
 - Start bit: One 0 bit is output.
 - Transmit data: 7 or 8 bits are output, LSB first.
 - Multiprocessor bit: One multiprocessor bit (MPBT value) is output.
 - Stop bit(s): One or two 1 bits (stop bits) are output.
 - Mark state: Output of 1 bits continues until the start bit of the next transmit data.
- The SCI checks the TDRE flag when it outputs the stop bit. If the TDRE flag is 0, the SCI loads new data from TDR into TSR, outputs the stop bit, then begins serial transmission of the next frame. If the TDRE flag is 1, the SCI sets the TEND flag to 1 in SSR, outputs the stop bit, then continues output of 1 bits in the mark state. If the TEIE bit is set to 1 in SCR, a transmit-end interrupt (TEI) is requested at this time

Figure 13.11 shows an example of SCI transmit operation using a multiprocessor format.



**Figure 13.11 Example of SCI Transmit Operation
(8-Bit Data with Multiprocessor Bit and One Stop Bit)**

- Receiving Multiprocessor Serial Data: Figure 13.12 shows a sample flowchart for receiving multiprocessor serial data and indicates the procedure to follow.

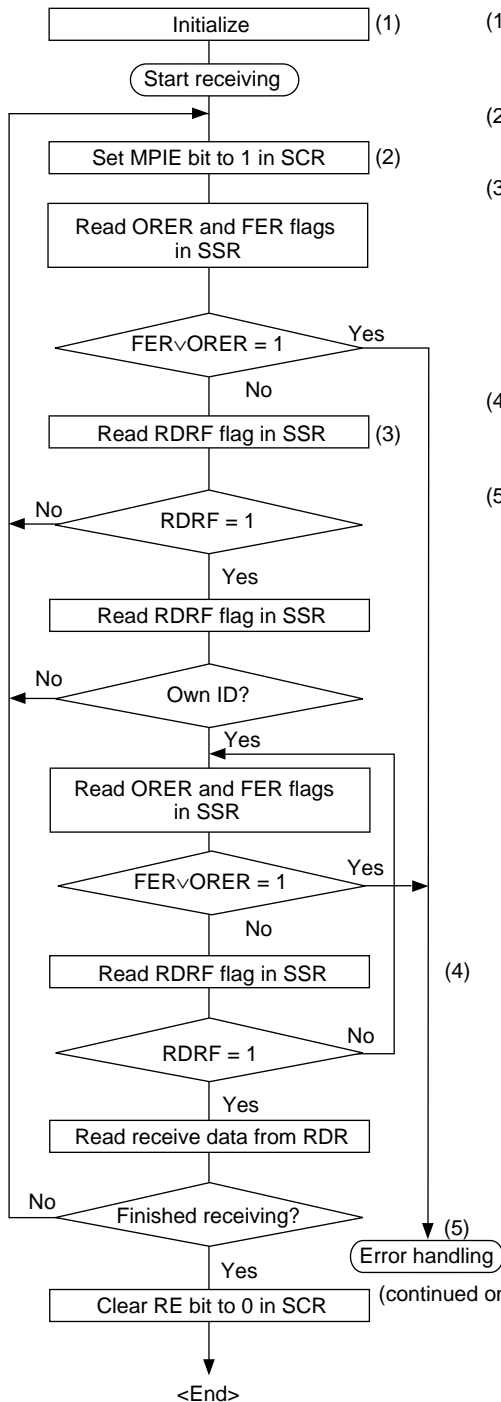

- (1) SCI initialization:
the receive data input function of the RxD pin is selected automatically.
- (2) ID receive cycle:
set the MPIE bit to 1 in SCR.
- (3) SCI status check and ID check:
read SSR, check that the RDRF flag is set to 1, then read data from RDR and compare it with the processor's own ID. If the ID does not match, set the MPIE bit to 1 again and clear the RDRF flag to 0. If the ID matches, clear the RDRF flag to 0.
- (4) SCI status check and data receiving:
read SSR, check that the RDRF flag is set to 1, then read data from RDR.
- (5) Receive error handling and break detection:
if a receive error occurs, read the ORER and FER flags in SSR to identify the error. After executing the necessary error handling, clear the ORER and FER flags both to 0. Receiving cannot resume while either the ORER or FER flag remains set to 1. When a framing error occurs, the RxD pin can be read to detect the break state.

(4)

(5)

(continued on next page)

Figure 13.12 Sample Flowchart for Receiving Multiprocessor Serial Data (1)

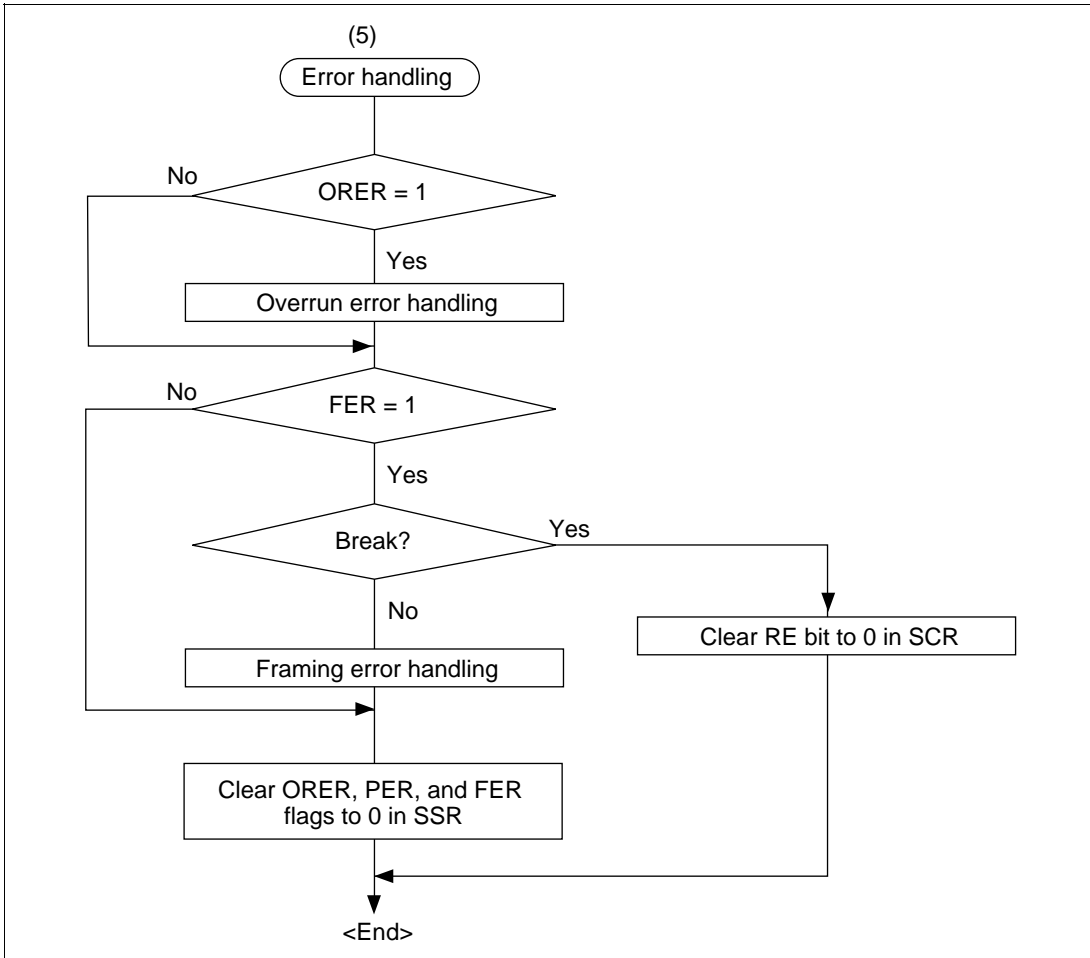

Figure 13.12 Sample Flowchart for Receiving Multiprocessor Serial Data (2)

Figure 13.13 shows an example of SCI receive operation using a multiprocessor format.

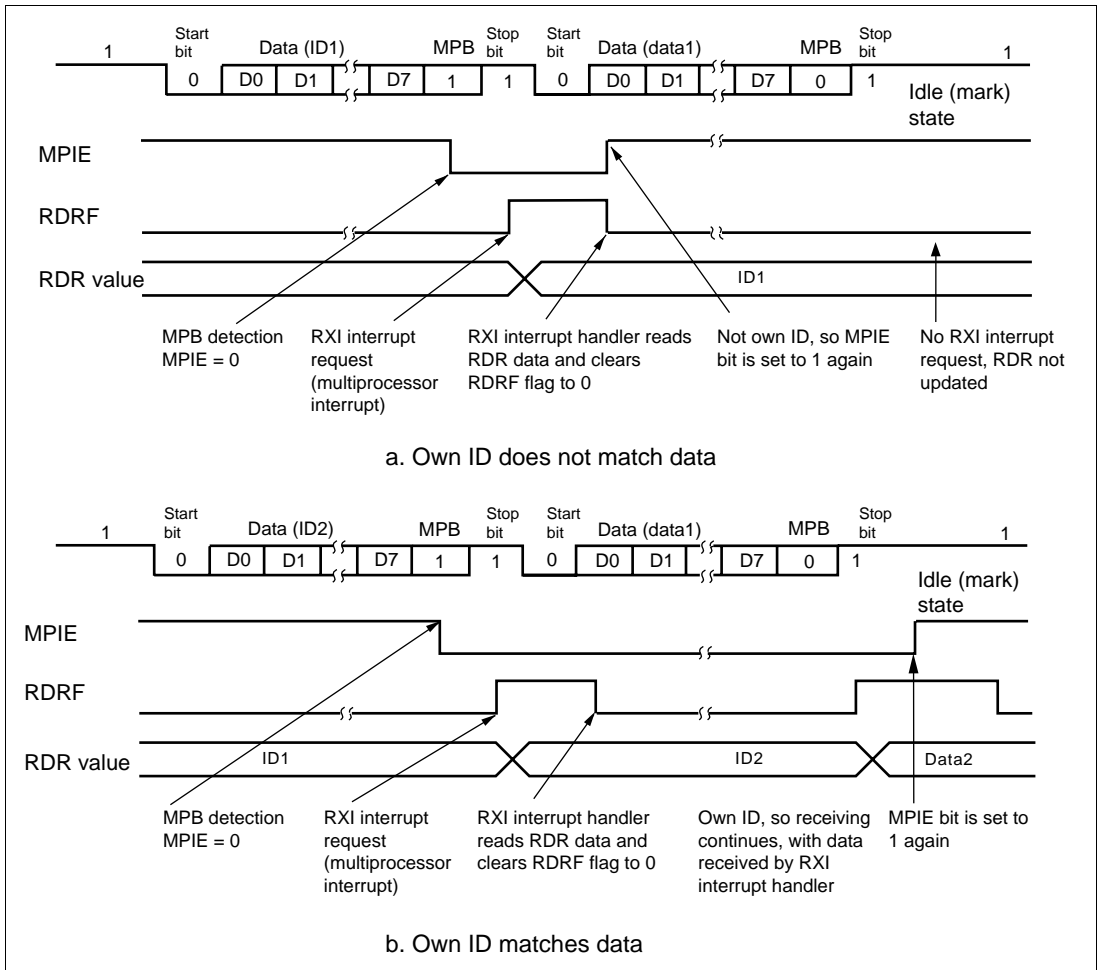

Figure 13.13 Example of SCI Receive Operation (8-Bit Data with Multiprocessor Bit and One Stop Bit)

13.3.4 Synchronous Operation

In synchronous mode, the SCI transmits and receives data in synchronization with clock pulses. This mode is suitable for high-speed serial communication.

The SCI transmitter and receiver share the same clock but are otherwise independent, so full-duplex communication is possible. The transmitter and the receiver are also double-buffered, so continuous transmitting or receiving is possible by reading or writing data while transmitting or receiving is in progress.

Figure 13.14 shows the general format in synchronous serial communication.

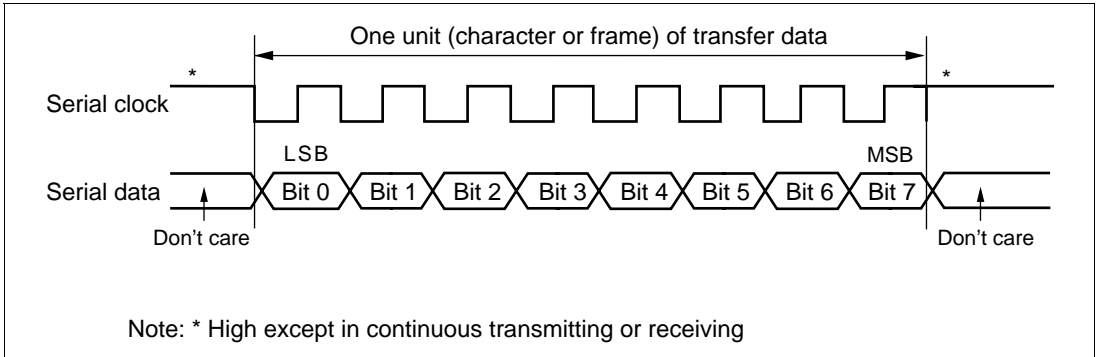

Figure 13.14 Data Format in Synchronous Communication

In synchronous serial communication, each data bit is placed on the communication line from one falling edge of the serial clock to the next. Data is guaranteed valid at the rise of the serial clock. In each character, the serial data bits are transferred in order from LSB (first) to MSB (last). After output of the MSB, the communication line remains in the state of the MSB. In synchronous mode the SCI receives data by synchronizing with the rise of the serial clock.

Communication Format: The data length is fixed at 8 bits. No parity bit or multiprocessor bit can be added.

Clock: An internal clock generated by the on-chip baud rate generator or an external clock input from the SCK pin can be selected by means of the $\overline{C/A}$ bit in SMR and the CKE1 and CKE0 bits in SCR. See table 13.9 for details of SCI clock source selection.

When the SCI operates on an internal clock, it outputs the clock source at the SCK pin. Eight clock pulses are output per transmitted or received character. When the SCI is not transmitting or receiving, the clock signal remains in the high state. If receiving in single-character units is required, an external clock should be selected.

Transmitting and Receiving Data:

- **SCI Initialization (Synchronous Mode):** Before transmitting or receiving data, clear the TE and RE bits to 0 in SCR, then initialize the SCI as follows.

When changing the communication mode or format, always clear the TE and RE bits to 0 before following the procedure given below. Clearing TE to 0 sets the TDRE flag to 1 and initializes TSR. Clearing RE to 0, however, does not initialize the RDRF, PER, FER, and ORER flags, or RDR, which retain their previous contents.

Figure 13.15 shows a sample flowchart for initializing the SCI.

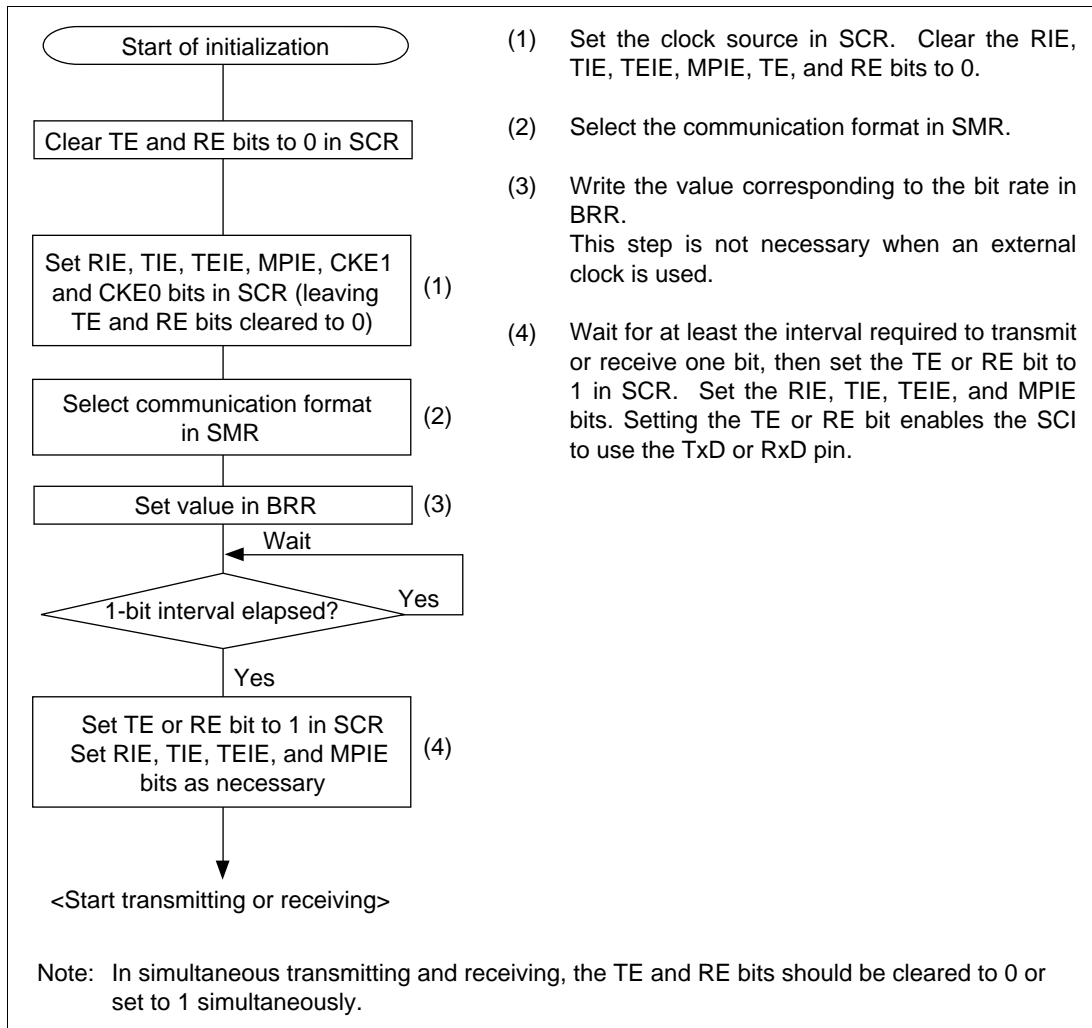

Figure 13.15 Sample Flowchart for SCI Initialization

- Transmitting Serial Data (Synchronous Mode): Figure 13.16 shows a sample flowchart for transmitting serial data and indicates the procedure to follow.

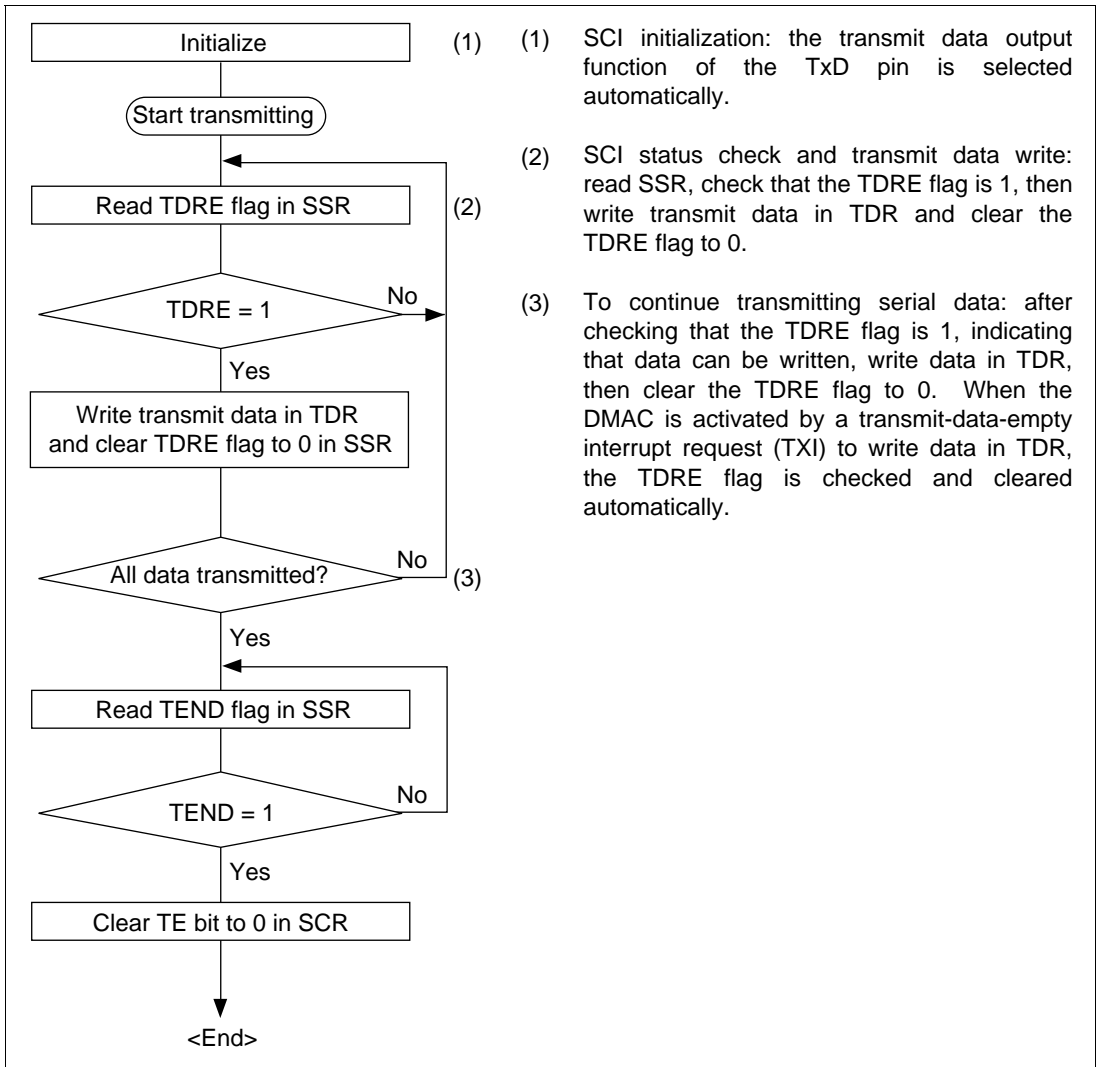

Figure 13.16 Sample Flowchart for Serial Transmitting

In transmitting serial data, the SCI operates as follows.

- The SCI monitors the TDRE flag in SSR. When the TDRE flag is cleared to 0, the SCI recognizes that TDR contains new data, and loads this data from TDR into TSR.
- After loading the data from TDR to TSR, the SCI sets the TDRE flag to 1 and starts transmitting. If the TIE bit is set to 1 in SCR, the SCI requests a transmit-data-empty interrupt (TXI) at this time.

If clock output is selected, the SCI outputs eight serial clock pulses. If an external clock source is selected, the SCI outputs data in synchronization with the input clock. Data is output from the TxD pin in order from LSB (bit 0) to MSB (bit 7).

- The SCI checks the TDRE flag when it outputs the MSB (bit 7). If the TDRE flag is 0, the SCI loads data from TDR into TSR and begins serial transmission of the next frame. If the TDRE flag is 1, the SCI sets the TEND flag to 1 in SSR, and after transmitting the MSB, holds the TxD pin in the MSB state. If the TEIE bit is set to 1 in SCR, a transmit-end interrupt (TEI) is requested at this time
- After the end of serial transmission, the SCK pin is held in a constant state.

Figure 13.17 shows an example of SCI transmit operation.

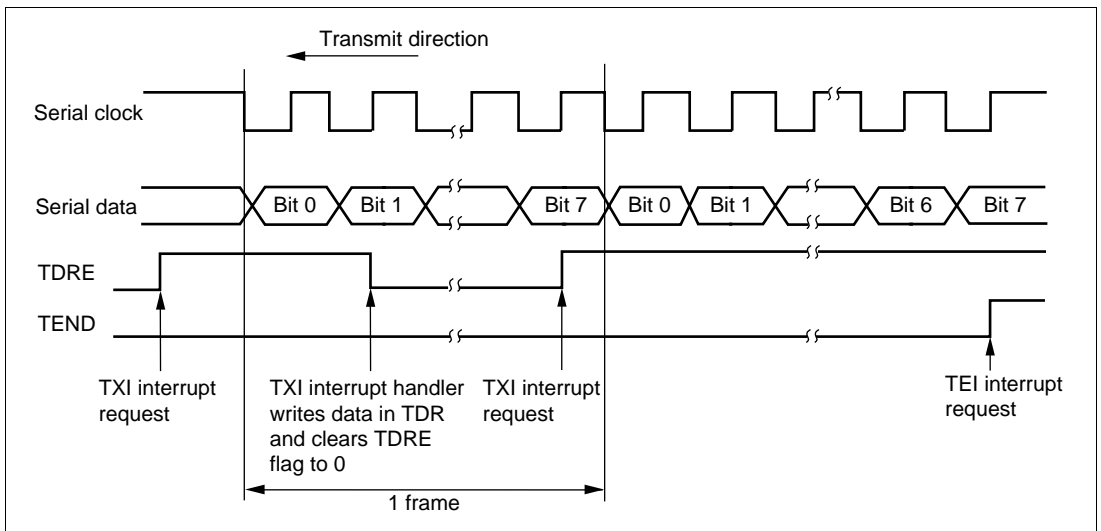

Figure 13.17 Example of SCI Transmit Operation

- Receiving Serial Data (Synchronous Mode): Figure 13.18 shows a sample flowchart for receiving serial data and indicates the procedure to follow. When switching from asynchronous to synchronous mode, make sure that the ORER, PER, and FER flags are cleared to 0. If the FER or PER flag is set to 1 the RDRF flag will not be set and both transmitting and receiving will be disabled.

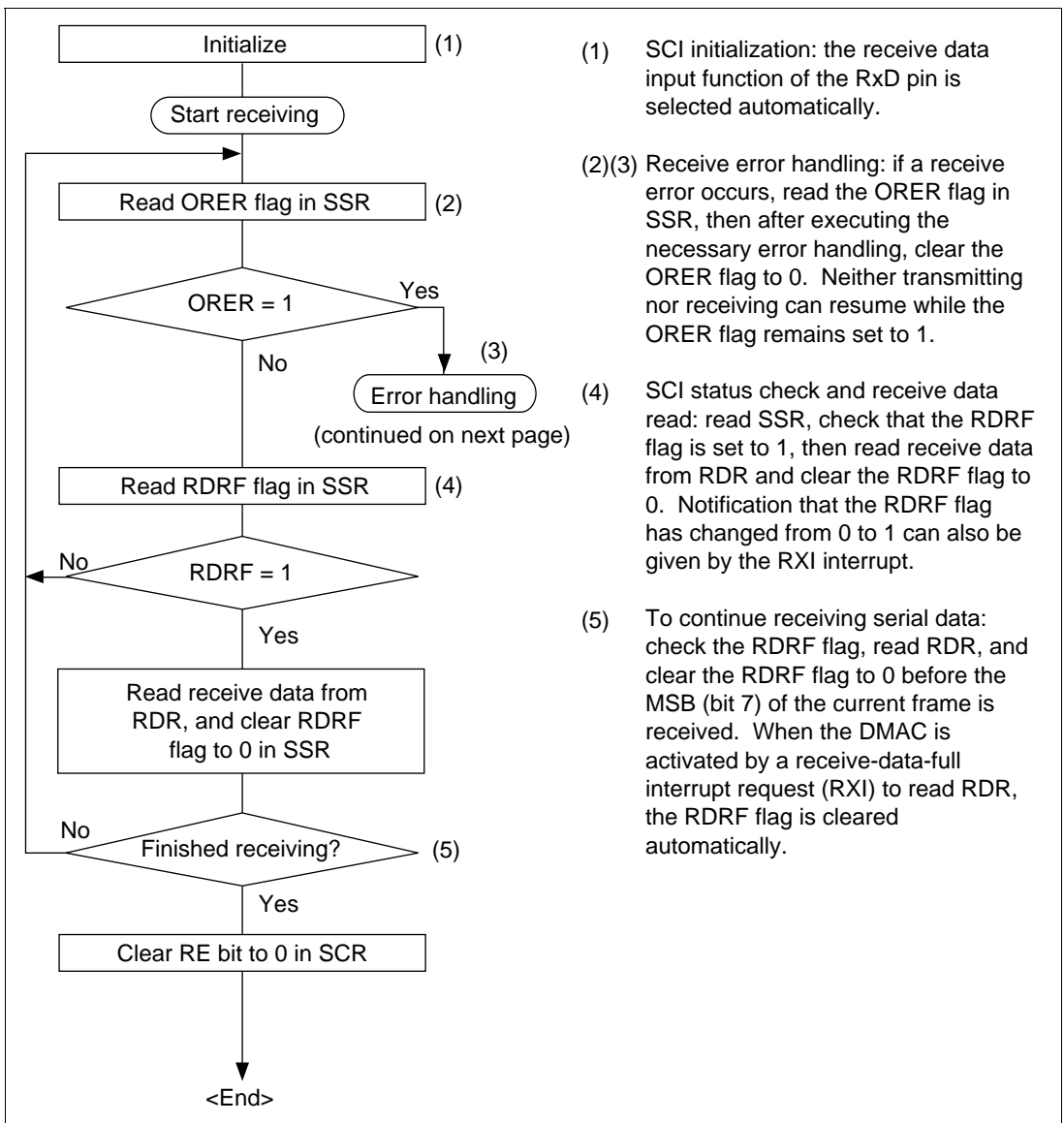

Figure 13.18 Sample Flowchart for Serial Receiving

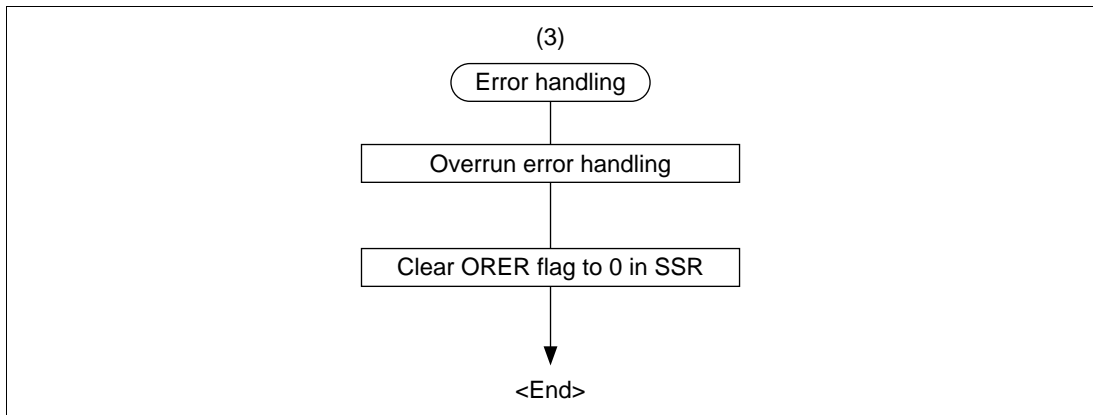

Figure 13.18 Sample Flowchart for Serial Receiving (cont)

In receiving, the SCI operates as follows:

- The SCI synchronizes with serial clock input or output and synchronizes internally.
- Receive data is stored in RSR in order from LSB to MSB.

After receiving the data, the SCI checks that the RDRF flag is 0, so that receive data can be transferred from RSR to RDR. If this check passes, the RDRF flag is set to 1 and the received data is stored in RDR. If the checks fails (receive error), the SCI operates as shown in table 13.11.

When a receive error has been identified in the error check, subsequent transmit and receive operations are disabled.

- When the RDRF flag is set to 1, if the RIE bit is set to 1 in SCR, a receive-data-full interrupt (RXI) is requested. If the ORER flag is set to 1 and the RIE bit in SCR is also set to 1, a receive-error interrupt (ERI) is requested.

Figure 13.19 shows an example of SCI receive operation.

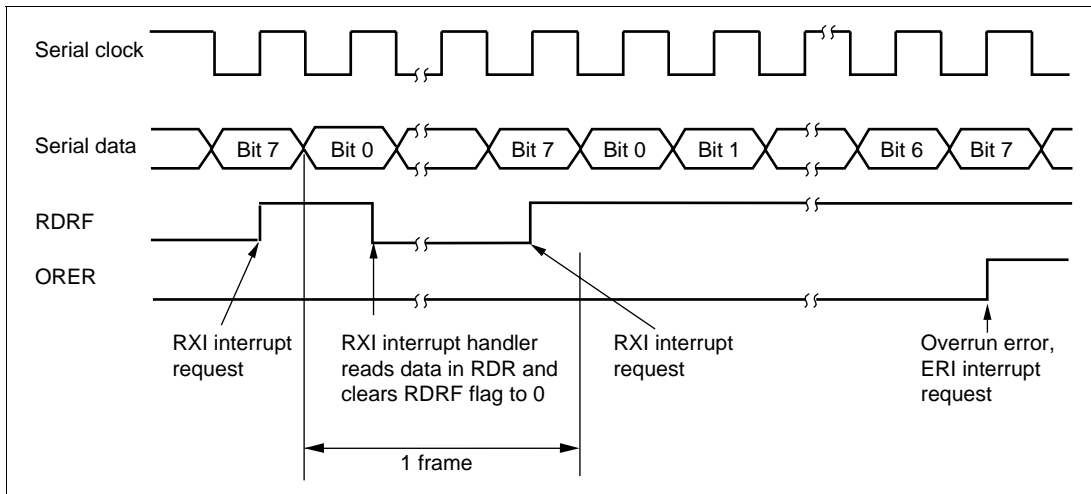

Figure 13.19 Example of SCI Receive Operation

- **Transmitting and Receiving Data Simultaneously (Synchronous Mode):** Figure 13.20 shows a sample flowchart for transmitting and receiving serial data simultaneously and indicates the procedure to follow.

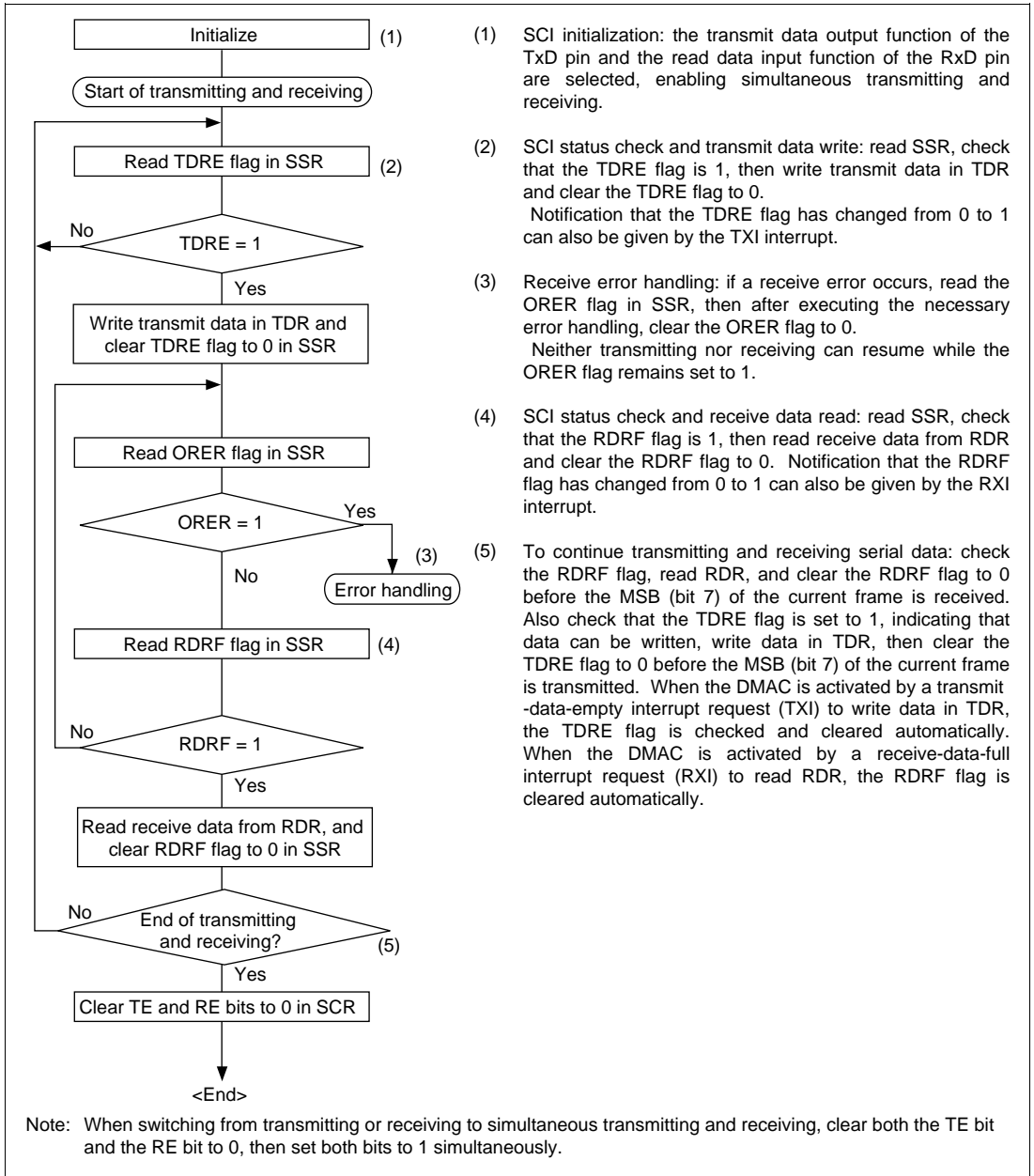

Figure 13.20 Sample Flowchart for Simultaneous Serial Transmitting and Receiving

13.4 SCI Interrupts

The SCI has four interrupt request sources: transmit-end interrupt (TEI), receive-error (ERI), receive-data-full (RXI), and transmit-data-empty interrupt (TXI). Table 13.12 lists the interrupt sources and indicates their priority. These interrupts can be enabled or disabled by the TIE, RIE, and TEIE bits in SCR. Each interrupt request is sent separately to the interrupt controller.

A TXI interrupt is requested when the TDRE flag is set to 1 in SSR. A TEI interrupt is requested when the TEND flag is set to 1 in SSR. A TXI interrupt request can activate the DMAC to transfer data. Data transfer by the DMAC automatically clears the TDRE flag to 0. A TEI interrupt request cannot activate the DMAC.

An RXI interrupt is requested when the RDRF flag is set to 1 in SSR. An ERI interrupt is requested when the ORER, PER, or FER flag is set to 1 in SSR. An RXI interrupt can activate the DMAC to transfer data. Data transfer by the DMAC automatically clears the RDRF flag to 0. An ERI interrupt request cannot activate the DMAC.

The DMAC can be activated by interrupts from SCI channel 0.

Table 13.12 SCI Interrupt Sources

Interrupt Source	Description	Priority
ERI	Receive error (ORER, FER, or PER)	High
RXI	Receive data register full (RDRF)	↑
TXI	Transmit data register empty (TDRE)	
TEI	Transmit end (TEND)	Low

13.5 Usage Notes

13.5.1 Notes on Use of SCI

Note the following points when using the SCI.

TDR Write and TDRE Flag: The TDRE flag in SSR is a status flag indicating the loading of transmit data from TDR to TSR. The SCI sets the TDRE flag to 1 when it transfers data from TDR to TSR.

Data can be written into TDR regardless of the state of the TDRE flag. If new data is written in TDR when the TDRE flag is 0, the old data stored in TDR will be lost because this data has not yet been transferred to TSR. Before writing transmit data in TDR, be sure to check that the TDRE flag is set to 1.

Simultaneous Multiple Receive Errors: Table 13.13 shows the state of the SSR status flags when multiple receive errors occur simultaneously. When an overrun error occurs the RSR contents are not transferred to RDR, so receive data is lost.

Table 13.13 SSR Status Flags and Transfer of Receive Data

SSR Status Flags				Receive Data Transfer	
RDRF	ORER	FER	PER	RSR → RDR	Receive Errors
1	1	0	0	Not transferred	Overrun error
0	0	1	0	Transferred	Framing error
0	0	0	1	Transferred	Parity error
1	1	1	0	Not transferred	Overrun error + framing error
1	1	0	1	Not transferred	Overrun error + parity error
0	0	1	1	Transferred	Framing error + parity error
1	1	1	1	Not transferred	Overrun error + framing error + parity error

Break Detection and Processing: Break signals can be detected by reading the RxD pin directly when a framing error (FER) is detected. In the break state the input from the RxD pin consists of all 0s, so the FER flag is set and the parity error flag (PER) may also be set. In the break state the SCI receiver continues to operate, so if the FER flag is cleared to 0 it will be set to 1 again.

Sending a Break Signal: The input/output condition and level of the TxD pin are determined by DR and DDR bits. This feature can be used to send a break signal.

After the serial transmitter is initialized, the DR value substitutes for the mark state until the TE bit is set to 1 (the TxD pin function is not selected until the TE bit is set to 1). The DDR and DR bits should therefore be set to 1 beforehand.

To send a break signal during serial transmission, clear the DR bit to 0, then clear the TE bit to 0. When the TE bit is cleared to 0 the transmitter is initialized, regardless of its current state, so the TxD pin becomes an input/output outputting the value 0.

Receive Error Flags and Transmitter Operation (Synchronous Mode Only): When a receive error flag (ORER, PER, or FER) is set to 1 the SCI will not start transmitting, even if the TDRE flag is cleared to 0. Be sure to clear the receive error flags to 0 when starting to transmit. Note that clearing the RE bit to 0 does not clear the receive error flags to 0.

Receive Data Sampling Timing in Asynchronous Mode and Receive Margin: In asynchronous mode the SCI operates on a base clock with 16 times the bit rate frequency. In receiving, the SCI synchronizes internally with the fall of the start bit, which it samples on the base clock. Receive data is latched at the rising edge of the eighth base clock pulse. See figure 13.21.

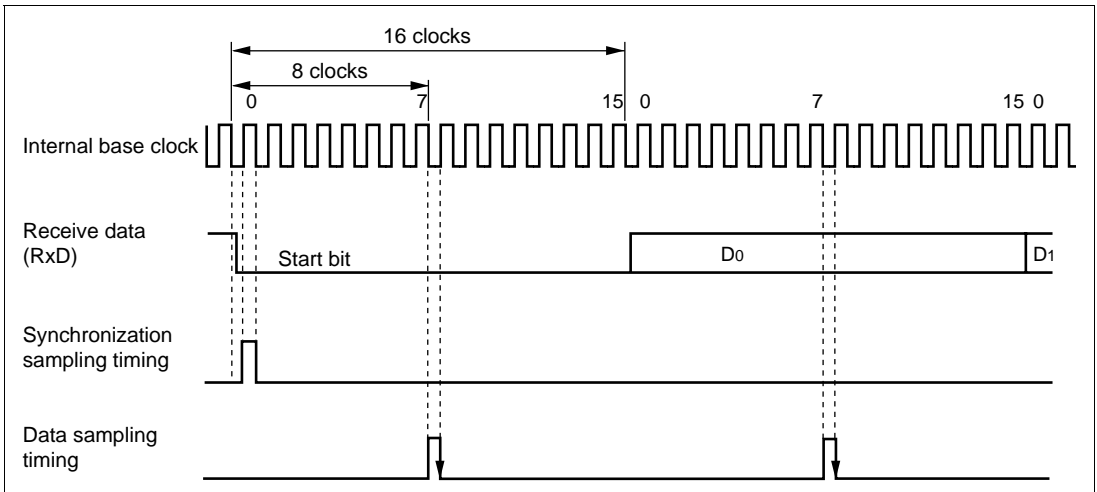

Figure 13.21 Receive Data Sampling Timing in Asynchronous Mode

The receive margin in asynchronous mode can therefore be expressed as shown in equation (1).

$$M = \left| \left(0.5 - \frac{1}{2N} \right) - (L - 0.5) F - \frac{|D - 0.5|}{N} (1 + F) \right| \times 100\% \dots\dots\dots (1)$$

- M: Receive margin (%)
- N: Ratio of clock frequency to bit rate (N = 16)
- D: Clock duty cycle (L = 0 to 1.0)
- L: Frame length (L = 9 to 12)
- F: Absolute deviation of clock frequency

From equation (1), if F = 0 and D = 0.5, the receive margin is 46.875%, as given by equation (2).

$$D = 0.5, F = 0$$

$$M = \left(0.5 - \frac{1}{2 \times 16} \right) \times 100\% = 46.875\% \dots\dots\dots (2)$$

This is a theoretical value. A reasonable margin to allow in system designs is 20% to 30%.

Restrictions on Use of DMAC:

- When an external clock source is used for the serial clock, after the DMAC updates TDR, allow an inversion of at least five system clock (ϕ) cycles before input of the serial clock to start transmitting. If the serial clock is input within four states of the TDR update, a malfunction may occur. (See figure 13.22)
- To have the DMAC read RDR, be sure to select the corresponding SCI receive-data-full interrupt (RXI) as the activation source with bits DTS2 to DTS0 in DTCR.

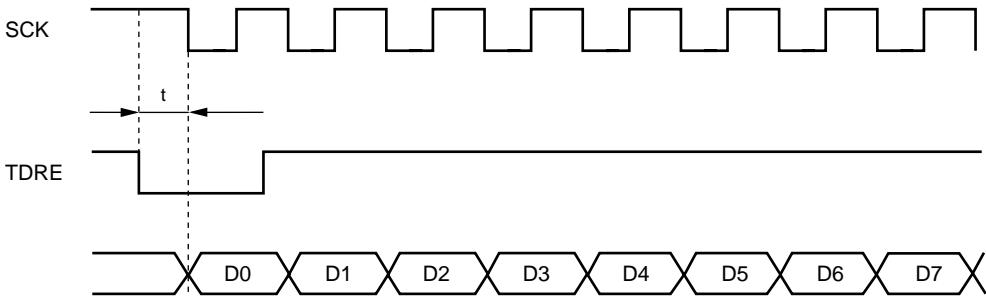

Note: In operation with an external clock source, be sure that $t > 4$ states.

Figure 13.22 Example of Synchronous Transmission Using DMAC

Switching from SCK Pin Function to Port Pin Function:

- Problem in Operation: When switching the SCK pin function to the output port function (high-level output) by making the following settings while $DDR = 1$, $DR = 1$, $C/\bar{A} = 1$, $CKE1 = 0$, $CKE0 = 0$, and $TE = 1$ (synchronous mode), low-level output occurs for one half-cycle.

1. End of serial data transmission
2. $TE = 0$
3. $C/\bar{A} = 0$... switchover to port output
4. Occurrence of low-level output (see figure 13.23)

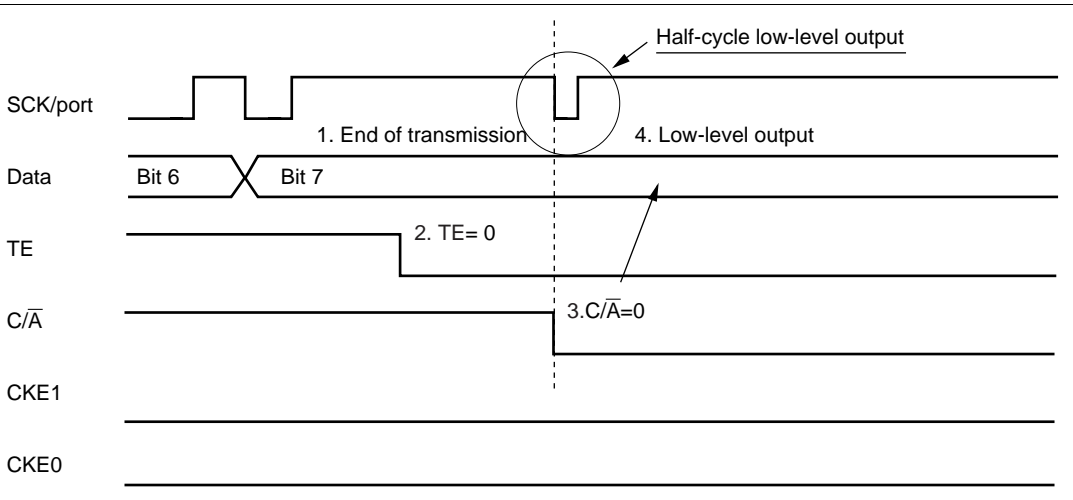

Figure 13.23 Operation when Switching from SCK Pin Function to Port Pin Function

- **Sample Procedure for Avoiding Low-Level Output:** As this sample procedure temporarily places the SCK pin in the input state, the SCK/port pin should be pulled up beforehand with an external circuit.

With $DDR = 1$, $DR = 1$, $C/\bar{A} = 1$, $CKE1 = 0$, $CKE0 = 0$, and $TE = 1$, make the following settings in the order shown.

1. End of serial data transmission
2. TE bit = 0
3. CKE1 bit = 1
4. C/\bar{A} bit = 0 ... switchover to port output
5. CKE1 bit = 0

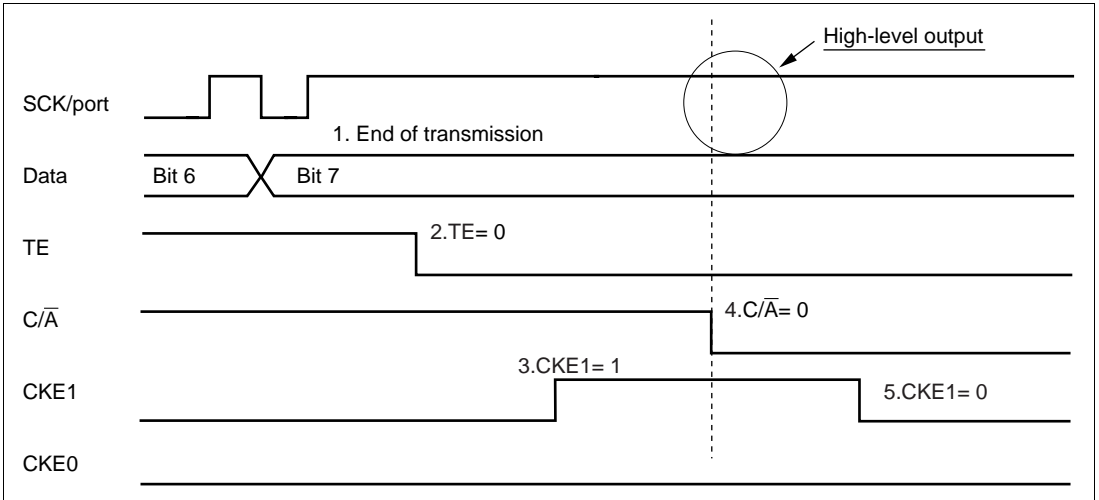

Figure 13.24 Operation when Switching from SCK Pin Function to Port Pin Function (Example of Preventing Low-Level Output)

Section 14 Smart Card Interface

14.1 Overview

An IC card (smart card) interface conforming to the ISO/IEC 7816-3 (Identification Card) standard is supported as an extension of the serial communication interface (SCI) functions.

Switchover between the normal serial communication interface and the smart card interface is controlled by a register setting.

14.1.1 Features

Features of the smart card interface supported by the H8/3067 Series are listed below.

- Asynchronous communication
 - Data length: 8 bits
 - Parity bit generation and checking
 - Transmission of error signal (parity error) in receive mode
 - Error signal detection and automatic data retransmission in transmit mode
 - Direct convention and inverse convention both supported
- Built-in baud rate generator allows any bit rate to be selected
- Three interrupt sources
 - There are three interrupt sources—transmit-data-empty, receive-data-full, and transmit/receive error—that can issue requests independently.
 - The transmit-data-empty interrupt and receive-data-full interrupt can activate the DMA controller (DMAC) to execute data transfer.

14.1.2 Block Diagram

Figure 14.1 shows a block diagram of the smart card interface.

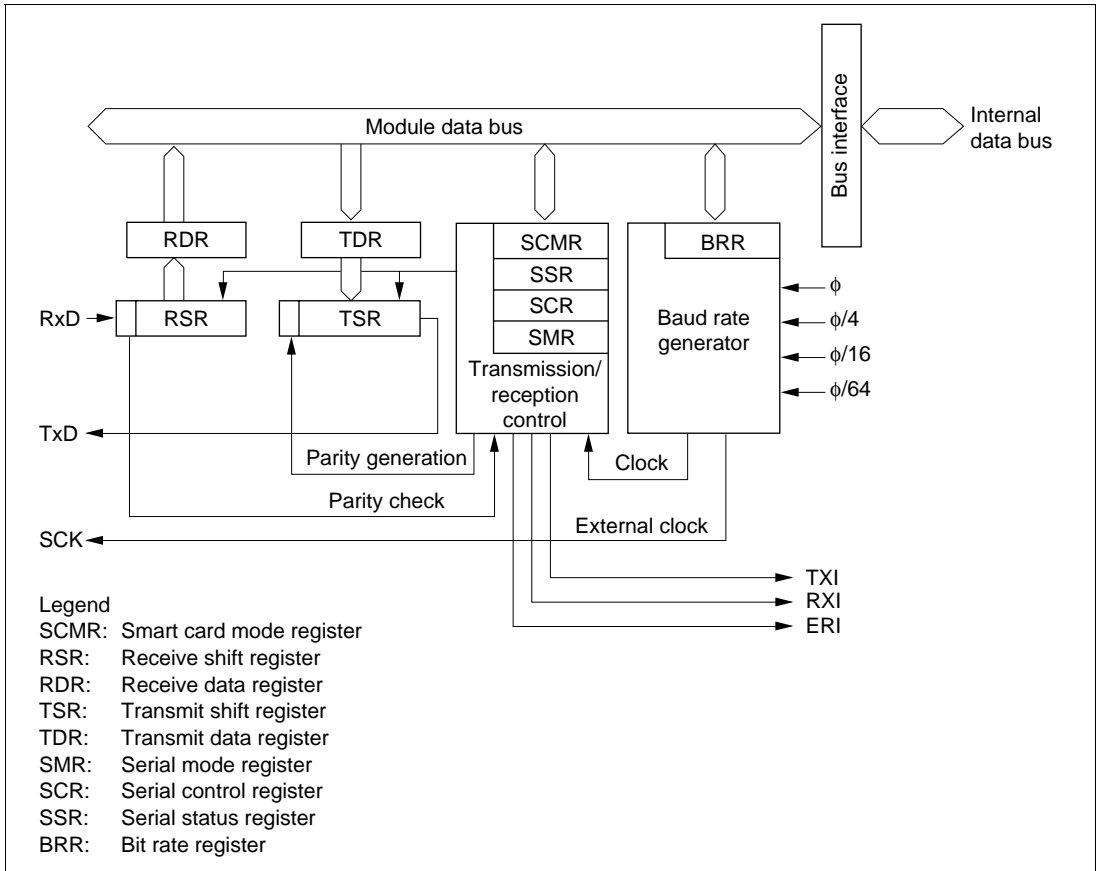

Figure 14.1 Block Diagram of Smart Card Interface

14.1.3 Pin Configuration

Table 14.1 shows the smart card interface pins.

Table 14.1 Smart Card Interface Pins

Pin Name	Abbreviation	I/O	Function
Serial clock pin	SCK	I/O	Clock input/output
Receive data pin	RxD	Input	Receive data input
Transmit data pin	TxD	Output	Transmit data output

14.1.4 Register Configuration

The smart card interface has the internal registers listed in table 14.2. The BRR, TDR, and RDR registers have their normal serial communication interface functions, as described in section 13, Serial Communication Interface.

Table 14.2 Smart Card Interface Registers

Channel	Address* ¹	Name	Abbreviation	R/W	Initial Value
0	H'FFFB0	Serial mode register	SMR	R/W	H'00
	H'FFFB1	Bit rate register	BRR	R/W	H'FF
	H'FFFB2	Serial control register	SCR	R/W	H'00
	H'FFFB3	Transmit data register	TDR	R/W	H'FF
	H'FFFB4	Serial status register	SSR	R/(W)* ²	H'84
	H'FFFB5	Receive data register	RDR	R	H'00
	H'FFFB6	Smart card mode register	SCMR	R/W	H'F2
1	H'FFFB8	Serial mode register	SMR	R/W	H'00
	H'FFFB9	Bit rate register	BRR	R/W	H'FF
	H'FFBBA	Serial control register	SCR	R/W	H'00
	H'FFFB B	Transmit data register	TDR	R/W	H'FF
	H'FFFB C	Serial status register	SSR	R/(W)* ²	H'84
	H'FFFB D	Receive data register	RDR	R	H'00
	H'FFFB E	Smart card mode register	SCMR	R/W	H'F2
2	H'FFFC0	Serial mode register	SMR	R/W	H'00
	H'FFFC1	Bit rate register	BRR	R/W	H'FF
	H'FFFC2	Serial control register	SCR	R/W	H'00
	H'FFFC3	Transmit data register	TDR	R/W	H'FF
	H'FFFC4	Serial status register	SSR	R/(W)* ²	H'84
	H'FFFC5	Receive data register	RDR	R	H'00
	H'FFFC6	Smart card mode register	SCMR	R/W	H'F2

- Notes: 1. Lower 20 bits of the address in advanced mode.
 2. Only 0 can be written in bits 7 to 3, to clear the flags.

14.2 Register Descriptions

This section describes the new or modified registers and bit functions in the smart card interface.

14.2.1 Smart Card Mode Register (SCMR)

SCMR is an 8-bit readable/writable register that selects smart card interface functions.

Bit	7	6	5	4	3	2	1	0
	—	—	—	—	SDIR	SINV	—	SMIF
Initial value	1	1	1	1	0	0	1	0
Read/Write	—	—	—	—	R/W	R/W	—	R/W

Reserved bits
Reserved bit

Smart card data invert
Inverts data logic levels
Smart card data transfer direction
Selects the serial/parallel conversion format

Smart card interface mode select
Enables or disables the smart card interface function

SCMR is initialized to H'F2 by a reset and in standby mode.

Bits 7 to 4—Reserved: Read-only bits, always read as 1.

Bit 3—Smart Card Data Transfer Direction (SDIR): Selects the serial/parallel conversion format.*¹

Bit 3 SDIR	Description
0	TDR contents are transmitted LSB-first Receive data is stored LSB-first in RDR (Initial value)
1	TDR contents are transmitted MSB-first Receive data is stored MSB-first in RDR

Bit 2—Smart Card Data Invert (SINV): Specifies inversion of the data logic level. This function is used in combination with the SDIR bit to communicate with inverse-convention cards.*² The SINV bit does not affect the logic level of the parity bit. For parity settings, see section 14.3.4, Register Settings.

Bit 2 SINV	Description	
0	Unmodified TDR contents are transmitted Receive data is stored unmodified in RDR	(Initial value)
1	Inverted TDR contents are transmitted Receive data is inverted before storage in RDR	

Bit 1—Reserved: Read-only bit, always read as 1.

Bit 0—Smart Card Interface Mode Select (SMIF): Enables the smart card interface function.

Bit 0 SMIF	Description	
0	Smart card interface function is disabled	(Initial value)
1	Smart card interface function is enabled	

- Notes:
1. The function for switching between LSB-first and MSB-first mode can also be used with the normal serial communication interface. Note that when the communication format data length is set to 7 bits and MSB-first mode is selected for the serial data to be transferred, bit 0 of TDR is not transmitted, and only bits 7 to 1 of the received data are valid.
 2. The data logic level inversion function can also be used with the normal serial communication interface. Note that, when inverting the serial data to be transferred, parity transmission and parity checking is based on the number of high-level periods at the serial data I/O pin, and not on the register value.

14.2.2 Serial Status Register (SSR)

The function of SSR bit 4 is modified in smart card interface mode. This change also causes a modification to the setting conditions for bit 2 (TEND).

Bit	7	6	5	4	3	2	1	0
	TDRE	RDRF	ORER	ERS	PER	TEND	MPB	MPBT
Initial value	1	0	0	0	0	1	0	0
Read/Write	R/(W)*	R/(W)*	R/(W)*	R/(W)*	R/(W)*	R	R	R/W

Transmit end
Status flag indicating end of transmission
Error signal status (ERS)
Status flag indicating that an error signal has been received

Note: * Only 0 can be written, to clear the flag.

Bits 7 to 5: These bits operate as in normal serial communication. For details see section 13.2.7, Serial Status Register (SSR).

Bit 4—Error Signal Status (ERS): In smart card interface mode, this flag indicates the status of the error signal sent from the receiving device to the transmitting device. The smart card interface does not detection framing errors.

Bit 4

ERS	Description
0	Indicates normal transmission, with no error signal returned (Initial value) [Clearing conditions] <ul style="list-style-type: none"> The chip is reset, or enters standby mode or module stop mode Software reads ERS while it is set to 1, then writes 0.
1	Indicates that the receiving device sent an error signal reporting a parity error [Setting condition] A low error signal was sampled.

Note: Clearing the TE bit to 0 in SCR does not affect the ERS flag, which retains its previous value.

Bits 3 to 0: These bits operate as in normal serial communication. For details see section 13.2.7, Serial Status Register (SSR). The setting conditions for transmit end (TEND, bit 2), however, are modified as follows.

Bit 2

TEND	Description
0	Transmission is in progress [Clearing conditions] <ul style="list-style-type: none">• Software reads TDRE while it is set to 1, then writes 0 in the TDRE flag.• The DMAC writes data in TDR.
1	End of transmission [Setting conditions] (Initial value) <ul style="list-style-type: none">• The chip is reset or enters standby mode.• The TE bit and FER/ERS bit are both cleared to 0 in SCR.• TDRE is 1 and ERS is 0 at a time 2.5 etu after the last bit of a 1-byte serial character is transmitted (normal transmission).

Note: An etu (elementary time unit) is the time needed to transmit one bit.

14.2.3 Serial Mode Register (SMR)

The function of SMR bit 7 is modified in smart card interface mode. This change also causes a modification to the function of bits 1 and 0 in the serial control register (SCR).

Bit	7	6	5	4	3	2	1	0
	GM	CHR	PE	O/ \bar{E}	STOP	MP	CKS1	CKS0
Initial value	0	0	0	0	0	0	0	0
Read/Write	R/W	R/W	R/W	R/W	R/W	R/W	R/W	R/W

Bit 7—GSM Mode (GM): With the normal smart card interface, this bit is cleared to 0. Setting this bit to 1 selects GSM mode, an additional mode for controlling the timing for setting the TEND flag that indicates completion of transmission, and the type of clock output used. The details of the additional clock output control mode are specified by the CKE1 and CKE0 bits in the serial control register (SCR).

Bit 7

GM	Description
0	Normal smart card interface mode operation <ul style="list-style-type: none"> The TEND flag is set 12.5 etu after the beginning of the start bit. Clock output on/off control only. (Initial value)
1	GSM mode smart card interface mode operation <ul style="list-style-type: none"> The TEND flag is set 11.0 etu after the beginning of the start bit. Clock output on/off and fixed-high/fixed-low control.

Bits 6 to 0: These bits operate as in normal serial communication. For details see section 13.2.5, Serial Mode Register (SMR).

14.2.4 Serial Control Register (SCR)

The function of SCR bits 1 and 0 is modified in smart card interface mode.

Bit	7	6	5	4	3	2	1	0
	TIE	RIE	TE	RE	MPIE	TEIE	CKE1	CKE0
Initial value	0	0	0	0	0	0	0	0
Read/Write	R/W	R/W	R/W	R/W	R/W	R/W	R/W	R/W

Bits 7 to 2: These bits operate as in normal serial communication. For details see section 13.2.6, Serial Control Register (SCR).

Bits 1 and 0—Clock Enable 1 and 0 (CKE1, CKE0): These bits select the SCI clock source and enable or disable clock output from the SCK pin. In smart card interface mode, it is possible to specify a fixed high level or fixed low level for the clock output, in addition to the usual switching between enabling and disabling of the clock output.

Bit 7 GM	Bit 1 CKE1	Bit 0 CKE0	Description
0	0	0	Internal clock/SCK pin is I/O port (Initial value)
		1	Internal clock/SCK pin is clock output
1	0	0	Internal clock/SCK pin is fixed at low output
		1	Internal clock/SCK pin is clock output
	1	0	Internal clock/SCK pin is fixed at high output
		1	Internal clock/SCK pin is clock output

14.3 Operation

14.3.1 Overview

The main features of the smart card interface are as follows.

- One frame consists of 8-bit data plus a parity bit.
- In transmission, a guard time of at least 2 etu (elementary time units: the time for transfer of one bit) is provided between the end of the parity bit and the start of the next frame.
- If a parity error is detected during reception, a low error signal level is output for a 1 etu period 10.5 etu after the start bit.
- If an error signal is detected during transmission, the same data is transmitted automatically after the elapse of 2 etu or longer.
- Only asynchronous communication is supported; there is no synchronous communication function.

14.3.2 Pin Connections

Figure 14.2 shows a pin connection diagram for the smart card interface.

In communication with a smart card, since both transmission and reception are carried out on a single data transmission line, the TxD pin and RxD pin should both be connected to this line. The data transmission line should be pulled up to V_{CC} with a resistor.

When the smart card uses the clock generated on the smart card interface, the SCK pin output is input to the CLK pin of the smart card. If the smart card uses an internal clock, this connection is unnecessary.

The reset signal should be output from one of this LSI's generic ports.

In addition to these pin connections, power and ground connections will normally also be necessary.

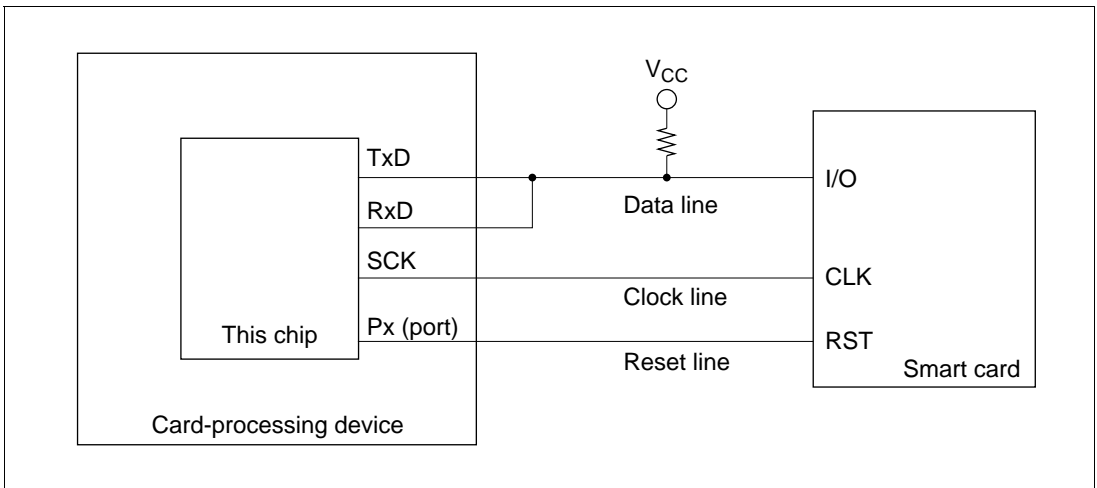

Figure 14.2 Smart Card Interface Connection Diagram

Note: If an IC card is not connected, and both TE and RE are set to 1, closed transmission/reception is possible, enabling self-diagnosis to be carried out.

14.3.3 Data Format

Figure 14.3 shows the smart card interface data format. In reception in this mode, a parity check is carried out on each frame, and if an error is detected an error signal is sent back to the transmitting device to request retransmission of the data. In transmission, the error signal is sampled and the same data is retransmitted if the error signal is low.

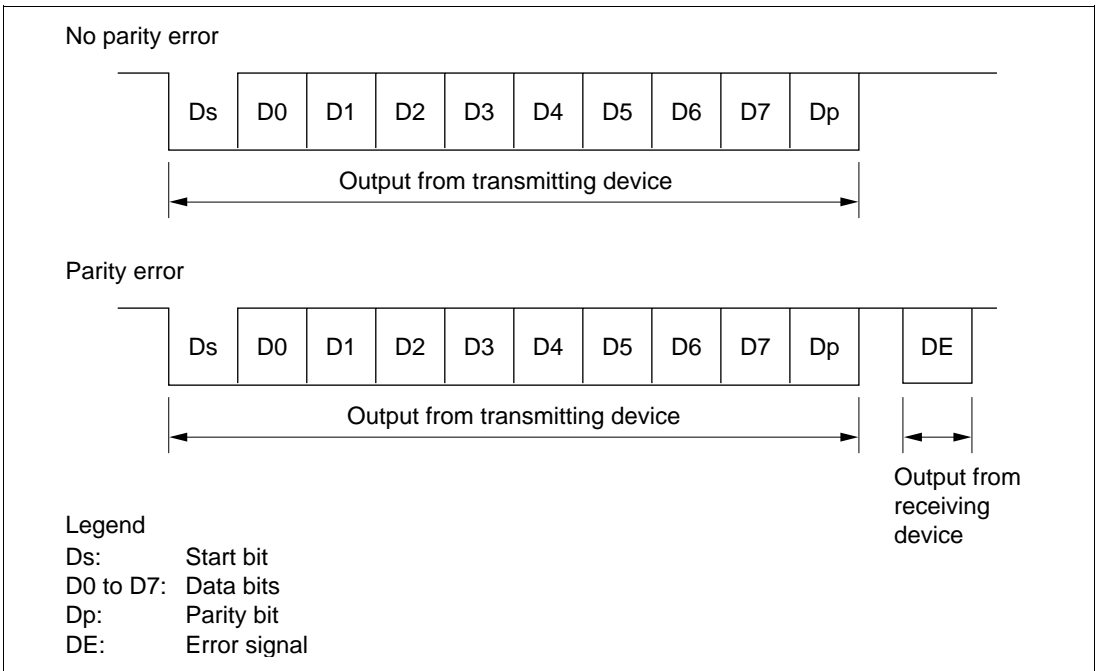

Figure 14.3 Smart Card Interface Data Format

The operating sequence is as follows.

1. When the data line is not in use it is in the high-impedance state, and is fixed high with a pull-up resistor.
2. The transmitting device starts transfer of one frame of data. The data frame starts with a start bit (Ds, low-level), followed by 8 data bits (D0 to D7) and a parity bit (Dp).
3. With the smart card interface, the data line then returns to the high-impedance state. The data line is pulled high with a pull-up resistor.
4. The receiving device carries out a parity check. If there is no parity error and the data is received normally, the receiving device waits for reception of the next data. If a parity error occurs, however, the receiving device outputs an error signal (DE, low-level) to request retransmission of the data. After outputting the error signal for the prescribed length of time, the receiving device places the signal line in the high-impedance state again. The signal line is pulled high again by a pull-up resistor.
5. If the transmitting device does not receive an error signal, it proceeds to transmit the next data frame. If it receives an error signal, however, it returns to step 2 and transmits the same data again.

14.3.4 Register Settings

Table 14.3 shows a bit map of the registers used in the smart card interface. Bits indicated as 0 or 1 must be set to the value shown. The setting of other bits is described in this section.

Table 14.3 Smart Card Interface Register Settings

Register	Address ¹	Bit							
		Bit 7	Bit 6	Bit 5	Bit 4	Bit 3	Bit 2	Bit 1	Bit 0
SMR	H'FFFB0	GM	0	1	O/ \bar{E}	1	0	CKS1	CKS0
BRR	H'FFFB1	BRR7	BRR6	BRR5	BRR4	BRR3	BRR2	BRR1	BRR0
SCR	H'FFFB2	TIE	RIE	TE	RE	0	0	CKE1 ^{*2}	CKE0
TDR	H'FFFB3	TDR7	TDR6	TDR5	TDR4	TDR3	TDR2	TDR1	TDR0
SSR	H'FFFB4	TDRE	RDRF	ORER	ERS	PER	TEND	0	0
RDR	H'FFFB5	RDR7	RDR6	RDR5	RDR4	RDR3	RDR2	RDR1	RDR0
SCMR	H'FFFB6	—	—	—	—	SDIR	SINV	—	SMIF

Notes: — Unused bit.

1. Lower 20 bits of the address in advanced mode.
2. When GM is cleared to 0 in SMR, the CKE1 bit must also be cleared to 0.

Serial Mode Register (SMR) Settings: Clear the GM bit to 0 when using the normal smart card interface mode, or set to 1 when using GSM mode. Clear the O/ \bar{E} bit to 0 if the smart card is of the direct convention type, or set to 1 if of the inverse convention type.

Bits CKS1 and CKS0 select the clock source of the built-in baud rate generator. See section 14.3.5, Clock.

Bit Rate Register (BRR) Settings: BRR is used to set the bit rate. See section 14.3.5, Clock, for the method of calculating the value to be set.

Serial Control Register (SCR) Settings: The TIE, RIE, TE, and RE bits have their normal serial communication functions. See section 13, Serial Communication Interface, for details. The CKE1 and CKE0 bits specify clock output. To disable clock output, clear these bits to 00; to enable clock output, set these bits to 01. Clock output is not performed when the GM bit is set to 1 in SMR. Clock output can also be fixed low or high.

Smart Card Mode Register (SCMR) Settings: Clear both the SDIR bit and SINV bit cleared to 0 if the smart card is of the direct convention type, and set both to 1 if of the inverse convention type. To use the smart card interface, set the SMIF bit to 1.

The register settings and examples of starting character waveforms are shown below for two smart cards, one following the direct convention and one the inverse convention.

1. Direct Convention ($SDIR = SINV = O\bar{E} = 0$)

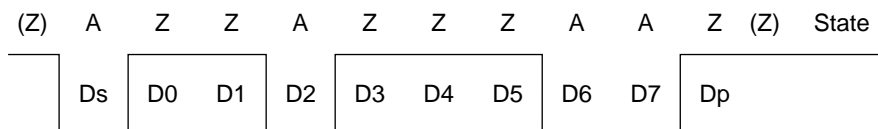

With the direct convention type, the logic 0 level corresponds to state Z and the logic 1 level to state A, and transfer is performed in LSB-first order. In the example above, the first character data is H'3B. The parity bit is 1, following the even parity rule designated for smart cards.

2. Indirect Convention ($SDIR = SINV = O\bar{E} = 1$)

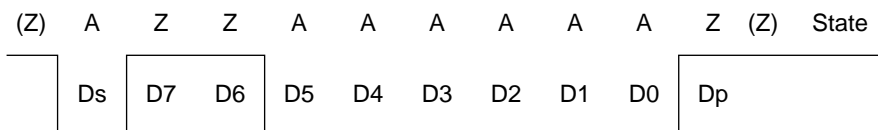

With the indirect convention type, the logic 1 level corresponds to state A and the logic 0 level to state Z, and transfer is performed in MSB-first order. In the example above, the first character data is H'3F. The parity bit is 0, corresponding to state Z, following the even parity rule designated for smart cards.

In the H8/3067 Series, inversion specified by the SINV bit applies only to the data bits, D7 to D0. For parity bit inversion, the $O\bar{E}$ bit in SMR must be set to odd parity mode. This applies to both transmission and reception.

14.3.5 Clock

Only an internal clock generated by the on-chip baud rate generator can be used as the transmit/receive clock for the smart card interface. The bit rate is set with the bit rate register (BRR) and the CKS1 and CKS0 bits in the serial mode register (SMR). The equation for calculating the bit rate is shown below. Table 14.5 shows some sample bit rates.

If clock output is selected with CKE0 set to 1, a clock with a frequency of 372 times the bit rate is output from the SCK pin.

$$B = \frac{\phi}{1488 \times 2^{2n-1} \times (N + 1)} \times 10^6$$

where, N: BRR setting ($0 \leq N \leq 255$)

B: Bit rate (bit/s)

ϕ : Operating frequency (MHz)

n: See table 14.4

Table 14.4 n-Values of CKS1 and CKS0 Settings

n	CKS1	CKS0
0	0	0
1		1
2	1	0
3		1

Note: If the gear function is used to divide the clock frequency, use the divided frequency to calculate the bit rate. The equation above applies directly to 1/1 frequency division.

Table 14.5 Bit Rates (bits/s) for Various BRR Settings (When n = 0)

N	ϕ (MHz)							
	7.1424	10.00	10.7136	13.00	14.2848	16.00	18.00	20.00
0	9600.0	13440.9	14400.0	17473.1	19200.0	21505.4	24193.5	26881.7
1	4800.0	6720.4	7200.0	8736.6	9600.0	10752.7	12096.8	13440.9
2	3200.0	4480.3	4800.0	5824.4	6400.0	7168.5	8064.5	8960.6

Note: Bit rates are rounded off to one decimal place.

The following equation calculates the bit rate register (BRR) setting from the operating frequency and bit rate. N is an integer from 0 to 255, specifying the value with the smaller error.

$$N = \frac{\phi}{1488 \times 2^{2n-1} \times B} \times 10^6 - 1$$

Table 14.6 BRR Settings for Typical Bit Rates (bits/s) (When n = 0)

bit/s	ϕ (MHz)							
	<u>7.1424</u>	<u>10.00</u>	<u>10.7136</u>	<u>13.00</u>	<u>14.2848</u>	<u>16.00</u>	<u>18.00</u>	<u>20.00</u>
	N Error	N Error	N Error	N Error	N Error	N Error	N Error	N Error
9600	0 0.00	1 30	1 25	1 8.99	1 0.00	1 12.01	2 15.99	2 6.66

Table 14.7 Maximum Bit Rates for Various Frequencies (Smart Card Interface Mode)

ϕ (MHz)	Maximum Bit Rate (bits/s)	N	n
7.1424	9600	0	0
10.00	13441	0	0
10.7136	14400	0	0
13.00	17473	0	0
14.2848	19200	0	0
16.00	21505	0	0
18.00	24194	0	0
20.00	26882	0	0

The bit rate error is given by the following equation:

$$\text{Error (\%)} = \left(\frac{\phi}{1488 \times 2^{2n-1} \times B \times (N + 1)} \times 10^6 - 1 \right) \times 100$$

14.3.6 Transmitting and Receiving Data

Initialization: Before transmitting or receiving data, the smart card interface must be initialized as described below. Initialization is also necessary when switching from transmit mode to receive mode, or vice versa.

1. Clear the TE and RE bits to 0 in the serial control register (SCR).
2. Clear error flags FER/ERS, PER, and ORER to 0 in the serial status register (SSR).
3. Set the parity bit (O/\bar{E}) and baud rate generator select bits (CKS1 and CKS0) in the serial mode register (SMR). Clear the C/\bar{A} , CHR, and MP bits to 0, and set the STOP and PE bits to 1.
4. Set the SMIF, SDIR, and SINV bits in the smart card mode register (SCMR).
When the SMIF bit is set to 1, the TxD pin and RxD pin are both switched from port to SCI pin functions and go to the high-impedance state.
5. Set a value corresponding to the desired bit rate in the bit rate register (BRR).
6. Set the CKE0 bit in SCR. Clear the TIE, RIE, TE, RE, MPIE, TEIE, and CKE1 bits to 0. If the CKE0 bit is set to 1, the clock is output from the SCK pin.
7. Wait at least one bit interval, then set the TIE, RIE, TE, and RE bits in SCR. Do not set the TE bit and RE bit at the same time, except for self-diagnosis.

Transmitting Serial Data: As data transmission in smart card mode involves error signal sampling and retransmission processing, the processing procedure is different from that for the normal SCI. Figure 14.5 shows a sample transmission processing flowchart.

1. Perform smart card interface mode initialization as described in Initialization above.
2. Check that the ERS error flag is cleared to 0 in SSR.
3. Repeat steps 2 and 3 until it can be confirmed that the TEND flag is set to 1 in SSR.
4. Write the transmit data in TDR, clear the TDRE flag to 0, and perform the transmit operation.
The TEND flag is cleared to 0.
5. To continue transmitting data, go back to step 2.
6. To end transmission, clear the TE bit to 0.

The above processing may include interrupt handling DMA transfer.

If transmission ends and the TEND flag is set to 1 while the TIE bit is set to 1 and interrupt requests are enabled, a transmit-data-empty interrupt (TXI) will be requested. If an error occurs in transmission and the ERS flag is set to 1 while the RIE bit is set to 1 and interrupt requests are enabled, a transmit/receive-error interrupt (ERI) will be requested.

The timing of TEND flag setting depends on the GM bit in SMR (see figure 14.4).

If the TXI interrupt activates the DMAC, the number of bytes designated in the DMAC can be transmitted automatically, including automatic retransmission.

For details, see Interrupt Operations and Data Transfer by DMAC in this section.

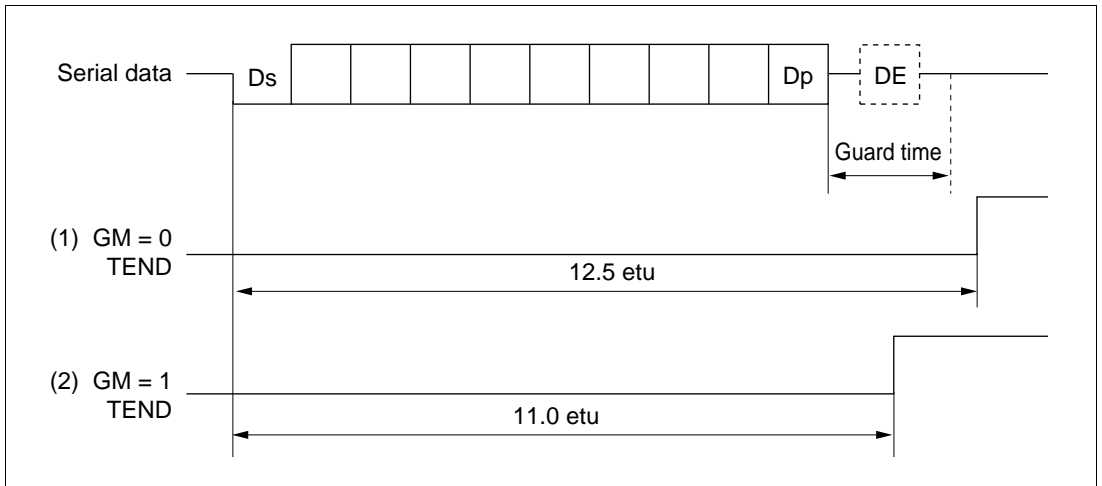

Figure 14.4 Timing of TEND Flag Setting

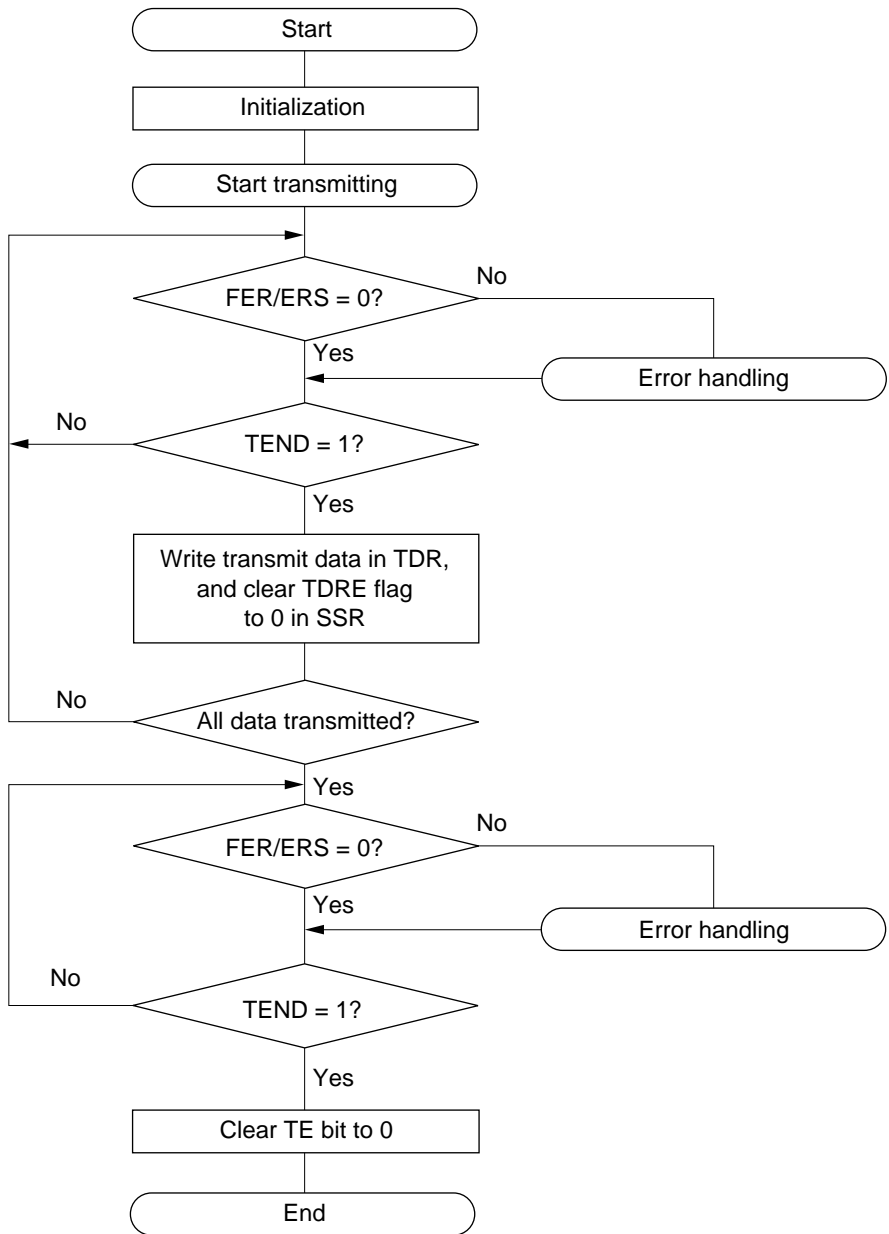

Figure 14.5 Sample Transmission Processing Flowchart

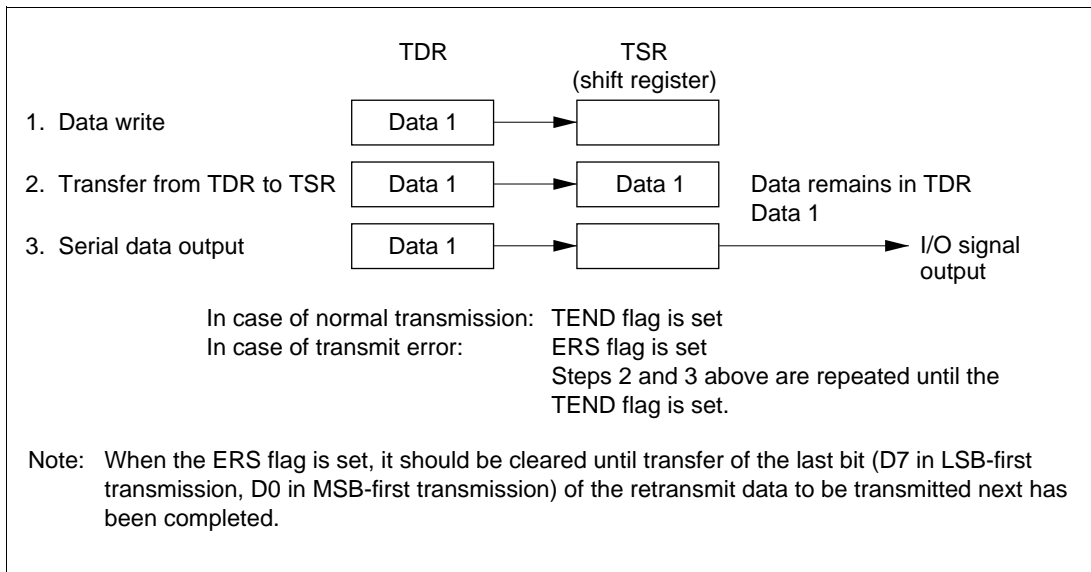

Figure 14.6 Relation Between Transmit Operation and Internal Registers

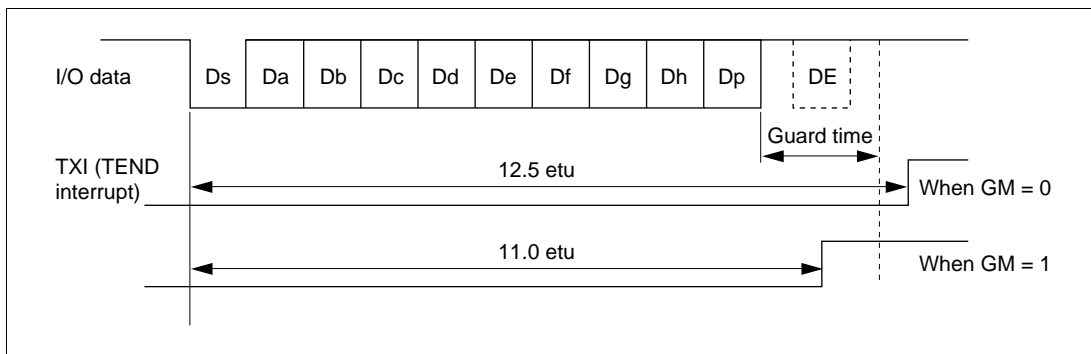

Figure 14.7 Timing of TEND Flag Setting

Receiving Serial Data: Data reception in smart card mode uses the same processing procedure as for the normal SCI. Figure 14.8 shows a sample reception processing flowchart.

1. Perform smart card interface mode initialization as described in Initialization above.
2. Check that the ORER flag and PER flag are cleared to 0 in SSR. If either is set, perform the appropriate receive error handling, then clear both the ORER and the PER flag to 0.
3. Repeat steps 2 and 3 until it can be confirmed that the RDRF flag is set to 1.
4. Read the receive data from RDR.
5. To continue receiving data, clear the RDRF flag to 0 and go back to step 2.
6. To end reception, clear the RE bit to 0.

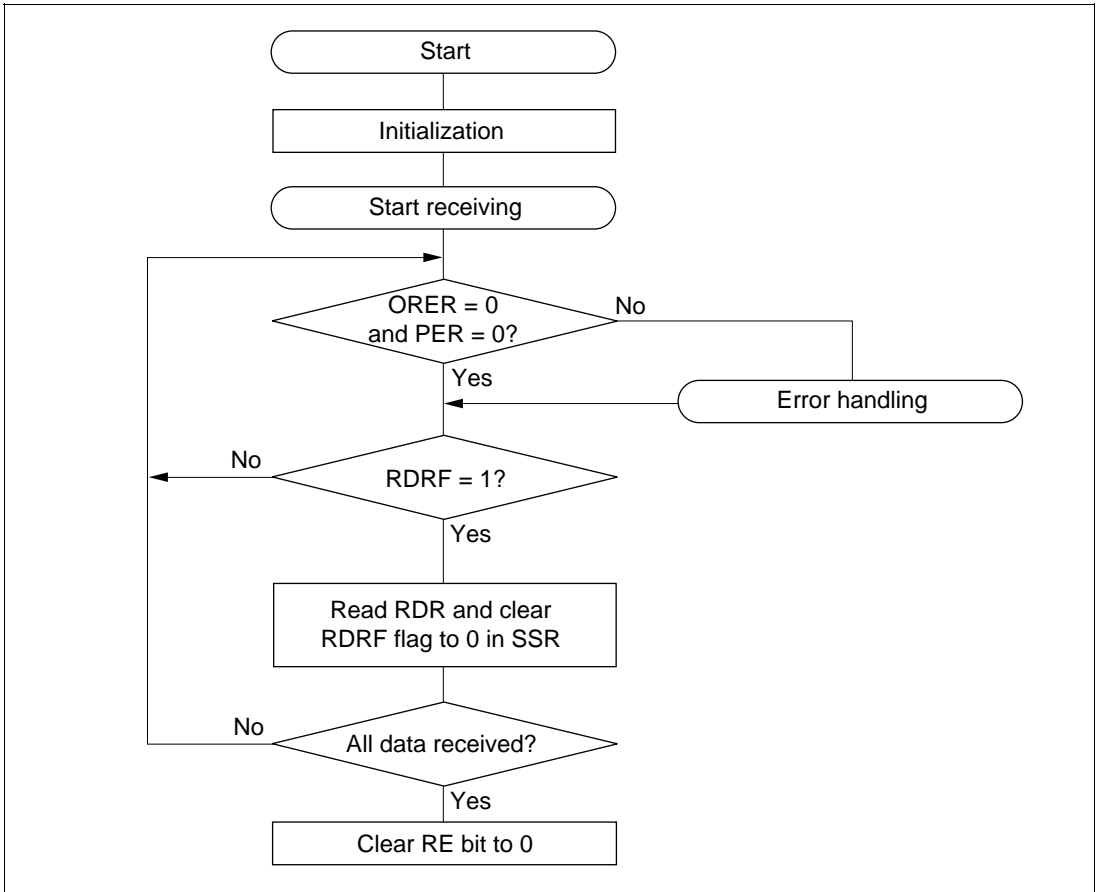

Figure 14.8 Sample Reception Processing Flowchart

The above procedure may include interrupt handling and DMA transfer.

If reception ends and the RDRF flag is set to 1 while the RIE bit is set to 1 and interrupt requests are enabled, a receive-data-full interrupt (RXI) will be requested. If an error occurs in reception and either the ORER flag or the PER flag is set to 1, a transmit/receive-error interrupt (ERI) will be requested.

If the RXI interrupt activates the DMAC, the number of bytes designated in the DMAC will be transferred, skipping receive data in which an error occurred.

For details, see Interrupt Operations and Data Transfer by DMAC in this section.

If a parity error occurs during reception and the PER flag is set to 1, the received data is transferred to RDR, so the erroneous data can be read.

Switching Modes: When switching from receive mode to transmit mode, first confirm that the receive operation has been completed, then start from initialization, clearing RE to 0 and setting TE to 1. The RDRF, PER, or ORER flag can be used to check that the receive operation has been completed.

When switching from transmit mode to receive mode, first confirm that the transmit operation has been completed, then start from initialization, clearing TE to 0 and setting RE to 1. The TEND flag can be used to check that the transmit operation has been completed.

Fixing Clock Output: When the GM bit is set to 1 in SMR, clock output can be fixed by means of the CKE1 and CKE0 bits in SCR. The minimum clock pulse width can be set to the specified width in this case.

Figure 14.9 shows the timing for fixing clock output. In this example, GM = 1, CKE1 = 0, and the CKE0 bit is controlled.

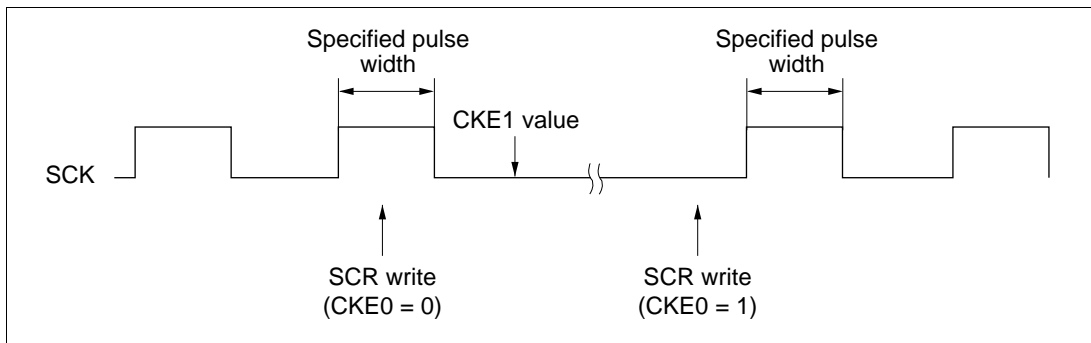

Figure 14.9 Timing for Fixing Clock Output

Interrupt Operations: The smart card interface has three interrupt sources: transmit-data-empty (TXI), transmit/receive-error (ERI), and receive-data-full (RXI). The transmit-end interrupt request (TEI) is not available in smart card mode.

A TXI interrupt is requested when the TEND flag is set to 1 in SSR. An RXI interrupt is requested when the RDRF flag is set to 1 in SSR. An ERI interrupt is requested when the ORER, PER, or ERS flag is set to 1 in SSR. These relationships are shown in table 14.8.

Table 14.8 Smart Card Interface Mode Operating States and Interrupt Sources

Operating State		Flag	Enable Bit	Interrupt Source	DMAC Activation
Transmit Mode	Normal operation	TEND	TIE	TXI	Available
	Error	ERS	RIE	ERI	Not available
Receive Mode	Normal operation	RDRF	RIE	RXI	Available
	Error	PER, ORER	RIE	ERI	Not available

Data Transfer by DMAC: The DMAC can be used to transmit and receive data in smart card mode, as in normal SCI operations. In transmit mode, when the TEND flag is set to 1 in SSR, the TDRE flag is set simultaneously, generating a TXI interrupt. If the TXI request is designated beforehand as a DMAC activation source, the DMAC will be activated by the TXI request and will transfer the next transmit data. This data transfer by the DMAC automatically clears the TDRE and TEND flags to 0. In the event of an error, the SCI automatically retransmits the same data, keeping the TEND flag cleared to 0 so that the DMAC is not activated. The SCI and DMAC will therefore automatically transmit the designated number of bytes, including retransmission when an error occurs. When an error occurs, the ERS flag is not cleared automatically, so the RIE bit should be set to 1 to enable the error to generate an ERI request, and the ERI interrupt handler should clear ERS.

When using the DMAC to transmit or receive, first set up and enable the DMAC, then make SCI settings. DMAC settings are described in section 7, DMA controller.

In receive operations, an RXI interrupt is requested when the RDRF flag is set to 1 in SSR. If the RXI request is designated beforehand as a DMAC activation source, the DMAC will be activated by the RXI request and will transfer the received data. This data transfer by the DMAC automatically clears the RDRF flag to 0. When an error occurs, the RDRF flag is not set and an error flag is set instead. The DMAC is not activated. The ERI interrupt request is directed to the CPU. The ERI interrupt handler should clear the error flags.

Examples of Operation in GSM Mode: When switching between smart card interface mode and software standby mode, use the following procedures to maintain the clock duty cycle.

- Switching from smart card interface mode to software standby mode
 1. Set the P9₄ data register (DR) and data direction register (DDR) to the values for the fixed output state in software standby mode.
 2. Write 0 in the TE and RE bits in the serial control register (SCR) to stop transmit/receive operations. At the same time, set the CKE1 bit to the value for the fixed output state in software standby mode.
 3. Write 0 in the CKE0 bit in SCR to stop the clock.
 4. Wait for one serial clock cycle. During this period, the duty cycle is preserved and clock output is fixed at the specified level.
 5. Write H'00 in the serial mode register (SMR) and smart card mode register (SCMR).
 6. Make the transition to the software standby state.
- Returning from software standby mode to smart card interface mode
 - 1'. Clear the software standby state.
 - 2'. Set the CKE1 bit in SCR to the value for the fixed output state at the start of software standby (the current P9₄ pin state).
 - 3'. Set smart card interface mode and output the clock. Clock signal generation is started with the normal duty cycle.

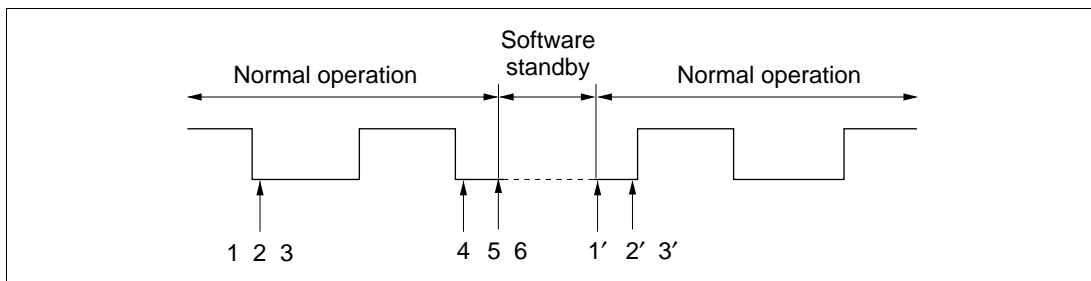

Figure 14.10 Procedure for Stopping and Restarting the Clock

Use the following procedure to secure the clock duty cycle after powering on.

1. The initial state is port input and high impedance. Use pull-up or pull-down resistors to fix the potential.
2. Fix at the output specified by the CKE1 bit in SCR.
3. Set SMR and SCMR, and switch to smart card interface mode operation.
4. Set the CKE0 bit to 1 in SCR to start clock output.

14.4 Usage Notes

The following points should be noted when using the SCI as a smart card interface.

Receive Data Sampling Timing and Receive Margin in Smart Card Interface Mode: In smart card interface mode, the SCI operates on a base clock with a frequency of 372 times the transfer rate. In reception, the SCI synchronizes internally with the fall of the start bit, which it samples on the base clock. Receive data is latched at the rising edge of the 186th base clock pulse. The timing is shown in figure 14.11.

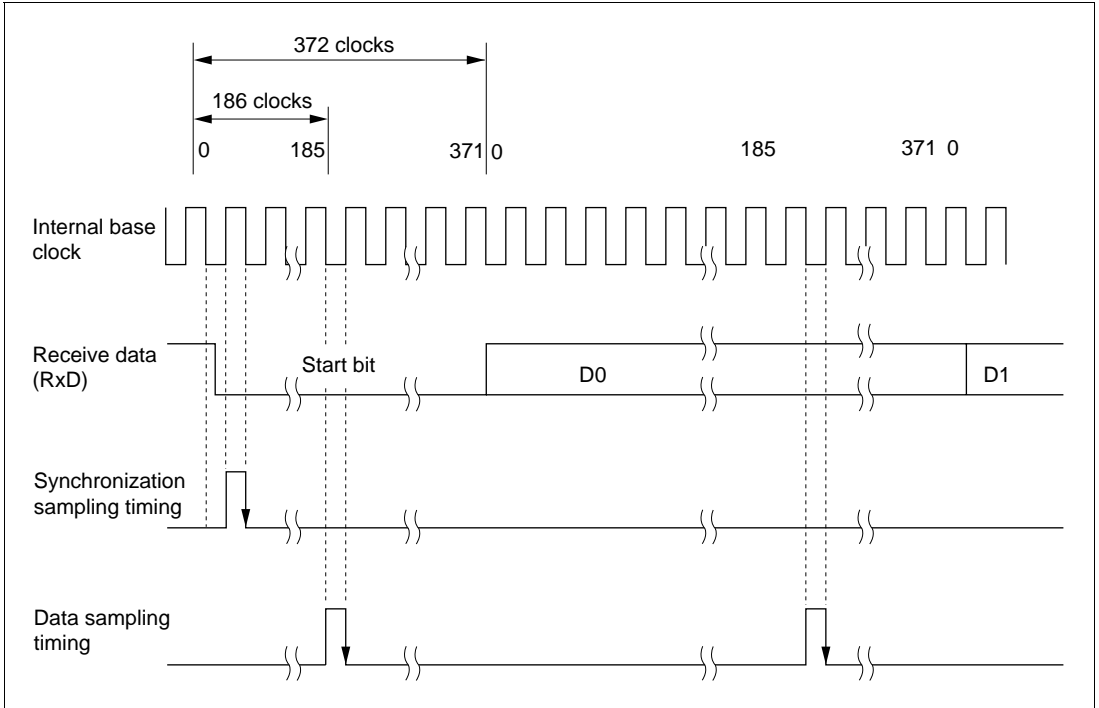

Figure 14.11 Receive Data Sampling Timing in Smart Card Interface Mode

The receive margin can therefore be expressed as follows.

Receive margin in smart card interface mode:

$$M = \left| \left(0.5 - \frac{1}{2N} \right) - (L - 0.5) F - \frac{|D - 0.5|}{N} (1 + F) \right| \times 100\%$$

M: Receive margin (%)

N: Ratio of clock frequency to bit rate (N = 372)

D: Clock duty cycle (L = 0 to 1.0)

L: Frame length (L = 10)

F: Absolute deviation of clock frequency

From the above equation, if $F = 0$ and $D = 0.5$, the receive margin is as follows.

When $D = 0.5$ and $F = 0$:

$$M = (0.5 - 1/2 \times 372) \times 100\% = 49.866\%$$

Retransmission: Retransmission is performed by the SCI in receive mode and transmit mode as described below.

- Retransmission when SCI is in Receive Mode

Figure 14.12 illustrates retransmission when the SCI is in receive mode.

- If an error is found when the received parity bit is checked, the PER bit is automatically set to 1. If the RIE bit in SCR is set to the enable state, an ERI interrupt is requested. The PER bit should be cleared to 0 in SSR before the next parity bit sampling timing.
- The RDRF bit in SSR is not set for the frame in which the error has occurred.
- If no error is found when the received parity bit is checked, the PER bit is not set to 1 in SSR.
- If no error is found when the received parity bit is checked, the receive operation is assumed to have been completed normally, and the RDRF bit is automatically set to 1 in SSR. If the RIE bit in SCR is set to the enable state, an RXI interrupt is requested. If RXI is enabled as a DMA transfer activation source, the RDR contents can be read automatically. When the DMAC reads the RDR data, the RDRF flag is automatically cleared to 0.
- When a normal frame is received, the data pin is held in the high-impedance state at the error signal transmission timing.

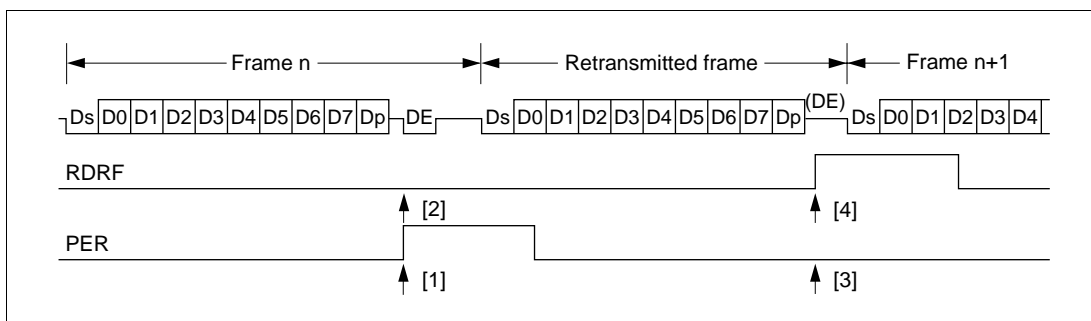

Figure 14.12 Retransmission in SCI Receive Mode

- Retransmission when SCI is in Transmit Mode

Figure 14.13 illustrates retransmission when the SCI is in transmit mode.

- If an error signal is sent back from the receiving device after transmission of one frame is completed, the ERS bit is set to 1 in SSR. If the RIE bit in SCR is set to the enable state, an

ERI interrupt is requested. The ERS bit should be cleared to 0 in SSR before the next parity bit sampling timing.

7. The TEND bit in SSR is not set for the frame for which the error signal was received.
8. If an error signal is not sent back from the receiving device, the ERS flag is not set in SSR.
9. If an error signal is not sent back from the receiving device, transmission of one frame, including retransmission, is assumed to have been completed, and the TEND bit is set to 1 in SSR. If the TIE bit in SCR is set to the enable state, a TXI interrupt is requested. If TXI is enabled as a DMA transfer activation source, the next data can be written in TDR automatically. When the DMAC writes data in TDR, the TDRE bit is automatically cleared to 0.

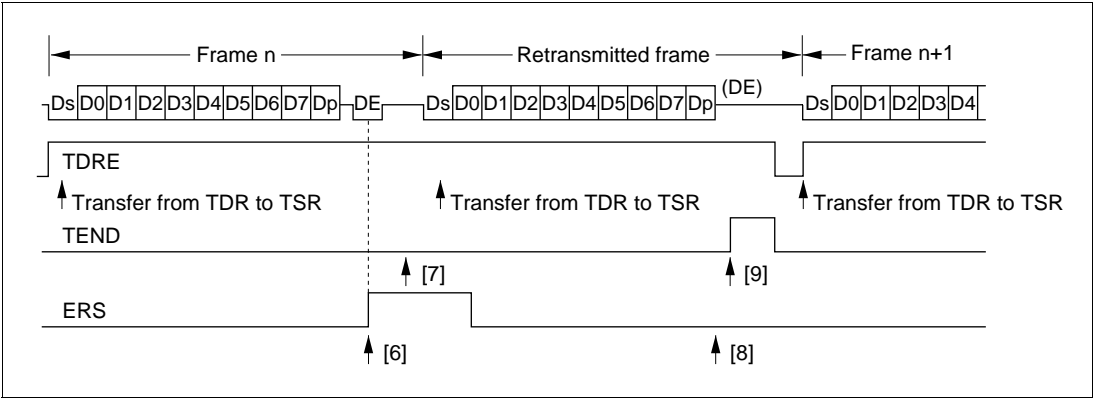

Figure 14.13 Retransmission in SCI Transmit Mode

Section 15 A/D Converter

15.1 Overview

The H8/3006 and H8/3007 includes a 10-bit successive-approximations A/D converter with a selection of up to eight analog input channels.

When the A/D converter is not used, it can be halted independently to conserve power. For details see section 19.6, Module Standby Function.

15.1.1 Features

A/D converter features are listed below.

- 10-bit resolution
- Eight input channels
- Selectable analog conversion voltage range
The analog voltage conversion range can be programmed by input of an analog reference voltage at the V_{REF} pin.
- High-speed conversion
Conversion time: maximum 3.5 μ s per channel (with 20 MHz system clock)
- Two conversion modes
Single mode: A/D conversion of one channel
Scan mode: continuous conversion on one to four channels
- Four 16-bit data registers
A/D conversion results are transferred for storage into data registers corresponding to the channels.
- Sample-and-hold function
- Three conversion start sources
The A/D converter can be activated by software, an external trigger, or an 8-bit timer compare match.
- A/D interrupt requested at end of conversion
At the end of A/D conversion, an A/D end interrupt (ADI) can be requested.
- DMA controller (DMAC) activation
The DMAC can be activated at the end of A/D conversion.

15.1.2 Block Diagram

Figure 15.1 shows a block diagram of the A/D converter.

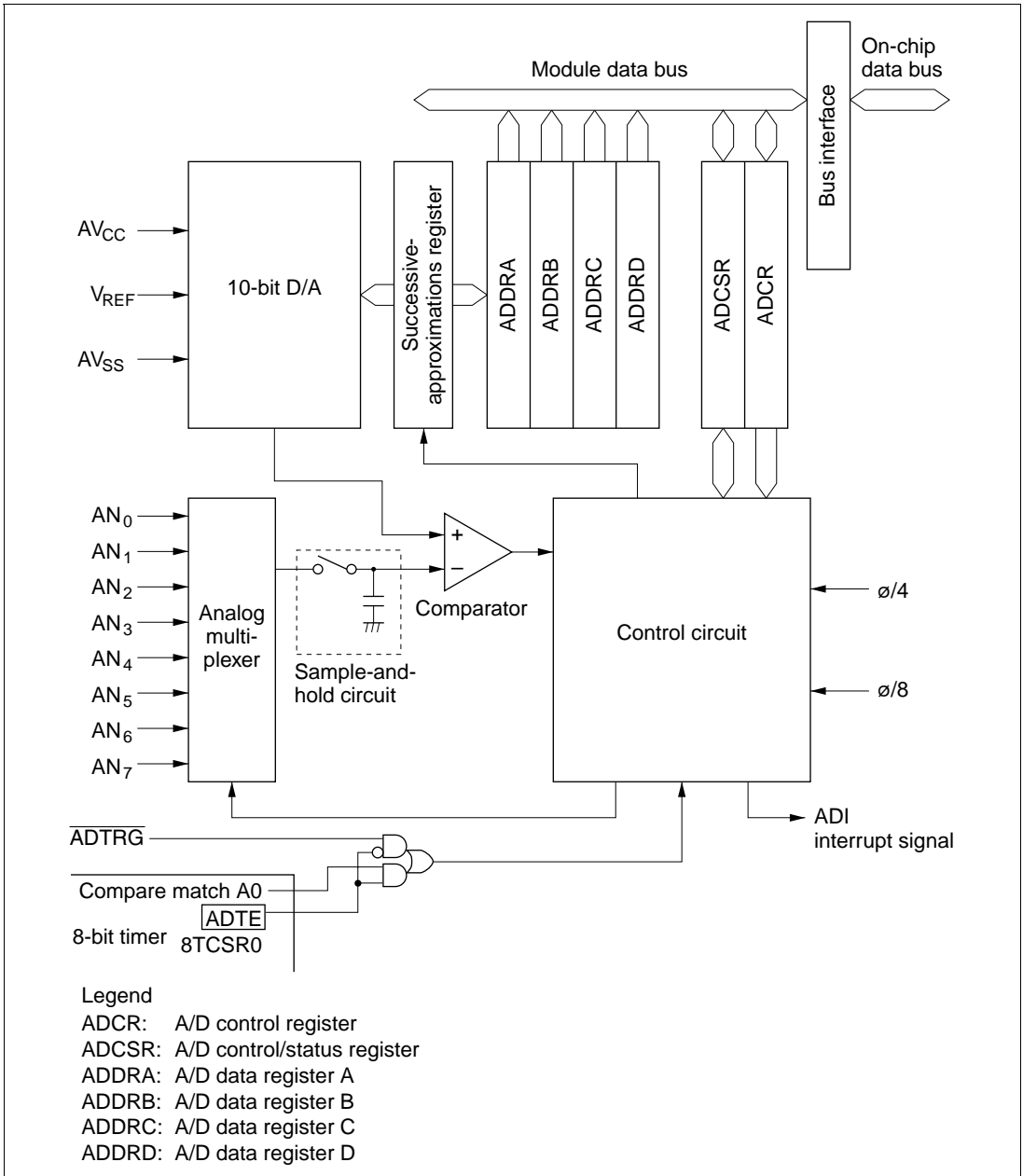

Figure 15.1 A/D Converter Block Diagram

15.1.3 Pin Configuration

Table 15.1 summarizes the A/D converter's input pins. The eight analog input pins are divided into two groups: group 0 (AN_0 to AN_3), and group 1 (AN_4 to AN_7). AV_{CC} and AV_{SS} are the power supply for the analog circuits in the A/D converter. V_{REF} is the A/D conversion reference voltage.

Table 15.1 A/D Converter Pins

Pin Name	Abbreviation	I/O	Function
Analog power supply pin	AV_{CC}	Input	Analog power supply
Analog ground pin	AV_{SS}	Input	Analog ground and reference voltage
Reference voltage pin	V_{REF}	Input	Analog reference voltage
Analog input pin 0	AN_0	Input	Group 0 analog inputs
Analog input pin 1	AN_1	Input	
Analog input pin 2	AN_2	Input	
Analog input pin 3	AN_3	Input	
Analog input pin 4	AN_4	Input	Group 1 analog inputs
Analog input pin 5	AN_5	Input	
Analog input pin 6	AN_6	Input	
Analog input pin 7	AN_7	Input	
A/D external trigger input pin	\overline{ADTRG}	Input	External trigger input for starting A/D conversion

15.1.4 Register Configuration

Table 15.2 summarizes the A/D converter's registers.

Table 15.2 A/D Converter Registers

Address*1	Name	Abbreviation	R/W	Initial Value
H'FFFE0	A/D data register AH	ADDRAH	R	H'00
H'FFFE1	A/D data register AL	ADDRAL	R	H'00
H'FFFE2	A/D data register BH	ADDRBH	R	H'00
H'FFFE3	A/D data register BL	ADDRBL	R	H'00
H'FFFE4	A/D data register CH	ADDRCH	R	H'00
H'FFFE5	A/D data register CL	ADDRCL	R	H'00
H'FFFE6	A/D data register DH	ADDRDH	R	H'00
H'FFFE7	A/D data register DL	ADDRDL	R	H'00
H'FFFE8	A/D control/status register	ADCSR	R/(W)*2	H'00
H'FFFE9	A/D control register	ADCR	R/W	H'7E

- Notes: 1. Lower 20 bits of the address in advanced mode.
2. Only 0 can be written in bit 7, to clear the flag.

15.2 Register Descriptions

15.2.1 A/D Data Registers A to D (ADDRA to ADDR D)

Bit	15	14	13	12	11	10	9	8	7	6	5	4	3	2	1	0
ADDRn	AD9	AD8	AD7	AD6	AD5	AD4	AD3	AD2	AD1	AD0	—	—	—	—	—	—
Initial value	0	0	0	0	0	0	0	0	0	0	0	0	0	0	0	0
Read/Write (n = A to D)	R	R	R	R	R	R	R	R	R	R	R	R	R	R	R	R

A/D conversion data
10-bit data giving an
A/D conversion result
Reserved bits

The four A/D data registers (ADDRA to ADDR D) are 16-bit read-only registers that store the results of A/D conversion.

An A/D conversion produces 10-bit data, which is transferred for storage into the A/D data register corresponding to the selected channel. The upper 8 bits of the result are stored in the upper byte of the A/D data register. The lower 2 bits are stored in the lower byte. Bits 5 to 0 of an A/D data register are reserved bits that are always read as 0. Table 15.3 indicates the pairings of analog input channels and A/D data registers.

The CPU can always read and write the A/D data registers. The upper byte can be read directly, but the lower byte is read through a temporary register (TEMP). For details see section 15.3, CPU Interface.

The A/D data registers are initialized to H'0000 by a reset and in standby mode.

Table 15.3 Analog Input Channels and A/D Data Registers

Analog Input Channel		A/D Data Register
Group 0	Group 1	
AN ₀	AN ₄	ADDRA
AN ₁	AN ₅	ADDRB
AN ₂	AN ₆	ADDRC
AN ₃	AN ₇	ADDRD

15.2.2 A/D Control/Status Register (ADCSR)

Bit	7	6	5	4	3	2	1	0
	ADF	ADIE	ADST	SCAN	CKS	CH2	CH1	CH0
Initial value	0	0	0	0	0	0	0	0
Read/Write	R/(W) *	R/W	R/W	R/W	R/W	R/W	R/W	R/W

A/D end flag
 Indicates end of A/D conversion

A/D interrupt enable
 Enables and disables A/D end interrupts

A/D start
 Starts or stops A/D conversion

Scan mode
 Selects single mode or scan mode

Clock select
 Selects the A/D conversion time

Channel select 2 to 0
 These bits select analog input channels

Note: * Only 0 can be written, to clear the flag.

ADCSR is an 8-bit readable/writable register that selects the mode and controls the A/D converter. ADCSR is initialized to H'00 by a reset and in standby mode.

Bit 7—A/D End Flag (ADF): Indicates the end of A/D conversion.

Bit 7

ADF	Description	
0	[Clearing condition] <ul style="list-style-type: none">• Read ADF when ADF =1, then write 0 in ADF.• DMAC activated by ADI interrupt.	(Initial value)
1	[Setting conditions] <ul style="list-style-type: none">• Single mode: A/D conversion ends• Scan mode: A/D conversion ends in all selected channels	

Bit 6—A/D Interrupt Enable (ADIE): Enables or disables the interrupt (ADI) requested at the end of A/D conversion.

Bit 6

ADIE	Description	
0	A/D end interrupt request (ADI) is disabled	(Initial value)
1	A/D end interrupt request (ADI) is enabled	

Bit 5—A/D Start (ADST): Starts or stops A/D conversion. The ADST bit remains set to 1 during A/D conversion. It can also be set to 1 by external trigger input at the $\overline{\text{ADTRG}}$ pin, or by an 8-bit timer compare match.

Bit 5

ADST	Description	
0	A/D conversion is stopped	(Initial value)
1	Single mode: A/D conversion starts; ADST is automatically cleared to 0 when conversion ends. Scan mode: A/D conversion starts and continues, cycling among the selected channels, until ADST is cleared to 0 by software, by a reset, or by a transition to standby mode.	

Bit 4—Scan Mode (SCAN): Selects single mode or scan mode. For further information on operation in these modes, see section 15.4, Operation. Clear the ADST bit to 0 before switching the conversion mode.

Bit 4 SCAN	Description	
0	Single mode	(Initial value)
1	Scan mode	

Bit 3—Clock Select (CKS): Selects the A/D conversion time. Clear the ADST bit to 0 before switching the conversion time.

Bit 3 CKS	Description	
0	Conversion time = 134 states (maximum)	(Initial value)
1	Conversion time = 70 states (maximum)	

Bits 2 to 0—Channel Select 2 to 0 (CH2 to CH0): These bits and the SCAN bit select the analog input channels. Clear the ADST bit to 0 before changing the channel selection.

Group Selection CH2	Channel Selection		Description	
	CH1	CH0	Single Mode	Scan Mode
0	0	0	AN ₀ (Initial value)	AN ₀
		1	AN ₁	AN ₀ , AN ₁
	1	0	AN ₂	AN ₀ to AN ₂
		1	AN ₃	AN ₀ to AN ₃
1	0	0	AN ₄	AN ₄
		1	AN ₅	AN ₄ , AN ₅
	1	0	AN ₆	AN ₄ to AN ₆
		1	AN ₇	AN ₄ to AN ₇

15.2.3 A/D Control Register (ADCR)

Bit	7	6	5	4	3	2	1	0
	TRGE	—	—	—	—	—	—	—
Initial value	0	1	1	1	1	1	1	0
Read/Write	R/W	—	—	—	—	—	—	R/W

Reserved bits

Trigger enable

Enables or disables starting of A/D conversion by an external trigger or 8-bit timer compare match

ADCR is an 8-bit readable/writable register that enables or disables starting of A/D conversion by external trigger input or an 8-bit timer compare match signal. ADCR is initialized to H'7E by a reset and in standby mode.

Bit 7—Trigger Enable (TRGE): Enables or disables starting of A/D conversion by an external trigger or 8-bit timer compare match.

Bit 7

TRGE	Description
0	Starting of A/D conversion by an external trigger or 8-bit timer compare match is disabled (Initial value)
1	A/D conversion is started at the falling edge of the external trigger signal (ADTRG) or by an 8-bit timer compare match

External trigger pin and 8-bit timer selection are performed by the 8-bit timer. For details, see section 10, 8-Bit Timers.

Bits 6 to 1—Reserved: These bits cannot be modified and are always read as 1.

Bit 0—Reserved: This bit can be read or written, but should not be set to 1.

15.3 CPU Interface

ADDRA to ADDR D are 16-bit registers, but they are connected to the CPU by an 8-bit data bus. Therefore, although the upper byte can be accessed directly by the CPU, the lower byte is read through an 8-bit temporary register (TEMP).

An A/D data register is read as follows. When the upper byte is read, the upper-byte value is transferred directly to the CPU and the lower-byte value is transferred into TEMP. Next, when the lower byte is read, the TEMP contents are transferred to the CPU.

When reading an A/D data register, always read the upper byte before the lower byte. It is possible to read only the upper byte, but if only the lower byte is read, incorrect data may be obtained.

Figure 15.2 shows the data flow for access to an A/D data register.

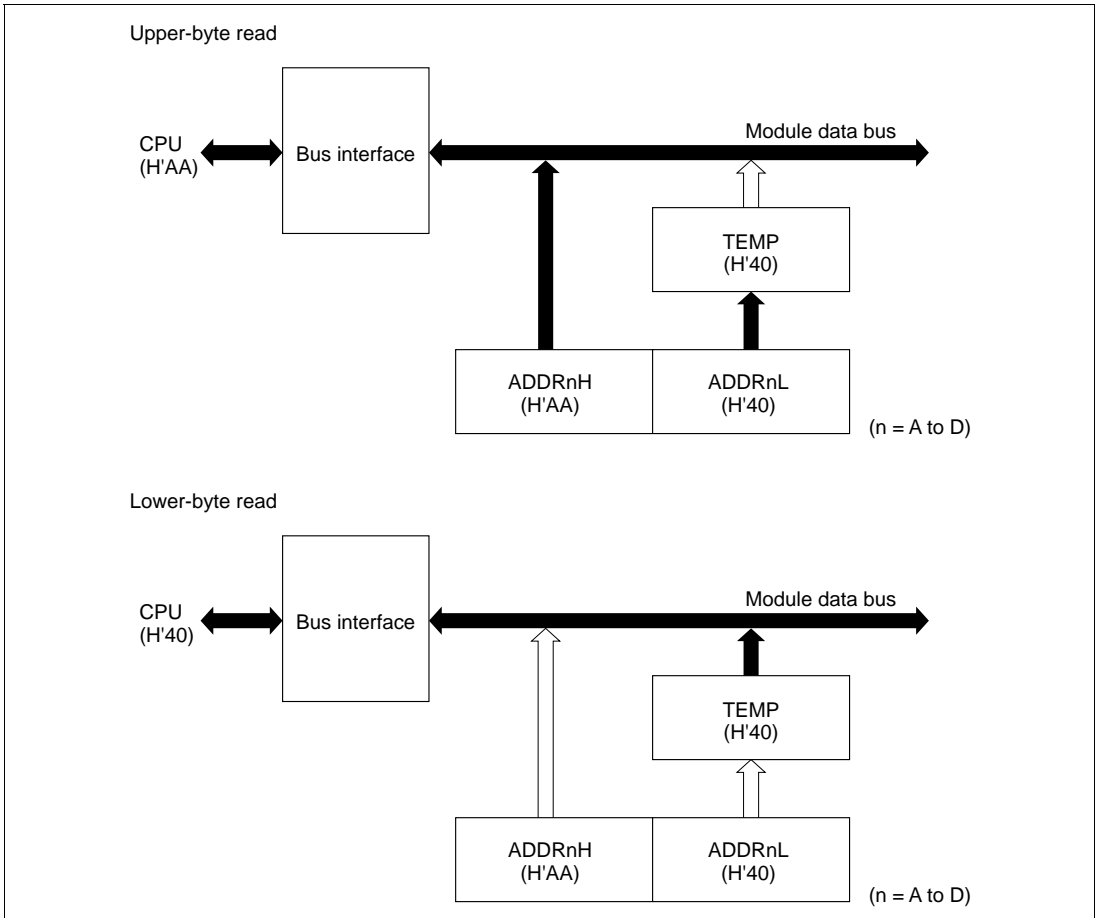

Figure 15.2 A/D Data Register Access Operation (Reading H'AA40)

15.4 Operation

The A/D converter operates by successive approximations with 10-bit resolution. It has two operating modes: single mode and scan mode.

15.4.1 Single Mode (SCAN = 0)

Single mode should be selected when only one A/D conversion on one channel is required. A/D conversion starts when the ADST bit is set to 1 by software, or by external trigger input. The ADST bit remains set to 1 during A/D conversion and is automatically cleared to 0 when conversion ends.

When conversion ends the ADF bit is set to 1. If the ADIE bit is also set to 1, an ADI interrupt is requested at this time. To clear the ADF flag to 0, first read ADCSR, then write 0 in ADF.

When the mode or analog input channel must be switched during analog conversion, to prevent incorrect operation, first clear the ADST bit to 0 in ADCSR to halt A/D conversion. After making the necessary changes, set the ADST bit to 1 to start A/D conversion again. The ADST bit can be set at the same time as the mode or channel is changed.

Typical operations when channel 1 (AN_1) is selected in single mode are described next.

Figure 15.3 shows a timing diagram for this example.

1. Single mode is selected (SCAN = 0), input channel AN_1 is selected (CH2 = CH1 = 0, CH0 = 1), the A/D interrupt is enabled (ADIE = 1), and A/D conversion is started (ADST = 1).
2. When A/D conversion is completed, the result is transferred into ADDR0. At the same time the ADF flag is set to 1, the ADST bit is cleared to 0, and the A/D converter becomes idle.
3. Since ADF = 1 and ADIE = 1, an ADI interrupt is requested.
4. The A/D interrupt handling routine starts.
5. The routine reads ADCSR, then writes 0 in the ADF flag.
6. The routine reads and processes the conversion result (ADDR0).
7. Execution of the A/D interrupt handling routine ends. After that, if the ADST bit is set to 1, A/D conversion starts again and steps 2 to 7 are repeated.

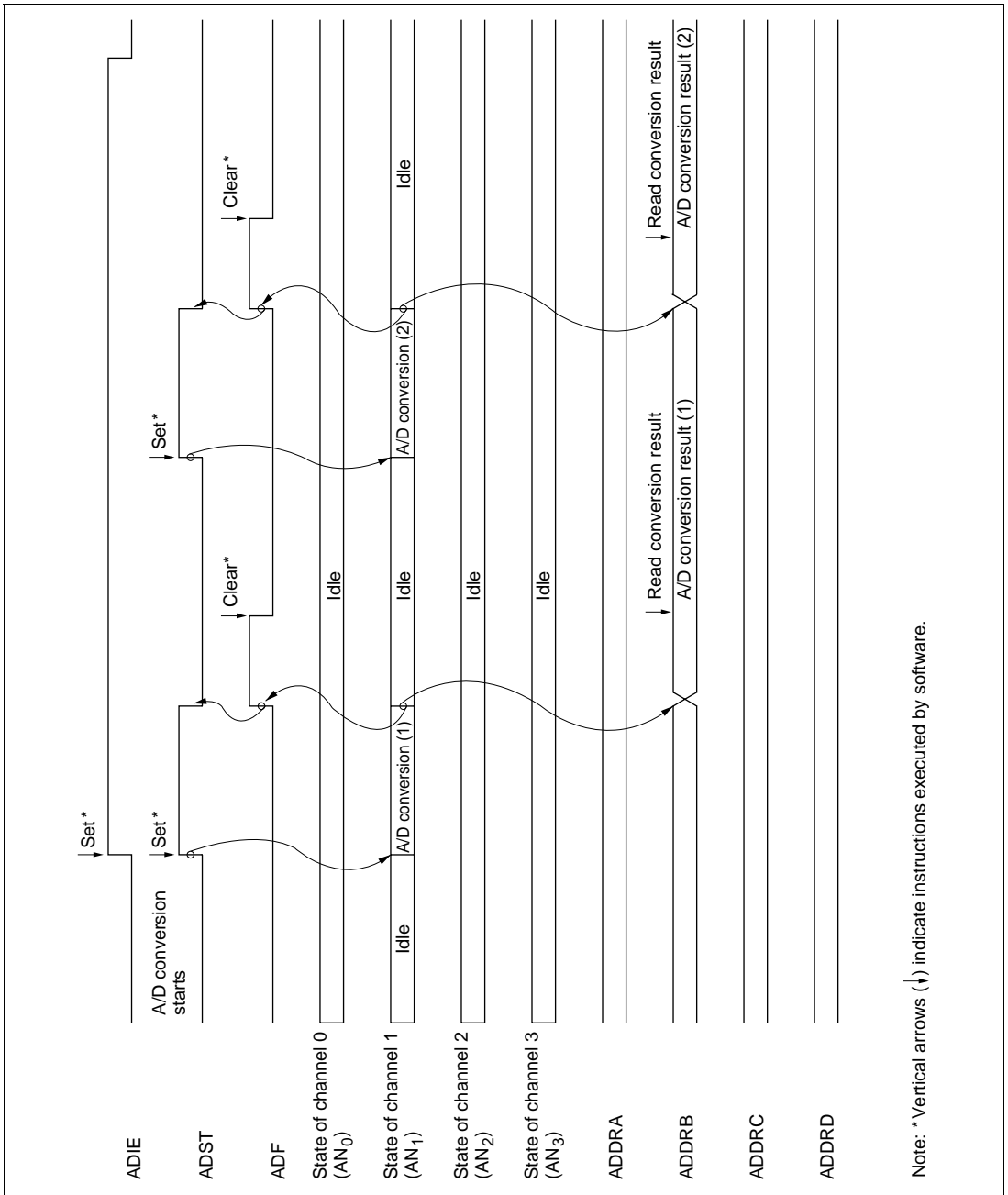

Figure 15.3 Example of A/D Converter Operation (Single Mode, Channel 1 Selected)

15.4.2 Scan Mode (SCAN = 1)

Scan mode is useful for monitoring analog inputs in a group of one or more channels. When the ADST bit is set to 1 by software or external trigger input, A/D conversion starts on the first channel in the group (AN_0 when $CH2 = 0$, AN_4 when $CH2 = 1$). When two or more channels are selected, after conversion of the first channel ends, conversion of the second channel (AN_1 or AN_5) starts immediately. A/D conversion continues cyclically on the selected channels until the ADST bit is cleared to 0. The conversion results are transferred for storage into the A/D data registers corresponding to the channels.

When the mode or analog input channel selection must be changed during analog conversion, to prevent incorrect operation, first clear the ADST bit to 0 in ADCSR to halt A/D conversion. After making the necessary changes, set the ADST bit to 1. A/D conversion will start again from the first channel in the group. The ADST bit can be set at the same time as the mode or channel selection is changed.

Typical operations when three channels in group 0 (AN_0 to AN_2) are selected in scan mode are described next. Figure 15.4 shows a timing diagram for this example.

1. Scan mode is selected ($SCAN = 1$), scan group 0 is selected ($CH2 = 0$), analog input channels AN_0 to AN_2 are selected ($CH1 = 1$, $CH0 = 0$), and A/D conversion is started ($ADST = 1$).
2. When A/D conversion of the first channel (AN_0) is completed, the result is transferred into ADDRA. Next, conversion of the second channel (AN_1) starts automatically.
3. Conversion proceeds in the same way through the third channel (AN_2).
4. When conversion of all selected channels (AN_0 to AN_2) is completed, the ADF flag is set to 1 and conversion of the first channel (AN_0) starts again. If the ADIE bit is set to 1, an ADI interrupt is requested at this time.
5. Steps 2 to 4 are repeated as long as the ADST bit remains set to 1. When the ADST bit is cleared to 0, A/D conversion stops. After that, if the ADST bit is set to 1, A/D conversion starts again from the first channel (AN_0).

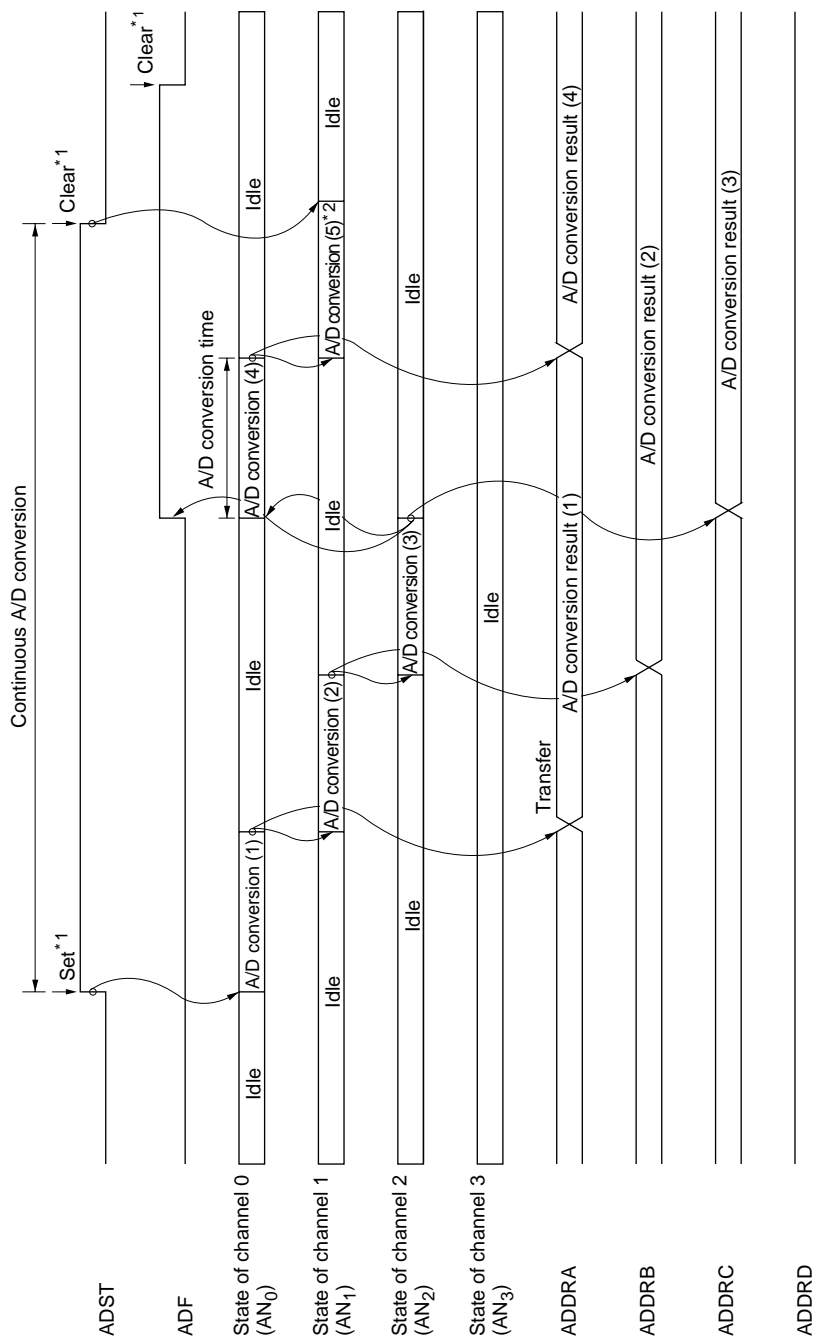

Notes: 1. Vertical arrows (↓) indicate instructions executed by software.
 2. Data currently being converted is ignored.

Figure 15.4 Example of A/D Converter Operation (Scan Mode, Channels 3 AN₀ to AN₂ Selected)

15.4.3 Input Sampling and A/D Conversion Time

The A/D converter has a built-in sample-and-hold circuit. The A/D converter samples the analog input at a time t_D after the ADST bit is set to 1, then starts conversion. Figure 15.5 shows the A/D conversion timing. Table 15.4 indicates the A/D conversion time.

As indicated in figure 15.5, the A/D conversion time includes t_D and the input sampling time. The length of t_D varies depending on the timing of the write access to ADCSR. The total conversion time therefore varies within the ranges indicated in table 15.4.

In scan mode, the values given in table 15.4 apply to the first conversion. In the second and subsequent conversions the conversion time is fixed at 128 states when $CKS = 0$ or 66 states when $CKS = 1$.

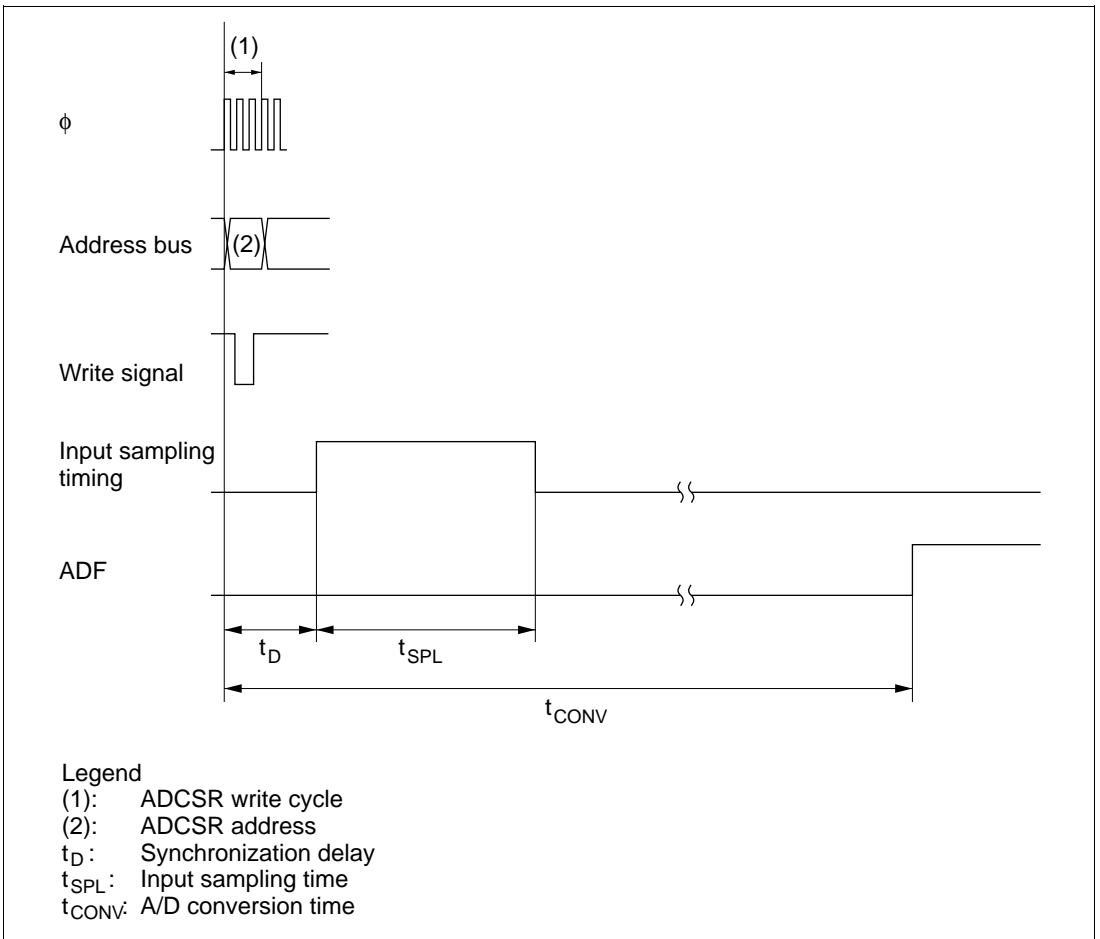

Figure 15.5 A/D Conversion Timing

Table 15.4 A/D Conversion Time (Single Mode)

	Symbol	CKS = 0			CKS = 1		
		Min	Typ	Max	Min	Typ	Max
Synchronization delay	t_D	6	—	9	4	—	5
Input sampling time	t_{SPL}	—	31	—	—	15	—
A/D conversion time	t_{CONV}	131	—	134	69	—	70

Note: Values in the table are numbers of states.

15.4.4 External Trigger Input Timing

A/D conversion can be externally triggered. When the TRGE bit is set to 1 in ADCR and the 8-bit timer's ADTE bit is cleared to 0, external trigger input is enabled at the \overline{ADTRG} pin. A falling edge at the \overline{ADTRG} pin sets the ADST bit to 1 in ADCSR, starting A/D conversion. Other operations, in both single and scan modes, are the same as if the ADST bit had been set to 1 by software. Figure 15.6 shows the timing.

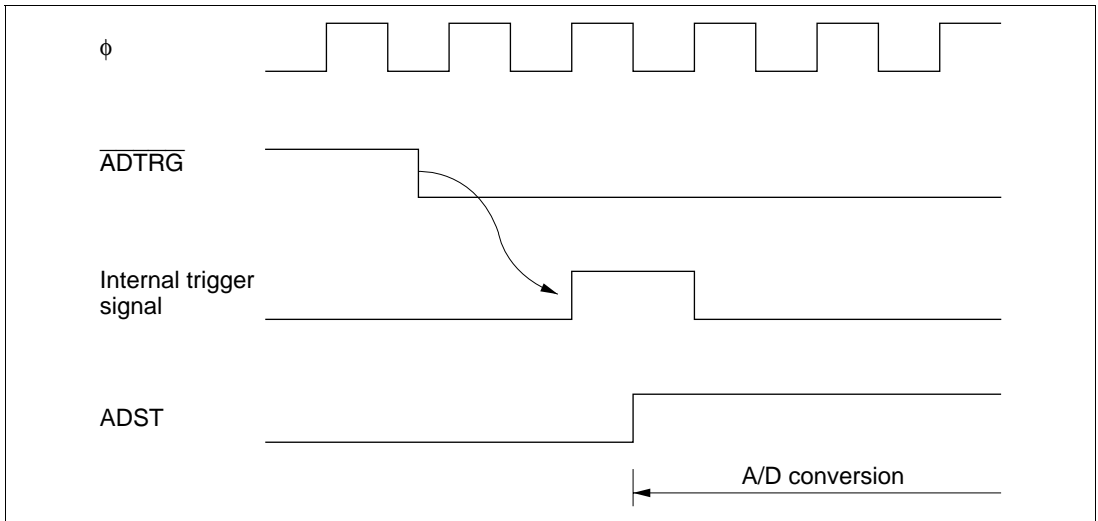

Figure 15.6 External Trigger Input Timing

15.5 Interrupts

The A/D converter generates an interrupt (ADI) at the end of A/D conversion. The ADI interrupt request can be enabled or disabled by the ADIE bit in ADCSR. The ADI interrupt request can be designated as a DMAC activation source. In this case, an interrupt request is not sent to the CPU.

15.6 Usage Notes

When using the A/D converter, note the following points:

1. Analog Input Voltage Range: During A/D conversion, the voltages input to the analog input pins should be in the range $AV_{SS} \leq AN_n \leq V_{REF}$.
2. Relationships of AV_{CC} and AV_{SS} to V_{CC} and V_{SS} : AV_{CC} , AV_{SS} , V_{CC} , and V_{SS} should be related as follows: $AV_{SS} = V_{SS}$. AV_{CC} and AV_{SS} must not be left open, even if the A/D converter is not used.
3. V_{REF} Programming Range: The reference voltage input at the V_{REF} pin should be in the range $V_{REF} \leq AV_{CC}$.
4. Note on Board Design: In board layout, separate the digital circuits from the analog circuits as much as possible. Particularly avoid layouts in which the signal lines of digital circuits cross or closely approach the signal lines of analog circuits. Induction and other effects may cause the analog circuits to operate incorrectly, or may adversely affect the accuracy of A/D conversion.

The analog input signals (AN_0 to AN_7), analog reference voltage (V_{REF}), and analog supply voltage (AV_{CC}) must be separated from digital circuits by the analog ground (AV_{SS}). The analog ground (AV_{SS}) should be connected to a stable digital ground (V_{SS}) at one point on the board.

5. Note on Noise: To prevent damage from surges and other abnormal voltages at the analog input pins (AN_0 to AN_7) and analog reference voltage pin (V_{REF}), connect a protection circuit like the one in figure 15.7 between AV_{CC} and AV_{SS} . The bypass capacitors connected to AV_{CC} and V_{REF} and the filter capacitors connected to AN_0 to AN_7 must be connected to AV_{SS} . If filter capacitors like the ones in figure 15.7 are connected, the voltage values input to the analog input pins (AN_0 to AN_7) will be smoothed, which may give rise to error. Error can also occur if A/D conversion is frequently performed in scan mode so that the current that charges and discharges the capacitor in the sample-and-hold circuit of the A/D converter becomes greater than that input to the analog input pins via input impedance R_{in} . The circuit constants should therefore be selected carefully.

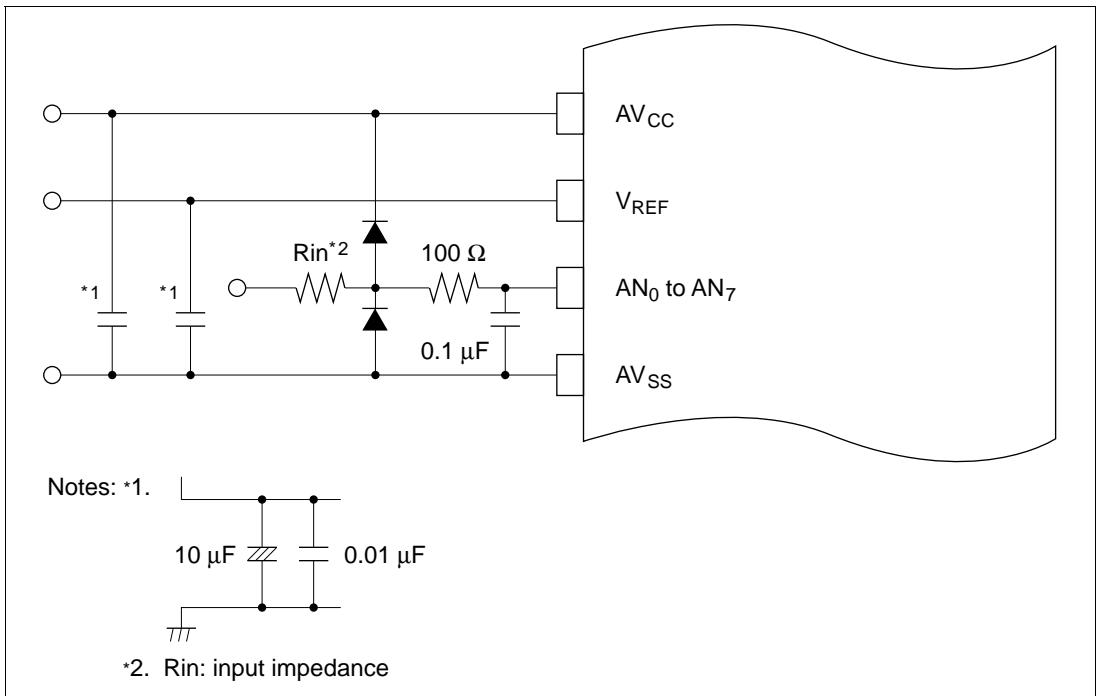

Figure 15.7 Example of Analog Input Protection Circuit

Table 15.5 Analog Input Pin Ratings

Item	min	max	Unit
Analog input capacitance	—	20	pF
Allowable signal-source impedance	—	10^*	k Ω

Note: * When conversion time 134 states, $V_{CC} = 4.0\ \text{V}$ to $5.5\ \text{V}$ and $\phi \leq 13\ \text{MHz}$. For details see section 20, Electrical Characteristics.

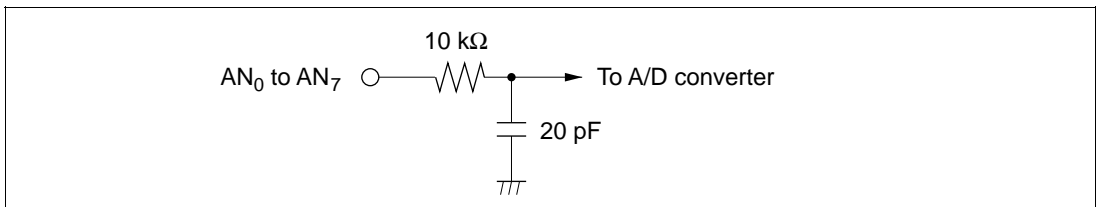

Figure 15.8 Analog Input Pin Equivalent Circuit

Note: Numeric values are approximate, except in table 15.5

6. A/D Conversion Accuracy Definitions: A/D conversion accuracy in the H8/3006 and H8/3007 are defined as follows:

- Resolution: Digital output code length of A/D converter
- Offset error: Deviation from ideal A/D conversion characteristic of analog input voltage required to raise digital output from minimum voltage value 0000000000 to 0000000001 (figure 15.10)
- Full-scale error: Deviation from ideal A/D conversion characteristic of analog input voltage required to raise digital output from 1111111110 to 1111111111 (figure 15.10)
- Quantization error: Intrinsic error of the A/D converter; 1/2 LSB (figure 15.9)
- Nonlinearity error: Deviation from ideal A/D conversion characteristic in range from zero volts to full scale, exclusive of offset error, full-scale error, and quantization error.
- Absolute accuracy: Deviation of digital value from analog input value, including offset error, full-scale error, quantization error, and nonlinearity error.

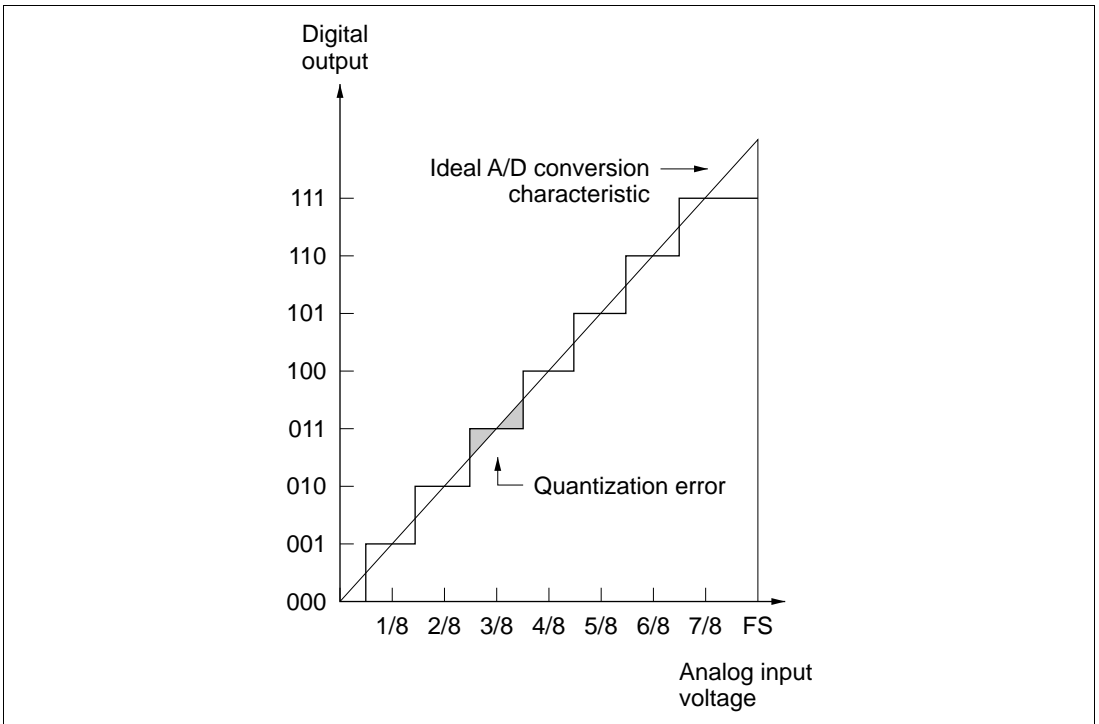

Figure 15.9 A/D Converter Accuracy Definitions (1)

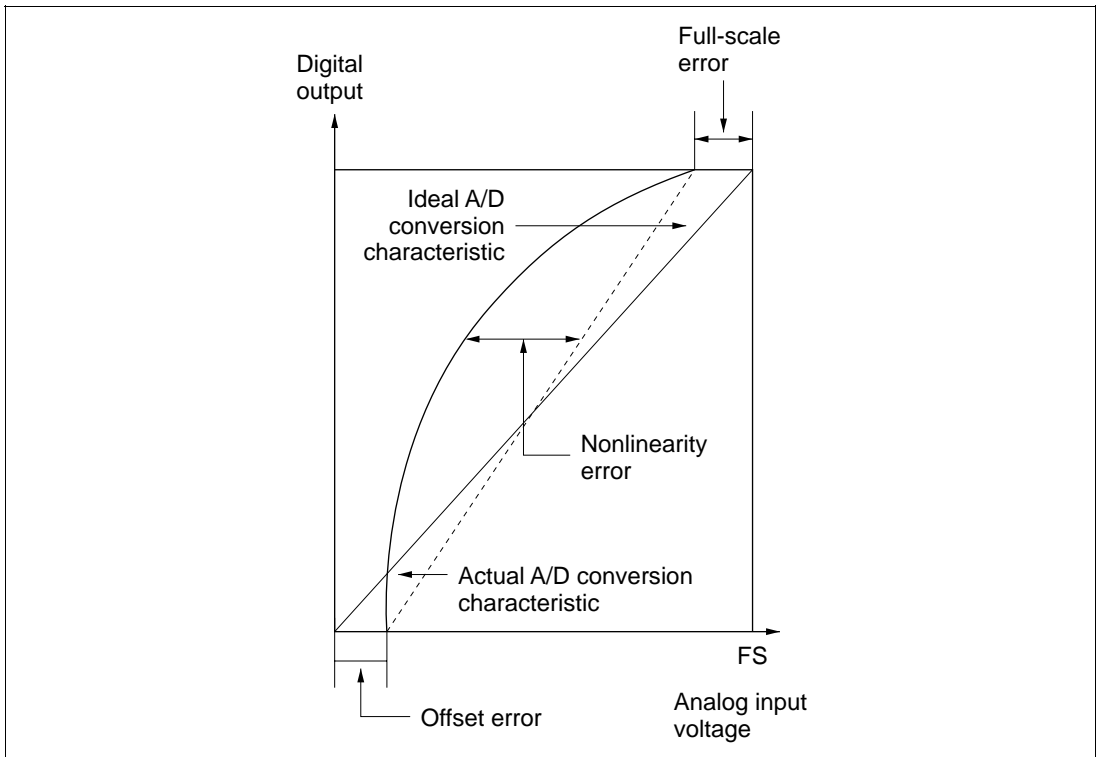

Figure 15.10 A/D Converter Accuracy Definitions (2)

7. Allowable Signal-Source Impedance: The analog inputs of the H8/3006 and H8/3007 are designed to assure accurate conversion of input signals with a signal-source impedance not exceeding 10 k Ω . The reason for this rating is that it enables the input capacitor in the sample-and-hold circuit in the A/D converter to charge within the sampling time. If the sensor output impedance exceeds 10 k Ω , charging may be inadequate and the accuracy of A/D conversion cannot be guaranteed.

If a large external capacitor is provided in single mode, then the internal 10-k Ω input resistance becomes the only significant load on the input. In this case the impedance of the signal source is not a problem.

A large external capacitor, however, acts as a low-pass filter. This may make it impossible to track analog signals with high dv/dt (e.g. a variation of 5 mV/ μ s) (figure 15.11). To convert high-speed analog signals or to use scan mode, insert a low-impedance buffer.

8. Effect on Absolute Accuracy: Attaching an external capacitor creates a coupling with ground, so if there is noise on the ground line, it may degrade absolute accuracy. The capacitor must be connected to an electrically stable ground, such as AV_{SS} .

If a filter circuit is used, be careful of interference with digital signals on the same board, and make sure the circuit does not act as an antenna.

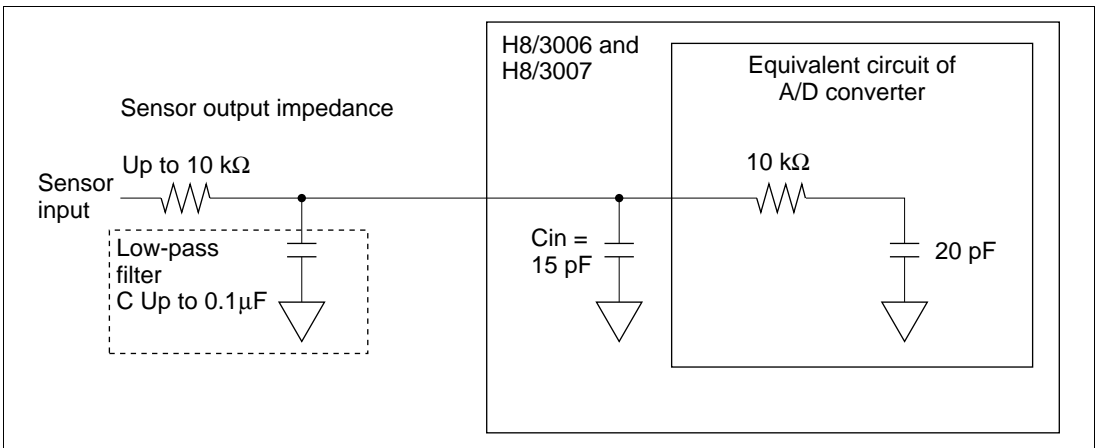

Figure 15.11 Analog Input Circuit (Example)

Section 16 D/A Converter

16.1 Overview

The H8/3006 and H8/3007 include a D/A converter with two channels.

16.1.1 Features

D/A converter features are listed below.

- Eight-bit resolution
- Two output channels
- Conversion time: maximum 10 μ s (with 20-pF capacitive load)
- Output voltage: 0 V to V_{REF}
- D/A outputs can be sustained in software standby mode

16.1.2 Block Diagram

Figure 16.1 shows a block diagram of the D/A converter.

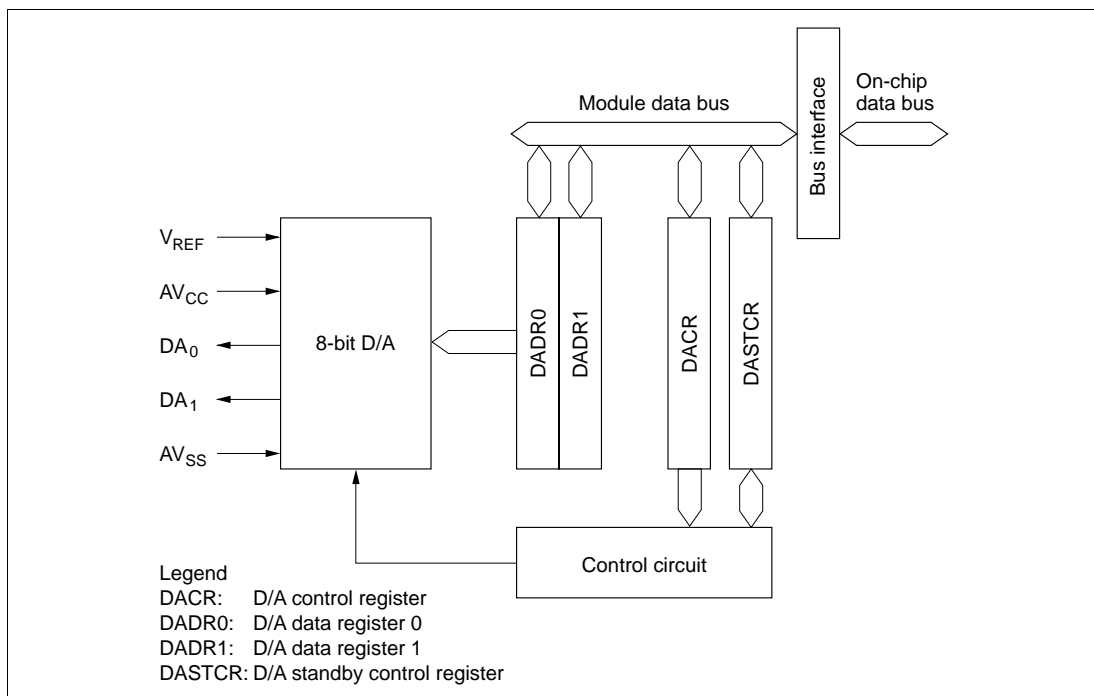

Figure 16.1 D/A Converter Block Diagram

16.1.3 Pin Configuration

Table 16.1 summarizes the D/A converter's input and output pins.

Table 16.1 D/A Converter Pins

Pin Name	Abbreviation	I/O	Function
Analog power supply pin	AV_{SS}	Input	Analog power supply and reference voltage
Analog ground pin	AV_{SS}	Input	Analog ground and reference voltage
Analog output pin 0	DA_0	Output	Analog output, channel 0
Analog output pin 1	DA_1	Output	Analog output, channel 1
Reference voltage input pin	V_{REF}	Input	Analog reference voltage

16.1.4 Register Configuration

Table 16.2 summarizes the D/A converter's registers.

Table 16.2 D/A Converter Registers

Address*	Name	Abbreviation	R/W	Initial Value
H'FFF9C	D/A data register 0	DADR0	R/W	H'00
H'FFF9D	D/A data register 1	DADR1	R/W	H'00
H'FFF9E	D/A control register	DACR	R/W	H'1F
H'EE01A	D/A standby control register	DASTCR	R/W	H'FE

Note: * Lower 20 bits of the address in advanced mode.

16.2 Register Descriptions

16.2.1 D/A Data Registers 0 and 1 (DADR0/1)

Bit	7	6	5	4	3	2	1	0
Initial value	0	0	0	0	0	0	0	0
Read/Write	R/W	R/W	R/W	R/W	R/W	R/W	R/W	R/W

The D/A data registers (DADR0 and DADR1) are 8-bit readable/writable registers that store the data to be converted. When analog output is enabled, the D/A data register values are constantly converted and output at the analog output pins.

The D/A data registers are initialized to H'00 by a reset and in standby mode.

When the DASTE bit is set to 1 in the D/A standby control register (DASTCR), the D/A registers are not initialized in software standby mode.

16.2.2 D/A Control Register (DACR)

Bit	7	6	5	4	3	2	1	0
	DAOE1	DAOE0	DAE	—	—	—	—	—
Initial value	0	0	0	1	1	1	1	1
Read/Write	R/W	R/W	R/W	—	—	—	—	—

D/A enable
Controls D/A conversion

D/A output enable 0
Controls D/A conversion and analog output

D/A output enable 1
Controls D/A conversion and analog output

DACR is an 8-bit readable/writable register that controls the operation of the D/A converter. DACR is initialized to H'1F by a reset and in standby mode.

When the DASTE bit is set to 1 in DASTCR, the DACR is not initialized in software standby mode.

Bit 7—D/A Output Enable 1 (DAOE1): Controls D/A conversion and analog output.

Bit 7

DAOE1 Description

0	DA ₁ analog output is disabled
1	Channel-1 D/A conversion and DA ₁ analog output are enabled

Bit 6—D/A Output Enable 0 (DAOE0): Controls D/A conversion and analog output.

Bit 6

DAOE0 Description

0	DA ₀ analog output is disabled
1	Channel-0 D/A conversion and DA ₀ analog output are enabled

Bit 5—D/A Enable (DAE): Controls D/A conversion, together with bits DAOE0 and DAOE1. When the DAE bit is cleared to 0, analog conversion is controlled independently in channels 0 and 1. When the DAE bit is set to 1, analog conversion is controlled together in channels 0 and 1. Output of the conversion results is always controlled independently by DAOE0 and DAOE1.

Bit 7 DAOE1	Bit 6 DAOE0	Bit 5 DAE	Description
0	0	—	D/A conversion is disabled in channels 0 and 1
	1	0	D/A conversion is enabled in channel 0 D/A conversion is disabled in channel 1
		1	D/A conversion is enabled in channels 0 and 1
1	0	0	D/A conversion is disabled in channel 0 D/A conversion is enabled in channel 1
		1	D/A conversion is enabled in channels 0 and 1
	1	—	D/A conversion is enabled in channels 0 and 1

When the DAE bit is set to 1, even if bits DAOE0 and DAOE1 in DACR and the ADST bit in ADCSR are cleared to 0, the same current is drawn from the analog power supply as during A/D and D/A conversion.

Bits 4 to 0—Reserved: These bits cannot be modified and are always read as 1.

16.2.3 D/A Standby Control Register (DASTCR)

DASTCR is an 8-bit readable/writable register that enables or disables D/A output in software standby mode.

Bit	7	6	5	4	3	2	1	0
	—	—	—	—	—	—	—	DASTE
Initial value	1	1	1	1	1	1	1	0
Read/Write	—	—	—	—	—	—	—	R/W

Reserved bits
D/A standby enable
 Enables or disables D/A output in software standby mode

DASTCR is initialized to H'FE by a reset and in hardware standby mode. It is not initialized in software standby mode.

Bits 7 to 1—Reserved: These bits cannot be modified and are always read as 1.

Bit 0—D/A Standby Enable (DASTE): Enables or disables D/A output in software standby mode.

Bit 0

DASTE	Description	
0	D/A output is disabled in software standby mode	(Initial value)
1	D/A output is enabled in software standby mode	

16.3 Operation

The D/A converter has two built-in D/A conversion circuits that can perform conversion independently.

D/A conversion is performed constantly while enabled in DACR. If the DADR0 or DADR1 value is modified, conversion of the new data begins immediately. The conversion results are output when bits DAOE0 and DAOE1 are set to 1.

An example of D/A conversion on channel 0 is given next. Timing is indicated in figure 16.2.

1. Data to be converted is written in DADR0.
2. Bit DAOE0 is set to 1 in DACR. D/A conversion starts and DA0 becomes an output pin. The converted result is output after the conversion time.

The output value is $\frac{\text{DADR contents}}{256} \times V_{\text{REF}}$

Output of this conversion result continues until the value in DADR0 is modified or the DAOE0 bit is cleared to 0.

3. If the DADR0 value is modified, conversion starts immediately, and the result is output after the conversion time.
4. When the DAOE0 bit is cleared to 0, DA0 becomes an input pin.

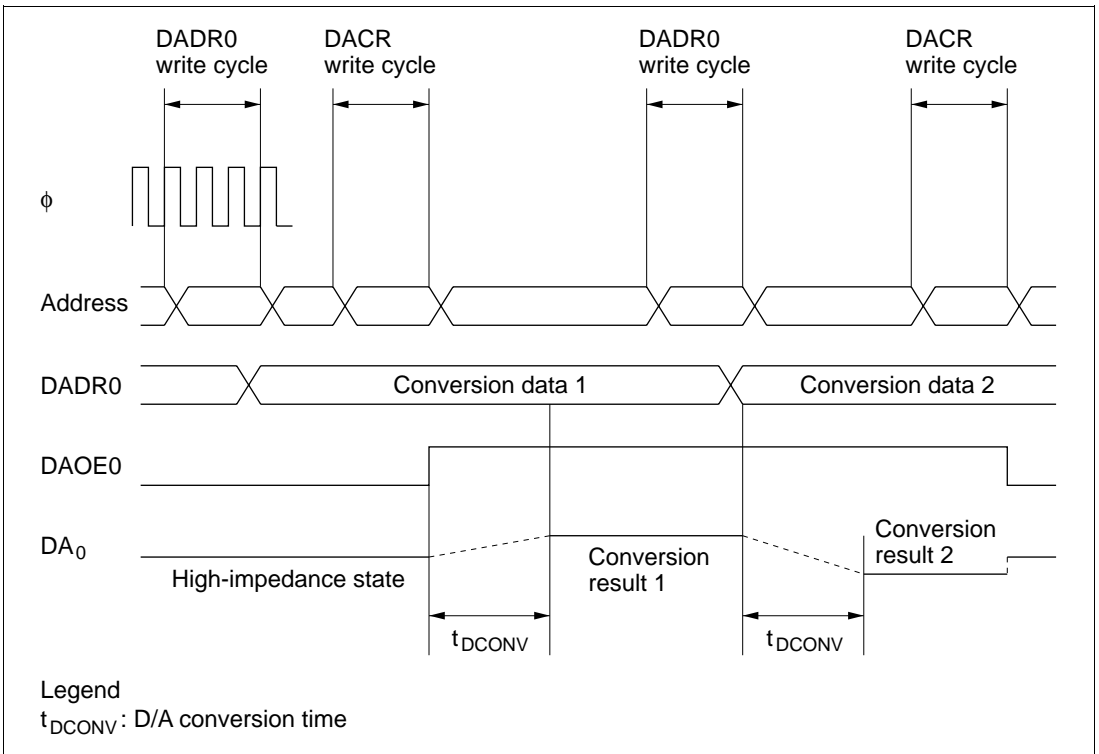

Figure 16.2 Example of D/A Converter Operation

16.4 D/A Output Control

In the H8/3006 and H8/3007, D/A converter output can be enabled or disabled in software standby mode.

When the DASTE bit is set to 1 in DASTCR, D/A converter output is enabled in software standby mode. The D/A converter registers retain the values they held prior to the transition to software standby mode.

When D/A output is enabled in software standby mode, the reference supply current is the same as during normal operation.

Section 17 RAM

17.1 Overview

The H8/3007 has 4 kbytes of high-speed static RAM on-chip. The H8/3006 has 2 kbytes. The RAM is connected to the CPU by a 16-bit data bus. The CPU accesses both byte data and word data in two states, making the RAM useful for rapid data transfer.

The on-chip RAM of the H8/3007 is assigned to addresses H'FEF20 to H'FFF1F in modes 1 and 2, and to addresses H'FFE20 to H'FFF1F in modes 3 and 4. The on-chip RAM of the H8/3006 are assigned to addresses H'FF720 to H'FFF1F in modes 1 and 2, and to addresses H'FFF720 to H'FFF1F in modes 3 and 4. The RAM enable bit (RAME) in the system control register (SYSCR) can enable or disable the on-chip RAM.

17.1.1 Block Diagram

Figure 17.1 shows a block diagram of the on-chip RAM.

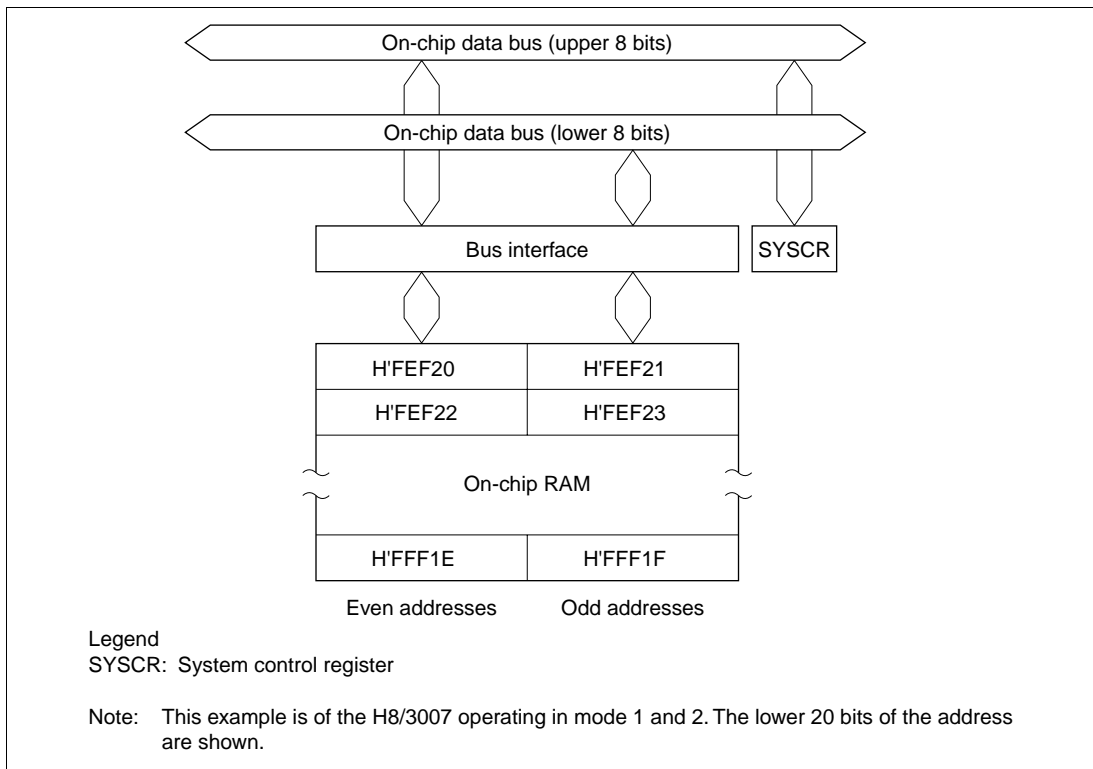

Figure 17.1 RAM Block Diagram

17.1.2 Register Configuration

The on-chip RAM is controlled by SYSCR. Table 17.1 gives the address and initial value of SYSCR.

Table 17.1 System Control Register

Address*	Name	Abbreviation	R/W	Initial Value
H'EE012	System control register	SYSCR	R/W	H'09

Note: * Lower 20 bits of the address in advanced mode.

17.2 System Control Register (SYSCR)

Bit	7	6	5	4	3	2	1	0
	SSBY	STS2	STS1	STS0	UE	NMIEG	SSOE	RAME
Initial value	0	0	0	0	1	0	0	1
Read/Write	R/W	R/W	R/W	R/W	R/W	R/W	R/W	R/W

RAM enable bit
 Enables or disables on-chip RAM

Software standby output port enable

NMI edge select

User bit enable

Standby timer select 2 to 0

Software standby

One function of SYSCR is to enable or disable access to the on-chip RAM. The on-chip RAM is enabled or disabled by the RAME bit in SYSCR. For details about the other bits, see section 3.3, System Control Register (SYSCR).

Bit 0—RAM Enable (RAME): Enables or disables the on-chip RAM. The RAME bit is initialized at the rising edge of the input at the $\overline{\text{RES}}$ pin. It is not initialized in software standby mode.

Bit 0

RAME	Description
0	On-chip RAM is disabled
1	On-chip RAM is enabled (Initial value)

17.3 Operation

When the RAME bit is set to 1, the on-chip RAM is enabled. Accesses to addresses H'FEF20 to H'FFF1F in the H8/3007 in modes 1 and 2, and to addresses H'FFE20 to H'FFF1F in the H8/3007 in modes 3 and 4, are directed to the on-chip RAM. In the H8/3006, accesses to addresses H'FF720 to H'FFF1F in modes 1 and 2, to addresses H'FFF720 to H'FFF1F in modes 3 and 4, are directed to the on-chip RAM. In modes 1 to 4, when the RAME bit is cleared to 0, the off-chip address space is accessed.

Since the on-chip RAM is connected to the CPU by an internal 16-bit data bus, it can be written and read by word access. It can also be written and read by byte access. Byte data is accessed in two states using the upper 8 bits of the data bus. Word data starting at an even address is accessed in two states using all 16 bits of the data bus.

Section 18 Clock Pulse Generator

18.1 Overview

The H8/3006 and H8/3007 have a built-in clock pulse generator (CPG) that generates the system clock (ϕ) and other internal clock signals ($\phi/2$ to $\phi/4096$). After duty adjustment, a frequency divider divides the clock frequency to generate the system clock (ϕ). The system clock is output at the ϕ pin*¹ and furnished as a master clock to prescalers that supply clock signals to the on-chip supporting modules. Frequency division ratios of 1/1, 1/2, 1/4, and 1/8 can be selected for the frequency divider by settings in a division control register (DIVCR)*². Power consumption in the chip is reduced in almost direct proportion to the frequency division ratio.

- Notes: 1. Usage of the ϕ pin differs depending on the chip operating mode and the PSTOP bit setting in the module standby control register (MSTCR). For details, see section 19.7, System Clock Output Disabling Function.
2. The division ratio of the frequency divider can be changed dynamically during operation. The clock output at the ϕ pin also changes when the division ratio is changed. The frequency output at the ϕ pin is shown below.

$$\phi = \text{EXTAL} \times n$$

where, EXTAL: Frequency of crystal resonator or external clock signal

n: Frequency division ratio ($n = 1/1, 1/2, 1/4, \text{ or } 1/8$)

18.1.1 Block Diagram

Figure 18.1 shows a block diagram of the clock pulse generator.

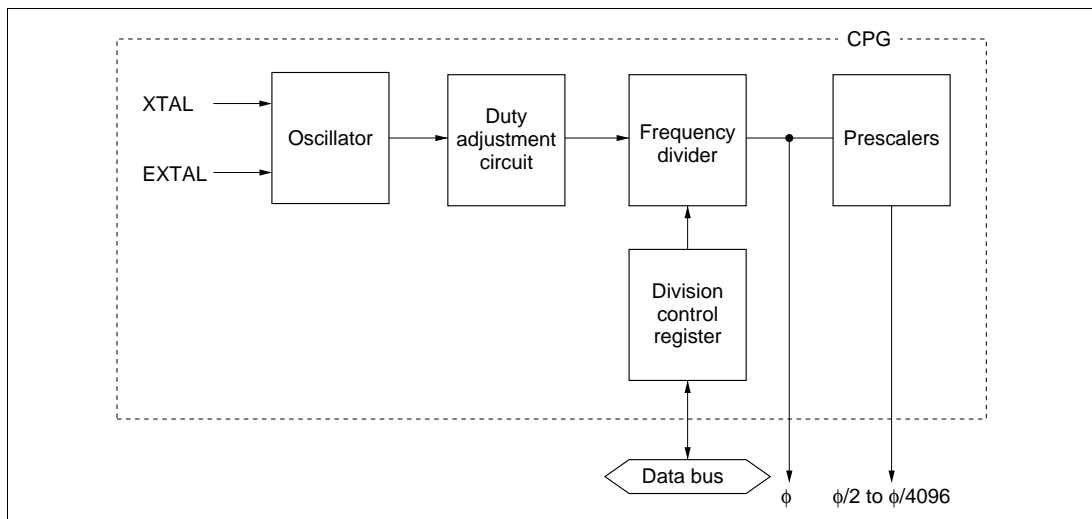

Figure 18.1 Block Diagram of Clock Pulse Generator

18.2 Oscillator Circuit

Clock pulses can be supplied by connecting a crystal resonator, or by input of an external clock signal.

18.2.1 Connecting a Crystal Resonator

Circuit Configuration: A crystal resonator can be connected as in the example in figure 18.2. The damping resistance R_d should be selected according to table 18.1. An AT-cut parallel-resonance crystal should be used.

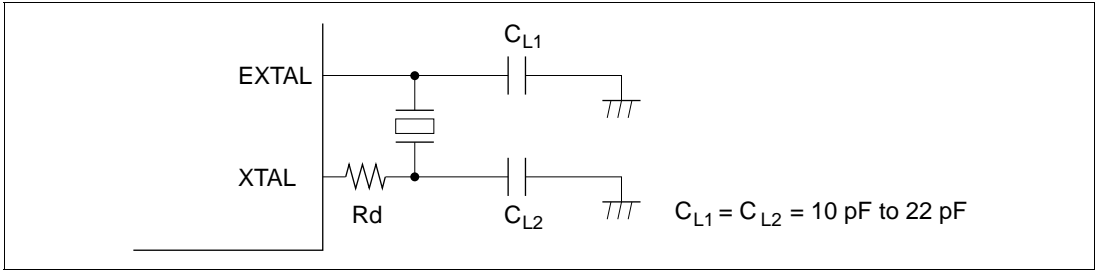

Figure 18.2 Connection of Crystal Resonator (Example)

Table 18.1 Damping Resistance Value

Damping Resistance Value	Frequency f (MHz)							
	2	$2 < f \leq 4$	$4 < f \leq 8$	$8 < f \leq 10$	$10 < f \leq 13$	$13 < f \leq 16$	$16 < f \leq 18$	$18 < f \leq 20$
R_d (Ω)	1 k	500	200	0	0	0	0	0

Note: A crystal resonator between 2 MHz and 20 MHz can be used. If the chip is to be operated at less than 2 MHz, the on-chip frequency divider should be used. (A crystal resonator of less than 2 MHz cannot be used.)

Crystal Resonator: Figure 18.3 shows an equivalent circuit of the crystal resonator. The crystal resonator should have the characteristics listed in table 18.2.

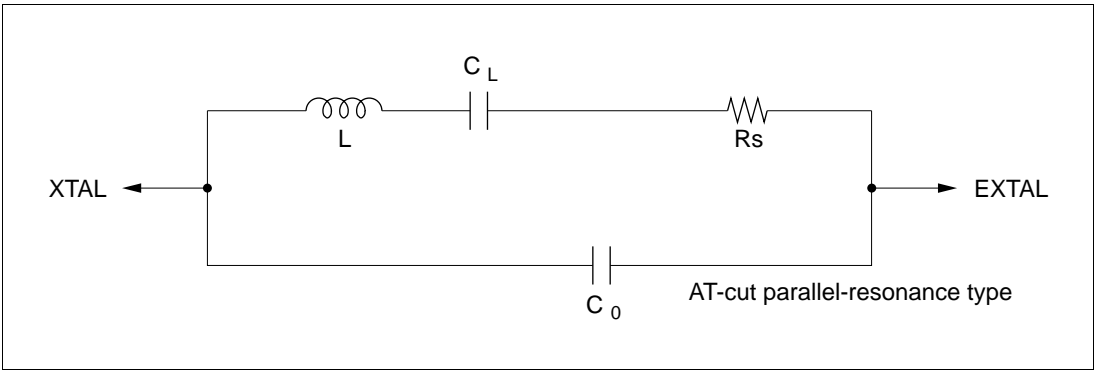

Figure 18.3 Crystal Resonator Equivalent Circuit

Table 18.2 Crystal Resonator Parameters

Frequency (MHz)	2	4	8	10	12	16	18	20
Rs max (Ω)	500	120	80	70	60	50	40	40
Co (pF)	7 pF max							

Use a crystal resonator with a frequency equal to the system clock frequency (ϕ).

Notes on Board Design: When a crystal resonator is connected, the following points should be noted:

Other signal lines should be routed away from the oscillator circuit to prevent induction from interfering with correct oscillation. See figure 18.4.

When the board is designed, the crystal resonator and its load capacitors should be placed as close as possible to the XTAL and EXTAL pins.

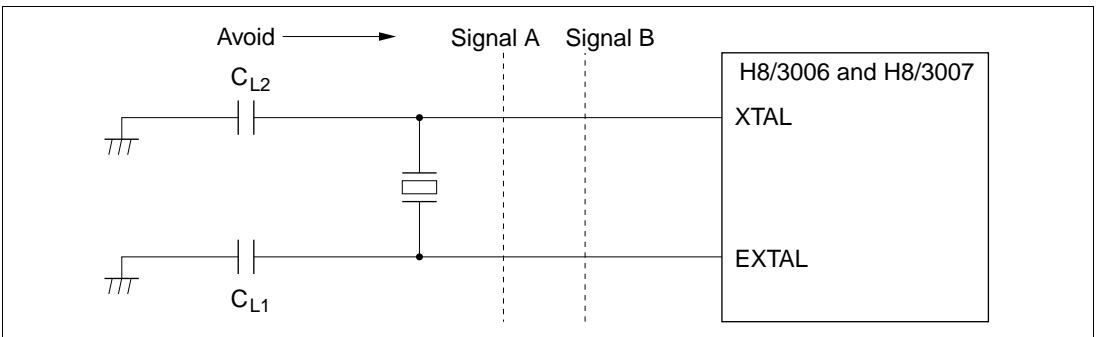

Figure 18.4 Example of Incorrect Board Design

18.2.2 External Clock Input

Circuit Configuration: An external clock signal can be input as shown in the examples in figure 18.5. If the XTAL pin is left open, the stray capacitance should not exceed 10 pF. If the stray capacitance at the XTAL pin exceeds 10 pF, use configuration b instead and hold the clock high in standby mode.

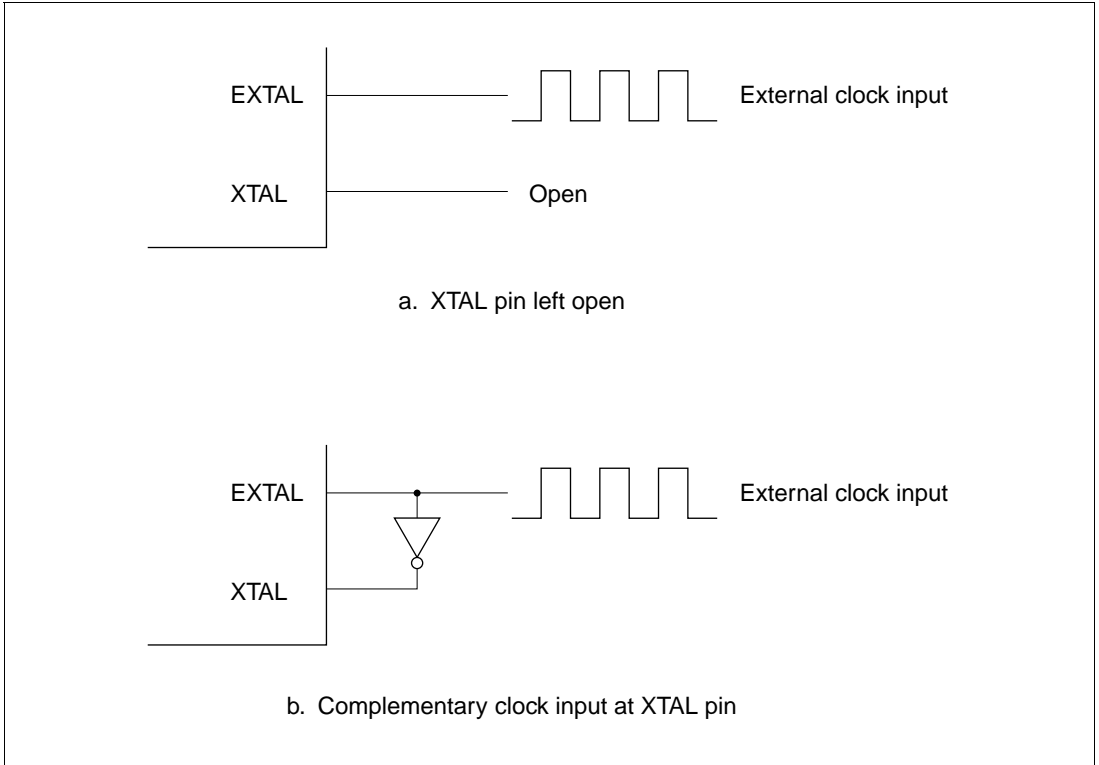

Figure 18.5 External Clock Input (Examples)

External Clock: The external clock frequency should be equal to the system clock frequency when not divided by the on-chip frequency divider. Table 18.3 shows the clock timing, figure 18.6 shows the external clock input timing, and figure 18.7 shows the external clock output settling delay timing. When the appropriate external clock is input via the EXTAL pin, its waveform is corrected by the on-chip oscillator and duty adjustment circuit.

When the appropriate external clock is input via the EXTAL pin, its waveform is corrected by the on-chip oscillator and duty adjustment circuit. The resulting stable clock is output to external devices after the external clock settling time (t_{DEXT}) has passed after the clock input. The system must remain reset with the reset signal low during t_{DEXT} , while the clock output is unstable.

Table 18.3 Clock Timing

Item	Symbol	$V_{\text{CC}} = 2.7 \text{ V}$ to 5.5 V		$V_{\text{CC}} = 3.0 \text{ V}$ to 5.5 V		$V_{\text{CC}} = 5.0 \text{ V} \pm 10\%$		Unit	Test Conditions	
		Min	Max	Min	Max	Min	Max			
External clock input low pulse width	t_{EXL}	40	—	30	—	15	—	ns	Figure 18.6	
External clock input high pulse width	t_{EXH}	40	—	30	—	15	—	ns		
External clock rise time	t_{EXr}	—	10	—	8	—	5	ns		
External clock fall time	t_{EXf}	—	10	—	8	—	5	ns		
Clock low pulse width	t_{CL}	0.4	0.6	0.4	0.6	0.4	0.6	t_{cyc}	$\phi \geq 5 \text{ MHz}$	Figure 20.3
		80	—	80	—	80	—	ns	$\phi < 5 \text{ MHz}$	
Clock high pulse width	t_{CH}	0.4	0.6	0.4	0.6	0.4	0.6	t_{cyc}	$\phi \geq 5 \text{ MHz}$	
		80	—	80	—	80	—	ns	$\phi < 5 \text{ MHz}$	
External clock output settling delay time	t_{DEXT}^*	500	—	500	—	500	—	μs	Figure 18.7	

Note: * t_{DEXT} includes a 10 t_{cyc} of RES pulse width (t_{RESW}).

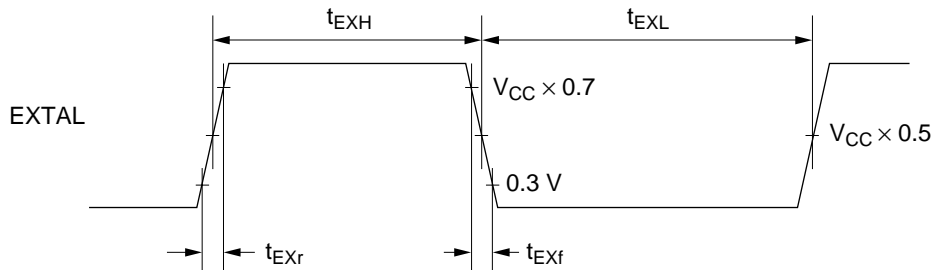
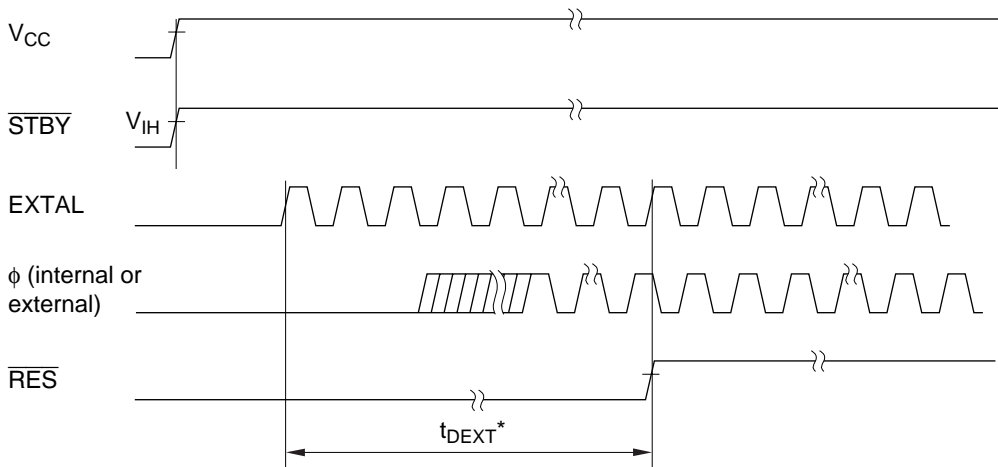

Figure 18.6 External Clock Input Timing



Note: * t_{DEXT} includes a 10 t_{cyc} \overline{RES} pulse width (t_{RESW}).

Figure 18.7 External Clock Output Settling Delay Timing

18.3 Duty Adjustment Circuit

When the oscillator frequency is 5 MHz or higher, the duty adjustment circuit adjusts the duty cycle of the clock signal from the oscillator to generate ϕ .

18.4 Prescalers

The prescalers divide the system clock (ϕ) to generate internal clocks ($\phi/2$ to $\phi/4096$).

18.5 Frequency Divider

The frequency divider divides the duty-adjusted clock signal to generate the system clock (ϕ). The frequency division ratio can be changed dynamically by modifying the value in DIVCR, as described below. Power consumption in the chip is reduced in almost direct proportion to the frequency division ratio. The system clock generated by the frequency divider can be output at the ϕ pin.

18.5.1 Register Configuration

Table 18.4 summarizes the frequency division register.

Table 18.4 Frequency Division Register

Address*	Name	Abbreviation	R/W	Initial Value
H'EE01B	Division control register	DIVCR	R/W	H'FC

Note: * Lower 20 bits of the address in advanced mode.

18.5.2 Division Control Register (DIVCR)

DIVCR is an 8-bit readable/writable register that selects the division ratio of the frequency divider.

Bit	7	6	5	4	3	2	1	0
	—	—	—	—	—	—	DIV1	DIV0
Initial value	1	1	1	1	1	1	0	0
Read/Write	—	—	—	—	—	—	R/W	R/W

Reserved bits

Divide bits 1 and 0

These bits select the frequency division ratio

DIVCR is initialized to H'FC by a reset and in hardware standby mode. It is not initialized in software standby mode.

Bits 7 to 2—Reserved: These bits cannot be modified and are always read as 1.

Bits 1 and 0—Divide (DIV1 and DIV0): These bits select the frequency division ratio, as follows.

Bit 1 DIV1	Bit 0 DIV0	Frequency Division Ratio	
0	0	1/1	(Initial value)
0	1	1/2	
1	0	1/4	
1	1	1/8	

18.5.3 Usage Notes

The DIVCR setting changes the ϕ frequency, so note the following points.

- Select a frequency division ratio that stays within the assured operation range specified for the clock cycle time t_{cyc} in the AC electrical characteristics. Set ϕ_{min} to the lower limit of the operating frequency range, and ensure that ϕ does not fall below this lower limit.
- All on-chip module operations are based on ϕ . Note that the timing of timer operations, serial communication, and other time-dependent processing differs before and after any change in the division ratio. The waiting time for exit from software standby mode also changes when the division ratio is changed. For details, see section 19.4.3, Selection of Waiting Time for Exit from Software Standby Mode.

Section 19 Power-Down State

19.1 Overview

The H8/3006 and H8/3007 have a power-down state that greatly reduces power consumption by halting the CPU, and a module standby function that reduces power consumption by selectively halting on-chip modules.

The power-down state includes the following three modes:

- Sleep mode
- Software standby mode
- Hardware standby mode

The module standby function can halt on-chip supporting modules independently of the power-down state. The modules that can be halted are the 16-bit timer, 8-bit timer, SCI0, SCI1, SCI2, DMAC, DRAM interface, and A/D converter.

Table 19.1 indicates the methods of entering and exiting the power-down modes and module standby mode, and gives the status of the CPU and on-chip supporting modules in each mode.

Table 19.1 Power-Down State and Module Standby Function

State

Mode/ Function	Entering Conditions	Clock	CPU Registers	DMAC	DRAM Interface	16-Bit Timer	8-Bit Timer	SC10	SC11	SC12	A/D	Other Modules	RAM	ϕ clock output ^{*4}	IO Ports	Exiting Conditions
Sleep mode	SLEEP instruction executed while SSBY = 0 in SYSCR	Active	Halted	Active	Active	Active	Active	Active	Active	Active	Active	Active	Held	ϕ output	Held	<ul style="list-style-type: none"> • Interrupt • RES • STBY
Software standby mode	SLEEP instruction executed while SSBY = 1 in SYSCR	Halted	Halted	reset	Halted	Halted	Halted	Halted	Halted	Halted	Halted	Halted	Held	High output	Held	<ul style="list-style-type: none"> • NMI • $\overline{IRQ_0}$ to $\overline{IRQ_2}$ • RES • STBY
Hardware standby mode	Low input at STBY pin	Halted	Undetermined	reset	Halted	Halted	Halted	Halted	Halted	Halted	Halted	Halted	Held	High impedance	High impedance	<ul style="list-style-type: none"> • STBY • RES
Module standby	Corresponding bit set to 1 in MSTCRH and MSTCRL	Active	Active	Halted ^{*2}	Halted ^{*2}	Halted ^{*2}	Halted ^{*2}	Halted ^{*2}	Halted ^{*2}	Halted ^{*2}	Halted ^{*2}	Halted ^{*2}	Held ^{*3}	High impedance ^{*2}	—	<ul style="list-style-type: none"> • STBY • RES • Clear MSTCR bit to 0^{*5}

Notes: 1. RTCNT and bits 7 and 6 of RTMCSR are initialized. Other bits and registers hold their previous states.

2. State in which the corresponding MSTCR bit was set to 1. For details see section 19.2.2, Module Standby Control RegisterH (MSTCRH) and section 19.2.3, Module Standby Control Register L (MSTCRL).

3. The RAME bit must be cleared to 0 in SYSCR before the transition from the program execution state to hardware standby mode.

4. When P6₇ is used as the ϕ output pin.

5. When a MSTCR bit is set to 1, the registers of the corresponding on-chip supporting module are initialized. To restart the module, first clear the MSTCR bit to 0, then set up the module registers again.

Legend

SYSCR: System control register

SSBY: Software standby bit

MSTCRH: Module standby control register H

MSTCRL: Module standby control register L

19.2 Register Configuration

The H8/3006 and H8/3007 have a system control register (SYSCR) that controls the power-down state, and module standby control registers H (MSTCRH) and L (MSTCRL) that control the module standby function. Table 19.2 summarizes these registers.

Table 19.2 Control Register

Address*	Name	Abbreviation	R/W	Initial Value
H'EE012	System control register	SYSCR	R/W	H'09
H'EE01C	Module standby control register H	MSTCRH	R/W	H'78
H'EE01D	Module standby control register L	MSTCRL	R/W	H'00

Note: * Lower 20 bits of the address in advanced mode.

19.2.1 System Control Register (SYSCR)

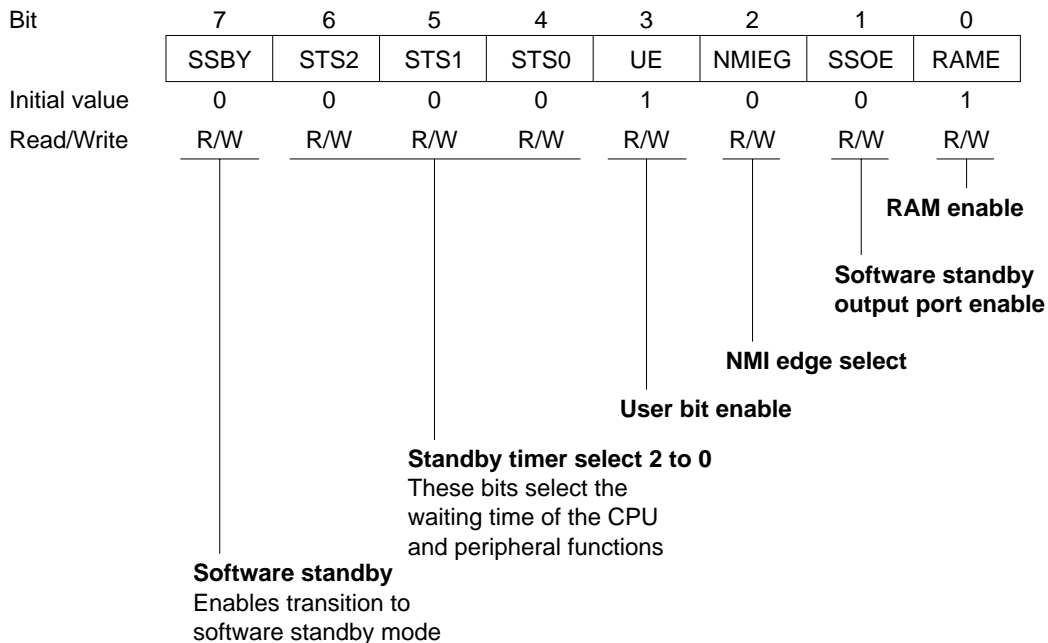

SYSCR is an 8-bit readable/writable register. Bit 7 (SSBY), bits 6 to 4 (STS2 to STS0), and bit 1 (SSOE) control the power-down state. For information on the other SYSCR bits, see section 3.3, System Control Register (SYSCR).

Bit 7—Software Standby (SSBY): Enables transition to software standby mode. When software standby mode is exited by an external interrupt, this bit remains set to 1 after the return to normal operation. To clear this bit, write 0.

Bit 7

SSBY	Description	
0	SLEEP instruction causes transition to sleep mode	(Initial value)
1	SLEEP instruction causes transition to software standby mode	

Bits 6 to 4—Standby Timer Select (STS2 to STS0): These bits select the length of time the CPU and on-chip supporting modules wait for the clock to settle when software standby mode is exited by an external interrupt. If the clock is generated by a crystal resonator, set these bits according to the clock frequency so that the waiting time will be at least 7 ms (oscillation settling time). See table 19.3. If an external clock is used, any setting is permitted.

Bit 6 STS2	Bit 5 STS1	Bit 4 STS0	Description	
0	0	0	Waiting time = 8,192 states	(Initial value)
		1	Waiting time = 16,384 states	
	1	0	Waiting time = 32,768 states	
		1	Waiting time = 65,536 states	
1	0	0	Waiting time = 131,072 states	
		1	Waiting time = 262,144 states	
	1	0	Waiting time = 1,024 states	
		1	Illegal setting	

Bit 1—Software Standby Output Port Enable (SSOE): Specifies whether the address bus and bus control signals (\overline{CS}_0 to \overline{CS}_7 , \overline{AS} , \overline{RD} , \overline{HWR} , \overline{LWR} , \overline{UCAS} , \overline{LCAS} , and \overline{RFSH}) are kept as outputs or fixed high, or placed in the high-impedance state in software standby mode.

Bit 1

SSOE	Description	
0	In software standby mode, the address bus and bus control signals are all high-impedance	(Initial value)
1	In software standby mode, the address bus retains its output state and bus control signals are fixed high	

19.2.2 Module Standby Control RegisterH (MSTCRH)

MSTCRH is an 8-bit readable/writable register that controls output of the system clock (ϕ). It also controls the module standby function, which places individual on-chip supporting modules in the standby state. Module standby can be designated for the SCI0, SCI1, SCI2.

Bit	7	6	5	4	3	2	1	0
	PSTOP	—	—	—	—	MSTPH2	MSTPH1	MSTPH0
Initial value	0	1	1	1	1	0	0	0
Read/Write	R/W	—	—	—	—	R/W	R/W	R/W

ϕ clock stop
Enables or disables output of the system clock

Reserved bit

Module standby H2 to 0
These bits select modules to be placed in standby

MSTCRH is initialized to H'78 by a reset and in hardware standby mode. It is not initialized in software standby mode.

Bit 7— ϕ Clock Stop (PSTOP): Enables or disables output of the system clock (ϕ).

Bit 1

PSTOP	Description	
0	System clock output is enabled	(Initial value)
1	System clock output is disabled	

Bits 6 to 3—Reserved: These bits cannot be modified and are always read as 1.

Bit 2—Module Standby H2 (MSTPH2): Selects whether to place the SCI2 in standby.

Bit 2

MSTPH2	Description	
0	SCI2 operates normally	(Initial value)
1	SCI2 is in standby state	

Bit 1—Module Standby H1 (MSTPH1): Selects whether to place the SCI1 in standby.

Bit 1

MSTPH1	Description	
0	SCI1 operates normally	(Initial value)
1	SCI1 is in standby state	

Bit 0—Module Standby H0 (MSTPH0): Selects whether to place the SCI0 in standby.

Bit 0

MSTPH0	Description	
0	SCI0 operates normally	(Initial value)
1	SCI0 is in standby state	

19.2.3 Module Standby Control Register L (MSTCRL)

MSTCRL is an 8-bit readable/writable register that controls the module standby function, which places individual on-chip supporting modules in the standby state. Module standby can be designated for the DMAC, 16-bit timer, DRAM interface, 8-bit timer, and A/D converter modules.

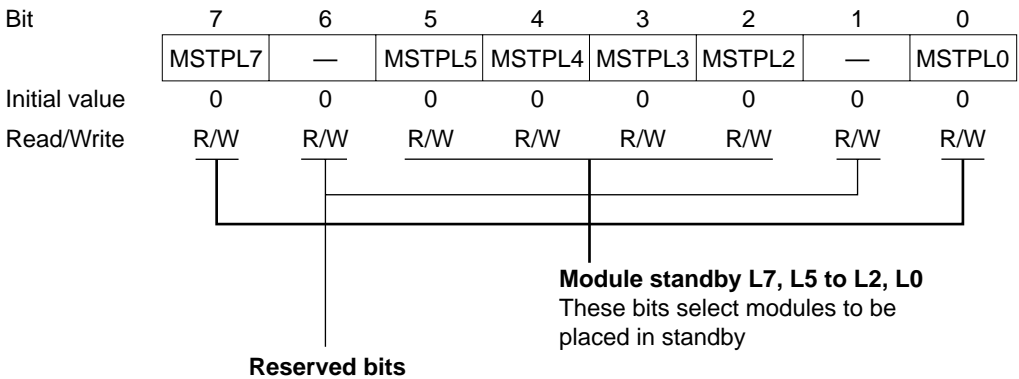

MSTCRL is initialized to H'00 by a reset and in hardware standby mode. It is not initialized in software standby mode.

Bit 7—Module Standby L7 (MSTPL7): Selects whether to place the DMAC in standby.

Bit 7

MSTPL7	Description	
0	DMAC operates normally	(Initial value)
1	DMAC is in standby state	

Bit 6—Reserved: This bit can be written and read.

Bit 5—Module Standby L5 (MSTPL5): Selects whether to place the DRAM interface in standby.

Bit 5

MSTPL5 Description

0	DRAM interface operates normally	(Initial value)
1	DRAM interface is in standby state	

Bit 4—Module Standby L4 (MSTPL4): Selects whether to place the 16-bit timer in standby.

Bit 4

MSTPL4 Description

0	16-bit timer operates normally	(Initial value)
1	16-bit timer is in standby state	

Bit 3—Module Standby L3 (MSTPL3): Selects whether to place 8-bit timer channels 0 and 1 in standby.

Bit 3

MSTPL3 Description

0	8-bit timer channels 0 and 1 operate normally	(Initial value)
1	8-bit timer channels 0 and 1 are in standby state	

Bit 2—Module Standby L2 (MSTPL2): Selects whether to place 8-bit timer channels 2 and 3 in standby.

Bit 2

MSTPL2 Description

0	8-bit timer channels 2 and 3 operate normally	(Initial value)
1	8-bit timer channels 2 and 3 are in standby state	

Bit 1—Reserved: This bit can be written and read.

Bit 0—Module Standby L0 (MSTPL0): Selects whether to place the A/D converter in standby.

Bit 0

MSTPL0 Description

0	A/D converter operates normally	(Initial value)
1	A/D converter is in standby state	

19.3 Sleep Mode

19.3.1 Transition to Sleep Mode

When the SSBY bit is cleared to 0 in SYSCR, execution of the SLEEP instruction causes a transition from the program execution state to sleep mode. Immediately after executing the SLEEP instruction the CPU halts, but the contents of its internal registers are retained. The DMA controller (DMAC), DRAM interface, and on-chip supporting modules do not halt in sleep mode. Modules which have been placed in standby by the module standby function, however, remain halted.

19.3.2 Exit from Sleep Mode

Sleep mode is exited by an interrupt, or by input at the $\overline{\text{RES}}$ or $\overline{\text{STBY}}$ pin.

Exit by Interrupt: An interrupt terminates sleep mode and causes a transition to the interrupt exception handling state. Sleep mode is not exited by an interrupt source in an on-chip supporting module if the interrupt is disabled in the on-chip supporting module. Sleep mode is not exited by an interrupt other than NMI if the interrupt is masked by interrupt priority settings and the settings of the I and UI bits in CCR, IPR.

Exit by $\overline{\text{RES}}$ Input: Low input at the $\overline{\text{RES}}$ pin exits from sleep mode to the reset state.

Exit by $\overline{\text{STBY}}$ Input: Low input at the $\overline{\text{STBY}}$ pin exits from sleep mode to hardware standby mode.

19.4 Software Standby Mode

19.4.1 Transition to Software Standby Mode

To enter software standby mode, execute the SLEEP instruction while the SSBY bit is set to 1 in SYSCR.

In software standby mode, current dissipation is reduced to an extremely low level because the CPU, clock, and on-chip supporting modules all halt. The DMAC and on-chip supporting modules are reset and halted. As long as the specified voltage is supplied, however, CPU register contents and on-chip RAM data are retained. The settings of the I/O ports and DRAM interface* are also held.

When the WDT is used as a watchdog timer ($WT/\overline{IT} = 1$), the TME bit must be cleared to 0 before setting SSBY. Also, when setting TME to 1, SSBY should be cleared to 0.

Clear the BRLE bit in BRCCR (inhibiting bus release) before making a transition to software standby mode.

Note: * RTCNT and bits 7 and 6 of RTMCSR are initialized. Other bits and registers hold their previous states.

19.4.2 Exit from Software Standby Mode

Software standby mode can be exited by input of an external interrupt at the NMI, $\overline{IRQ_0}$, $\overline{IRQ_1}$, or $\overline{IRQ_2}$ pin, or by input at the \overline{RES} or \overline{STBY} pin.

Exit by Interrupt: When an NMI, IRQ_0 , IRQ_1 , or IRQ_2 interrupt request signal is received, the clock oscillator begins operating. After the oscillator settling time selected by bits STS2 to STS0 in SYSCR, stable clock signals are supplied to the entire chip, software standby mode ends, and interrupt exception handling begins. Software standby mode is not exited if the interrupt enable bits of interrupts IRQ_0 , IRQ_1 , and IRQ_2 are cleared to 0, or if these interrupts are masked in the CPU.

Exit by \overline{RES} Input: When the \overline{RES} input goes low, the clock oscillator starts and clock pulses are supplied immediately to the entire chip. The \overline{RES} signal must be held low long enough for the clock oscillator to stabilize. When \overline{RES} goes high, the CPU starts reset exception handling.

Exit by \overline{STBY} Input: Low input at the \overline{STBY} pin causes a transition to hardware standby mode.

19.4.3 Selection of Waiting Time for Exit from Software Standby Mode

Bits STS2 to STS0 in SYSCR and bits DIV1 and DIV0 in DIVCR should be set as follows.

Crystal Resonator: Set STS2 to STS0, DIV1, and DIV0 so that the waiting time (for the clock to stabilize) is at least 7 ms. Table 19.3 indicates the waiting times that are selected by STS2 to STS0, DIV1, and DIV0 settings at various system clock frequencies.

External Clock: Any values may be set.

Table 19.3 Clock Frequency and Waiting Time for Clock to Settle

DIV1	DIV0	STS2	STS1	STS0	Waiting Time	20 MHz	18 MHz	16 MHz	12 MHz	10 MHz	8 MHz	6 MHz	4 MHz	2 MHz	1 MHz	Unit
0	0	0	0	0	8192 states	0.4	0.46	0.51	0.65	0.8	1.0	1.3	2.0	4.1	8.2*	ms
		0	0	1	16384 states	0.8	0.91	1.0	1.3	1.6	2.0	2.7	4.1	8.2*	16.4	
		0	1	0	32768 states	1.6	1.8	2.0	2.7	3.3	4.1	5.5	8.2*	16.4	32.8	
		0	1	1	65536 states	3.3	3.6	4.1	5.5	6.6	8.2*	10.9*	16.4	32.8	65.5	
		1	0	0	131072 states	6.6	7.3*	8.2*	10.9*	13.1*	16.4	21.8	32.8	65.5	131.1	
		1	0	1	262144 states	13.1*	14.6	16.4	21.8	26.2	32.8	43.7	65.5	131.1	262.1	
		1	1	0	1024 states	0.05	0.057	0.064	0.085	0.10	0.13	0.17	0.26	0.51	1.0	
		1	1	1	Illegal setting											
0	1	0	0	0	8192 states	0.8	0.91	1.02	1.4	1.6	2.0	2.7	4.1	8.2*	16.4*	ms
		0	0	1	16384 states	1.6	1.8	2.0	2.7	3.3	4.1	5.5	8.2*	16.4	32.8	
		0	1	0	32768 states	3.3	3.6	4.1	5.5	6.6	8.2*	10.9*	16.4	32.8	65.5	
		0	1	1	65536 states	6.6	7.3*	8.2*	10.9*	13.1*	16.4	21.8	32.8	65.5	131.1	
		1	0	0	131072 states	13.1*	14.6	16.4	21.8	26.2	32.8	43.7	65.5	131.1	262.1	
		1	0	1	262144 states	26.2	29.1	32.8	43.7	52.4	65.5	87.4	131.1	262.1	524.3	
		1	1	0	1024 states	0.10	0.11	0.13	0.17	0.20	0.26	0.34	0.51	1.0	2.0	
		1	1	1	Illegal setting											
1	0	0	0	0	8192 states	1.6	1.8	2.0	2.7	3.3	4.1	5.5	8.2*	16.4*	32.8*	ms
		0	0	1	16384 states	3.3	3.6	4.1	5.5	6.6	8.2*	10.9*	16.4	32.8	65.5	
		0	1	0	32768 states	6.6	7.3*	8.2*	10.9*	13.1*	16.4	21.8	32.8	65.5	131.1	
		0	1	1	65536 states	13.1*	14.6	16.4	21.8	26.2	32.8	43.7	65.5	131.1	262.1	
		1	0	0	131072 states	26.2	29.1	32.8	43.7	52.4	65.5	87.4	131.1	262.1	524.3	
		1	0	1	262144 states	52.4	58.3	65.5	87.4	104.9	131.1	174.8	262.1	524.3	1048.6	
		1	1	0	1024 states	0.20	0.23	0.26	0.34	0.41	0.51	0.68	1.02	2.0	4.1	
		1	1	1	Illegal setting											
1	1	0	0	0	8192 states	3.3	3.6	4.1	5.5	6.6	8.2*	10.9*	16.4*	32.8*	65.5	ms
		0	0	1	16384 states	6.6	7.3*	8.2*	10.9*	13.1*	16.4	21.8	32.8	65.5	131.1	
		0	1	0	32768 states	13.1*	14.6	16.4	21.8	26.2	32.8	43.7	65.5	131.1	262.1	
		0	1	1	65536 states	26.2	29.1	32.8	43.7	52.4	65.5	87.4	131.1	262.1	524.3	
		1	0	0	131072 states	52.4	58.3	65.5	87.4	104.9	131.1	174.8	262.1	524.3	1048.6	
		1	0	1	262144 states	104.9	116.5	131.1	174.8	209.7	262.1	349.5	524.3	1048.6	2097.1	
		1	1	0	1024 states	0.41	0.46	0.51	0.68	0.82	1.0	1.4	2.0	4.1	8.2*	
		1	1	1	Illegal setting											

*: Recommended setting

19.4.4 Sample Application of Software Standby Mode

Figure 19.1 shows an example in which software standby mode is entered at the fall of NMI and exited at the rise of NMI.

With the NMI edge select bit (NMIEG) cleared to 0 in SYSCR (selecting the falling edge), an NMI interrupt occurs. Next the NMIEG bit is set to 1 (selecting the rising edge) and the SSBY bit is set to 1; then the SLEEP instruction is executed to enter software standby mode.

Software standby mode is exited at the next rising edge of the NMI signal.

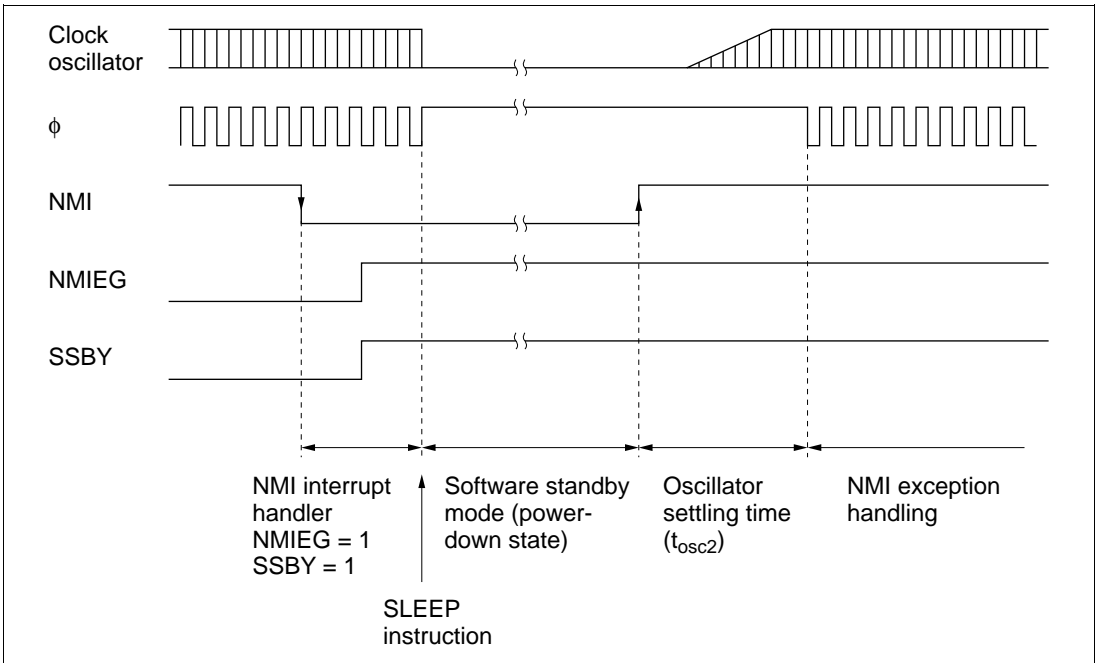

Figure 19.1 NMI Timing for Software Standby Mode (Example)

19.4.5 Note

The I/O ports retain their existing states in software standby mode. If a port is in the high output state, its output current is not reduced.

19.5 Hardware Standby Mode

19.5.1 Transition to Hardware Standby Mode

Regardless of its current state, the chip enters hardware standby mode whenever the $\overline{\text{STBY}}$ pin goes low. Hardware standby mode reduces power consumption drastically by halting all functions of the CPU, DMAC, DRAM interface, and on-chip supporting modules. All modules are reset except the on-chip RAM. As long as the specified voltage is supplied, on-chip RAM data is retained. I/O ports are placed in the high-impedance state.

Clear the RAME bit to 0 in SYSCR before $\overline{\text{STBY}}$ goes low to retain on-chip RAM data.

The inputs at the mode pins (MD2 to MD0) should not be changed during hardware standby mode.

19.5.2 Exit from Hardware Standby Mode

Hardware standby mode is exited by inputs at the $\overline{\text{STBY}}$ and $\overline{\text{RES}}$ pins. While $\overline{\text{RES}}$ is low, when $\overline{\text{STBY}}$ goes high, the clock oscillator starts running. $\overline{\text{RES}}$ should be held low long enough for the clock oscillator to settle. When $\overline{\text{RES}}$ goes high, reset exception handling begins, followed by a transition to the program execution state.

19.5.3 Timing for Hardware Standby Mode

Figure 19.2 shows the timing relationships for hardware standby mode. To enter hardware standby mode, first drive $\overline{\text{RES}}$ low, then drive $\overline{\text{STBY}}$ low. To exit hardware standby mode, first drive $\overline{\text{STBY}}$ high, wait for the clock to settle, then bring $\overline{\text{RES}}$ from low to high.

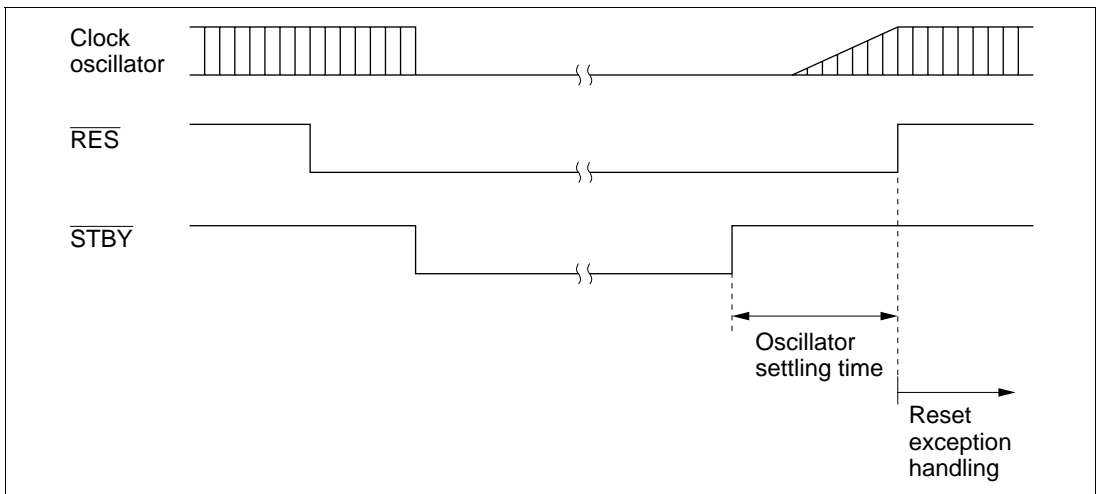

Figure 19.2 Hardware Standby Mode Timing

19.6 Module Standby Function

19.6.1 Module Standby Timing

The module standby function can halt several of the on-chip supporting modules (SCI2, SCI1, SCIO, the DMAC, 16-bit timer, 8-bit timer, DRAM interface, and A/D converter) independently in the power-down state. This standby function is controlled by bits MSTPH2 to MSTPH0 in MSTCRH and bits MSTPL7 to MSTPL0 in MSTCRL. When one of these bits is set to 1, the corresponding on-chip supporting module is placed in standby and halts at the beginning of the next bus cycle after the MSTCR write cycle.

19.6.2 Read/Write in Module Standby

When an on-chip supporting module is in module standby, read/write access to its registers is disabled. Read access always results in H'FF data. Write access is ignored.

19.6.3 Usage Notes

When using the module standby function, note the following points.

DMAC: When setting a bit in MSTCR to 1 to place the DMAC or DRAM interface in module standby, make sure that the DMAC or DRAM interface is not currently requesting the bus right. If the corresponding bit in MSTCR is set to 1 when a bus request is present, operation of the bus arbiter becomes ambiguous and a malfunction may occur.

DRAM Interface: When the module standby function is used on the DRAM interface, set the MSTCR bit to 1 while DRAM space is deselected.

Cancellation of Interrupt Handling: Before setting a module standby bit, first disable interrupts by that module. When an on-chip supporting module is placed in standby by the module standby function, its registers are initialized, including registers with interrupt request flags.

Pin States: Pins used by an on-chip supporting module lose their module functions when the module is placed in module standby. What happens after that depends on the particular pin. For details, see section 8, I/O Ports. Pins that change from the input to the output state require special care. For example, if SCI1 is placed in module standby, the receive data pin loses its receive data function and becomes a port pin. If its port DDR bit is set to 1, the pin becomes a data output pin, and its output may collide with external SCI transmit data. Data collision should be prevented by clearing the port DDR bit to 0 or taking other appropriate action.

Register Resetting: When an on-chip supporting module is halted by the module standby function, all its registers are initialized. To restart the module, after its MSTCR bit is cleared to 0, its registers must be set up again. It is not possible to write to the registers while the MSTCR bit is set to 1.

MSTCR Access from DMAC Disabled: To prevent malfunctions, MSTCR can only be accessed from the CPU. It can be read by the DMAC, but it cannot be written by the DMAC.

19.7 System Clock Output Disabling Function

Output of the system clock (ϕ) can be controlled by the PSTOP bit in MSTCRH. When the PSTOP bit is set to 1, output of the system clock halts and the ϕ pin is placed in the high-impedance state. Figure 19.3 shows the timing of the stopping and starting of system clock output. When the PSTOP bit is cleared to 0, output of the system clock is enabled. Table 19.4 indicates the state of the ϕ pin in various operating states.

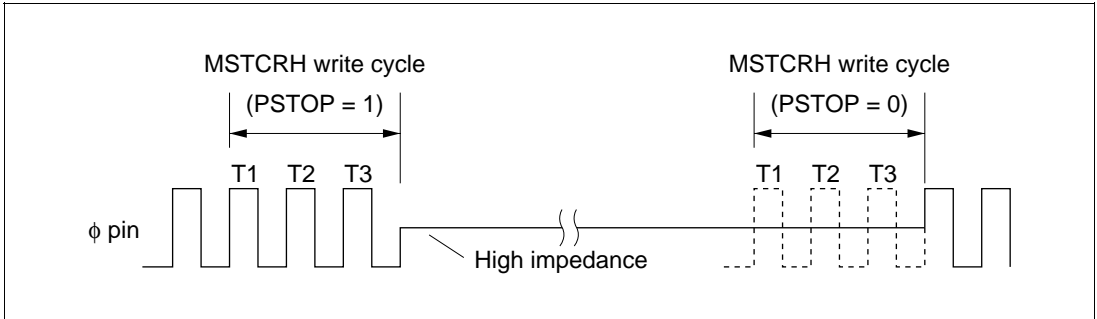

Figure 19.3 Starting and Stopping of System Clock Output

Table 19.4 ϕ Pin State in Various Operating States

Operating State	PSTOP = 0	PSTOP = 1
Hardware standby	High impedance	High impedance
Software standby	Always high	High impedance
Sleep mode	System clock output	High impedance
Normal operation	System clock output	High impedance

Section 20 Electrical Characteristics

20.1 Absolute Maximum Ratings

Table 20.1 lists the absolute maximum ratings.

Table 20.1 Absolute Maximum Ratings

Item	Symbol	Value	Unit
Power supply voltage	V_{CC}	-0.3 to +7.0	V
Input voltage (except for port 7)	V_{in}	-0.3 to $V_{CC} + 0.3$	V
Input voltage (port 7)	V_{in}	-0.3 to $AV_{CC} + 0.3$	V
Reference voltage	V_{REF}	-0.3 to $AV_{CC} + 0.3$	V
Analog power supply voltage	AV_{CC}	-0.3 to +7.0	V
Analog input voltage	V_{AN}	-0.3 to $AV_{CC} + 0.3$	V
Operating temperature	T_{opr}	Regular specifications: -20 to +75	°C
		Wide-range specifications: -40 to +85	°C
Storage temperature	T_{stg}	-55 to +125	°C

Caution: Permanent damage to the chip may result if absolute maximum ratings are exceeded.

20.2 Electrical Characteristics

20.2.1 DC Characteristics

Tables 20.2, 20.3 and 20.4 list the DC characteristics. Table 20.4 lists the permissible output currents.

Table 20.2 DC Characteristics (1)

Conditions: $V_{CC} = 5.0 \text{ V} \pm 10\%$, $AV_{CC} = 5.0 \text{ V} \pm 10\%$, $V_{REF} = 4.5 \text{ V}$ to AV_{CC}^{*1} ,
 $V_{SS} = AV_{SS} = 0 \text{ V}^{*1}$, $T_a = -20^\circ\text{C}$ to $+75^\circ\text{C}$ (regular specifications),
 $T_a = -40^\circ\text{C}$ to $+85^\circ\text{C}$ (wide-range specifications)

Item		Symbol	Min	Typ	Max	Unit	Test Conditions
Schmitt trigger input voltages	Port A,	V_T^-	1.0	—	—	V	
	P8 ₀ to P8 ₂	V_T^+	—	—	$V_{CC} \times 0.7$	V	
		$V_T^+ - V_T^-$	0.4	—	—	V	
Input high voltage	$\overline{\text{RES}}$, $\overline{\text{STBY}}$, NMI, MD ₂ to MD ₀	V_{IH}	$V_{CC} - 0.7$	—	$V_{CC} + 0.3$	V	
	EXTAL		$V_{CC} \times 0.7$	—	$V_{CC} + 0.3$	V	
	Port 7		2.0	—	$AV_{CC} + 0.3$	V	
	Ports 4, 6, P8 ₃ , P8 ₄ , P9 ₀ to P9 ₅ , port B, D ₁₅ to D ₈		2.0	—	$V_{CC} + 0.3$	V	
Input low voltage	$\overline{\text{RES}}$, $\overline{\text{STBY}}$, MD ₂ to MD ₀	V_{IL}	-0.3	—	0.5	V	
	NMI, EXTAL, ports 4, 6, 7, P8 ₃ , P8 ₄ , P9 ₀ to P9 ₅ , port B, D ₁₅ to D ₈		-0.3	—	0.8	V	
Output high voltage	All output pins (except $\overline{\text{RESO}}$)	V_{OH}	$V_{CC} - 0.5$	—	—	V	$I_{OH} = -200 \mu\text{A}$
			3.5	—	—	V	$I_{OH} = -1 \text{ mA}$
Output low voltage	All output pins (except $\overline{\text{RESO}}$)	V_{OL}	—	—	0.4	V	$I_{OL} = 1.6 \text{ mA}$
		A ₁₉ to A ₀	—	—	1.0	V	$I_{OL} = 10 \text{ mA}$
		$\overline{\text{RESO}}$	—	—	0.4	V	$I_{OL} = 2.6 \text{ mA}$

Item	Symbol	Min	Typ	Max	Unit	Test Conditions	
Input leakage current	$\overline{\text{STBY}}$, NMI, RES, MD ₂ to MD ₀	$ I_{in} $	—	—	1.0	μA $V_{in} = 0.5 \text{ V}$ to $V_{CC} - 0.5 \text{ V}$	
	Port 7	—	—	1.0	μA $V_{in} = 0.5 \text{ V}$ to $AV_{CC} - 0.5 \text{ V}$		
Three-state leakage current	Ports 4, 6, 8 to B, A ₁₉ to A ₀ , D ₁₅ to D ₈	$ I_{TSL} $	—	—	1.0	μA $V_{in} = 0.5 \text{ V}$ to $V_{CC} - 0.5 \text{ V}$	
	$\overline{\text{RES0}}$	—	—	10.0	μA $V_{in} = 0 \text{ V}$		
Input pull-up MOS current	Port 4	$-I_p$	50	—	300	μA $V_{in} = 0 \text{ V}$	
Input capacitance	NMI	C_{in}	—	—	50	pF $V_{in} = 0 \text{ V}$	
	All input pins except NMI	—	—	—	15	pF $f = 1 \text{ MHz}$ $T_a = 25^\circ\text{C}$	
Current dissipation*2	Normal operation	I_{CC}^{*3}	—	45 (5.0 V)	100	mA $f = 20 \text{ MHz}$	
	Sleep mode	—	—	35 (5.0 V)	73	mA $f = 20 \text{ MHz}$	
	Module standby mode	—	—	18 (5.0 V)	51	mA $f = 20 \text{ MHz}$	
	Standby mode	—	—	—	0.01	5.0	μA $T_a \leq 50^\circ\text{C}$
		—	—	—	—	20.0	μA $50^\circ\text{C} \leq T_a$
Analog power supply current	During A/D conversion	AI_{CC}	—	0.6	1.5	mA	
	During A/D and D/A conversion	—	—	0.6	1.5	mA	
	Idle	—	—	0.01	5.0	μA DASTE = 0	
Reference current	During A/D conversion	AI_{CC}	—	0.5	0.8	mA	
	During A/D and D/A conversion	—	—	2.0	3.0	mA	
	Idle	—	—	0.01	5.0	μA DASTE = 0	
RAM standby voltage	V_{RAM}	2.0	—	—	V		

Notes: 1. Do not open the pin connections of the AV_{CC} , V_{REF} and AV_{SS} pins while the A/D converter is not in use.

Connect the AV_{CC} and V_{REF} pins to the V_{CC} and connect the AV_{SS} pin to the V_{SS} , respectively.

2. Given current consumption values are when all the output pins are made to unloaded state and, furthermore, when the on-chip pull-up MOS is turned off under conditions that $V_{IH\ min} = V_{CC} - 0.5\ V$ and $V_{IL\ max} = 0.5\ V$.

Also, the aforesaid current consumption values are when $V_{IH\ min} = V_{CC} \times 0.9$ and $V_{IL\ max} = 0.3\ V$ under the condition of $V_{RAM} \leq V_{CC} < 4.5\ V$.

3. $I_{CC\ max.}$ (under normal operations) = $1.0\ (mA) + 0.90\ (mA/(MHz \times V)) \times V_{CC} \times f$
 $I_{CC\ max.}$ (when using the sleeve) = $1.0\ (mA) + 0.65\ (mA/(MHz \times V)) \times V_{CC} \times f$
 $I_{CC\ max.}$ (when the sleeve + module are standing by)
= $1.0\ (mA) + 0.45\ (mA/(MHz \times V)) \times V_{CC} \times f$

Also, the typ. values for current dissipation are reference values.

Table 20.3 DC Characteristics (2)

Conditions: $V_{CC} = 2.7$ to 5.5 V, $AV_{CC} = 2.7$ to 5.5 V, $V_{REF} = 2.7$ V to AV_{CC}^{*1} ,
 $V_{SS} = AV_{SS} = 0$ V^{*1}, $T_a = -20^{\circ}\text{C}$ to $+75^{\circ}\text{C}$ (regular specifications),
 $T_a = -40^{\circ}\text{C}$ to $+85^{\circ}\text{C}$ (wide-range specifications)

Item		Symbol	Min	Typ	Max	Unit	Test Conditions
Schmitt trigger input voltages	Port A,	V_T^-	$V_{CC} \times 0.2$	—	—	V	
	P8 ₀ to P8 ₂	V_T^+	—	—	$V_{CC} \times 0.7$	V	
		$V_T^+ - V_T^-$	$V_{CC} \times 0.07$	—	—	V	
Input high voltage	$\overline{\text{RES}}$, $\overline{\text{STBY}}$, NMI, MD ₂ to MD ₀	V_{IH}	$V_{CC} \times 0.9$	—	$V_{CC} + 0.3$	V	
	EXTAL		$V_{CC} \times 0.7$	—	$V_{CC} + 0.3$	V	
	Port 7		$V_{CC} \times 0.7$	—	$AV_{CC} + 0.3$	V	
	Ports 4, 6, P8 ₃ , P8 ₄ , P9 ₀ to P9 ₅ , port B, D ₁₅ to D ₈		$V_{CC} \times 0.7$	—	$V_{CC} + 0.3$	V	
Input low voltage	$\overline{\text{RES}}$, $\overline{\text{STBY}}$, MD ₂ to MD ₀	V_{IL}	-0.3	—	$V_{CC} \times 0.1$	V	
	NMI, EXTAL, Ports 4, 6, 7, P8 ₃ , P8 ₄ , P9 ₀ to P9 ₅ , port B, D ₁₅ to D ₈		-0.3	—	$V_{CC} \times 0.2$ 0.8	V V	$V_{CC} < 4.0$ V $V_{CC} = 4.0$ to 5.5 V
Output high voltage	All output pins (except $\overline{\text{RESO}}$)	V_{OH}	$V_{CC} - 0.5$	—	—	V	$I_{OH} = -200$ μA
			$V_{CC} - 1.0$	—	—	V	$I_{OH} = -1$ mA
Output low voltage	All output pins (except $\overline{\text{RESO}}$)	V_{OL}	—	—	0.4	V	$I_{OL} = 1.6$ mA
	A ₁₉ to A ₀		—	—	1.0	V	$I_{OL} = 5$ mA ($V_{CC} < 4.0$ V) $I_{OL} = 10$ mA ($V_{CC} = 4.0$ to 5.5 V)
	$\overline{\text{RESO}}$		—	—	0.4	V	$I_{OL} = 1.6$ mA

Item	Symbol	Min	Typ	Max	Unit	Test Conditions	
Input leakage current	$\overline{\text{STBY}}$, NMI, RES, MD ₂ to MD ₀	$ I_{in} $	—	—	1.0	μA $V_{in} = 0.5 \text{ V}$ to $V_{CC} - 0.5 \text{ V}$	
	Port 7	—	—	1.0	μA $V_{in} = 0.5 \text{ V}$ to $AV_{CC} - 0.5 \text{ V}$		
Three-state leakage current	Ports 4, 6, 8 to B, A ₁₉ to A ₀ , D ₁₅ to D ₈	$ I_{TSI} $	—	—	1.0	μA $V_{in} = 0.5 \text{ V}$ to $V_{CC} - 0.5 \text{ V}$	
	$\overline{\text{RESO}}$	—	—	10.0	μA $V_{in} = 0 \text{ V}$		
Input pull-up MOS current	Port 4	$-I_p$	10	—	300	μA $V_{in} = 0 \text{ V}$	
Input capacitance	NMI	C_{in}	—	—	50	pF $V_{in} = 0 \text{ V}$	
	All input pins except NMI	—	—	15	pF $f = 1 \text{ MHz}$ $T_a = 25^\circ\text{C}$		
Current dissipation*2	Normal operation	I_{CC}^{*3}	—	15 (3.0 V)	51	mA $f = 10 \text{ MHz}$	
	Sleep mode	—	—	9 (3.0 V)	37	mA $f = 10 \text{ MHz}$	
	Module standby mode	—	—	6 (3.0 V)	26	mA $f = 10 \text{ MHz}$	
	Standby mode	—	—	—	0.01	5.0	μA $T_a \leq 50^\circ\text{C}$
		—	—	—	—	20.0	μA $50^\circ\text{C} \leq T_a$
Analog power supply current	During A/D conversion	AI_{CC}	—	0.2	0.5	mA $AV_{CC} = 3.0 \text{ V}$	
			—	0.6	—	mA $AV_{CC} = 5.0 \text{ V}$	
	During A/D and D/A conversion	—	—	0.2	0.5	mA $AV_{CC} = 3.0 \text{ V}$	
			—	0.6	—	mA $AV_{CC} = 5.0 \text{ V}$	
	Idle	—	—	0.01	5.0	μA DASTE = 0	
Reference current	During A/D conversion	AI_{CC}	—	0.3	0.5	mA $V_{REF} = 3.0 \text{ V}$	
			—	0.5	—	mA $V_{REF} = 5.0 \text{ V}$	
	During A/D and D/A conversion	—	—	1.2	2.0	mA $V_{REF} = 3.0 \text{ V}$	
			—	2.0	—	mA $V_{REF} = 5.0 \text{ V}$	
	Idle	—	—	0.01	5.0	μA DASTE = 0	
RAM standby voltage	V_{RAM}	2.0	—	—	V		

Notes: 1. Do not open the pin connections of the AV_{CC} , V_{REF} and AV_{SS} pins while the A/D converter is not in use.

Connect the AV_{CC} and V_{REF} pins to the V_{CC} and connect the AV_{SS} pin to the V_{SS}, respectively.

- Given current consumption values are when all the output pins are made to unloaded state and, furthermore, when the on-chip pull-up MOS is turned off under conditions that V_{IH} min = V_{CC} - 0.5 V and V_{IL} max = 0.5 V.

Also, the aforesaid current consumption values are when V_{IH} min = V_{CC} × 0.9 and V_{IL} max = 0.3 V under the condition of V_{RAM} ≤ V_{CC} < 2.7 V.

- I_{CC} max. (under normal operations) = 1.0 (mA) + 0.90 (mA/(MHz × V)) × V_{CC} × f
 I_{CC} max. (when using the sleeve) = 1.0 (mA) + 0.65 (mA/(MHz × V)) × V_{CC} × f
 I_{CC} max. (when the sleeve + module are standing by)
= 1.0 (mA) + 0.45 (mA/(MHz × V)) × V_{CC} × f

Also, the typ. values for current dissipation are reference values.

Table 20.4 DC Characteristics (3)

Conditions: $V_{CC} = 3.0$ to 5.5 V, $AV_{CC} = 3.0$ to 5.5 V, $V_{REF} = 3.0$ V to AV_{CC}^{*1} ,
 $V_{SS} = AV_{SS} = 0$ V^{*1}, $T_a = -20^\circ\text{C}$ to $+75^\circ\text{C}$ (regular specifications),
 $T_a = -40^\circ\text{C}$ to $+85^\circ\text{C}$ (wide-range specifications)

Item	Symbol	Min	Typ	Max	Unit	Test Conditions	
Schmitt trigger input voltages	Port A,	V_T^-	$V_{CC} \times 0.2$	—	—	V	
	P8 ₀ to P8 ₂	V_T^+	—	—	$V_{CC} \times 0.7$	V	
		$V_T^+ - V_T^-$	$V_{CC} \times 0.07$	—	—	V	
Input high voltage	\overline{RES} , \overline{STBY} , NMI, MD ₂ to MD ₀	V_{IH}	$V_{CC} \times 0.9$	—	$V_{CC} + 0.3$	V	
	EXTAL		$V_{CC} \times 0.7$	—	$V_{CC} + 0.3$	V	
	Port 7		$V_{CC} \times 0.7$	—	$AV_{CC} + 0.3$	V	
	Ports 4, 6, P8 ₃ , P8 ₄ , P9 ₀ to P9 ₅ , Port B, D ₁₅ to D ₈		$V_{CC} \times 0.7$	—	$V_{CC} + 0.3$	V	
Input low voltage	\overline{RES} , \overline{STBY} , MD ₂ to MD ₀	V_{IL}	-0.3	—	$V_{CC} \times 0.1$	V	
	NMI, EXTAL, Ports 4, 6, 7, P8 ₃ , P8 ₄ , P9 ₀ to P9 ₅ , Port B, D ₁₅ to D ₈		-0.3	—	$V_{CC} \times 0.2$ 0.8	V V $V_{CC} < 4.0$ V $V_{CC} = 4.0$ to 5.5 V	
Output high voltage	All output pins (except \overline{RESO})	V_{OH}	$V_{CC} - 0.5$	—	—	V	$I_{OH} = -200 \mu\text{A}$
			$V_{CC} - 1.0$	—	—	V	$I_{OH} = -1 \text{ mA}$
Output low voltage	All output pins (except \overline{RESO})	V_{OL}	—	—	0.4	V	$I_{OL} = 1.6 \text{ mA}$
			—	—	1.0	V	$I_{OL} = 5 \text{ mA}$ ($V_{CC} < 4.0$ V) $I_{OL} = 10 \text{ mA}$ ($V_{CC} = 4.0$ to 5.5 V)
	\overline{RESO}		—	—	0.4	V	$I_{OL} = 1.6 \text{ mA}$

Item	Symbol	Min	Typ	Max	Unit	Test Conditions
Input leakage current	\overline{STBY} , NMI, RES, MD ₂ to MD ₀	$ I_{in} $	—	—	1.0	μA $V_{in} = 0.5\text{ V}$ to $V_{CC} - 0.5\text{ V}$
	Port 7	—	—	1.0	μA $V_{in} = 0.5\text{ V}$ to $AV_{CC} - 0.5\text{ V}$	
Three-state leakage current	Ports 4, 6, 8 to B, A ₁₉ to A ₀ , D ₁₅ to D ₈	$ I_{TSI} $	—	—	1.0	μA $V_{in} = 0.5\text{ V}$ to $V_{CC} - 0.5\text{ V}$
	\overline{RESO}	—	—	10.0	μA $V_{in} = 0\text{ V}$	
Input pull-up MOS current	Port 4	$-I_p$	10	—	300	μA $V_{in} = 0\text{ V}$
Input capacitance	NMI	C_{in}	—	—	50	pF $V_{in} = 0\text{ V}$ $f = 1\text{ MHz}$ $T_a = 25^\circ\text{C}$
	All input pins except NMI	—	—	—	15	pF
Current dissipation*2	Normal operation	I_{CC}^{*3}	—	20 (3.5 V)	66	mA $f = 13\text{ MHz}$
	Sleep mode	—	—	15 (3.5 V)	48	mA $f = 13\text{ MHz}$
	Module standby mode	—	—	9 (3.5 V)	34	mA $f = 13\text{ MHz}$
	Standby mode	—	—	0.01	5.0	μA $T_a \leq 50^\circ\text{C}$
		—	—	—	20.0	μA $50^\circ\text{C} \leq T_a$
Analog power supply current	During A/D conversion	AI_{CC}	—	0.2	0.5	mA $AV_{CC} = 3.0\text{ V}$
			—	0.6	—	mA $AV_{CC} = 5.0\text{ V}$
	During A/D and D/A conversion	—	—	0.2	0.5	mA $AV_{CC} = 3.0\text{ V}$
			—	0.6	—	mA $AV_{CC} = 5.0\text{ V}$
	Idle	—	—	0.01	5.0	μA DASTE = 0
Reference current	During A/D conversion	AI_{CC}	—	0.3	0.5	mA $V_{REF} = 3.0\text{ V}$
			—	0.5	—	mA $V_{REF} = 5.0\text{ V}$
	During A/D and D/A conversion	—	—	1.2	2.0	mA $V_{REF} = 3.0\text{ V}$
			—	2.0	—	mA $V_{REF} = 5.0\text{ V}$
	Idle	—	—	0.01	5.0	μA DASTE = 0
RAM standby voltage	V_{RAM}	2.0	—	—	V	

Notes: 1. Do not open the pin connections of the AV_{CC} , V_{REF} and AV_{SS} pins while the A/D converter is not in use.

Connect the AV_{CC} and V_{REF} pins to the V_{CC} and connect the AV_{SS} pin to the V_{SS} , respectively.

2. Given current consumption values are when all the output pins are made to unloaded state and, furthermore, when the on-chip pull-up MOS is turned off under conditions that $V_{IH\ min} = V_{CC} - 0.5\ V$ and $V_{IL\ max} = 0.5\ V$.

Also, the aforesaid current consumption values are when $V_{IH\ min} = V_{CC} \times 0.9$ and $V_{IL\ max} = 0.3\ V$ under the condition of $V_{RAM} \leq V_{CC} < 3.0\ V$.

3. $I_{CC\ max.}$ (under normal operations) = $1.0\ (mA) + 0.90\ (mA/(MHz \times V)) \times V_{CC} \times f$
 $I_{CC\ max.}$ (when using the sleeve) = $1.0\ (mA) + 0.65\ (mA/(MHz \times V)) \times V_{CC} \times f$
 $I_{CC\ max.}$ (when the sleeve + module are standing by)
= $1.0\ (mA) + 0.45\ (mA/(MHz \times V)) \times V_{CC} \times f$

Also, the typ. values for current dissipation are reference values.

Table 20.5 Permissible Output Currents

Conditions: $V_{CC} = 2.7 \text{ V to } 5.5 \text{ V}$, $AV_{CC} = 2.7 \text{ V to } 5.5 \text{ V}$, $V_{REF} = 2.7 \text{ V to } AV_{CC}$,
 $V_{SS} = AV_{SS} = 0 \text{ V}$, $T_a = -20^\circ\text{C to } +75^\circ\text{C}$ (regular specifications),
 $T_a = -40^\circ\text{C to } +85^\circ\text{C}$ (wide-range specifications)

Item	Symbol	Min	Typ	Max	Unit
Permissible output low current (per pin)	A_{19} to A_0	—	—	10	mA
	Other output pins	—	—	2.0	mA
Permissible output low current (total)	Total of 20 pins in A_{19} to A_0	—	—	80	mA
	Total of all output pins, including the above	—	—	120	mA
Permissible output high current (per pin)	All output pins	—	—	2.0	mA
Permissible output high current (total)	Total of all output pins	—	—	40	mA

- Notes: 1. To protect chip reliability, do not exceed the output current values in table 20.5.
2. When driving a darlington pair, always insert a current-limiting resistor in the output line, as shown in figures 20.1.

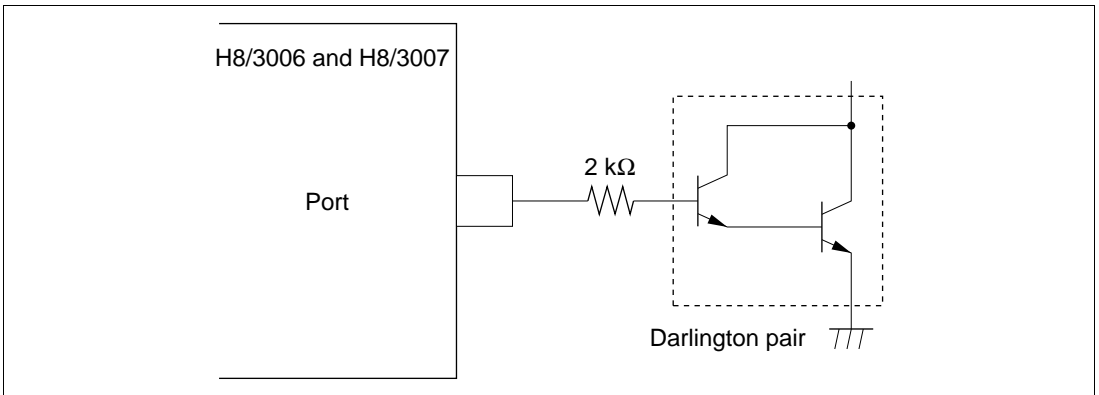

Figure 20.1 Darlington Pair Drive Circuit (Example)

20.2.2 AC Characteristics

Clock timing parameters are listed in table 20.6, control signal timing parameters in table 20.7, and bus timing parameters in table 20.8. Timing parameters of the on-chip supporting modules are listed in table 20.9.

Table 20.6 Clock Timing

Condition: $T_a = -20^\circ\text{C}$ to $+75^\circ\text{C}$ (regular specifications), $T_a = -40^\circ\text{C}$ to $+85^\circ\text{C}$ (wide-range specifications)

Condition A: $V_{CC} = 2.7$ to 5.5 V, $AV_{CC} = 2.7$ to 5.5 V, $V_{REF} = 2.7$ to AV_{CC} , $V_{SS} = AV_{SS} = 0$ V, $\phi = 1$ to 10 MHz

Condition B: $V_{CC} = 3.0$ to 5.5 V, $AV_{CC} = 3.0$ to 5.5 V, $V_{REF} = 3.0$ to AV_{CC} , $V_{SS} = AV_{SS} = 0$ V, $\phi = 1$ to 13 MHz

Condition C: $V_{CC} = 5.0$ V \pm 10%, $AV_{CC} = 5.0$ V \pm 10%, $V_{REF} = 4.5$ to AV_{CC} , $V_{SS} = AV_{SS} = 0$ V, $\phi = 1$ to 20 MHz

Item	Symbol	Condition						Unit	Test Conditions
		A		B		C			
		Min	Max	Min	Max	Min	Max		
Clock cycle time	t_{cyc}	100	1000	76.9	1000	50	1000	ns	Figure 20.3
Clock pulse low width	t_{CL}	30	—	20	—	15	—	ns	
Clock pulse high width	t_{CH}	30	—	20	—	15	—	ns	
Clock rise time	t_{Cr}	—	20	—	15	—	10	ns	
Clock fall time	t_{Cf}	—	20	—	15	—	10	ns	
Clock oscillator settling time at reset	t_{OSC1}	20	—	20	—	20	—	ms	Figure 20.4
Clock oscillator settling time in software standby	t_{OSC2}	7	—	7	—	7	—	ms	Figure 19.1

Table 20.7 Control Signal Timing

Condition: $T_a = -20^{\circ}\text{C}$ to $+75^{\circ}\text{C}$ (regular specifications), $T_a = -40^{\circ}\text{C}$ to $+85^{\circ}\text{C}$ (wide-range specifications)

Condition A: $V_{CC} = 2.7$ to 5.5 V, $AV_{CC} = 2.7$ to 5.5 V, $V_{REF} = 2.7$ to AV_{CC} , $V_{SS} = AV_{SS} = 0$ V, $\phi = 1$ to 10 MHz

Condition B: $V_{CC} = 3.0$ to 5.5 V, $AV_{CC} = 3.0$ to 5.5 V, $V_{REF} = 3.0$ to AV_{CC} , $V_{SS} = AV_{SS} = 0$ V, $\phi = 1$ to 13 MHz

Condition C: $V_{CC} = 5.0$ V \pm 10%, $AV_{CC} = 5.0$ V \pm 10%, $V_{REF} = 4.5$ to AV_{CC} , $V_{SS} = AV_{SS} = 0$ V, $\phi = 1$ to 20 MHz

Item	Symbol	Condition						Unit	Test Conditions
		A		B		C			
		Min	Max	Min	Max	Min	Max		
$\overline{\text{RES}}$ setup time	t_{RESS}	200	—	200	—	150	—	ns	Figure 20.5
$\overline{\text{RES}}$ pulse width	t_{RESW}	10	—	10	—	10	—	t_{cyc}	
Mode programming setup time	t_{MDS}	200	—	200	—	200	—	ns	
$\overline{\text{RESO}}$ output delay time	t_{RESD}	—	100	—	100	—	50	ns	Figure 20.6
$\overline{\text{RESO}}$ output pulse width	t_{RESOW}	132	—	132	—	132	—	t_{cyc}	
NMI, $\overline{\text{IRQ}}$ setup time	t_{NMIS}	200	—	200	—	150	—	ns	Figure 20.7
NMI, $\overline{\text{IRQ}}$ hold time	t_{NMIH}	10	—	10	—	10	—	ns	
NMI, $\overline{\text{IRQ}}$ pulse width	t_{NMIW}	200	—	200	—	200	—	ns	

Table 20.8 Bus Timing

Condition: $T_a = -20^{\circ}\text{C}$ to $+75^{\circ}\text{C}$ (regular specifications), $T_a = -40^{\circ}\text{C}$ to $+85^{\circ}\text{C}$ (wide-range specifications)

Condition A: $V_{CC} = 2.7$ to 5.5 V, $AV_{CC} = 2.7$ to 5.5 V, $V_{REF} = 2.7$ to AV_{CC} , $V_{SS} = AV_{SS} = 0$ V, $\phi = 1$ to 10 MHz

Condition B: $V_{CC} = 3.0$ to 5.5 V, $AV_{CC} = 3.0$ to 5.5 V, $V_{REF} = 3.0$ to AV_{CC} , $V_{SS} = AV_{SS} = 0$ V, $\phi = 1$ to 13 MHz

Condition C: $V_{CC} = 5.0$ V \pm 10%, $AV_{CC} = 5.0$ V \pm 10%, $V_{REF} = 4.5$ to AV_{CC} , $V_{SS} = AV_{SS} = 0$ V, $\phi = 1$ to 20 MHz

Item	Symbol	Condition						Unit	Test Conditions
		A		B		C			
		Min	Max	Min	Max	Min	Max		
Address delay time	t_{AD}	—	50	—	40	—	25	ns	Figure 20.8, figure 20.9, figure 20.11, figure 20.12
Address hold time	t_{AH}	$0.5 t_{cyc}$ – 45	—	$0.5 t_{cyc}$ – 35	—	$0.5 t_{cyc}$ – 20	—	ns	
Read strobe delay time	t_{RSD}	—	60	—	50	—	25	ns	
Address strobe delay time	t_{ASD}	—	60	—	50	—	25	ns	
Write strobe delay time	t_{WSD}	—	60	—	50	—	25	ns	
Strobe delay time	t_{SD}	—	60	—	50	—	25	ns	
Write strobe pulse width 1	t_{WSW1}	$1.0 t_{cyc}$ – 50	—	$1.0 t_{cyc}$ – 40	—	$1.0 t_{cyc}$ – 25	—	ns	
Write strobe pulse width 2	t_{WSW2}	$1.5 t_{cyc}$ – 50	—	$1.5 t_{cyc}$ – 40	—	$1.5 t_{cyc}$ – 25	—	ns	
Address setup time 1	t_{AS1}	$0.5 t_{cyc}$ – 45	—	$0.5 t_{cyc}$ – 35	—	$0.5 t_{cyc}$ – 20	—	ns	
Address setup time 2	t_{AS2}	$1.0 t_{cyc}$ – 45	—	$1.0 t_{cyc}$ – 35	—	$1.0 t_{cyc}$ – 20	—	ns	
Read data setup time	t_{RDS}	50	—	40	—	25	—	ns	
Read data hold time	t_{RDH}	0	—	0	—	0	—	ns	
Write data delay time	t_{WDD}	—	60	—	50	—	35	ns	

Item	Symbol	Condition						Unit	Test Conditions
		A		B		C			
		Min	Max	Min	Max	Min	Max		
Write data setup time 1	t_{WDS1}	$1.0 t_{cyc}$ - 50	—	$1.0 t_{cyc}$ - 40	—	$1.0 t_{cyc}$ - 30	—	ns	Figure 20.8, figure 20.9, figure 20.11, figure 20.12
Write data setup time 2	t_{WDS2}	$2.0 t_{cyc}$ - 50	—	$2.0 t_{cyc}$ - 40	—	$2.0 t_{cyc}$ - 30	—	ns	
Write data hold time	t_{WDH}	$0.5 t_{cyc}$ - 30	—	$0.5 t_{cyc}$ - 25	—	$0.5 t_{cyc}$ - 15	—	ns	
Read data access time 1	t_{ACC1}	—	$2.0 t_{cyc}$ - 100	—	$2.0 t_{cyc}$ - 80	—	$2.0 t_{cyc}$ - 45	ns	
Read data access time 2	t_{ACC2}	—	$3.0 t_{cyc}$ - 100	—	$3.0 t_{cyc}$ - 80	—	$3.0 t_{cyc}$ - 45	ns	
Read data access time 3	t_{ACC3}	—	$1.5 t_{cyc}$ - 100	—	$1.5 t_{cyc}$ - 80	—	$1.5 t_{cyc}$ - 45	ns	
Read data access time 4	t_{ACC4}	—	$2.5 t_{cyc}$ - 100	—	$2.5 t_{cyc}$ - 80	—	$2.5 t_{cyc}$ - 45	ns	
Precharge time 1	t_{PCH1}	$1.0 t_{cyc}$ - 40	—	$1.0 t_{cyc}$ - 30	—	$1.0 t_{cyc}$ - 20	—	ns	
Precharge time 2	t_{PCH2}	$0.5 t_{cyc}$ - 40	—	$0.5 t_{cyc}$ - 30	—	$0.5 t_{cyc}$ - 20	—	ns	
Wait setup time	t_{WTS}	40	—	40	—	25	—	ns	Figure 20.10
Wait hold time	t_{WTH}	5	—	5	—	5	—	ns	
Bus request setup time	t_{BRQS}	40	—	40	—	25	—	ns	Figure 20.13
Bus acknowledge delay time 1	t_{BACD1}	—	60	—	50	—	30	ns	
Bus acknowledge delay time 2	t_{BACD2}	—	60	—	50	—	30	ns	
Bus-floating time	t_{BZD}	—	60	—	50	—	30	ns	
$\overline{\text{RAS}}$ precharge time	t_{RP}	$1.5 t_{cyc}$ - 50	—	$1.5 t_{cyc}$ - 40	—	$1.5 t_{cyc}$ - 25	—	ns	Figure 20.14 to figure 20.16
$\overline{\text{CAS}}$ precharge time	t_{CP}	$0.5 t_{cyc}$ - 30	—	$0.5 t_{cyc}$ - 25	—	$0.5 t_{cyc}$ - 15	—	ns	
Low address hold time	t_{RAH}	$0.5 t_{cyc}$ - 30	—	$0.5 t_{cyc}$ - 25	—	$0.5 t_{cyc}$ - 15	—	ns	
$\overline{\text{RAS}}$ delay time 1	t_{RAD1}	—	60	—	50	—	25	ns	
$\overline{\text{RAS}}$ delay time 2	t_{RAD2}	—	60	—	50	—	30	ns	

Item	Symbol	Condition						Unit	Test Conditions
		A		B		C			
		Min	Max	Min	Max	Min	Max		
$\overline{\text{CAS}}$ delay time 1	t_{CASD1}	—	60	—	50	—	25	ns	Figure 20.14 to figure 20.16
$\overline{\text{CAS}}$ delay time 2	t_{CASD2}	—	60	—	50	—	25	ns	
$\overline{\text{WE}}$ delay time	t_{WCD}	—	60	—	50	—	25	ns	
$\overline{\text{CAS}}$ pulse width 1	t_{CAS1}	1.5 t_{cyc} – 50	—	1.5 t_{cyc} – 40	—	1.5 t_{cyc} – 20	—	ns	
$\overline{\text{CAS}}$ pulse width 2	t_{CAS2}	1.0 t_{cyc} – 50	—	1.0 t_{cyc} – 40	—	1.0 t_{cyc} – 20	—	ns	
$\overline{\text{CAS}}$ pulse width 3	t_{CAS3}	1.0 t_{cyc} – 50	—	1.0 t_{cyc} – 40	—	1.0 t_{cyc} – 20	—	ns	
$\overline{\text{RAS}}$ access time	t_{RAC}	—	2.5 t_{cyc} – 80	—	2.5 t_{cyc} – 70	—	2.5 t_{cyc} – 40	ns	
Address access time	t_{AA}	—	2.0 t_{cyc} – 100	—	2.0 t_{cyc} – 80	—	2.0 t_{cyc} – 50	ns	
$\overline{\text{CAS}}$ access time	t_{CAC}	—	1.5 t_{cyc} – 100	—	1.5 t_{cyc} – 80	—	1.5 t_{cyc} – 50	ns	
$\overline{\text{WE}}$ setup time	t_{WCS}	0.5 t_{cyc} – 45	—	0.5 t_{cyc} – 35	—	0.5 t_{cyc} – 20	—	ns	
$\overline{\text{WE}}$ hold time	t_{WCH}	0.5 t_{cyc} – 40	—	0.5 t_{cyc} – 28	—	0.5 t_{cyc} – 15	—	ns	
Write data setup time	t_{WDS}	0.5 t_{cyc} – 45	—	0.5 t_{cyc} – 35	—	0.5 t_{cyc} – 20	—	ns	
$\overline{\text{WE}}$ write data hold time	t_{WDH}	0.5 t_{cyc} – 30	—	0.5 t_{cyc} – 25	—	0.5 t_{cyc} – 15	—	ns	
$\overline{\text{CAS}}$ setup time 1	t_{CSR1}	0.5 t_{cyc} – 30	—	0.5 t_{cyc} – 25	—	0.5 t_{cyc} – 20	—	ns	
$\overline{\text{CAS}}$ setup time 2	t_{CSR2}	0.5 t_{cyc} – 30	—	0.5 t_{cyc} – 25	—	0.5 t_{cyc} – 15	—	ns	
$\overline{\text{CAS}}$ hold time	t_{CHR}	0.5 t_{cyc} – 30	—	0.5 t_{cyc} – 25	—	0.5 t_{cyc} – 15	—	ns	
$\overline{\text{RAS}}$ pulse width	t_{RAS}	1.5 t_{cyc} – 30	—	1.5 t_{cyc} – 25	—	1.5 t_{cyc} – 15	—	ns	

Table 20.9 Timing of On-Chip Supporting Modules

Condition: $T_a = -20^{\circ}\text{C}$ to $+75^{\circ}\text{C}$ (regular specifications), $T_a = -40^{\circ}\text{C}$ to $+85^{\circ}\text{C}$ (wide-range specifications)

Condition A: $V_{CC} = 2.7$ to 5.5 V, $AV_{CC} = 2.7$ to 5.5 V, $V_{REF} = 2.7$ to AV_{CC} , $V_{SS} = AV_{SS} = 0$ V, $\phi = 1$ to 10 MHz

Condition B: $V_{CC} = 3.0$ to 5.5 V, $AV_{CC} = 3.0$ to 5.5 V, $V_{REF} = 3.0$ to AV_{CC} , $V_{SS} = AV_{SS} = 0$ V, $\phi = 1$ to 13 MHz

Condition C: $V_{CC} = 5.0$ V $\pm 10\%$, $AV_{CC} = 5.0$ V $\pm 10\%$, $V_{REF} = 4.5$ to AV_{CC} , $V_{SS} = AV_{SS} = 0$ V, $\phi = 1$ to 20 MHz

Item	Symbol	Condition						Unit	Test Conditions		
		A		B		C					
		Min	Max	Min	Max	Min	Max				
Ports and TPC	Output data delay time	t_{PWD}	—	100	—	100	—	50	ns	Figure 20.17	
	Input data setup time	t_{PRS}	50	—	50	—	50	—	ns		
	Input data hold time	t_{PRH}	50	—	50	—	50	—	ns		
16-bit timer	Timer output delay time	t_{TOCD}	—	100	—	100	—	50	ns	Figure 20.18	
	Timer input setup time	t_{TICS}	50	—	50	—	50	—	ns		
	Timer clock input setup time	t_{TCKS}	50	—	50	—	50	—	ns	Figure 20.19	
	Timer clock pulse width	Single edge	t_{TCKWH}	1.5	—	1.5	—	1.5	—	t_{cyc}	
Both edges		t_{TCKWL}	2.5	—	2.5	—	2.5	—	t_{cyc}		
8-bit timer	Timer output delay time	t_{TOCD}	—	100	—	100	—	50	ns	Figure 20.18	
	Timer input setup time	t_{TICS}	50	—	50	—	50	—	ns		
	Timer clock input setup time	t_{TCKS}	50	—	50	—	50	—	ns	Figure 20.19	
	Timer clock pulse width	Single edge	t_{TCKWH}	1.5	—	1.5	—	1.5	—	t_{cyc}	
		Both edges	t_{TCKWL}	2.5	—	2.5	—	2.5	—	t_{cyc}	

Item		Symbol	Condition						Unit	Test Conditions	
			A		B		C				
			Min	Max	Min	Max	Min	Max			
SCI	Input clock cycle	Asynchronous	t_{Scyc}	4	—	4	—	4	—	t_{cyc}	Figure 20.20
		Synchronous		6	—	6	—	6	—	t_{cyc}	
	Input clock rise time	t_{SCKr}	1.5	—	1.5	—	1.5	—	t_{cyc}		
	Input clock fall time	t_{SCKf}	1.5	—	1.5	—	1.5	—	t_{cyc}		
	Input clock pulse width	t_{SCKW}	0.4	0.6	0.4	0.6	0.4	0.6	t_{Scyc}		
	Transmit data delay time	t_{TXD}	—	100	—	100	—	100	ns	Figure 20.21	
	Receive data setup time (synchronous)	t_{RXS}	100	—	100	—	100	—	ns		
Receive data hold time (synchronous)	Clock input	t_{RXH}	100	—	100	—	100	—	ns		
			Clock output	0	—	0	—	0	—	ns	
DMAC	\overline{TEND} delay time 1	t_{TED1}	—	100	—	100	—	50	ns	Figure 20.22, figure 20.23	
	\overline{TEND} delay time 2	t_{TED2}	—	100	—	100	—	50	ns		
	\overline{DREQ} setup time	t_{DRQS}	40	—	40	—	25	—	ns	Figure 20.24	
	\overline{DREQ} hold time	t_{DRQH}	10	—	10	—	10	—	ns		

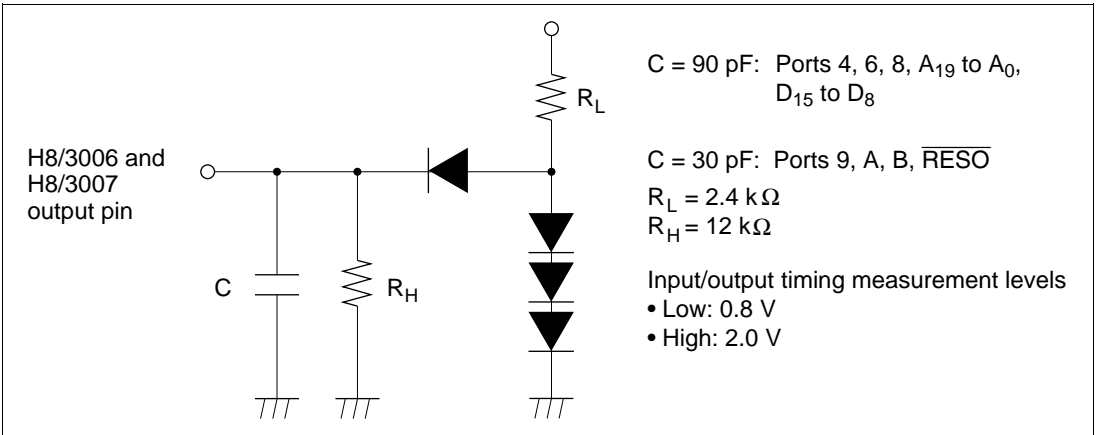

Figure 20.2 Output Load Circuit

20.2.3 A/D Conversion Characteristics

Table 20.10 lists the A/D conversion characteristics.

Table 20.10 A/D Conversion Characteristics

Condition: $T_a = -20^\circ\text{C}$ to $+75^\circ\text{C}$ (regular specifications), $T_a = -40^\circ\text{C}$ to $+85^\circ\text{C}$ (wide-range specifications)

Condition A: $V_{CC} = 2.7$ to 5.5 V, $AV_{CC} = 2.7$ to 5.5 V, $V_{REF} = 2.7$ to AV_{CC} , $V_{SS} = AV_{SS} = 0$ V, $f_{max} = 10$ MHz

Condition B: $V_{CC} = 3.0$ to 5.5 V, $AV_{CC} = 3.0$ to 5.5 V, $V_{REF} = 3.0$ to AV_{CC} , $V_{SS} = AV_{SS} = 0$ V, $f_{max} = 13$ MHz

Condition C: $V_{CC} = 5.0$ V \pm 10%, $AV_{CC} = 5.0$ V \pm 10%, $V_{REF} = 4.5$ to AV_{CC} , $V_{SS} = AV_{SS} = 0$ V, $f_{max} = 20$ MHz

Item		Condition									Unit	
		A			B			C				
		Min	Typ	Max	Min	Typ	Max	Min	Typ	Max		
Conversion time: 134 states	Resolution	10	10	10	10	10	10	10	10	10	bits	
	Conversion time (single mode)	—	—	134	—	—	134	—	—	134	t_{cyc}	
	Analog input capacitance	—	—	20	—	—	20	—	—	20	pF	
	Permissible signal-source impedance	$\phi \leq 13$ MHz	—	—	—	—	—	—	—	—	10	k Ω
		$\phi > 13$ MHz	—	—	—	—	—	—	—	—	5	k Ω
		4.0 V $\leq AV_{CC} \leq 5.5$ V	—	—	10	—	—	10	—	—	—	k Ω
		2.7 V $\leq AV_{CC} < 4.0$ V	—	—	5	—	—	5	—	—	—	k Ω
	Nonlinearity error	—	—	± 7.5	—	—	± 7.5	—	—	± 3.5	LSB	
Offset error	—	—	± 7.5	—	—	± 7.5	—	—	± 3.5	LSB		
Full-scale error	—	—	± 7.5	—	—	± 7.5	—	—	± 3.5	LSB		
Quantization error	—	—	± 0.5	—	—	± 0.5	—	—	± 0.5	LSB		
Absolute accuracy	—	—	± 8.0	—	—	± 8.0	—	—	± 4.0	LSB		

Item		Condition									Unit	
		A			B			C				
		Min	Typ	Max	Min	Typ	Max	Min	Typ	Max		
Conversion time: 70 states	Resolution	10	10	10	10	10	10	10	10	10	bits	
	Conversion time (single mode)	—	—	70	—	—	70	—	—	70	t_{cyc}	
	Analog input capacitance	—	—	20	—	—	20	—	—	20	pF	
	Permissible signal-source impedance	$\phi \leq 13$ MHz	—	—	—	—	—	—	—	—	5	k Ω
		$\phi > 13$ MHz	—	—	—	—	—	—	—	—	3	k Ω
		$4.0\text{ V} \leq AV_{CC} \leq 5.5\text{ V}$	—	—	5	—	—	5	—	—	—	k Ω
		$2.7\text{ V} \leq AV_{CC} < 4.0\text{ V}$	—	—	3	—	—	3	—	—	—	k Ω
	Nonlinearity error	—	—	± 15.5	—	—	± 15.5	—	—	± 7.5	LSB	
	Offset error	—	—	± 15.5	—	—	± 15.5	—	—	± 7.5	LSB	
	Full-scale error	—	—	± 15.5	—	—	± 15.5	—	—	± 7.5	LSB	
Quantization error	—	—	± 0.5	—	—	± 0.5	—	—	± 0.5	LSB		
Absolute accuracy	—	—	± 16	—	—	± 16	—	—	± 8.0	LSB		

20.2.4 D/A Conversion Characteristics

Table 20.11 lists the D/A conversion characteristics.

Table 20.11 D/A Conversion Characteristics

Condition: $T_a = -20^\circ\text{C}$ to $+75^\circ\text{C}$ (regular specifications), $T_a = -40^\circ\text{C}$ to $+85^\circ\text{C}$ (wide-range specifications)

Condition A: $V_{CC} = 2.7$ to 5.5 V, $AV_{CC} = 2.7$ to 5.5 V, $V_{REF} = 2.7$ to AV_{CC} , $V_{SS} = AV_{SS} = 0$ V, $f_{max} = 10$ MHz

Condition B: $V_{CC} = 3.0$ to 5.5 V, $AV_{CC} = 3.0$ to 5.5 V, $V_{REF} = 3.0$ to AV_{CC} , $V_{SS} = AV_{SS} = 0$ V, $f_{max} = 13$ MHz

Condition C: $V_{CC} = 5.0$ V \pm 10%, $AV_{CC} = 5.0$ V \pm 10%, $V_{REF} = 4.5$ to AV_{CC} , $V_{SS} = AV_{SS} = 0$ V, $f_{max} = 20$ MHz

Item	Condition									Unit	Test Conditions
	A			B			C				
	Min	Typ	Max	Min	Typ	Max	Min	Typ	Max		
Resolution	8	8	8	8	8	8	8	8	8	Bits	
Conversion time (centering time)	—	—	10	—	—	10	—	—	10	μs	20 pF capacitive load
Absolute accuracy	—	± 2.0	± 3.0	—	± 2.0	± 3.0	—	± 1.5	± 2.0	LSB	2 M Ω resistive load
	—	—	± 2.0	—	—	± 2.0	—	—	± 1.5	LSB	4 M Ω resistive load

20.3 Operational Timing

This section shows timing diagrams.

20.3.1 Clock Timing

Clock timing is shown as follows:

- System clock timing
Figure 20.3 shows the system clock timing.
- Oscillator settling timing
Figure 20.4 shows the oscillator settling timing.

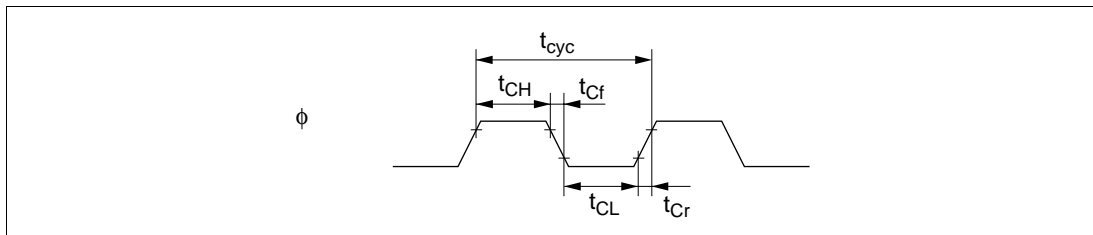

Figure 20.3 System Clock Timing

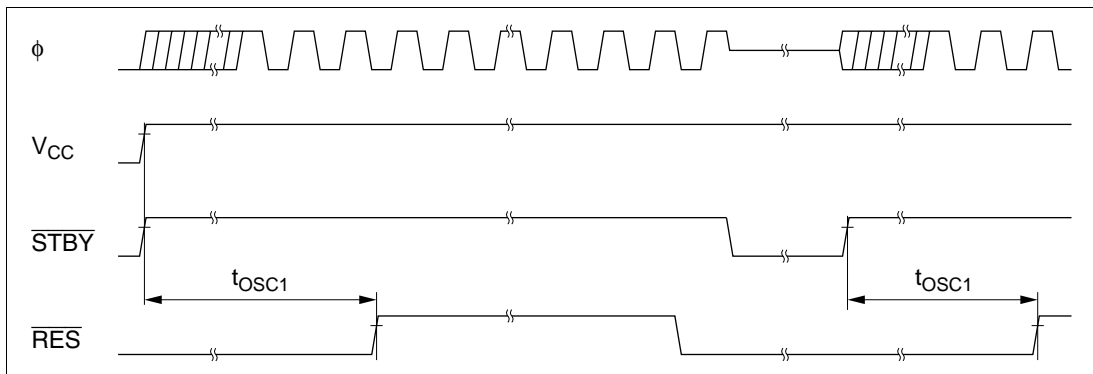

Figure 20.4 Oscillator Settling Timing

20.3.2 Control Signal Timing

Control signal timing is shown as follows:

- Reset input timing
Figure 20.5 shows the reset input timing.
- Reset output timing
Figure 20.6 shows the reset output timing.
- Interrupt input timing
Figure 20.7 shows the interrupt input timing for NMI and \overline{IRQ}_5 to \overline{IRQ}_0 .

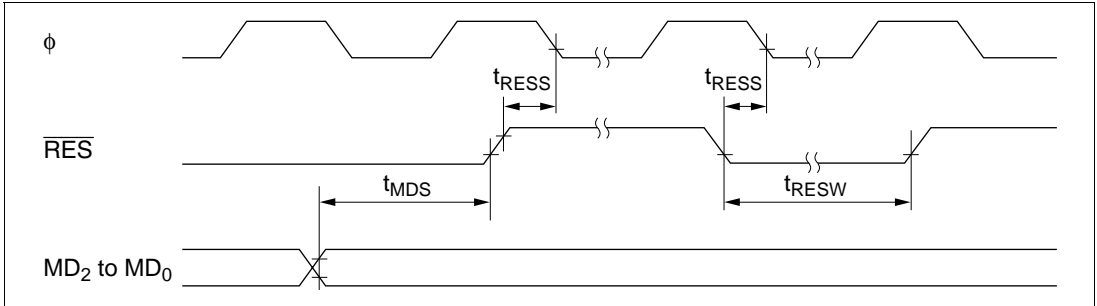

Figure 20.5 Reset Input Timing

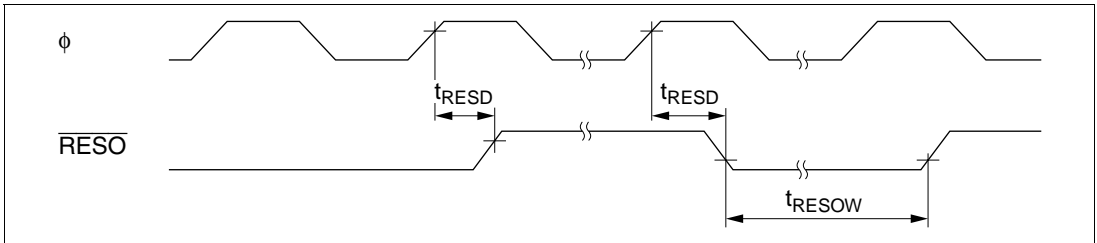

Figure 20.6 Reset Output Timing

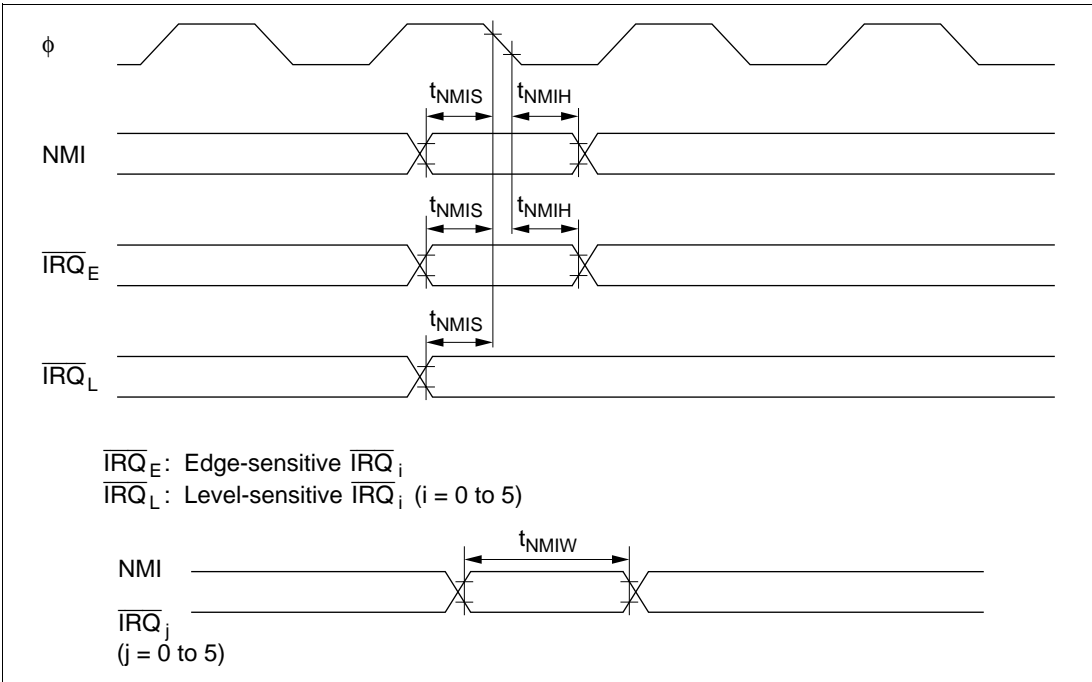
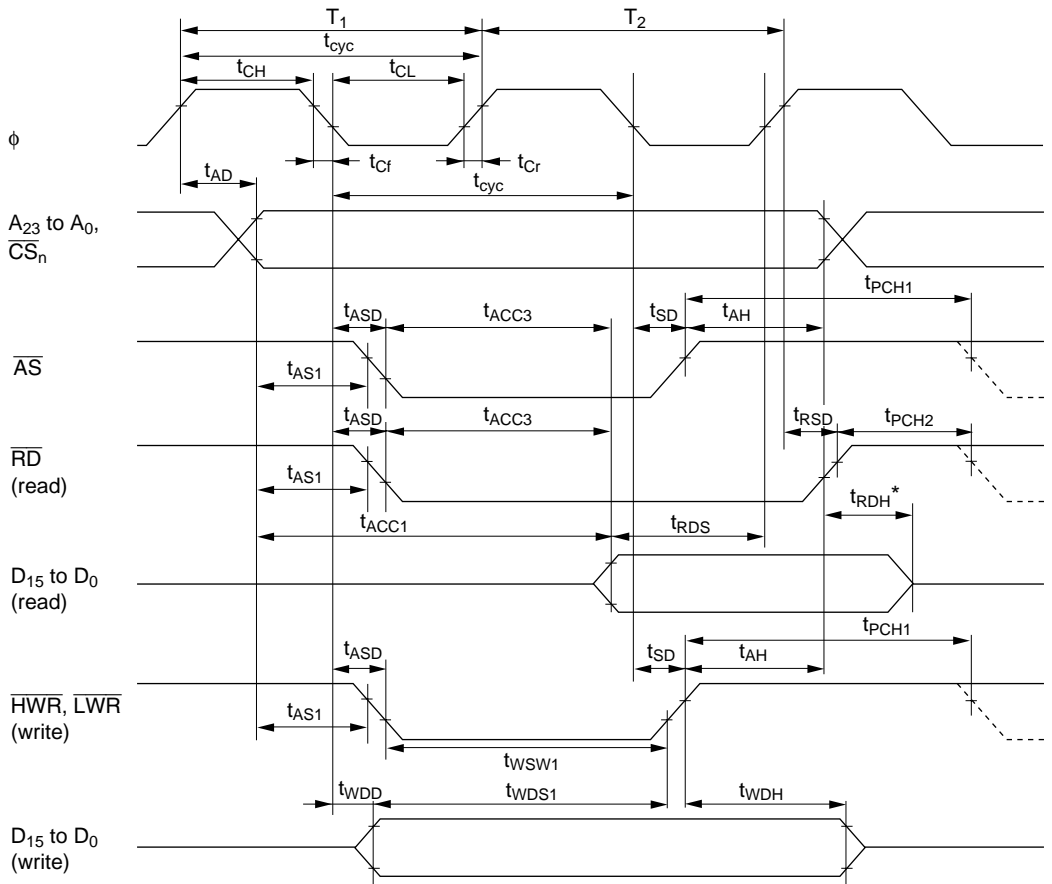

Figure 20.7 Interrupt Input Timing

20.3.3 Bus Timing

Bus timing is shown as follows:

- Basic bus cycle: two-state access
Figure 20.8 shows the timing of the external two-state access cycle.
- Basic bus cycle: three-state access
Figure 20.9 shows the timing of the external three-state access cycle.
- Basic bus cycle: three-state access with one wait state
Figure 20.10 shows the timing of the external three-state access cycle with one wait state inserted.
- Burst ROM access timing: burst cycle two-state
Figure 20.11 shows the timing of the burst cycle two-state access.
- Burst ROM access timing: burst cycle three-state
Figure 20.12 shows the timing of the burst cycle three-state access.
- Bus-release mode timing
Figure 20.13 shows the bus-release mode timing.



Note: * Specification from the earliest negation timing of A₂₃ to A₀, CS_n, and RD.

Figure 20.8 Basic Bus Cycle: Two-State Access

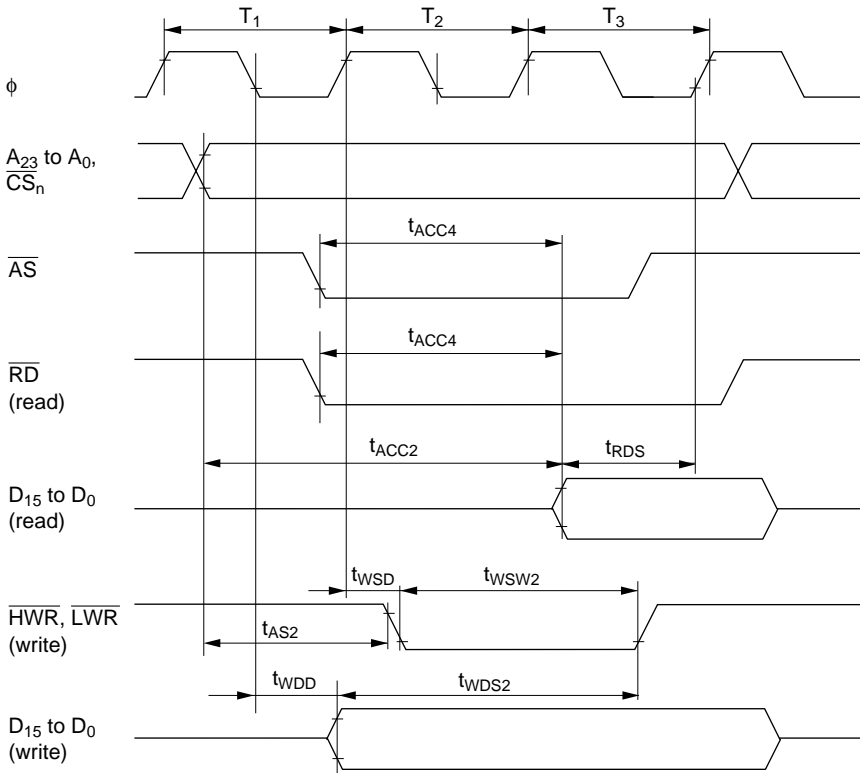

Figure 20.9 Basic Bus Cycle: Three-State Access

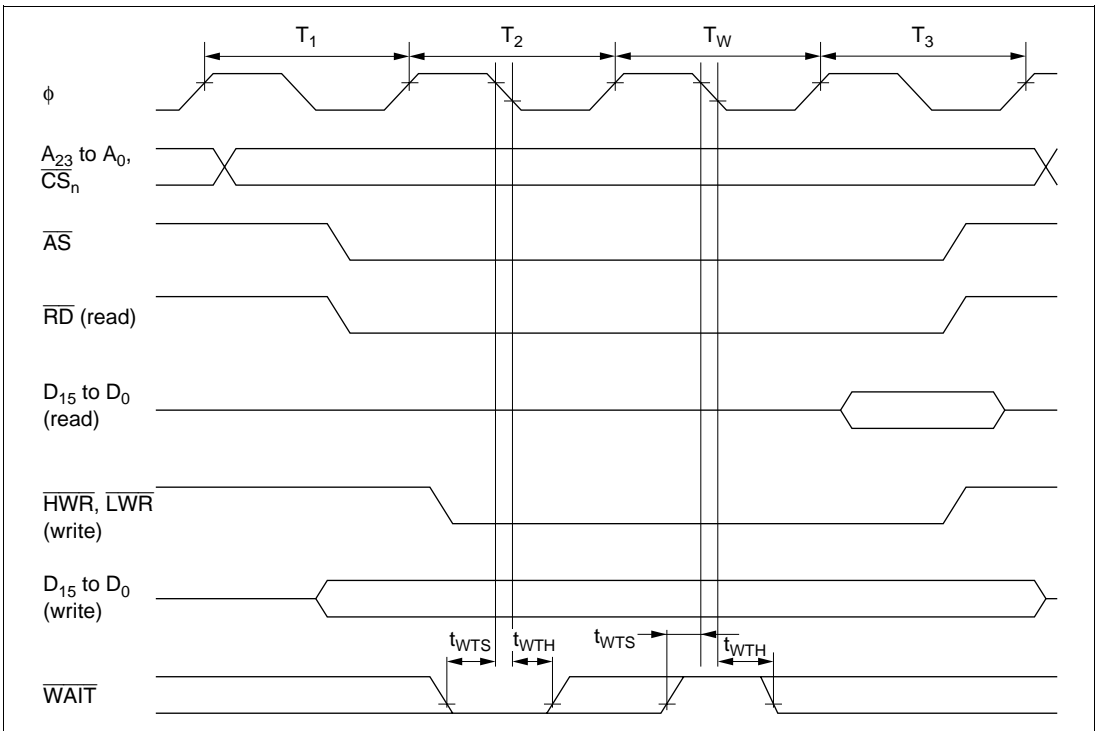
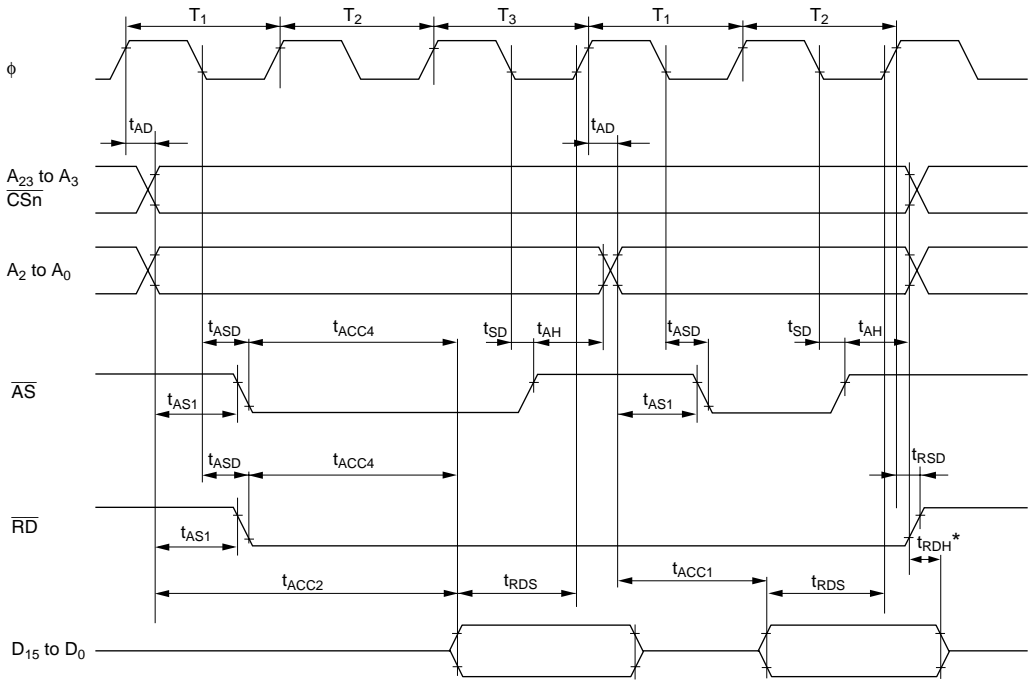

Figure 20.10 Basic Bus Cycle: Three-State Access with One Wait State



Note: * Specification from the earliest negation timing of A₂₃ to A₀, \overline{CS}_n , and \overline{RD} .

Figure 20.11 Burst ROM Access Timing: Two-State Access

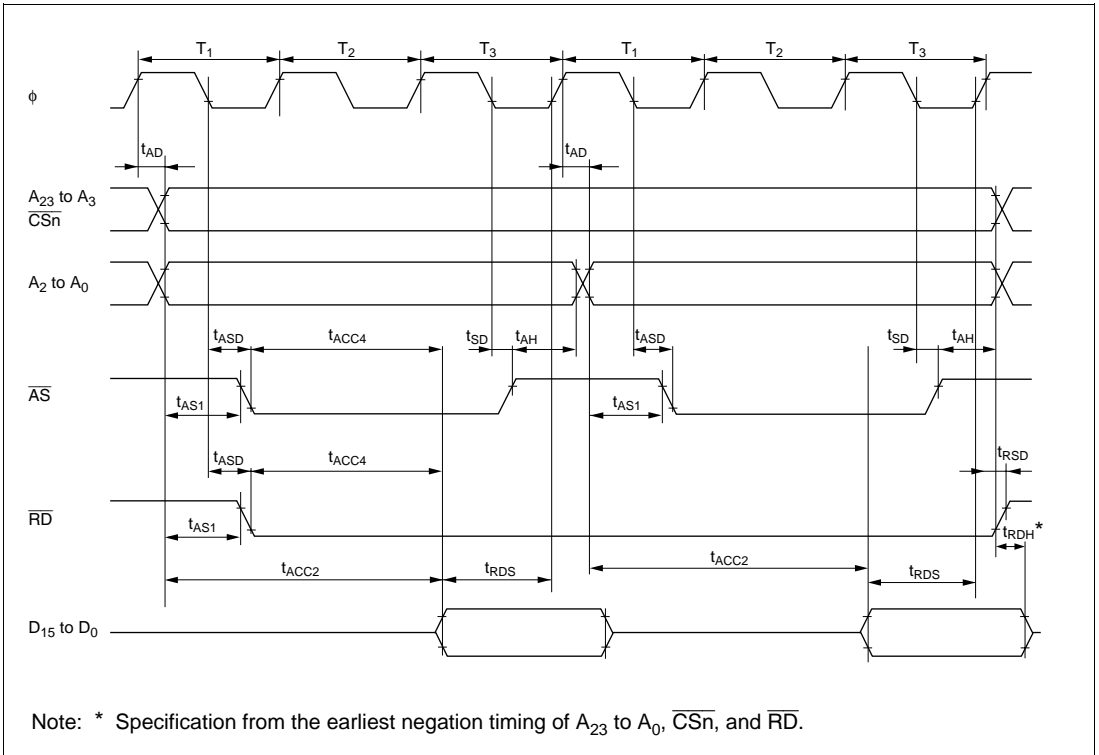

Figure 20.12 Burst ROM Access Timing: Three-State Access

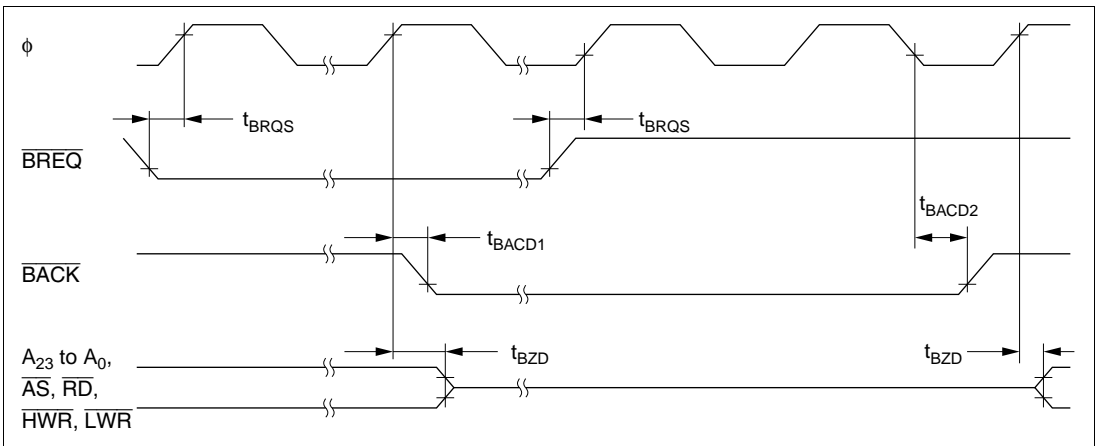
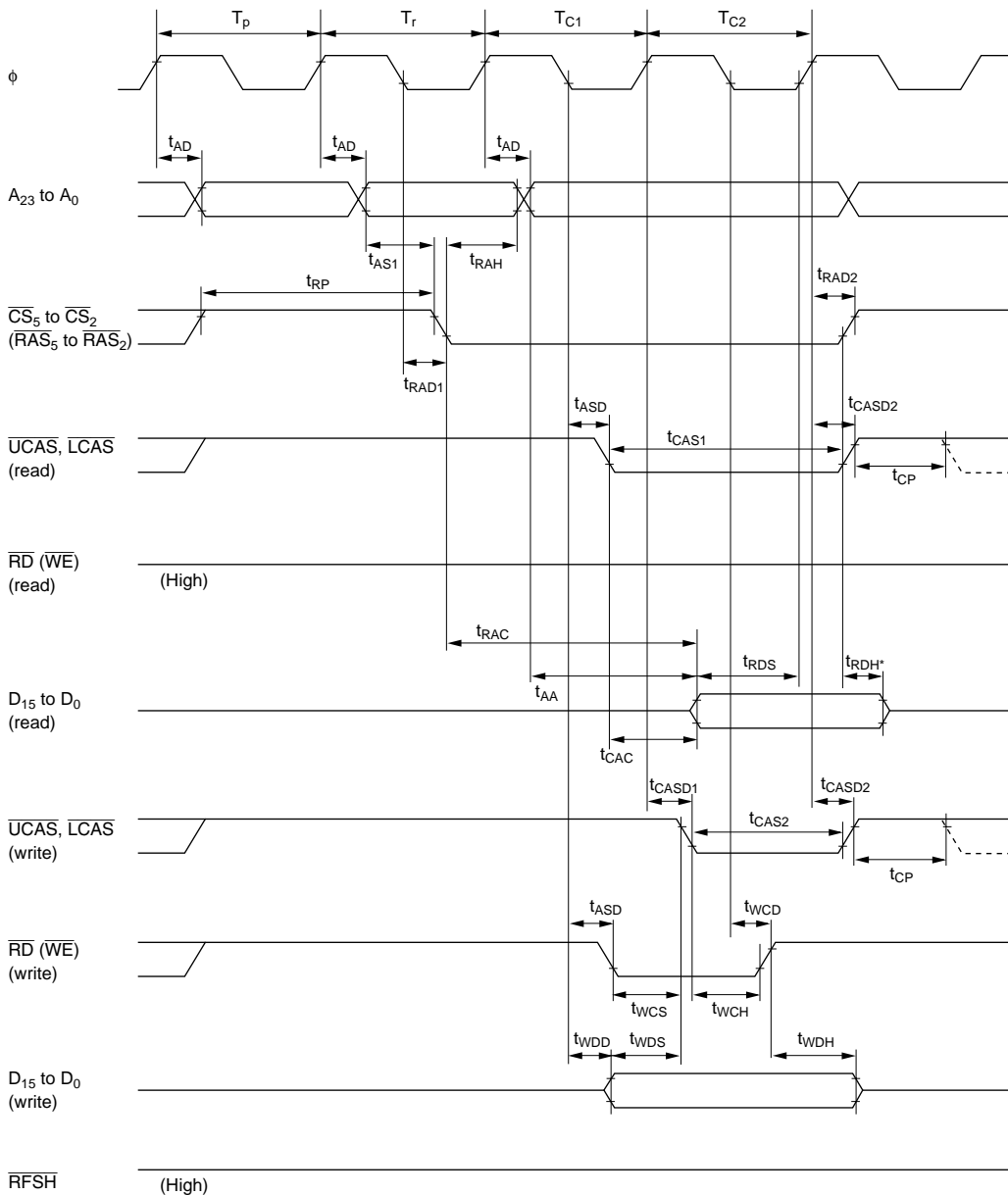

Figure 20.13 Bus-Release Mode Timing

20.3.4 DRAM Interface Bus Timing

DRAM interface bus timing is shown as follows:

- DRAM bus timing: read and write access
Figure 20.14 shows the timing of the read and write access.
- DRAM bus timing: CAS before RAS refresh
Figure 20.15 shows the timing of the CAS before RAS refresh.
- DRAM bus timing: self-refresh
Figure 20.16 shows the timing of the self-refresh.



Note: * Specification from the earliest negation timing of \overline{RAS} and \overline{CAS} .

Figure 20.14 DRAM Bus Timing (Read/Write)

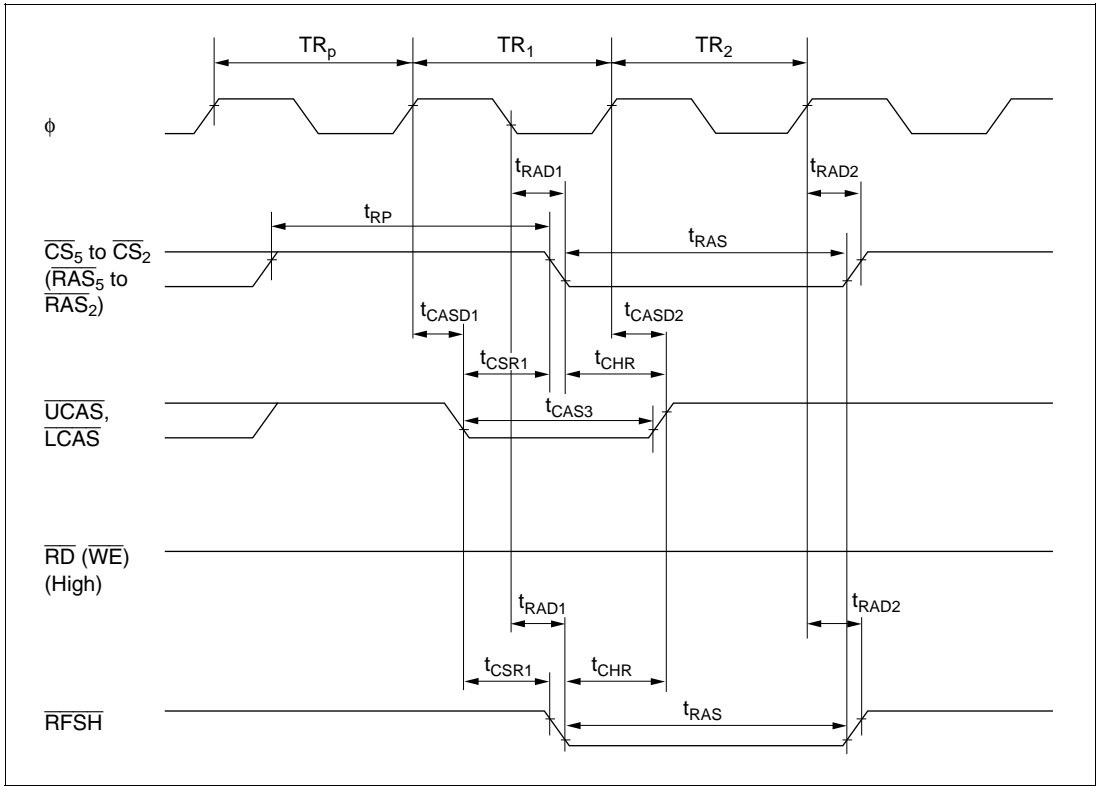

Figure 20.15 DRAM Bus Timing (CAS Before RAS Refresh)

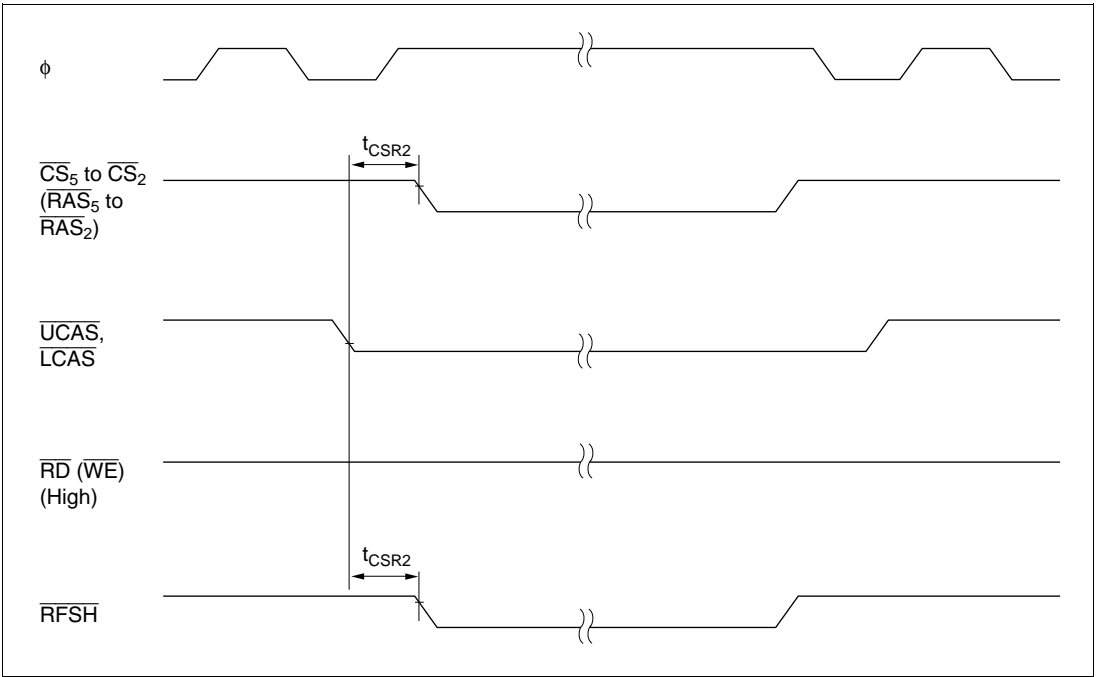

Figure 20.16 DRAM Bus Timing (Self-Refresh)

20.3.5 TPC and I/O Port Timing

Figure 20.17 shows the TPC and I/O port input/output timing.

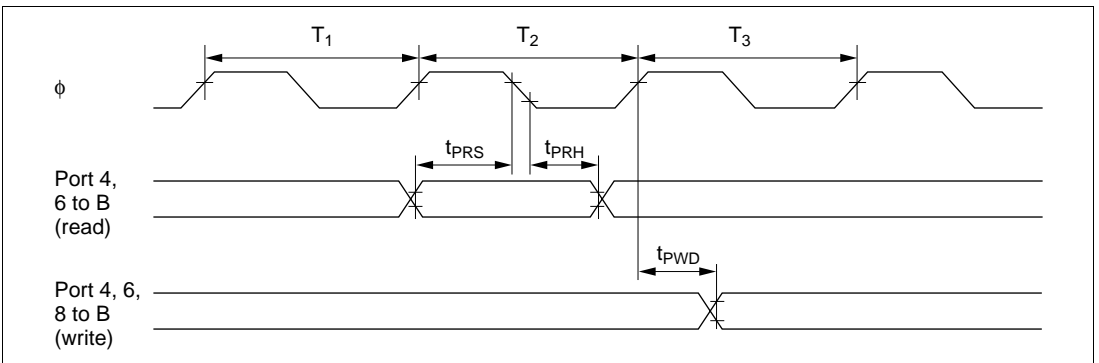

Figure 20.17 TPC and I/O Port Input/Output Timing

20.3.6 Timer Input/Output Timing

ITU timing is shown as follows:

- Timer input/output timing
Figure 20.18 shows the timer input/output timing.
- Timer external clock input timing
Figure 20.19 shows the timer external clock input timing.

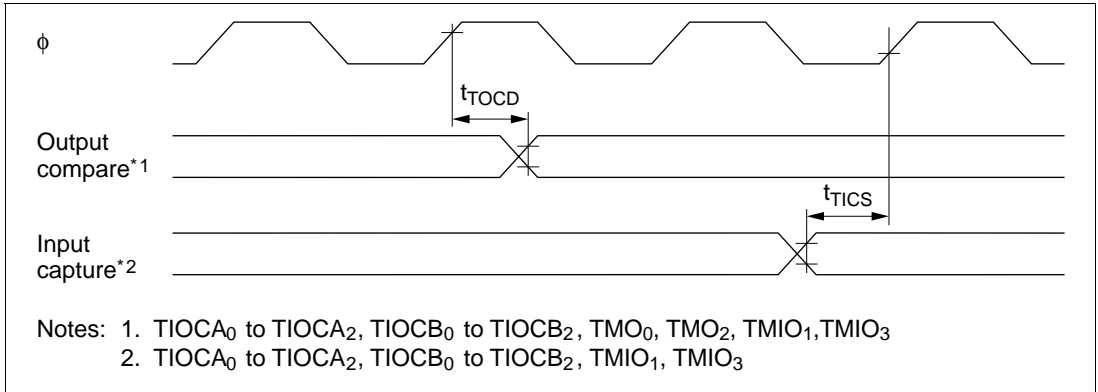

Figure 20.18 Timer Input/Output Timing

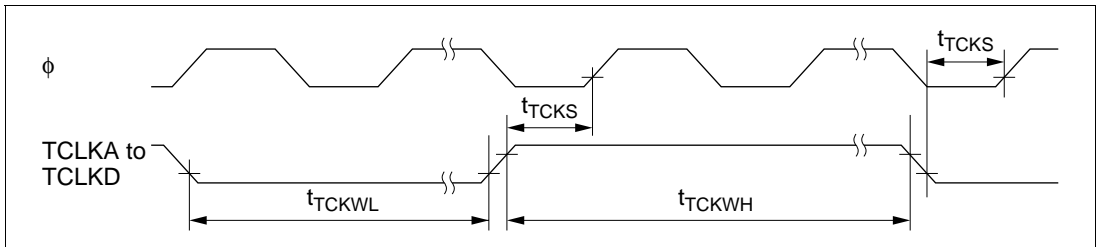

Figure 20.19 Timer External Clock Input Timing

20.3.7 SCI Input/Output Timing

SCI timing is shown as follows:

- SCI input clock timing

Figure 20.20 shows the SCI input clock timing.

- SCI input/output timing (synchronous mode)

Figure 20.21 shows the SCI input/output timing in synchronous mode.

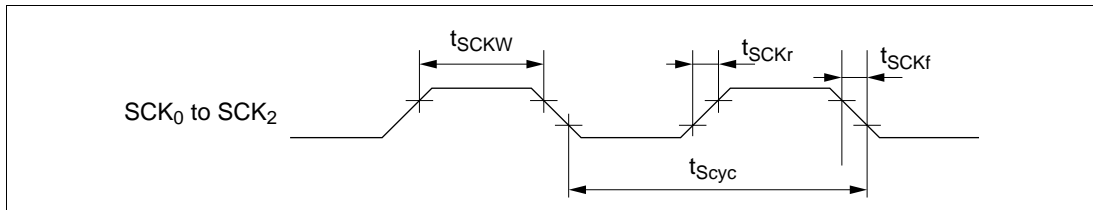

Figure 20.20 SCI Input Clock Timing

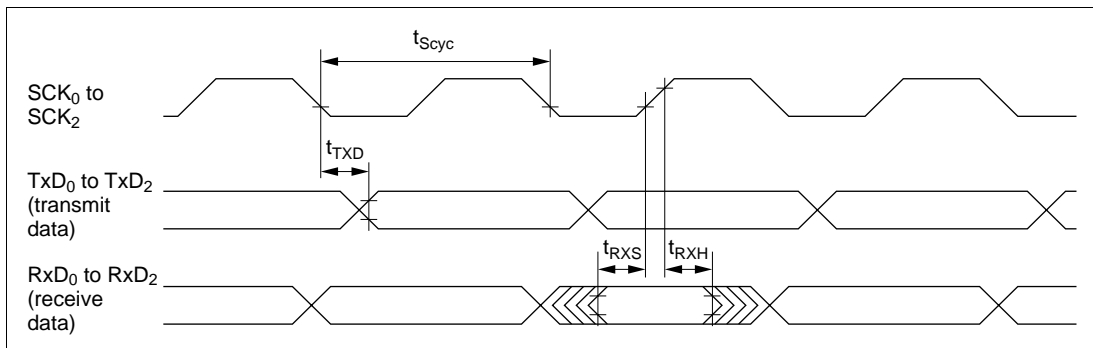

Figure 20.21 SCI Input/Output Timing in Synchronous Mode

20.3.8 DMAC Timing

DMAC timing is shown as follows.

- DMAC $\overline{\text{TEND}}$ output timing for 2 state access
Figure 20.22 shows the DMAC $\overline{\text{TEND}}$ output timing for 2 state access.
- DMAC $\overline{\text{TEND}}$ output timing for 3 state access
Figure 20.23 shows the DMAC $\overline{\text{TEND}}$ output timing for 3 state access.
- DMAC $\overline{\text{DREQ}}$ input timing
Figure 20.24 shows DMAC $\overline{\text{DREQ}}$ input timing.

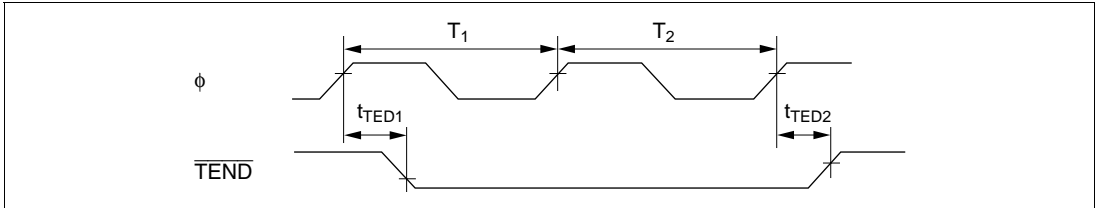

Figure 20.22 DMAC $\overline{\text{TEND}}$ Output Timing for 2 State Access

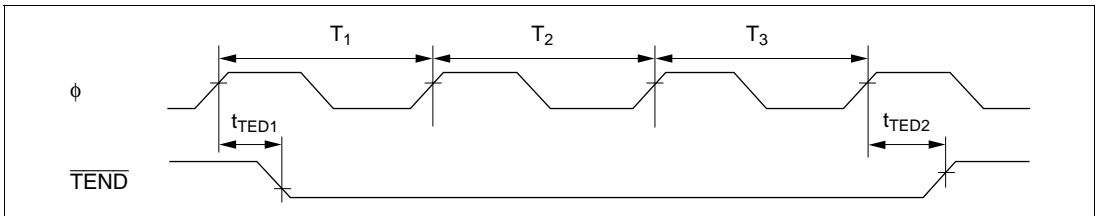

Figure 20.23 DMAC $\overline{\text{TEND}}$ Output Timing for 3 State Access

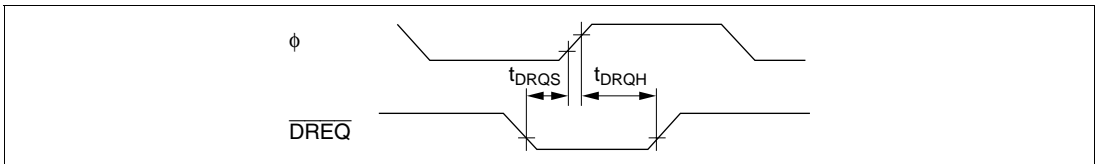

Figure 20.24 DMAC $\overline{\text{DREQ}}$ Input Timing

Appendix A Instruction Set

A.1 Instruction List

Operand Notation

Symbol	Description
Rd	General destination register
Rs	General source register
Rn	General register
ERd	General destination register (address register or 32-bit register)
ERs	General source register (address register or 32-bit register)
ERn	General register (32-bit register)
(EAd)	Destination operand
(EAs)	Source operand
PC	Program counter
SP	Stack pointer
CCR	Condition code register
N	N (negative) flag in CCR
Z	Z (zero) flag in CCR
V	V (overflow) flag in CCR
C	C (carry) flag in CCR
disp	Displacement
→	Transfer from the operand on the left to the operand on the right, or transition from the state on the left to the state on the right
+	Addition of the operands on both sides
−	Subtraction of the operand on the right from the operand on the left
×	Multiplication of the operands on both sides
÷	Division of the operand on the left by the operand on the right
^	Logical AND of the operands on both sides
∨	Logical OR of the operands on both sides
⊕	Exclusive logical OR of the operands on both sides
¬	NOT (logical complement)
(), < >	Contents of operand

Note: General registers include 8-bit registers (R0H to R7H and R0L to R7L) and 16-bit registers (R0 to R7 and E0 to E7).

Condition Code Notation

Symbol	Description
↕	Changed according to execution result
*	Undetermined (no guaranteed value)
0	Cleared to 0
1	Set to 1
—	Not affected by execution of the instruction
Δ	Varies depending on conditions, described in notes

Table A.1 Instruction Set

1. Data transfer instructions

Mnemonic	Operand Size	Addressing Mode and Instruction Length (bytes)							Operation	Condition Code						No. of States*1			
		#xx	Rn	@ERn	@ (d, ERn)	@-ERn/@ERn+	@aa	@ (d, PC)		@@aa	I	I	H	N	Z	V	C	Normal	Advanced
MOV.B #xx:8, Rd	B	2							#xx:8 → Rd8	—	—	↑	↓	0	—		2		
MOV.B Rs, Rd	B		2						Rs8 → Rd8	—	—	↑	↓	0	—		2		
MOV.B @ERs, Rd	B			2					@ERs → Rd8	—	—	↑	↓	0	—		4		
MOV.B @(d:16, ERs), Rd	B				4				@(d:16, ERs) → Rd8	—	—	↑	↓	0	—		6		
MOV.B @(d:24, ERs), Rd	B					8			@(d:24, ERs) → Rd8	—	—	↑	↓	0	—		10		
MOV.B @ERs+, Rd	B						2		@ERs → RD8 ERs32+1 → ERs32	—	—	↑	↓	0	—		6		
MOV.B @aa:8, Rd	B						2		@aa:8 → Rd8	—	—	↑	↓	0	—		4		
MOV.B @aa:16, Rd	B						4		@aa:16 → Rd8	—	—	↑	↓	0	—		6		
MOV.B @aa:24, Rd	B						6		@aa:24 → Rd8	—	—	↑	↓	0	—		8		
MOV.B Rs, @ERd	B			2					Rs8 → @ERd	—	—	↑	↓	0	—		4		
MOV.B Rs, @(d:16, ERd)	B				4				Rs8 → @(d:16, ERd)	—	—	↑	↓	0	—		6		
MOV.B Rs, @(d:24, ERd)	B					8			Rs8 → @(d:24, ERd)	—	—	↑	↓	0	—		10		
MOV.B Rs, @-ERd	B						2		ERd32-1 → ERd32 Rs8 → @ERd	—	—	↑	↓	0	—		6		
MOV.B Rs, @aa:8	B						2		Rs8 → @aa:8	—	—	↑	↓	0	—		4		
MOV.B Rs, @aa:16	B						4		Rs8 → @aa:16	—	—	↑	↓	0	—		6		
MOV.B Rs, @aa:24	B						6		Rs8 → @aa:24	—	—	↑	↓	0	—		8		
MOV.W #xx:16, Rd	W	4							#xx:16 → Rd16	—	—	↑	↓	0	—		4		
MOV.W Rs, Rd	W		2						Rs16 → Rd16	—	—	↑	↓	0	—		2		
MOV.W @ERs, Rd	W			2					@ERs → Rd16	—	—	↑	↓	0	—		4		
MOV.W @(d:16, ERs), Rd	W				4				@(d:16, ERs) → Rd16	—	—	↑	↓	0	—		6		
MOV.W @(d:24, ERs), Rd	W					8			@(d:24, ERs) → Rd16	—	—	↑	↓	0	—		10		
MOV.W @ERs+, Rd	W						2		@ERs → Rd16 ERs32+2 → @ERd32	—	—	↑	↓	0	—		6		
MOV.W @aa:16, Rd	W						4		@aa:16 → Rd16	—	—	↑	↓	0	—		6		

Mnemonic	Operand Size	Addressing Mode and Instruction Length (bytes)								Operation	Condition Code						No. of States*1	
		#xx	Rn	@ERn	@(d, ERn)	@-ERn/@ERn+	@aa	@(d, PC)	@@aa		I	H	N	Z	V	C	Normal	Advanced
MOV.W @aa:24, Rd	W					6			@aa:24 → Rd16	—	—	↑	↓	0	—	8		
MOV.W Rs, @ERd	W			2					Rs16 → @ERd	—	—	↑	↓	0	—	4		
MOV.W Rs, @(d:16, ERd)	W				4				Rs16 → @(d:16, ERd)	—	—	↑	↓	0	—	6		
MOV.W Rs, @(d:24, ERd)	W					8			Rs16 → @(d:24, ERd)	—	—	↑	↓	0	—	10		
MOV.W Rs, @-ERd	W					2			ERd32-2 → ERd32 Rs16 → @ERd	—	—	↑	↓	0	—	6		
MOV.W Rs, @aa:16	W					4			Rs16 → @aa:16	—	—	↑	↓	0	—	6		
MOV.W Rs, @aa:24	W					6			Rs16 → @aa:24	—	—	↑	↓	0	—	8		
MOV.L #xx:32, Rd	L	6							#xx:32 → Rd32	—	—	↑	↓	0	—	6		
MOV.L ERs, ERd	L		2						ERs32 → ERd32	—	—	↑	↓	0	—	2		
MOV.L @ERs, ERd	L			4					@ERs → ERd32	—	—	↑	↓	0	—	8		
MOV.L @(d:16, ERs), ERd	L				6				@(d:16, ERs) → ERd32	—	—	↑	↓	0	—	10		
MOV.L @(d:24, ERs), ERd	L					10			@(d:24, ERs) → ERd32	—	—	↑	↓	0	—	14		
MOV.L @ERs+, ERd	L					4			@ERs → ERd32 ERs32+4 → ERs32	—	—	↑	↓	0	—	10		
MOV.L @aa:16, ERd	L					6			@aa:16 → ERd32	—	—	↑	↓	0	—	10		
MOV.L @aa:24, ERd	L					8			@aa:24 → ERd32	—	—	↑	↓	0	—	12		
MOV.L ERs, @ERd	L			4					ERs32 → @ERd	—	—	↑	↓	0	—	8		
MOV.L ERs, @(d:16, ERd)	L				6				ERs32 → @(d:16, ERd)	—	—	↑	↓	0	—	10		
MOV.L ERs, @(d:24, ERd)	L					10			ERs32 → @(d:24, ERd)	—	—	↑	↓	0	—	14		
MOV.L ERs, @-ERd	L					4			ERd32-4 → ERd32 ERs32 → @ERd	—	—	↑	↓	0	—	10		
MOV.L ERs, @aa:16	L					6			ERs32 → @aa:16	—	—	↑	↓	0	—	10		
MOV.L ERs, @aa:24	L					8			ERs32 → @aa:24	—	—	↑	↓	0	—	12		
POP.W Rn W	W							2	@SP → Rn16 SP+2 → SP	—	—	↑	↓	0	—	6		
POPL ERn L	L							4	@SP → ERn32 SP+4 → SP	—	—	↑	↓	0	—	10		

Mnemonic	Operand Size	Addressing Mode and Instruction Length (bytes)								Operation	Condition Code						No. of States*1		
		#xx	Rn	@ERn	@ (d, ERn)	@-ERn/@ERn+	@aa	@ (d, PC)	@ @aa			I	H	N	Z	V	C	Normal	Advanced
PUSH.W Rn	W									2	SP-2 → SP Rn16 → @SP	—	—	↓	↓	0	—	6	
PUSH.L ERn	L									4	SP-4 → SP ERn32 → @SP	—	—	↓	↓	0	—	10	
MOVPE @aa:16, Rd	B								4		Cannot be used in the H8/3006 and H8/3007	Cannot be used in the H8/3006 and H8/3007							
MOVPE Rs, @aa:16	B								4		Cannot be used in the H8/3006 and H8/3007	Cannot be used in the H8/3006 and H8/3007							

2. Arithmetic instructions

Mnemonic	Operand Size	Addressing Mode and Instruction Length (bytes)								Operation	Condition Code						No. of States*1		
		#xx	Rn	@ERn	@ (d, ERn)	@-ERn/@ERn+	@aa	@ (d, PC)	@ @aa			I	H	N	Z	V	C	Normal	Advanced
ADD.B #xx:8, Rd	B	2									Rd8+#xx:8 → Rd8	—	↓	↓	↓	↓	↓	2	
ADD.B Rs, Rd	B	2									Rd8+Rs8 → Rd8	—	↓	↓	↓	↓	↓	2	
ADD.W #xx:16, Rd	W	4									Rd16+#xx:16 → Rd16	—	(1)	↓	↓	↓	↓	4	
ADD.W Rs, Rd	W	2									Rd16+Rs16 → Rd16	—	(1)	↓	↓	↓	↓	2	
ADD.L #xx:32, ERd	L	6									ERd32+#xx:32 → ERd32	—	(2)	↓	↓	↓	↓	6	
ADD.L ERs, ERd	L	2									ERd32+ERs32 → ERd32	—	(2)	↓	↓	↓	↓	2	
ADDX.B #xx:8, Rd	B	2									Rd8+#xx:8 +C → Rd8	—	↓	↓	(3)	↓	↓	2	
ADDX.B Rs, Rd	B	2									Rd8+Rs8 +C → Rd8	—	↓	↓	(3)	↓	↓	2	
ADDS.L #1, ERd	L	2									ERd32+1 → ERd32	—	—	—	—	—	—	2	
ADDS.L #2, ERd	L	2									ERd32+2 → ERd32	—	—	—	—	—	—	2	
ADDS.L #4, ERd	L	2									ERd32+4 → ERd32	—	—	—	—	—	—	2	
INC.B Rd	B	2									Rd8+1 → Rd8	—	—	↓	↓	↓	—	2	
INC.W #1, Rd	W	2									Rd16+1 → Rd16	—	—	↓	↓	↓	—	2	
INC.W #2, Rd	W	2									Rd16+2 → Rd16	—	—	↓	↓	↓	—	2	

Mnemonic	Operand Size	Addressing Mode and Instruction Length (bytes)								Operation	Condition Code						No. of States*1	
		#xx	Rn	@ ERn	@ (d, ERn)	@ -ERn/@ ERn+	@ aa	@ (d, PC)	@ @aa		I	H	N	Z	V	C	Normal	Advanced
INC.L #1, ERd	L	2								ERd32+1 → ERd32	—	—	↑	↑	↑	—	2	
INC.L #2, ERd	L	2								ERd32+2 → ERd32	—	—	↑	↑	↑	—	2	
DAA Rd	B	2								Rd8 decimal adjust → Rd8	—	*	↑	↑	*	—	2	
SUB.B Rs, Rd	B	2								Rd8-Rs8 → Rd8	—	↓	↓	↓	↓	↓	2	
SUB.W #xx:16, Rd	W	4								Rd16-#xx:16 → Rd16	—	(1)	↓	↓	↓	↓	4	
SUB.W Rs, Rd	W	2								Rd16-Rs16 → Rd16	—	(1)	↓	↓	↓	↓	2	
SUB.L #xx:32, ERd	L	6								ERd32-#xx:32 → ERd32	—	(2)	↓	↓	↓	↓	6	
SUB.L ERs, ERd	L	2								ERd32-ERs32 → ERd32	—	(2)	↓	↓	↓	↓	2	
SUBX.B #xx:8, Rd	B	2								Rd8-#xx:8-C → Rd8	—	↓	↓	(3)	↓	↓	2	
SUBX.B Rs, Rd	B	2								Rd8-Rs8-C → Rd8	—	↓	↓	(3)	↓	↓	2	
SUBS.L #1, ERd	L	2								ERd32-1 → ERd32	—	—	—	—	—	—	2	
SUBS.L #2, ERd	L	2								ERd32-2 → ERd32	—	—	—	—	—	—	2	
SUBS.L #4, ERd	L	2								ERd32-4 → ERd32	—	—	—	—	—	—	2	
DEC.B Rd	B	2								Rd8-1 → Rd8	—	—	↓	↓	↓	—	2	
DEC.W #1, Rd	W	2								Rd16-1 → Rd16	—	—	↓	↓	↓	—	2	
DEC.W #2, Rd	W	2								Rd16-2 → Rd16	—	—	↓	↓	↓	—	2	
DEC.L #1, ERd	L	2								ERd32-1 → ERd32	—	—	↓	↓	↓	—	2	
DEC.L #2, ERd	L	2								ERd32-2 → ERd32	—	—	↓	↓	↓	—	2	
DAS.Rd	B	2								Rd8 decimal adjust → Rd8	—	*	↑	↑	*	—	2	
MULXU.B Rs, Rd	B	2								Rd8 × Rs8 → Rd16 (unsigned multiplication)	—	—	—	—	—	—	14	
MULXU.W Rs, ERd	W	2								Rd16 × Rs16 → ERd32 (unsigned multiplication)	—	—	—	—	—	—	22	
MULXS.B Rs, Rd	B	4								Rd8 × Rs8 → Rd16 (signed multiplication)	—	—	↓	↓	—	—	16	
MULXS.W Rs, ERd	W	4								Rd16 × Rs16 → ERd32 (signed multiplication)	—	—	↓	↓	—	—	24	
DIVXU.B Rs, Rd	B	2								Rd16 ÷ Rs8 → Rd16 (RdH: remainder, RdL: quotient) (unsigned division)	—	—	(6)	(7)	—	—	14	

Mnemonic	Operand Size	Addressing Mode and Instruction Length (bytes)								Operation	Condition Code						No. of States*1		
		#xx	Rn	@ERn	@ (d, ERn)	@-ERn/@ERn+	@aa	@ (d, PC)	@@aa			I	H	N	Z	V	C	Normal	Advanced
DIVXU.W Rs, ERd	W	2								ERd32 ÷ Rs16 → ERd32 (Ed: remainder, Rd: quotient) (unsigned division)	—	—	(6)	(7)	—	—	22		
DIVXS.B Rs, Rd	B	4								Rd16 ÷ Rs8 → Rd16 (RdH: remainder, RdL: quotient) (signed division)	—	—	(8)	(7)	—	—	16		
DIVXS.W Rs, ERd	W	4								ERd32 ÷ Rs16 → ERd32 (Ed: remainder, Rd: quotient) (signed division)	—	—	(8)	(7)	—	—	24		
CMP.B #xx:8, Rd	B	2								Rd8-#xx:8	—	↓	↓	↓	↓	↓	2		
CMP.B Rs, Rd	B	2								Rd8-Rs8	—	↓	↓	↓	↓	↓	2		
CMP.W #xx:16, Rd	W	4								Rd16-#xx:16	—	(1)	↓	↓	↓	↓	4		
CMP.W Rs, Rd	W	2								Rd16-Rs16	—	(1)	↓	↓	↓	↓	2		
CMP.L #xx:32, ERd	L	6								ERd32-#xx:32	—	(2)	↓	↓	↓	↓	6		
CMP.L ERs, ERd	L	2								ERd32-ERs32	—	(2)	↓	↓	↓	↓	2		
NEG.B Rd	B	2								0-Rd8 → Rd8	—	↓	↓	↓	↓	↓	2		
NEG.W Rd	W	2								0-Rd16 → Rd16	—	↓	↓	↓	↓	↓	2		
NEG.L ERd	L	2								0-ERd32 → ERd32	—	↓	↓	↓	↓	↓	2		
EXTU.W Rd	W	2								0 → (<bits 15 to 8> of Rd16)	—	—	0	↓	0	—	2		
EXTU.L ERd	L	2								0 → (<bits 31 to 16> of ERd32)	—	—	0	↓	0	—	2		
EXTS.W Rd	W	2								(<bit 7> of Rd16) → (<bits 15 to 8> of Rd16)	—	—	↓	↓	0	—	2		
EXTS.L ERd	L	2								(<bit 15> of ERd32) → (<bits 31 to 16> of ERd32)	—	—	↓	↓	0	—	2		

4. Shift instructions

Mnemonic	Operand Size	Addressing Mode and Instruction Length (bytes)							Operation	Condition Code						No. of States*1			
		#xx	Rn	@ERn	@ (d, ERn)	@ -ERn/@ERn+	@aa	@ (d, PC)		@@aa	I	I	H	N	Z	V	C	Normal	Advanced
SHAL.B Rd	B	2								—	—	↑	↑	↑	↑	2			
SHAL.W Rd	W	2								—	—	↑	↑	↑	↑	2			
SHAL.L ERd	L	2								—	—	↑	↑	↑	↑	2			
SHAR.B Rd	B	2								—	—	↑	↑	0	↑	2			
SHAR.W Rd	W	2								—	—	↑	↑	0	↑	2			
SHAR.L ERd	L	2								—	—	↑	↑	0	↑	2			
SHLL.B Rd	B	2								—	—	↑	↑	0	↑	2			
SHLL.W Rd	W	2								—	—	↑	↑	0	↑	2			
SHLL.L ERd	L	2								—	—	↑	↑	0	↑	2			
SHLR.B Rd	B	2								—	—	↑	↑	0	↑	2			
SHLR.W Rd	W	2								—	—	↑	↑	0	↑	2			
SHLR.L ERd	L	2								—	—	↑	↑	0	↑	2			
ROTXL.B Rd	B	2								—	—	↑	↑	0	↑	2			
ROTXL.W Rd	W	2								—	—	↑	↑	0	↑	2			
ROTXL.L ERd	L	2								—	—	↑	↑	0	↑	2			
ROTXR.B Rd	B	2								—	—	↑	↑	0	↑	2			
ROTXR.W Rd	W	2								—	—	↑	↑	0	↑	2			
ROTXR.L ERd	L	2								—	—	↑	↑	0	↑	2			
ROTL.B Rd	B	2								—	—	↑	↑	0	↑	2			
ROTL.W Rd	W	2								—	—	↑	↑	0	↑	2			
ROTL.L ERd	L	2								—	—	↑	↑	0	↑	2			
ROTR.B Rd	B	2								—	—	↑	↑	0	↑	2			
ROTR.W Rd	W	2								—	—	↑	↑	0	↑	2			
ROTR.L ERd	L	2								—	—	↑	↑	0	↑	2			

5. Bit manipulation instructions

Mnemonic	Operand Size	Addressing Mode and Instruction Length (bytes)								Operation	Condition Code						No. of States*1		
		#xx	Rn	@ERn	@ (d, ERn)	@-ERn/@ERn+	@aa	@ (d, PC)	@ @aa			I	H	N	Z	V	C	Normal	Advanced
BSET #xx:3, Rd	B	2																2	
BSET #xx:3, @ERd	B		4															8	
BSET #xx:3, @aa:8	B					4												8	
BSET Rn, Rd	B	2																2	
BSET Rn, @ERd	B		4															8	
BSET Rn, @aa:8	B					4												8	
BCLR #xx:3, Rd	B	2																2	
BCLR #xx:3, @ERd	B		4															8	
BCLR #xx:3, @aa:8	B					4												8	
BCLR Rn, Rd	B	2																2	
BCLR Rn, @ERd	B		4															8	
BCLR Rn, @aa:8	B					4												8	
BNOT #xx:3, Rd	B	2																2	
BNOT #xx:3, @ERd	B		4															8	
BNOT #xx:3, @aa:8	B					4												8	
BNOT Rn, Rd	B	2																2	
BNOT Rn, @ERd	B		4															8	
BNOT Rn, @aa:8	B					4												8	
BTST #xx:3, Rd	B	2																2	
BTST #xx:3, @ERd	B		4															6	
BTST #xx:3, @aa:8	B					4												6	
BTST Rn, Rd	B	2																2	
BTST Rn, @ERd	B		4															6	
BTST Rn, @aa:8	B					4												6	
BLD #xx:3, Rd	B	2																2	

Mnemonic	Operand Size	Addressing Mode and Instruction Length (bytes)							Operation	Condition Code						No. of States*1		
		#xx	Rn	@ERn	@ (d, ERn)	@ -ERn/ @ERn+	@aa	@ (d, PC)		@aa	I	H	N	Z	V	C	Normal	Advanced
BLD #xx:3, @ERd	B		4						(#xx:3 of @ERd) → C	—	—	—	—	—	↑	6		
BLD #xx:3, @aa:8	B					4			(#xx:3 of @aa:8) → C	—	—	—	—	—	↑	6		
BILD #xx:3, Rd	B	2							¬(#xx:3 of Rd8) → C	—	—	—	—	—	↑	2		
BILD #xx:3, @ERd	B		4						¬(#xx:3 of @ERd) → C	—	—	—	—	—	↑	6		
BILD #xx:3, @aa:8	B					4			¬(#xx:3 of @aa:8) → C	—	—	—	—	—	↑	6		
BST #xx:3, Rd	B	2							C → (#xx:3 of Rd8)	—	—	—	—	—	—	2		
BST #xx:3, @ERd	B		4						C → (#xx:3 of @ERd24)	—	—	—	—	—	—	8		
BST #xx:3, @aa:8	B					4			C → (#xx:3 of @aa:8)	—	—	—	—	—	—	8		
BIST #xx:3, Rd	B	2							¬C → (#xx:3 of Rd8)	—	—	—	—	—	—	2		
BIST #xx:3, @ERd	B		4						¬C → (#xx:3 of @ERd24)	—	—	—	—	—	—	8		
BIST #xx:3, @aa:8	B					4			¬C → (#xx:3 of @aa:8)	—	—	—	—	—	—	8		
BAND #xx:3, Rd	B	2							C∧(#xx:3 of Rd8) → C	—	—	—	—	—	↑	2		
BAND #xx:3, @ERd	B		4						C∧(#xx:3 of @ERd24) → C	—	—	—	—	—	↑	6		
BAND #xx:3, @aa:8	B					4			C∧(#xx:3 of @aa:8) → C	—	—	—	—	—	↑	6		
BIAND #xx:3, Rd	B	2							C∧¬(#xx:3 of Rd8) → C	—	—	—	—	—	↑	2		
BIAND #xx:3, @ERd	B		4						C∧¬(#xx:3 of @ERd24) → C	—	—	—	—	—	↑	6		
BIAND #xx:3, @aa:8	B					4			C∧¬(#xx:3 of @aa:8) → C	—	—	—	—	—	↑	6		
BOR #xx:3, Rd	B	2							C∨(#xx:3 of Rd8) → C	—	—	—	—	—	↑	2		
BOR #xx:3, @ERd	B		4						C∨(#xx:3 of @ERd24) → C	—	—	—	—	—	↑	6		
BOR #xx:3, @aa:8	B					4			C∨(#xx:3 of @aa:8) → C	—	—	—	—	—	↑	6		
BIOR #xx:3, Rd	B	2							C∨¬(#xx:3 of Rd8) → C	—	—	—	—	—	↑	2		
BIOR #xx:3, @ERd	B		4						C∨¬(#xx:3 of @ERd24) → C	—	—	—	—	—	↑	6		
BIOR #xx:3, @aa:8	B					4			C∨¬(#xx:3 of @aa:8) → C	—	—	—	—	—	↑	6		
BXOR #xx:3, Rd	B	2							C⊕(#xx:3 of Rd8) → C	—	—	—	—	—	↑	2		
BXOR #xx:3, @ERd	B		4						C⊕(#xx:3 of @ERd24) → C	—	—	—	—	—	↑	6		
BXOR #xx:3, @aa:8	B					4			C⊕(#xx:3 of @aa:8) → C	—	—	—	—	—	↑	6		
BIXOR #xx:3, Rd	B	2							C⊕¬(#xx:3 of Rd8) → C	—	—	—	—	—	↑	2		
BIXOR #xx:3, @ERd	B		4						C⊕¬(#xx:3 of @ERd24) → C	—	—	—	—	—	↑	6		
BIXOR #xx:3, @aa:8	B					4			C⊕¬(#xx:3 of @aa:8) → C	—	—	—	—	—	↑	6		

6. Branching instructions

Mnemonic	Operand Size	Addressing Mode and Instruction Length (bytes)							Operation	Branch Condition	Condition Code						No. of States*1		
		#xx	Rn	@ERn	@(d, ERn)	@-ERn/@ERn+	@aa	@(d, PC)			@@aa	I	H	N	Z	V	C	Normal	Advanced
BRA d:8 (BT d:8)	—							2	If condition is true then PC ← PC+d else next;	Always	—	—	—	—	—	—	4		
BRA d:16 (BT d:16)	—							4			—	—	—	—	—	—	—	6	
BRN d:8 (BF d:8)	—							2		Never	—	—	—	—	—	—	4		
BRN d:16 (BF d:16)	—							4			—	—	—	—	—	—	—	6	
BHI d:8	—							2		$C \vee Z = 0$	—	—	—	—	—	—	4		
BHI d:16	—							4			—	—	—	—	—	—	—	6	
BLS d:8	—							2		$C \vee Z = 1$	—	—	—	—	—	—	4		
BLS d:16	—							4			—	—	—	—	—	—	—	6	
BCC d:8 (BHS d:8)	—							2		C = 0	—	—	—	—	—	—	4		
BCC d:16 (BHS d:16)	—							4			—	—	—	—	—	—	—	6	
BCS d:8 (BLO d:8)	—							2		C = 1	—	—	—	—	—	—	4		
BCS d:16 (BLO d:16)	—							4			—	—	—	—	—	—	—	6	
BNE d:8	—							2		Z = 0	—	—	—	—	—	—	4		
BNE d:16	—							4			—	—	—	—	—	—	—	6	
BEQ d:8	—							2		Z = 1	—	—	—	—	—	—	4		
BEQ d:16	—							4			—	—	—	—	—	—	—	6	
BVC d:8	—							2		V = 0	—	—	—	—	—	—	4		
BVC d:16	—							4			—	—	—	—	—	—	—	6	
BVS d:8	—							2		V = 1	—	—	—	—	—	—	4		
BVS d:16	—							4			—	—	—	—	—	—	—	6	
BPL d:8	—							2		N = 0	—	—	—	—	—	—	4		
BPL d:16	—							4			—	—	—	—	—	—	—	6	
BMI d:8	—							2		N = 1	—	—	—	—	—	—	4		
BMI d:16	—							4			—	—	—	—	—	—	—	6	
BGE d:8	—							2		$N \oplus V = 0$	—	—	—	—	—	—	4		
BGE d:16	—							4			—	—	—	—	—	—	—	6	
BLT d:8	—							2		$N \oplus V = 1$	—	—	—	—	—	—	4		
BLT d:16	—							4			—	—	—	—	—	—	—	6	
BGT d:8	—							2		$Z \vee (N \oplus V) = 0$	—	—	—	—	—	—	4		
BGT d:16	—							4			—	—	—	—	—	—	—	6	

7. System control instructions

Mnemonic	Addressing Mode and Instruction Length (bytes)								Operation	Condition Code						No. of States*1			
	Operand Size	#xx	Rn	@ERn	@ (d, ERn)	@-ERn/@ERn+	@aa	@ (d, PC)		@@aa		I	H	N	Z	V	C	Normal	Advanced
TRAPA #x:2	—									2	PC → @-SP CCR → @-SP <vector> → PC	1	—	—	—	—	—	14	16
RTE	—										CCR ← @SP+ PC ← @SP+	↑	↑	↑	↑	↑	↑	10	
SLEEP	—										Transition to powerdown state	—	—	—	—	—	—	2	
LDC #xx:8, CCR	B	2									#xx:8 → CCR	↑	↑	↑	↑	↑	↑	2	
LDC Rs, CCR	B		2								Rs8 → CCR	↑	↑	↑	↑	↑	↑	2	
LDC @ERs, CCR	W			4							@ERs → CCR	↑	↑	↑	↑	↑	↑	6	
LDC @(d:16, ERs), CCR	W				6						@(d:16, ERs) → CCR	↑	↑	↑	↑	↑	↑	8	
LDC @(d:24, ERs), CCR	W					10					@(d:24, ERs) → CCR	↑	↑	↑	↑	↑	↑	12	
LDC @ERs+, CCR	W						4				@ERs → CCR ERs32+2 → ERs32	↑	↑	↑	↑	↑	↑	8	
LDC @aa:16, CCR	W							6			@aa:16 → CCR	↑	↑	↑	↑	↑	↑	8	
LDC @aa:24, CCR	W								8		@aa:24 → CCR	↑	↑	↑	↑	↑	↑	10	
STC CCR, Rd	B		2								CCR → Rd8	—	—	—	—	—	—	2	
STC CCR, @ERd	W			4							CCR → @ERd	—	—	—	—	—	—	6	
STC CCR, @(d:16, ERd)	W				6						CCR → @(d:16, ERd)	—	—	—	—	—	—	8	
STC CCR, @(d:24, ERd)	W					10					CCR → @(d:24, ERd)	—	—	—	—	—	—	12	
STC CCR, @-ERd	W						4				ERd32-2 → ERd32 CCR → @ERd	—	—	—	—	—	—	8	
STC CCR, @aa:16	W							6			CCR → @aa:16	—	—	—	—	—	—	8	
STC CCR, @aa:24	W								8		CCR → @aa:24	—	—	—	—	—	—	10	
ANDC #xx:8, CCR	B	2									CCR^#xx:8 → CCR	↑	↑	↑	↑	↑	↑	2	
ORC #xx:8, CCR	B	2									CCR∨#xx:8 → CCR	↑	↑	↑	↑	↑	↑	2	
XORC #xx:8, CCR	B	2									CCR⊕#xx:8 → CCR	↑	↑	↑	↑	↑	↑	2	
NOP	—									2	PC ← PC+2	—	—	—	—	—	—	2	

8. Block transfer instructions

Mnemonic	Operand Size	Addressing Mode and Instruction Length (bytes)									Operation	Condition Code						No. of States*1	
		#xx	Rn	@ERn	@ (d, ERn)	@ -ERn/@ERn+	@aa	@ (d, PC)	@ @aa			I	H	N	Z	V	C	Normal	Advanced
EEPMOV.B	—									4	if R4L ≠ 0 repeat @R5 → @R6 R5+1 → R5 R6+1 → R6 R4L-1 → R4L until R4L=0 else next;	—	—	—	—	—	—	8+	4n ⁺²
EEPMOV.W	—									4	if R4 ≠ 0 repeat @R5 → @R6 R5+1 → R5 R6+1 → R6 R4-1 → R4 until R4=0 else next;	—	—	—	—	—	—	8+	4n ⁺²

- Notes:
- The number of states is the number of states required for execution when the instruction and its operands are located in on-chip memory. For other cases see section A.3, Normal mode is not available in the H8/3006 and H8/3007.
 - n is the value set in register R4L or R4.
 - Set to 1 when a carry or borrow occurs at bit 11; otherwise cleared to 0.
 - Set to 1 when a carry or borrow occurs at bit 27; otherwise cleared to 0.
 - Retains its previous value when the result is zero; otherwise cleared to 0.
 - Set to 1 when the adjustment produces a carry; otherwise retains its previous value.
 - The number of states required for execution of an instruction that transfers data in synchronization with the E clock is variable.
 - Set to 1 when the divisor is negative; otherwise cleared to 0.
 - Set to 1 when the divisor is zero; otherwise cleared to 0.
 - Set to 1 when the quotient is negative; otherwise cleared to 0.

A.2 Operation Code Map (1)

Instruction code:

1st byte		2nd byte	
AH	AL	BH	BL

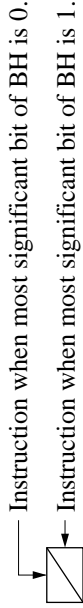

AH	AL	0	1	2	3	4	5	6	7	8	9	A	B	C	D	E	F		
0	NOP	Table A.2 (2)	Table A.2 (2)	STC	LDC	ORC	XORC	ANDC	LDC	ADD	ADD	Table A.2 (2)	Table A.2 (2)	Table A.2 (2)	MOV	ADDX	Table A.2 (2)		
1	Table A.2 (2)	Table A.2 (2)	Table A.2 (2)	OR.B	Table A.2 (2)	OR.B	XOR.B	AND.B	Table A.2 (2)	SUB	SUB	Table A.2 (2)	Table A.2 (2)	Table A.2 (2)	CMP	SUBX	Table A.2 (2)		
2	MOV.B																		
3	MOV.B																		
4	BRA	BRN	BHI	BLS	BCC	BSC	BNE	BNQ	BYC	BYC	BVS	BPL	BMI	BGE	BLT	BGT	BLE		
5	MULXU	DIVXU	MULXU	DIVXU	RTS	BSR	RTE	TRAPA	Table A.2 (2)	JMP	JMP	BSR	JSR						
6	BSET	BNOT	BCLR	BTST	OR	XOR	AND	BST	MOV										
7					BOR	BXOR	BAND	BIST	BLD	MOV	Table A.2 (2)	Table A.2 (2)	EEMOV	Table A.2 (3)					
8	ADD																		
9	ADDX																		
A	CMP																		
B	SUBX																		
C	OR																		
D	XOR																		
E	AND																		
F	MOV																		

Operation Code Map (2)

Instruction code:

1st byte		2nd byte	
AH	AL	BH	BL

BH AH/AL	0	1	2	3	4	5	6	7	8	9	A	B	C	D	E	F
01	MOV				LDC/STC				SLEEP				Table A.2 (3)	Table A.2 (3)		Table A.2 (3)
0A	INC	ADD														
0B	ADDS					INC		INC	ADDS					INC		INC
0F	DAA	MOV														
10	SHLL				SHLL				SHAL			SHAL				
11	SHLR				SHLR				SHAR			SHAR				
12	ROTXL				ROTXL				ROTL			ROTL				
13	ROTXR				ROTXR				ROTR			ROTR				
17	NOT				NOT			EXTU	NEG			NEG		EXTS		EXTS
1A	DEC	SUB														
1B	SUBS					DEC		DEC	SUBS					DEC		DEC
1F	DAS	CMP														
58	BRA	BRN	BHI	BLS	BCC	BCS	BNE	BEQ	BVC	BVS	BPL	BMI	BGE	BLT	BGT	BLE
79	MOV	ADD	CMP	SUB	OR	XOR	AND									
7A	MOV	ADD	CMP	SUB	OR	XOR	AND									

Operation Code Map (3)

Instruction code:

1st byte		2nd byte		3rd byte		4th byte	
AH	AL	BH	BL	CH	CL	DH	DL

CL	0	1	2	3	4	5	6	7	8	9	A	B	C	D	E	F
AH ALBH BLCH										LDC		LDC		LDC		LDC
01406										LDC		LDC		LDC		LDC
01C05	MULXS		MULXS													
01D05		DIVXS		DIVXS												
01F06					OR	XOR	AND									
7C06 *1																
7C07 *1																
7D06 *1	BSET	BNOT	BCLR													
7D07 *1	BSET	BNOT	BCLR													
7Eaa6 *2																
7Eaa7 *2																
7Faa6 *2	BSET	BNOT	BCLR													
7Faa7 *2	BSET	BNOT	BCLR													

Notes: 1. r is the register designation field.
 2. aa is the absolute address field.

A.3 Number of States Required for Execution

The tables in this section can be used to calculate the number of states required for instruction execution by the H8/300H CPU. Table A.4 indicates the number of instruction fetch, data read/write, and other cycles occurring in each instruction. Table A.3 indicates the number of states required per cycle according to the bus size. The number of states required for execution of an instruction can be calculated from these two tables as follows:

$$\text{Number of states} = I \times S_I + J \times S_J + K \times S_K + L \times S_L + M \times S_M + N \times S_N$$

Examples of Calculation of Number of States Required for Execution

Examples: Advanced mode, stack located in external address space, on-chip supporting modules accessed with 8-bit bus width, external devices accessed in three states with one wait state and 16-bit bus width.

BSET #0, @FFFFC7:8

From table A.4, $I = L = 2$ and $J = K = M = N = 0$

From table A.3, $S_I = 4$ and $S_L = 3$

$$\text{Number of states} = 2 \times 4 + 2 \times 3 = 14$$

JSR @@30

From table A.4, $I = J = K = 2$ and $L = M = N = 0$

From table A.3, $S_I = S_J = S_K = 4$

$$\text{Number of states} = 2 \times 4 + 2 \times 4 + 2 \times 4 = 24$$

Table A.3 Number of States per Cycle

Cycle		Access Conditions						
		On-Chip Memory	On-Chip Supporting Module		External Device			
			8-Bit Bus	16-Bit Bus	8-Bit Bus		16-Bit Bus	
				2-State Access	3-State Access	2-State Access	3-State Access	
Instruction fetch	S_I	2	6	3	4	$6 + 2m$	2	$3 + m$
Branch address read	S_J							
Stack operation	S_K							
Byte data access	S_L		3		2	$3 + m$		
Word data access	S_M		6		4	$6 + 2m$		
Internal operation	S_N	1						

Legend

m: Number of wait states inserted into external device access

Table A.4 Number of Cycles per Instruction

Instruction	Mnemonic	Instruction	Branch	Stack	Byte Data	Word Data	Internal
		Fetch	Addr. Read	Operation	Access	Access	Operation
		I	J	K	L	M	N
ADD	ADD.B #xx:8, Rd	1					
	ADD.B Rs, Rd	1					
	ADD.W #xx:16, Rd	2					
	ADD.W Rs, Rd	1					
	ADD.L #xx:32, ERd	3					
	ADD.L ERs, ERd	1					
ADDS	ADDS #1/2/4, ERd	1					
ADDX	ADDX #xx:8, Rd	1					
	ADDX Rs, Rd	1					
AND	AND.B #xx:8, Rd	1					
	AND.B Rs, Rd	1					
	AND.W #xx:16, Rd	2					
	AND.W Rs, Rd	1					
	AND.L #xx:32, ERd	3					
	AND.L ERs, ERd	2					
ANDC	ANDC #xx:8, CCR	1					
BAND	BAND #xx:3, Rd	1					
	BAND #xx:3, @	2			1		
	BAND #xx:3, @aa:8	2			1		
BCC	BRA d:8 (BT d:8)	2					
	BRN d:8 (BF d:8)	2					
	BHI d:8	2					
	BLS d:8	2					
	BCC d:8 (BHS d:8)	2					
	BCS d:8 (BLO d:8)	2					
	BNE d:8	2					
	BEQ d:8	2					
	BVC d:8	2					
	BVS d:8	2					
	BPL d:8	2					
	BMI d:8	2					
	BGE d:8	2					
	BLT d:8	2					
	BGT d:8	2					
	BLE d:8	2					

Instruction	Mnemonic	Instruction	Branch	Stack	Byte Data	Word Data	Internal
		Fetch	Addr. Read	Operation	Access	Access	Operation
		I	J	K	L	M	N
BCC	BRA d:16 (BT d:16)	2					2
	BRN d:16 (BF d:16)	2					2
	BHI d:16	2					2
	BLS d:16	2					2
	BCC d:16 (BHS d:16)	2					2
	BCS d:16 (BLO d:16)	2					2
	BNE d:16	2					2
	BEQ d:16	2					2
	BVC d:16	2					2
	BVS d:16	2					2
	BPL d:16	2					2
	BMI d:16	2					2
	BGE d:16	2					2
	BLT d:16	2					2
	BGT d:16	2					2
BLE d:16	2					2	
BCLR	BCLR #xx:3, Rd	1					
	#xx:3, @Erd	2			2		
	BCLR #xx:3, @aa:8	2			2		
	BCLR Rn, Rd	1					
	BCLR Rn, @Erd	2			2		
	BCLR Rn, @aa:8	2			2		
BIAND	BIAND #xx:3,	1					
	BIAND #xx:3, @Erd	2			1		
	BIAND #xx:3, @aa:8	2			1		
BILD	BILD #xx:3, Rd	1					
	BILD #xx:3, @Erd	2			1		
	BILD #xx:3, @aa:8	2			1		
BIOR	BIOR #xx:8, Rd	1					
	BIOR #xx:8, @	2			1		
	BIOR #xx:8, @aa:8	2			1		
BIST	BIST #xx:3, Rd	1					
	BIST #xx:3, @Erd	2			2		
	BIST #xx:3, @aa:8	2			2		
BIXOR	BIXOR #xx:3, Rd	1					
	BIXOR #xx:3, @	2			1		
	BIXOR #xx:3, @aa:8	2			1		
BLD	BLD #xx:3, Rd	1					
	BLD #xx:3, @Erd	2			1		
	BLD #xx:3, @aa:8	2			1		

Instruction	Mnemonic	Instruction	Branch	Stack	Byte Data	Word Data	Internal
		Fetch	Addr. Read	Operation	Access	Access	Operation
		I	J	K	L	M	N
BNOT	BNOT #xx:3,	1					
	BNOT #xx:3, @Erd	2			2		
	BNOT #xx:3, @aa:8	2			2		
	BNOT Rn, Rd	1					
	BNOT Rn, @Erd	2			2		
	BNOT Rn, @aa:8	2			2		
BOR	BOR #xx:3, Rd	1					
	BOR #xx:3, @Erd	2			1		
	BOR #xx:3, @aa:8	2			1		
BSET	BSET #xx:3, Rd	1					
	BSET #xx:3, @Erd	2			2		
	BSET #xx:3, @aa:8	2			2		
	BSET Rn, Rd	1					
	BSET Rn, @ERd	2			2		
	BSET Rn, @aa:8	2			2		
BSR	BSR d:8	Normal*1	2		1		
		Advanced	2		2		
	BSR d:16	Normal*1	2		1		2
		Advanced	2		2		2
BST	BST #xx:3, Rd	1					
	BST #xx:3, @Erd	2			2		
	BST #xx:3, @aa:8	2			2		
BTST	BTST #xx:3, Rd	1					
	BTST #xx:3, @Erd	2			1		
	BTST #xx:3, @aa:8	2			1		
	BTST Rn, Rd	1					
	BTST Rn, @ERd	2			1		
	BTST Rn, @aa:8	2			1		
BXOR	BXOR #xx:3, Rd	1					
	BXOR #xx:3, @Erd	2			1		
	BXOR #xx:3, @aa:8	2			1		
CMP	CMP.B #xx:8, Rd	1					
	CMP.B Rs, Rd	1					
	CMP.W #xx:16, Rd	2					
	CMP.W Rs, Rd	1					
	CMP.L #xx:32, Erd	3					
	CMP.L ERs, ERd	1					
DAA	DAA Rd	1					
DAS	DAS Rd	1					

Instruction	Mnemonic	Instruction	Branch	Stack	Byte Data	Word Data	Internal	
		Fetch	Addr. Read	Operation	Access	Access	Operation	
		I	J	K	L	M	N	
DEC	DEC.B Rd	1						
	DEC.W #1/2, Rd	1						
	DEC.L #1/2, ERd	1						
DIVXS	DIVXS.B Rs, Rd	2					12	
	DIVXS.W Rs, ERd	2					20	
DIVXU	DIVXU.B Rs, Rd	1					12	
	DIVXU.W Rs, ERd	1					20	
EEPMOV	EEPMOV.B	2			$2n + 2^{*2}$			
	EEPMOV.W	2			$2n + 2^{*2}$			
EXTS	EXTS.W Rd	1						
	EXTS.L ERd	1						
EXTU	EXTU.W Rd	1						
	EXTU.L ERd	1						
INC	INC.B Rd	1						
	INC.W #1/2, Rd	1						
	INC.L #1/2, ERd							
JMP	JMP @ERn	2						
	JMP @aa:24	2					2	
	JMP @@@a:8	Normal*1	2	1				2
		Advanced	2	2				2
JSR	JSR @ERn	Normal*1	2		1			
		Advanced	2		2			
	JSR @aa:24	Normal*1	2		1			2
		Advanced	2		2			2
	JSR @@@a:8	Normal*1	2	1	1			
		Advanced	2	2	2			
LDC	LDC #xx:8, CCR	1						
	LDC Rs, CCR	1						
	LDC @ERs, CCR	2				1		
	LDC @(d:16, ERs), CCR	3				1		
	LDC @(d:24, ERs), CCR	5				1		
	LDC @ERs+, CCR	2				1	2	
	LDC @aa:16, CCR	3				1		
	LDC @aa:24, CCR	4				1		

Instruction Mnemonic	Instruction	Branch	Stack	Byte Data	Word Data	Internal	
	Fetch	Addr. Read	Operation	Access	Access	Operation	
	I	J	K	L	M	N	
MOV	MOV.B #xx:8, Rd	1					
	MOV.B Rs, Rd	1					
	MOV.B @ERs, Rd	1			1		
	MOV.B @(d:16, ERs), Rd	2			1		
	MOV.B @(d:24, ERs), Rd	4			1		
	MOV.B @ERs+, Rd	1			1	2	
	MOV.B @aa:8, Rd	1			1		
	MOV.B @aa:16, Rd	2			1		
	MOV.B @aa:24, Rd	3			1		
	MOV.B Rs, @Erd	1			1		
	MOV.B Rs, @(d:16, Erd)	2			1		
	MOV.B Rs, @(d:24, ERd)	4			1		
	MOV.B Rs, @-Erd	1			1	2	
	MOV.B Rs, @aa:8	1			1		
	MOV.B Rs, @aa:16	2			1		
	MOV.B Rs, @aa:24	3			1		
	MOV.W #xx:16, Rd	2					
	MOV.W Rs, Rd	1					
	MOV.W @ERs, Rd	1				1	
	MOV.W @(d:16, ERs), Rd	2				1	
	MOV.W @(d:24, ERs), Rd	4				1	
	MOV.W @ERs+, Rd	1				1	2
	MOV.W @aa:16, Rd	2				1	
	MOV.W @aa:24, Rd	3				1	
	MOV.W Rs, @Erd	1				1	
	MOV.W Rs, @(d:16, Erd)	2				1	
	MOV.W Rs, @(d:24, Erd)	4				1	
	MOV.W Rs, @-Erd	1				1	2
	MOV.W Rs, @aa:16	2				1	
	MOV.W Rs, @aa:24	3				1	
	MOV.L #xx:32, Erd	3					
	MOV.L ERs, Erd	1					
	MOV.L @ERs, Erd	2				2	
	MOV.L @(d:16, ERs), Erd	3				2	
	MOV.L @(d:24, ERs), Erd	5				2	
	MOV.L @ERs+, Erd	2				2	2
MOV.L @aa:16, Erd	3				2		
MOV.L @aa:24, Erd	4				2		
MOV.L ERs, @Erd	2				2		
MOV.L ERs, @(d:16, Erd)	3				2		
MOV.L ERs, @(d:24, Erd)	5				2		
MOV.L ERs, @-Erd	2				2	2	
MOV.L ERs, @aa:16	3				2		
MOV.L ERs, @aa:24	4				2		

Instruction	Mnemonic	Instruction	Branch	Stack	Byte Data	Word Data	Internal
		Fetch	Addr. Read	Operation	Access	Access	Operation
		I	J	K	L	M	N
MOVFP	MOVFP @aa:16, Rd*3				1		
MOVTPE	MOVTPE Rs, @aa:16*3				1		
MULXS	MULXS.B Rs, Rd	2					12
	MULXS.W Rs, ERd	2					20
MULXU	MULXU.B Rs, Rd	1					12
	MULXU.W Rs, ERd	1					20
NEG	NEG.B Rd	1					
	NEG.W Rd	1					
	NEG.L ERd	1					
NOP	NOP	1					
NOT	NOT.B Rd	1					
	NOT.W Rd	1					
	NOT.L ERd	1					
OR	OR.B #xx:8, Rd	1					
	OR.B Rs, Rd	1					
	OR.W #xx:16, Rd	2					
	OR.W Rs, Rd	1					
	OR.L #xx:32, ERd	3					
	OR.L ERs, ERd	2					
ORC	ORC #xx:8, CCR	1					
POP	POP.W Rn	1				1	2
	POP.L ERn	2				2	2
PUSH	PUSH.W Rn	1				1	2
	PUSH.L ERn	2				2	2
ROTL	ROTL.B Rd	1					
	ROTL.W Rd	1					
	ROTL.L ERd	1					
ROTR	ROTR.B Rd	1					
	ROTR.W Rd	1					
	ROTR.L ERd	1					
ROTXL	ROTXL.B Rd	1					
	ROTXL.W Rd	1					
	ROTXL.L ERd	1					
ROTXR	ROTXR.B Rd	1					
	ROTXR.W Rd	1					
	ROTXR.L ERd	1					
RTE	RTE	2		2		2	

Instruction Mnemonic		Instruction Fetch I	Branch Addr. Read J	Stack Operation K	Byte Data Access L	Word Data Access M	Internal Operation N
RTS	RTS	Normal* ¹	2		1		2
		Advanced	2		2		2
SHAL	SHAL.B Rd	1					
	SHAL.W Rd	1					
	SHAL.L ERd	1					
SHAR	SHAR.B Rd	1					
	SHAR.W Rd	1					
	SHAR.L ERd	1					
SHLL	SHLL.B Rd	1					
	SHLL.W Rd	1					
	SHLL.L ERd	1					
SHLR	SHLR.B Rd	1					
	SHLR.W Rd	1					
	SHLR.L ERd	1					
SLEEP	SLEEP	1					
STC	STC CCR, Rd	1					
	STC CCR, @Erd	2				1	
	STC CCR, @(d:16, Erd)	3				1	
	STC CCR, @(d:24, Erd)	5				1	
	STC CCR, @-Erd	2				1	2
	STC CCR, @aa:16	3				1	
	STC CCR, @aa:24	4				1	
SUB	SUB.B Rs, Rd	1					
	SUB.W #xx:16, Rd	2					
	SUB.W Rs, Rd	1					
	SUB.L #xx:32, Erd	3					
	SUB.L ERs, ERd	1					
SUBS	SUBS #1/2/4, ERd	1					
SUBX	SUBX #xx:8, Rd	1					
	SUBX Rs, Rd	1					
TRAPA	TRAPA #x:2	Normal* ¹	2	1	2		4
		Advanced	2	2	2		4
XOR	XOR.B #xx:8, Rd	1					
	XOR.B Rs, Rd	1					
	XOR.W #xx:16, Rd	2					
	XOR.W Rs, Rd	1					
	XOR.L #xx:32, Erd	3					
	XOR.L ERs, ERd	2					
XORC	XORC #xx:8, CCR	1					

Notes: 1. n is the value set in register R4L or R4. The source and destination are accessed n + 1 times each.

2. Not available in the H8/3006 and H8/3007.

Appendix B Internal I/O Registers

B.1 Addresses

Address (Low)	Register Name	Data Bus Width	Register Name								Module name
			Bit 7	Bit 6	Bit 5	Bit 4	Bit 3	Bit 2	Bit 1	Bit 0	
H'EE000	Reserved area (access prohibited)										
H'EE001											
H'EE002											
H'EE003	P4DDR	8	P4 ₇ DDR	P4 ₆ DDR	P4 ₅ DDR	P4 ₄ DDR	P4 ₃ DDR	P4 ₂ DDR	P4 ₁ DDR	P4 ₀ DDR	Port 4
H'EE004	Reserved area (access prohibited)										
H'EE005	P6DDR	8	—	P6 ₆ DDR	P6 ₅ DDR	P6 ₄ DDR	P6 ₃ DDR	P6 ₂ DDR	P6 ₁ DDR	P6 ₀ DDR	Port 6
H'EE006	—	—	—	—	—	—	—	—	—	—	—
H'EE007	P8DDR	8	—	—	—	P8 ₄ DDR	P8 ₃ DDR	P8 ₂ DDR	P8 ₁ DDR	P8 ₀ DDR	Port 8
H'EE008	P9DDR	8	—	—	P9 ₅ DDR	P9 ₄ DDR	P9 ₃ DDR	P9 ₂ DDR	P9 ₁ DDR	P9 ₀ DDR	Port 9
H'EE009	PADDR	8	PA ₇ DDR	PA ₆ DDR	PA ₅ DDR	PA ₄ DDR	PA ₃ DDR	PA ₂ DDR	PA ₁ DDR	PA ₀ DDR	Port A
H'EE00A	PBDDR	8	PB ₇ DDR	PB ₆ DDR	PB ₅ DDR	PB ₄ DDR	PB ₃ DDR	PB ₂ DDR	PB ₁ DDR	PB ₀ DDR	Port B
H'EE00B	—	—	—	—	—	—	—	—	—	—	—
H'EE00C	—	—	—	—	—	—	—	—	—	—	—
H'EE00D	—	—	—	—	—	—	—	—	—	—	—
H'EE00E	—	—	—	—	—	—	—	—	—	—	—
H'EE00F	—	—	—	—	—	—	—	—	—	—	—
H'EE010	—	—	—	—	—	—	—	—	—	—	—
H'EE011	MDCR	8	—	—	—	—	—	MDS2	MDS1	MDS0	System control
H'EE012	SYSCR	8	SSBY	STS2	STS1	STS0	UE	NMIEG	SSOE	RAME	System control
H'EE013	BRCR	8	A23E	A22E	A21E	A20E	—	—	—	BRLE	Bus controller
H'EE014	ISCR	8	—	—	IRQ5SC	IRQ4SC	IRQ3SC	IRQ2SC	IRQ1SC	IRQ0SC	Interrupt controller
H'EE015	IER	8	—	—	IRQ5E	IRQ4E	IRQ3E	IRQ2E	IRQ1E	IRQ0E	Interrupt controller
H'EE016	ISR	8	—	—	IRQ5F	IRQ4F	IRQ3F	IRQ2F	IRQ1F	IRQ0F	Interrupt controller
H'EE017	—	—	—	—	—	—	—	—	—	—	—
H'EE018	IPRA	8	IPRA7	IPRA6	IPRA5	IPRA4	IPRA3	IPRA2	IPRA1	IPRA0	—
H'EE019	IPRB	8	IPRB7	IPRB6	IPRB5	—	IPRB3	IPRB2	IPRB1	—	—
H'EE01A	DASTCR	8	—	—	—	—	—	—	—	DASTE	D/A converter
H'EE01B	DIVCR	8	—	—	—	—	—	—	DIV1	DIV0	System control
H'EE01C	MSTCRH	8	PSTOP	—	—	—	—	MSTPH2	MSTPH1	MSTPH0	System control
H'EE01D	MSTCRL	8	MSTPL7	—	MSTPL5	MSTPL4	MSTPL3	MSTPL2	—	MSTPL0	—
H'EE01E	—	—	—	—	—	—	—	—	—	—	—
H'EE01F	CSCR	8	CS7E	CS6E	CS5E	CS4E	—	—	—	—	Bus controller

Address (Low)	Register Name	Data Bus Width	Register Name								Module name
			Bit 7	Bit 6	Bit 5	Bit 4	Bit 3	Bit 2	Bit 1	Bit 0	
H'EE020	ABWCR	8	ABW7	ABW6	ABW5	ABW4	ABW3	ABW2	ABW1	ABW0	Bus controller
H'EE021	ASTCR	8	AST7	AST6	AST5	AST4	AST3	AST2	AST1	AST0	
H'EE022	WCRH	8	W71	W70	W61	W60	W51	W50	W41	W40	
H'EE023	WCRL	8	W31	W30	W21	W20	W11	W10	W01	W00	
H'EE024	BCR	8	ICIS1	ICIS0	BROME	BRSTS1	BRSTS0	—	RDEA	WAITE	
H'EE025	—	—	—	—	—	—	—	—	—	—	DRAM interface
H'EE026	DRCRA	8	DRAS2	DRAS1	DRAS0	—	BE	RDM	SRFMD	RFSHE	
H'EE027	DRCRB	8	MXC1	MXC0	CSEL	RCYCE	—	TPC	RCW	RLW	
H'EE028	RTMCSR	8	CMF	CMIE	CKS2	CKS1	CKS0	—	—	—	
H'EE029	RTCNT	8	—	—	—	—	—	—	—	—	
H'EE02A	RTCOR	8	—	—	—	—	—	—	—	—	Reserved area (access prohibited)
H'EE02B											
H'EE02C											
H'EE02D											
H'EE02E											
H'EE02F											
H'EE030	—	—	—	—	—	—	—	—	—	—	Reserved area (access prohibited)
H'EE031	—	—	—	—	—	—	—	—	—	—	
H'EE032	—	—	—	—	—	—	—	—	—	—	
H'EE033	—	—	—	—	—	—	—	—	—	—	
H'EE034	—	—	—	—	—	—	—	—	—	—	
H'EE035	—	—	—	—	—	—	—	—	—	—	
H'EE036	—	—	—	—	—	—	—	—	—	—	
H'EE037	—	—	—	—	—	—	—	—	—	—	
H'EE038	—	—	—	—	—	—	—	—	—	—	
H'EE039	—	—	—	—	—	—	—	—	—	—	
H'EE03A	—	—	—	—	—	—	—	—	—	—	
H'EE03B	—	—	—	—	—	—	—	—	—	—	
H'EE03C											
H'EE03D	—	—	—	—	—	—	—	—	—	—	Port 4
H'EE03E	P4PCR	8	P4 ₇ PCR	P4 ₆ PCR	P4 ₅ PCR	P4 ₄ PCR	P4 ₃ PCR	P4 ₂ PCR	P4 ₁ PCR	P4 ₀ PCR	
H'EE03F											

Address (Low)	Register Name	Data Bus Width	Register Name								Module name
			Bit 7	Bit 6	Bit 5	Bit 4	Bit 3	Bit 2	Bit 1	Bit 0	
H'FFF20	MAR0AR	8									DMAC channel 0A
H'FFF21	MAR0AE	8									
H'FFF22	MAR0AH	8									
H'FFF23	MAR0AL	8									
H'FFF24	ETCR0AH	8									
H'FFF25	ETCR0AL	8									
H'FFF26	IOAR0A	8									
H'FFF27	DTCR0A	8	DTE	DTSZ	DTID	RPE	DTIE	DTS2	DTS1	DTS0	Short address mode
			DTE	DTSZ	SAID	SAIDE	DTIE	DTS2A	DTS1A	DTS0A	Full address mode
H'FFF28	MAR0BR	8									DMAC channel 0B
H'FFF29	MAR0BE	8									
H'FFF2A	MAR0BH	8									
H'FFF2B	MAR0BL	8									
H'FFF2C	ETCR0BH	8									
H'FFF2D	ETCR0BL	8									
H'FFF2E	IOAR0B	8									
H'FFF2F	DTCR0B	8	DTE	DTSZ	DTID	RPE	DTIE	DTS2	DTS1	DTS0	Short address mode
			DTME	—	DAID	DAIDE	TMS	DTS2B	DTS1B	DTS0B	Full address mode
H'FFF30	MAR1AR	8									DMAC channel 1A
H'FFF31	MAR1AE	8									
H'FFF32	MAR1AH	8									
H'FFF33	MAR1AL	8									
H'FFF34	ETCR1AH	8									
H'FFF35	ETCR1AL	8									
H'FFF36	IOAR1A	8									
H'FFF37	DTCR1A	8	DTE	DTSZ	DTID	RPE	DTIE	DTS2	DTS1	DTS0	Short address mode
			DTE	DTSZ	SAID	SAIDE	DTIE	DTS2A	DTS1A	DTS0A	Full address mode
H'FFF38	MAR1BR	8									DMAC channel 1B
H'FFF39	MAR1BE	8									
H'FFF3A	MAR1BH	8									
H'FFF3B	MAR1BL	8									
H'FFF3C	ETCR1BH	8									
H'FFF3D	ETCR1BL	8									
H'FFF3E	IOAR1B	8									
H'FFF3F	DTCR1B	8	DTE	DTSZ	DTID	RPE	DTIE	DTS2	DTS1	DTS0	Short address mode
			DTME	—	DAID	DAIDE	TMS	DTS2B	DTS1B	DTS0B	Full address mode

Address (Low)	Register Name	Data Bus Width	Register Name								Module name
			Bit 7	Bit 6	Bit 5	Bit 4	Bit 3	Bit 2	Bit 1	Bit 0	
H'FFF40	—	—	—	—	—	—	—	—	—	—	—
H'FFF41	—	—	—	—	—	—	—	—	—	—	—
H'FFF42	—	—	—	—	—	—	—	—	—	—	—
H'FFF43	—	—	—	—	—	—	—	—	—	—	—
H'FFF44	—	—	—	—	—	—	—	—	—	—	—
H'FFF45	—	—	—	—	—	—	—	—	—	—	—
H'FFF46	—	—	—	—	—	—	—	—	—	—	—
H'FFF47	—	—	—	—	—	—	—	—	—	—	—
H'FFF48	—	—	—	—	—	—	—	—	—	—	—
H'FFF49	—	—	—	—	—	—	—	—	—	—	—
H'FFF4A	—	—	—	—	—	—	—	—	—	—	—
H'FFF4B	—	—	—	—	—	—	—	—	—	—	—
H'FFF4C	—	—	—	—	—	—	—	—	—	—	—
H'FFF4D	—	—	—	—	—	—	—	—	—	—	—
H'FFF4E	—	—	—	—	—	—	—	—	—	—	—
H'FFF4F	—	—	—	—	—	—	—	—	—	—	—
H'FFF50	—	—	—	—	—	—	—	—	—	—	—
H'FFF51	—	—	—	—	—	—	—	—	—	—	—
H'FFF52	—	—	—	—	—	—	—	—	—	—	—
H'FFF53	—	—	—	—	—	—	—	—	—	—	—
H'FFF54	—	—	—	—	—	—	—	—	—	—	—
H'FFF55	—	—	—	—	—	—	—	—	—	—	—
H'FFF56	—	—	—	—	—	—	—	—	—	—	—
H'FFF57	—	—	—	—	—	—	—	—	—	—	—
H'FFF58	—	—	—	—	—	—	—	—	—	—	—
H'FFF59	—	—	—	—	—	—	—	—	—	—	—
H'FFF5A	—	—	—	—	—	—	—	—	—	—	—
H'FFF5B	—	—	—	—	—	—	—	—	—	—	—
H'FFF5C	—	—	—	—	—	—	—	—	—	—	—
H'FFF5D	—	—	—	—	—	—	—	—	—	—	—
H'FFF5E	—	—	—	—	—	—	—	—	—	—	—
H'FFF5F	—	—	—	—	—	—	—	—	—	—	—

Address (Low)	Register Name	Data Bus Width	Register Name								Module name	
			Bit 7	Bit 6	Bit 5	Bit 4	Bit 3	Bit 2	Bit 1	Bit 0		
H'FFF60	TSTR	8	—	—	—	—	—	—	STR2	STR1	STR0	16-bit timer, (all channels)
H'FFF61	TSNC	8	—	—	—	—	—	—	SYNC2	SYNC1	SYNC0	
H'FFF62	TMDR	8	—	MDF	FDIR	—	—	—	PWM2	PWM1	PWM0	
H'FFF63	TOLR	8	—	—	TOB2	TOA2	TOB1	—	TOA1	TOB0	TOA0	
H'FFF64	TISRA	8	—	IMIEA2	IMIEA1	IMIEA0	—	—	IMFA2	IMFA1	IMFA0	
H'FFF65	TISRB	8	—	IMIEB2	IMIEB1	IMIEB0	—	—	IMFB2	IMFB1	IMFB0	
H'FFF66	TISRC	8	—	OVIE2	OVIE1	OVIE0	—	—	OVF2	OVF1	OVF0	
H'FFF67												
H'FFF68	16TCR0	8	—	CCLR1	CCLR0	CKEG1	CKEG0	—	TPSC2	TPSC1	TPSC0	16-bit timer channel 0
H'FFF69	TIOR0	8	—	IOB2	IOB1	IOB0	—	—	IOA2	IOA1	IOA0	
H'FFF6A	16TCNT0H	16										
H'FFF6B	16TCNT0L											
H'FFF6C	GRA0H	16										
H'FFF6D	GRA0L											
H'FFF6E	GRB0H	16										
H'FFF6F	GRB0L											
H'FFF70	16TCR1	8	—	CCLR1	CCLR0	CKEG1	CKEG0	—	TPSC2	TPSC1	TPSC0	16-bit timer channel 1
H'FFF71	TIOR1	8	—	IOB2	IOB1	IOB0	—	—	IOA2	IOA1	IOA0	
H'FFF72	16TCNT1H	16										
H'FFF73	16TCNT1L											
H'FFF74	GRA1H	16										
H'FFF75	GRA1L											
H'FFF76	GRB1H	16										
H'FFF77	GRB1L											
H'FFF78	16TCR2	8	—	CCLR1	CCLR0	CKEG1	CKEG0	—	TPSC2	TPSC1	TPSC0	16-bit timer channel 2
H'FFF79	TIOR2	8	—	IOB2	IOB1	IOB0	—	—	IOA2	IOA1	IOA0	
H'FFF7A	16TCNT2H	16										
H'FFF7B	16TCNT2L											
H'FFF7C	GRA2H	16										
H'FFF7D	GRA2L											
H'FFF7E	GRB2H	16										
H'FFF7F	GRB2L											

Address (Low)	Register Name	Data Bus Width	Register Name								Module name
			Bit 7	Bit 6	Bit 5	Bit 4	Bit 3	Bit 2	Bit 1	Bit 0	
H'FFF80	8TCR0	8	CMIEB	CMIEA	OVIE	CCLR1	CCLR0	CKS2	CKS1	CKS0	8-bit timer channels 0 and 1
H'FFF81	8TCR1	8	CMIEB	CMIEA	OVIE	CCLR1	CCLR0	CKS2	CKS1	CKS0	
H'FFF82	8TCSR0	8	CMFB	CMFA	OVF	ADTE	OIS3	OIS2	OS1	OS0	
H'FFF83	8TCSR1	8	CMFB	CMFA	OVF	ICE	OIS3	OIS2	OS1	OS0	
H'FFF84	TCORA0	8									
H'FFF85	TCORA1	8									
H'FFF86	TCORB0	8									
H'FFF87	TCORB1	8									
H'FFF88	8TCNT0	8									
H'FFF89	8TCNT1	8									
H'FFF8A	—	—	—	—	—	—	—	—	—	—	
H'FFF8B	—	—	—	—	—	—	—	—	—	—	
H'FFF8C	TCSR* ¹	8	OVF	WT/I \bar{T}	TME	—	—	CKS2	CKS1	CKS0	WDT
H'FFF8D	TCNT* ¹	8									
H'FFF8E	—	—	—	—	—	—	—	—	—	—	
H'FFF8F	RSTCSR * ¹	8	WRST	RSTOE	—	—	—	—	—	—	
H'FFF90	8TCR2	8	CMIEB	CMIEA	OVIE	CCLR1	CCLR0	CKS2	CKS1	CKS0	8-bit timer channels 2 and 3
H'FFF91	8TCR3	8	CMIEB	CMIEA	OVIE	CCLR1	CCLR0	CKS2	CKS1	CKS0	
H'FFF92	8TCSR2	8	CMFB	CMFA	OVF	—	OIS3	OIS2	OS1	OS0	
H'FFF93	8TCSR3	8	CMFB	CMFA	OVF	ICE	OIS3	OIS2	OS1	OS0	
H'FFF94	TCORA2	8									
H'FFF95	TCORA3	8									
H'FFF96	TCORB2	8									
H'FFF97	TCORB3	8									
H'FFF98	8TCNT2	8									
H'FFF99	8TCNT3	8									
H'FFF9A	—	—	—	—	—	—	—	—	—	—	
H'FFF9B	—	—	—	—	—	—	—	—	—	—	
H'FFF9C	DADR0	8									D/A converter
H'FFF9D	DADR1	8									
H'FFF9E	DACR	8	DAOE1	DAOE0	DAE	—	—	—	—	—	
H'FFF9F	—	8	—	—	—	—	—	—	—	—	

Address (Low)	Register Name	Data Bus Width	Register Name								Module name
			Bit 7	Bit 6	Bit 5	Bit 4	Bit 3	Bit 2	Bit 1	Bit 0	
H'FFFA0	TPMR	8	—	—	—	—	G3NOV	G2NOV	G1NOV	G0NOV	TPC
H'FFFA1	TPCR	8	G3CMS1	G3CMS0	G2CMS1	G2CMS0	G1CMS1	G1CMS0	G0CMS1	G0CMS0	
H'FFFA2	NDERB	8	NDER15	NDER14	NDER13	NDER12	NDER11	NDER10	NDER9	NDER8	
H'FFFA3	NDERA	8	NDER7	NDER6	NDER5	NDER4	NDER3	NDER2	NDER1	NDER0	
H'FFFA4	NDRB* ²	8	NDER15	NDER14	NDER13	NDER12	NDER11	NDER10	NDER9	NDER8	
			NDER15	NDER14	NDER13	NDER12	—	—	—	—	
H'FFFA5	NDRA* ²	8	NDER7	NDER6	NDER5	NDER4	NDER3	NDER2	NDER1	NDER0	
			NDER7	NDER6	NDER5	NDER4	—	—	—	—	
H'FFFA6	NDRB* ²	8	—	—	—	—	—	—	—	—	
			—	—	—	—	NDER11	NDER10	NDER9	NDER8	
H'FFFA7	NDRA* ²	8	—	—	—	—	—	—	—	—	
			—	—	—	—	NDER3	NDER2	NDER1	NDER0	
H'FFFA8	—	—	—	—	—	—	—	—	—	—	
H'FFFA9	—	—	—	—	—	—	—	—	—	—	
H'FFFAA	—	—	—	—	—	—	—	—	—	—	
H'FFFAB	—	—	—	—	—	—	—	—	—	—	
H'FFFAC	—	—	—	—	—	—	—	—	—	—	
H'FFFAD	—	—	—	—	—	—	—	—	—	—	
H'FFFAE	—	—	—	—	—	—	—	—	—	—	
H'FFFAF	—	—	—	—	—	—	—	—	—	—	
H'FFFB0	SMR	8	C/ \bar{A}	CHR	PE	O/ \bar{E}	STOP	MP	CKS1	CKS0	SCI channel 0
H'FFFB1	BRR	8									
H'FFFB2	SCR	8	TIE	RIE	TE	RE	MPIE	TEIE	CKE1	CKE0	
H'FFFB3	TDR	8									
H'FFFB4	SSR	8	TDRE	RDRF	ORER	FER/ERS	PER	TEND	MPB	MPBT	
H'FFFB5	RDR	8									
H'FFFB6	SCMR	8	—	—	—	—	SDIR	SINV	—	SMIF	
H'FFFB7	Reserved area (access prohibited)										
H'FFFB8	SMR	8	C/ \bar{A}	CHR	PE	O/ \bar{E}	STOP	MP	CKS1	CKS0	SCI channel 1
H'FFFB9	BRR	8									
H'FFBBA	SCR	8	TIE	RIE	TE	RE	MPIE	TEIE	CKE1	CKE0	
H'FFBBB	TDR	8									
H'FFBBC	SSR	8	TDRE	RDRF	ORER	FER/ERS	PER	TEND	MPB	MPBT	
H'FFBBD	RDR	8									
H'FFBBE	SCMR	8	—	—	—	—	SDIR	SINV	—	SMIF	
H'FFBBF	Reserved area (access prohibited)										

Address (Low)	Register Name	Data Bus Width	Register Name								Module name
			Bit 7	Bit 6	Bit 5	Bit 4	Bit 3	Bit 2	Bit 1	Bit 0	
H'FFFC0	SMR	8	C/ \bar{A}	CHR	PE	O/ \bar{E}	STOP	MP	CKS1	CKS0	SCI channel 2
H'FFFC1	BRR	8									
H'FFFC2	SCR	8	TIE	RIE	TE	RE	MPIE	TEIE	CKE1	CKE0	
H'FFFC3	TDR	8									
H'FFFC4	SSR	8	TDRE	RDRF	ORER	FER/ERS	PER	TEND	MPB	MPBT	
H'FFFC5	RDR	8									
H'FFFC6	SCMR	8	—	—	—	—	SDIR	SINV	—	SMIF	
H'FFFC7	Reserved area (access prohibited)										
H'FFFC8	—	—	—	—	—	—	—	—	—	—	
H'FFFC9	—	—	—	—	—	—	—	—	—	—	
H'FFFCA	—	—	—	—	—	—	—	—	—	—	
H'FFFCB	—	—	—	—	—	—	—	—	—	—	
H'FFFC0C	—	—	—	—	—	—	—	—	—	—	
H'FFFC0D	—	—	—	—	—	—	—	—	—	—	
H'FFFC0E	—	—	—	—	—	—	—	—	—	—	
H'FFFC0F	—	—	—	—	—	—	—	—	—	—	
H'FFFD0	Reserved area (access prohibited)										
H'FFFD1											
H'FFFD2											
H'FFFD3	P4DR	8	P4 ₇	P4 ₆	P4 ₅	P4 ₄	P4 ₃	P4 ₂	P4 ₁	P4 ₀	Port4
H'FFFD4	Reserved area (access prohibited)										
H'FFFD5	P6DR	8	P6 ₇	P6 ₆	P6 ₅	P6 ₄	P6 ₃	P6 ₂	P6 ₁	P6 ₀	Port6
H'FFFD6	P7DR	8	P7 ₇	P7 ₆	P7 ₅	P7 ₄	P7 ₃	P7 ₂	P7 ₁	P7 ₀	Port7
H'FFFD7	P8DR	8	—	—	—	P8 ₄	P8 ₃	P8 ₂	P8 ₁	P8 ₀	Port8
H'FFFD8	P9DR	8	—	—	P9 ₅	P9 ₄	P9 ₃	P9 ₂	P9 ₁	P9 ₀	Port9
H'FFFD9	PADR	8	PA ₇	PA ₆	PA ₅	PA ₄	PA ₃	PA ₂	PA ₁	PA ₀	PortA
H'FFFDA	PBDR	8	PB ₇	PB ₆	PB ₅	PB ₄	PB ₃	PB ₂	PB ₁	PB ₀	PortB
H'FFFDB	—	—	—	—	—	—	—	—	—	—	
H'FFFDC	—	—	—	—	—	—	—	—	—	—	
H'FFFDD	—	—	—	—	—	—	—	—	—	—	
H'FFFDE	—	—	—	—	—	—	—	—	—	—	
H'FFPDF	—	—	—	—	—	—	—	—	—	—	

Address (Low)	Register Name	Data Bus Width	Register Name								Module name
			Bit 7	Bit 6	Bit 5	Bit 4	Bit 3	Bit 2	Bit 1	Bit 0	
H'FFFE0	ADDRAH	8	AD9	AD8	AD7	AD6	AD5	AD4	AD3	AD2	A/D converter
H'FFFE1	ADDRAL	8	AD1	AD0	—	—	—	—	—	—	
H'FFFE2	ADDRBH	8	AD9	AD8	AD7	AD6	AD5	AD4	AD3	AD2	
H'FFFE3	ADDRBL	8	AD1	AD0	—	—	—	—	—	—	
H'FFFE4	ADDRCH	8	AD9	AD8	AD7	AD6	AD5	AD4	AD3	AD2	
H'FFFE5	ADDRCL	8	AD1	AD0	—	—	—	—	—	—	
H'FFFE6	ADDRDH	8	AD9	AD8	AD7	AD6	AD5	AD4	AD3	AD2	
H'FFFE7	ADDRDL	8	AD1	AD0	—	—	—	—	—	—	
H'FFFE8	ADCSR	8	ADF	ADIE	ADST	SCAN	CKS	CH2	CH1	CH0	
H'FFFE9	ADCR	8	TRGE	—	—	—	—	—	—	—	

Notes: 1. For write access to TCSR, TCNT, and RSTCSR, see section 12.2.4, Notes on Register Access.

2. The address depends on the output trigger setting.

Legend

WDT: Watchdog timer

TPC: Programmable timing pattern controller

SCI: Serial communication interface

B.2 Functions

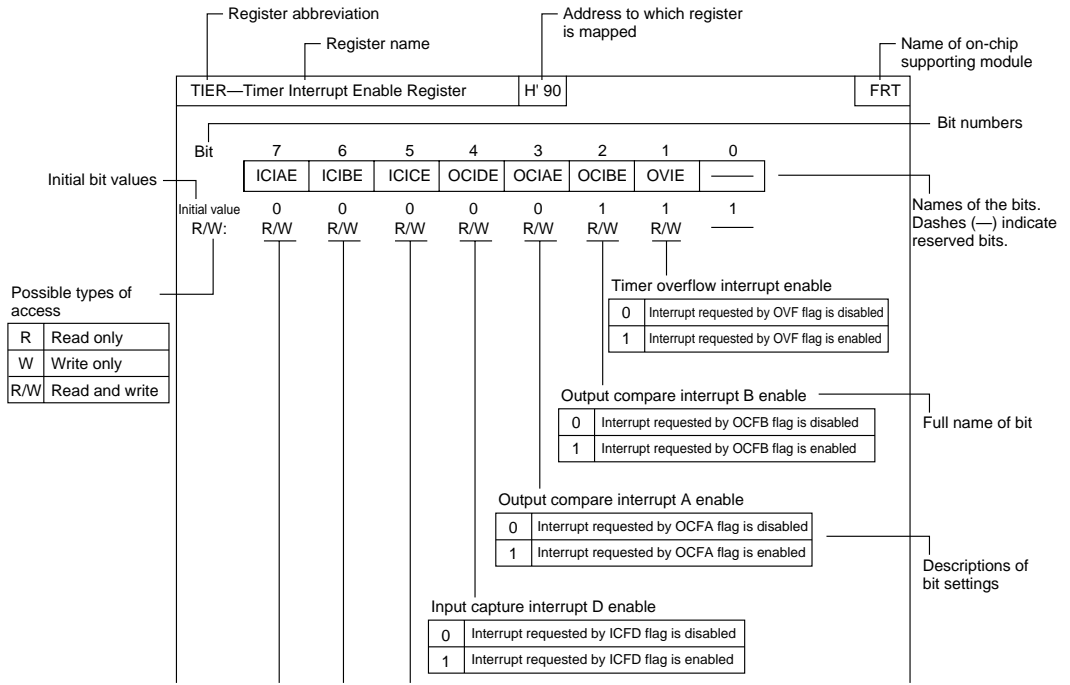

P4DDR—Port 4 Data Direction Register**H'EE003****Port 4**

Bit	7	6	5	4	3	2	1	0
	P47DDR	P46DDR	P45DDR	P44DDR	P43DDR	P42DDR	P41DDR	P40DDR
Initial value	0	0	0	0	0	0	0	0
Read/Write	W	W	W	W	W	W	W	W

Port 4 input/output select

0	Generic input
1	Generic output

P6DDR—Port 6 Data Direction Register**H'EE005****Port 6**

Bit	7	6	5	4	3	2	1	0
	—	P66DDR	P65DDR	P64DDR	P63DDR	P62DDR	P61DDR	P60DDR
Initial value	1	0	0	0	0	0	0	0
Read/Write	—	W	W	W	W	W	W	W

Port 6 input/output select

0	Generic input
1	Generic output

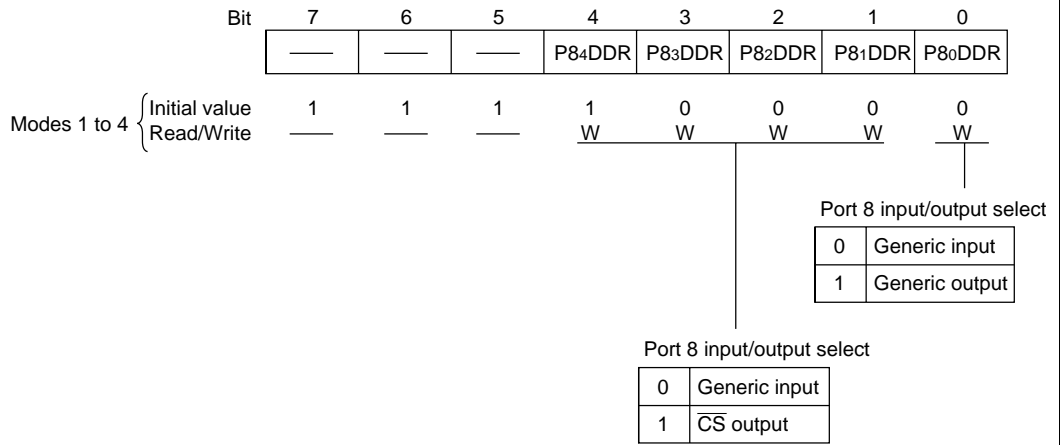

P9DDR—Port 9 Data Direction Register						H'EE008	Port 9					
Bit	7	6	5	4	3	2	1	0				
	—	—	P9 ₅ DDR	P9 ₄ DDR	P9 ₃ DDR	P9 ₂ DDR	P9 ₁ DDR	P9 ₀ DDR				
Initial value	1	1	0	0	0	0	0	0				
Read/Write	—	—	W	W	W	W	W	W				
Port 9 input/output select <table border="1" style="margin: auto; border-collapse: collapse;"> <tr> <td style="text-align: center; width: 20px;">0</td> <td>Generic input</td> </tr> <tr> <td style="text-align: center;">1</td> <td>Generic output</td> </tr> </table>									0	Generic input	1	Generic output
0	Generic input											
1	Generic output											

PADDR—Port A Data Direction Register						H'EE009	Port A					
Bit	7	6	5	4	3	2	1	0				
	PA ₇ DDR	PA ₆ DDR	PA ₅ DDR	PA ₄ DDR	PA ₃ DDR	PA ₂ DDR	PA ₁ DDR	PA ₀ DDR				
Modes 3, 4	1	0	0	0	0	0	0	0				
Read/Write	—	W	W	W	W	W	W	W				
Modes 1, 2	0	0	0	0	0	0	0	0				
Read/Write	W	W	W	W	W	W	W	W				
Port A input/output select <table border="1" style="margin: auto; border-collapse: collapse;"> <tr> <td style="text-align: center; width: 20px;">0</td> <td>Generic input pin</td> </tr> <tr> <td style="text-align: center;">1</td> <td>Generic output pin</td> </tr> </table>									0	Generic input pin	1	Generic output pin
0	Generic input pin											
1	Generic output pin											

PBDDR—Port B Data Direction Register						H'EE00A	Port B					
Bit	7	6	5	4	3	2	1	0				
	PB ₇ DDR	PB ₆ DDR	PB ₅ DDR	PB ₄ DDR	PB ₃ DDR	PB ₂ DDR	PB ₁ DDR	PB ₀ DDR				
Initial value	0	0	0	0	0	0	0	0				
Read/Write	W	W	W	W	W	W	W	W				
Port B input/output select <table border="1" style="margin: auto; border-collapse: collapse;"> <tr> <td style="text-align: center; width: 20px;">0</td> <td>Generic input</td> </tr> <tr> <td style="text-align: center;">1</td> <td>Generic output</td> </tr> </table>									0	Generic input	1	Generic output
0	Generic input											
1	Generic output											

Bit	7	6	5	4	3	2	1	0
	—	—	—	—	—	MDS2	MDS1	MDS0
Initial value	1	1	0	0	0	—*	—*	—*
Read/Write	—	—	—	—	—	R	R	R

Mode select 2 to 0

Bit 2	Bit 1	Bit 0	Operating Mode
MD2	MD1	MD0	
0	0	0	—
		1	Mode 1
	1	0	Mode 2
		1	Mode 3
1	0	0	Mode 4
		1	—
	1	0	—
		1	—

Note: * Determined by the state of the mode pins (MD2 to MD0).

Bit	7	6	5	4	3	2	1	0
	SSBY	STS2	STS1	STS0	UE	NMIEG	SSOE	RAME
Initial value	0	0	0	0	1	0	0	1
Read/Write	R/W	R/W	R/W	R/W	R/W	R/W	R/W	R/W

RAM enable

0	On-chip RAM is disabled
1	On-chip RAM is enabled

Software standby output port enable

0	In software standby mode, all address bus and bus control signals are high-impedance
1	In software standby mode, address bus retains output state and bus control signals are fixed high

NMI edge select

0	An interrupt is requested at the falling edge of NMI
1	An interrupt is requested at the rising edge of NMI

User bit enable

0	CCR bit 6 (UI) is used as an interrupt mask bit
1	CCR bit 6 (UI) is used as a user bit

Standby timer select 2 to 0

Bit 6	Bit 5	Bit 4	Standby Timer
STS2	STS1	STS0	
0	0	0	Waiting Time = 8,192 states
		1	Waiting Time = 16,384 states
	1	0	Waiting Time = 32,768 states
		1	Waiting Time = 65,536 states
1	0	0	Waiting Time = 131,072 states
		1	Waiting Time = 26,2144 states
	1	0	Waiting Time = 1,024 states
		1	Illegal setting

Software standby

0	SLEEP instruction causes transition to sleep mode
1	SLEEP instruction causes transition to software standby mode

BRCR—Bus Release Control Register
H'EE013
Bus controller

Bit	7	6	5	4	3	2	1	0
	A23E	A22E	A21E	A20E	—	—	—	BRLE
Modes 1, 2	1	1	1	1	1	1	1	0
Read/Write	—	—	—	—	—	—	—	R/W
Modes 3, 4	1	1	1	0	1	1	1	0
Read/Write	R/W	R/W	R/W	—	—	—	—	R/W

Address 23 to 20 enable	
0	Address output
1	Other input/output

Bus release enable	
0	The bus cannot be released to an external device
1	The bus can be released to an external device

ISCR—IRQ Sense Control Register
H'EE014
Interrupt Controller

Bit	7	6	5	4	3	2	1	0
	—	—	IRQ5SC	IRQ4SC	IRQ3SC	IRQ2SC	IRQ1SC	IRQ0SC
Initial value	0	0	0	0	0	0	0	0
Read/Write	R/W	R/W	R/W	R/W	R/W	R/W	R/W	R/W

IRQ ₅ to IRQ ₀ sense control	
0	Interrupts are requested when \overline{IRQ}_5 to \overline{IRQ}_0 are low
1	Interrupts are requested by falling-edge input at \overline{IRQ}_5 to \overline{IRQ}_0

Bit	7	6	5	4	3	2	1	0
	—	—	IRQ5E	IRQ4E	IRQ3E	IRQ2E	IRQ1E	IRQ0E
Initial value	0	0	0	0	0	0	0	0
Read/Write	R/W	R/W	R/W	R/W	R/W	R/W	R/W	R/W

IRQ₅ to IRQ₀ enable

0	IRQ ₅ to IRQ ₀ interrupts are disabled
1	IRQ ₅ to IRQ ₀ interrupts are enabled

Bit	7	6	5	4	3	2	1	0
	—	—	IRQ5F	IRQ4F	IRQ3F	IRQ2F	IRQ1F	IRQ0F
Initial value	0	0	0	0	0	0	0	0
Read/Write	—	—	R/(W)*	R/(W)*	R/(W)*	R/(W)*	R/(W)*	R/(W)*

IRQ₅ to IRQ₀ flags

Bits 5 to 0	Setting and Clearing Conditions
IRQ5F to IRQ0F	
0	[Clearing conditions] <ul style="list-style-type: none"> Read IRQ_nF when IRQ_nF = 1, then write 0 in IRQ_nF. IRQ_nSC = 0, $\overline{\text{IRQ}}_n$ input is high, and interrupt exception handling is being carried out. IRQ_nSC = 1 and IRQ_n interrupt exception handling is being carried out.
1	[Setting conditions] <ul style="list-style-type: none"> IRQ_nSC = 0 and $\overline{\text{IRQ}}_n$ input is low. IRQ_nSC = 1 and $\overline{\text{IRQ}}_n$ input changes from high to low.

(n = 5 to 0)

Note: * Only 0 can be written, to clear the flag.

IPRA—Interrupt Priority Register A
H'EE018
Interrupt Controller

Bit	7	6	5	4	3	2	1	0
	IPRA7	IPRA6	IPRA5	IPRA4	IPRA3	IPRA2	IPRA1	IPRA0
Initial value	0	0	0	0	0	0	0	0
Read/Write	R/W	R/W	R/W	R/W	R/W	R/W	R/W	R/W

Priority level A7 to A0

0	Priority level 0 (low priority)
1	Priority level 1 (high priority)

• Interrupt sources controlled by each bit

IPRA	Bit	Bit 7	Bit 6	Bit 5	Bit 4	Bit 3	Bit 2	Bit 1	Bit 0
	Interrupt source	IPRA7	IPRA6	IPRA5	IPRA4	IPRA3	IPRA2	IPRA1	IPRA0
		IRQ0	IRQ1	IRQ2, IRQ3	IRQ4, IRQ5	WDT, DRAM interface, A/D converter	16-bit timer channel 0	16-bit timer channel 1	16-bit timer channel 2

IPRB—Interrupt Priority Register B
H'EE019
Interrupt Controller

Bit	7	6	5	4	3	2	1	0
	IPRB7	IPRB6	IPRB5	——	IPRB3	IPRB2	IPRB1	——
Initial value	0	0	0	0	0	0	0	0
Read/Write	R/W	R/W	R/W	R/W	R/W	R/W	R/W	R/W

Priority level B7 to B5, B3 to B1

0	Priority level 0 (low priority)
1	Priority level 1 (high priority)

• Interrupt sources controlled by each bit

IPRB	Bit	Bit 7	Bit 6	Bit 5	Bit 4	Bit 3	Bit 2	Bit 1	Bit 0
	Interrupt source	IPRB7	IPRB6	IPRB5	——	IPRB3	IPRB2	IPRB1	——
		8-bit timer channels 0 and 1	8-bit timer channels 2 and 3	DMAC	——	SCI channel 0	SCI channel 1	SCI channel 2	——

Bit	7	6	5	4	3	2	1	0
	—	—	—	—	—	—	—	DASTE
Initial value	1	1	1	1	1	1	1	0
Read/Write	—	—	—	—	—	—	—	R/W

D/A standby enable

0	D/A output is disabled in software standby mode (Initial value)
1	D/A output is enabled in software standby mode

Bit	7	6	5	4	3	2	1	0
	—	—	—	—	—	—	DIV1	DIV0
Initial value	1	1	1	1	1	1	0	0
Read/Write	—	—	—	—	—	—	R/W	R/W

Divide 1 and 0

Bit 1	Bit 0	Frequency Division Ratio
DIV1	DIV0	
0	0	1/1 (Initial value)
	1	1/2
1	0	1/4
	1	1/8

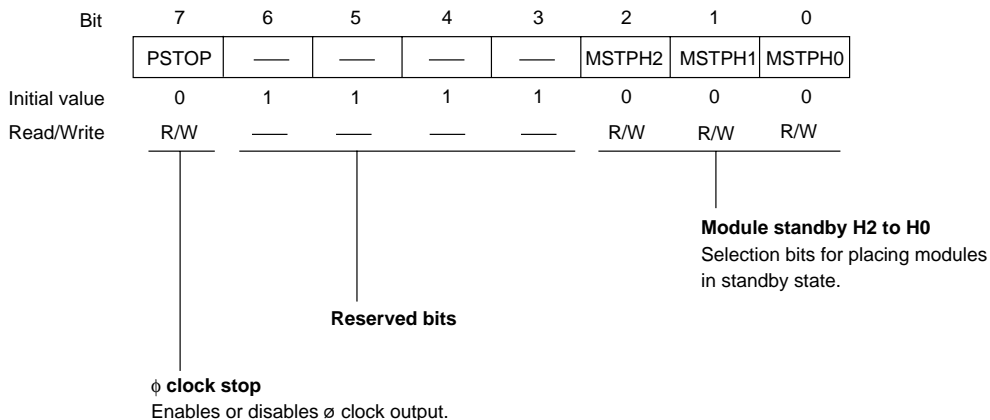
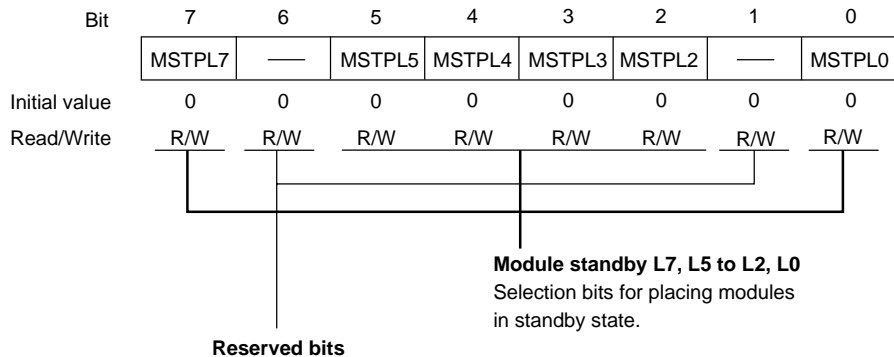
MSTCRH—Module Standby Control Register H
H'EE01C
System control

MSTCRL—Module Standby Control Register L
H'EE01D
System control

Bit	7	6	5	4	3	2	1	0
	CS7E	CS6E	CS5E	CS4E	—	—	—	—
Initial value	0	0	0	0	1	1	1	1
Read/Write	R/W	R/W	R/W	R/W	—	—	—	—

Chip select 7 to 4 enable

Bit n	Description
CSnE	
0	Output of chip select signal CSn is disabled (Initial value)
1	Output of chip select signal CSn is enabled

(n = 7 to 4)

ABWCR—Bus Width Control Register**H'EE020****Bus controller**

Bit	7	6	5	4	3	2	1	0
	ABW7	ABW6	ABW5	ABW4	ABW3	ABW2	ABW1	ABW0
Modes 1, 3	Initial value	1	1	1	1	1	1	1
Modes 2, 4	Initial value	0	0	0	0	0	0	0
	Read/Write	R/W	R/W	R/W	R/W	R/W	R/W	R/W

Area 7 to 0 bus width control

Bits 7 to 0	Bus Width of Access Area
ABW7 to ABW0	
0	Areas 7 to 0 are 16-bit access areas
1	Areas 7 to 0 are 8-bit access areas

ASTCR—Access State Control Register**H'EE021****Bus controller**

Bit	7	6	5	4	3	2	1	0
	AST7	AST6	AST5	AST4	AST3	AST2	AST1	AST0
Initial value	1	1	1	1	1	1	1	1
Read/Write	R/W	R/W	R/W	R/W	R/W	R/W	R/W	R/W

Area 7 to 0 access state control

Bits 7 to 0	Number of States in Access Area
AST7 to AST0	
0	Areas 7 to 0 are two-state access areas
1	Areas 7 to 0 are three-state access areas

Bit	7	6	5	4	3	2	1	0
	W71	W70	W61	W60	W51	W50	W41	W40
Initial value	1	1	1	1	1	1	1	1
Read/Write	R/W	R/W	R/W	R/W	R/W	R/W	R/W	R/W

Area 4 wait control 1 and 0

0	0	No program wait is inserted
	1	1 program wait state is inserted
1	0	2 program wait states are inserted
	1	3 program wait states are inserted

Area 5 wait control 1 and 0

0	0	No program wait is inserted
	1	1 program wait state is inserted
1	0	2 program wait states are inserted
	1	3 program wait states are inserted

Area 6 wait control 1 and 0

0	0	No program wait is inserted
	1	1 program wait state is inserted
1	0	2 program wait states are inserted
	1	3 program wait states are inserted

Area 7 wait control 1 and 0

0	0	No program wait is inserted
	1	1 program wait state is inserted
1	0	2 program wait states are inserted
	1	3 program wait states are inserted

Bit	7	6	5	4	3	2	1	0
	W31	W30	W21	W20	W11	W10	W01	W00
Initial value	1	1	1	1	1	1	1	1
Read/Write	R/W	R/W	R/W	R/W	R/W	R/W	R/W	R/W

Area 0 wait control 1 and 0

0	0	No program wait is inserted
	1	1 program wait state is inserted
1	0	2 program wait states are inserted
	1	3 program wait states are inserted

Area 1 wait control 1 and 0

0	0	No program wait is inserted
	1	1 program wait state is inserted
1	0	2 program wait states are inserted
	1	3 program wait states are inserted

Area 2 wait control 1 and 0

0	0	No program wait is inserted
	1	1 program wait state is inserted
1	0	2 program wait states are inserted
	1	3 program wait states are inserted

Area 3 wait control 1 and 0

0	0	No program wait is inserted
	1	1 program wait state is inserted
1	0	2 program wait states are inserted
	1	3 program wait states are inserted

Bit	7	6	5	4	3	2	1	0
	ICIS1	ICIS0	BROME	BRSTS1	BRSTS0	—	RDEA	WAITE
Initial value	1	1	0	0	0	1	1	0
Read/Write	R/W	R/W	R/W	R/W	R/W	—	R/W	R/W

Wait pin enable	
0	WAIT pin wait input is disabled
1	WAIT pin wait input is enabled

Area division unit select	
0	Area divisions are as follows: Area 0: 2 Mbytes Area 4: 1.93 Mbytes Area 1: 2 Mbytes Area 5: 4 kbytes Area 2: 8 Mbytes Area 6: 23.75 kbytes Area 3: 2 Mbytes Area 7: 22 bytes
1	Areas 0 to 7 are the same size (2 Mbytes)

Burst cycle select 0	
0	Max. 4 words in burst access
1	Max. 8 words in burst access

Burst cycle select 1	
0	Burst access cycle comprises 2 states
1	Burst access cycle comprises 3 states

Burst ROM enable	
0	Area 0 is a basic bus interface area
1	Area 0 is a burst ROM interface area

Idle cycle insertion 0	
0	No idle cycle is inserted in case of consecutive external read and write cycles
1	Idle cycle is inserted in case of consecutive external read and write cycles

Idle cycle insertion 1	
0	No idle cycle is inserted in case of consecutive external read cycles for different areas
1	Idle cycle is inserted in case of consecutive external read cycles for different areas

Bit	7	6	5	4	3	2	1	0
	DRAS2	DRAS1	DRAS0	—	BE	RDM	SRFMD	RFSHE
Initial value	0	0	0	1	0	0	0	0
Read/Write	R/W	R/W	R/W	—	R/W	R/W	R/W	R/W

Refresh pin enable

0	RFSH pin refresh signal output is disabled
1	RFSH pin refresh signal output is enabled

Self-refresh mode

0	DRAM self-refreshing is disabled in software standby mode
1	DRAM self-refreshing is enabled in software standby mode

RAS down mode

0	DRAM interface: RAS up mode selected
1	DRAM interface: RAS down mode selected

Burst access enable

0	Burst disabled (always full access)
1	DRAM space access performed in fast page mode

DRAM area select

DRAS2	DRAS1	DRAS0	Area 5	Area 4	Area 3	Area 2
0	0	0	Normal	Normal	Normal	Normal
		1	Normal	Normal	Normal	DRAM space (\overline{CS}_2)
	1	0	Normal	Normal	DRAM space (\overline{CS}_3)	DRAM space (\overline{CS}_2)
		1	Normal	Normal	DRAM space (\overline{CS}_2)*	
1	0	0	Normal	DRAM space (\overline{CS}_4)	DRAM space (\overline{CS}_3)	DRAM space (\overline{CS}_2)
		1	DRAM space (\overline{CS}_5)	DRAM space (\overline{CS}_4)	DRAM space (\overline{CS}_3)	DRAM space (\overline{CS}_2)
	1	0	DRAM space (\overline{CS}_4)*		DRAM space (\overline{CS}_2)*	
		1	DRAM space (\overline{CS}_2)*			

* A single \overline{CS}_n pin serves as a common \overline{RAS} output pin for a number of areas. Unused \overline{CS}_n pins can be used as input/output ports.

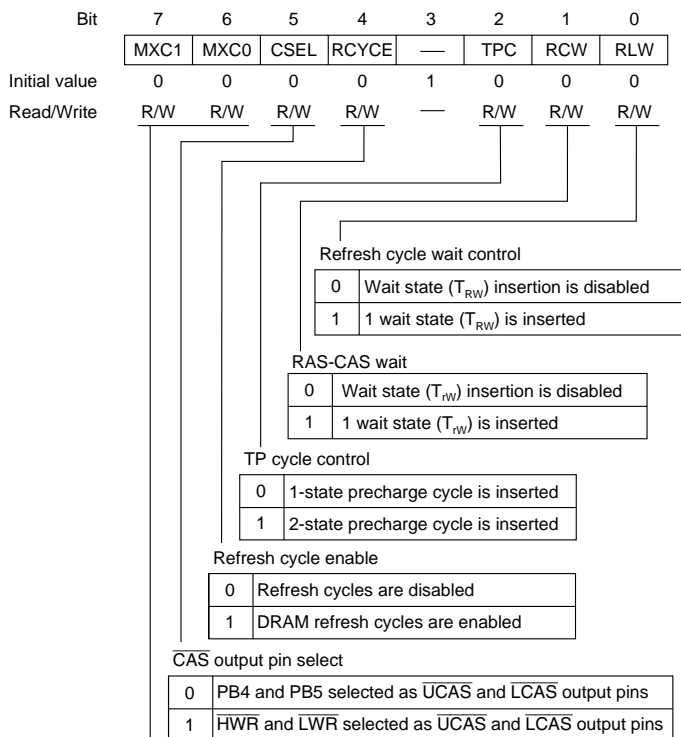

Multiplex control 1 and 0

MXC1	MXC0	Description
0	0	Column address: 8 bits Compared address: Modes 1, 2 8-bit access space A_{19} to A_8 16-bit access space A_{19} to A_9 Modes 3, 4 8-bit access space A_{23} to A_8 16-bit access space A_{23} to A_9
	1	Column address: 9 bits Compared address: Modes 1, 2 8-bit access space A_{19} to A_9 16-bit access space A_{19} to A_{10} Modes 3, 4 8-bit access space A_{23} to A_9 16-bit access space A_{23} to A_{10}
1	0	Column address: 10 bits Compared address: Modes 1, 2 8-bit access space A_{19} to A_{10} 16-bit access space A_{19} to A_{11} Modes 3, 4 8-bit access space A_{23} to A_{10} 16-bit access space A_{23} to A_{11}
	1	Illegal setting

Bit	7	6	5	4	3	2	1	0
	CMF	CMIE	CKS2	CKS1	CKS0	—	—	—
Initial value	0	0	0	0	0	1	1	1
Read/Write	R/(W)*	R/W	R/W	R/W	R/W	—	—	—

Refresh counter clock select

CKS2	CKS1	CKS0	Description
0	0	0	Count operation halted
		1	$\phi/2$ used as counter clock
	1	0	$\phi/8$ used as counter clock
		1	$\phi/32$ used as counter clock
1	0	0	$\phi/128$ used as counter clock
		1	$\phi/512$ used as counter clock
	1	0	$\phi/2048$ used as counter clock
		1	$\phi/4096$ used as counter clock

Compare match interrupt enable

0	The CMI interrupt requested by the CMF flag is disabled
1	The CMI interrupt requested by the CMF flag is enabled

Compare match flag

0	[Clearing conditions] <ul style="list-style-type: none"> • Cleared by a reset and in standby mode • Cleared by reading CMF when CMF = 1, then writing 0 in CMF
1	[Setting condition] When RTCNT = RTCOR

Note: Only 0 can be written to clear the flag.

RTCNT—Refresh Timer Counter**H'EE029****DRAM interface**

Bit	7	6	5	4	3	2	1	0
Initial value	0	0	0	0	0	0	0	0
Read/Write	R/W	R/W	R/W	R/W	R/W	R/W	R/W	R/W

Incremented by internal clock selected
by bits CKS2 to CKS0 in RTMCSR

RTCOR—Refresh Time Constant Register**H'EE02A****DRAM interface**

Bit	7	6	5	4	3	2	1	0
Initial value	1	1	1	1	1	1	1	1
Read/Write	R/W	R/W	R/W	R/W	R/W	R/W	R/W	R/W

RTCNT compare match period

Note: Only byte access should be used with this register.

Bit	7	6	5	4	3	2	1	0
	P47PCR	P46PCR	P45PCR	P44PCR	P43PCR	P42PCR	P41PCR	P40PCR
Initial value	0	0	0	0	0	0	0	0
Read/Write	R/W	R/W	R/W	R/W	R/W	R/W	R/W	R/W

Port 4 input pull-up control 7 to 0

0	Input pull-up transistor is off
1	Input pull-up transistor is on

Note: Valid when the corresponding P4DDR bit is cleared to 0 (designating generic input).

MAR0A R/E/H/L—Memory Address Register 0A R/E/H/L

**H'FFF20 H'FFF21
H'FFF22 H'FFF23**

DMAC0

Bit	31	30	29	28	27	26	25	24	23	22	21	20	19	18	17	16
Initial value	1	1	1	1	1	1	1	1	Undetermined							
Read/Write	—	—	—	—	—	—	—	—	R/W	R/W	R/W	R/W	R/W	R/W	R/W	R/W

MAR0AR

MAR0AE

Bit	15	14	13	12	11	10	9	8	7	6	5	4	3	2	1	0
Initial value	Undetermined								Undetermined							
Read/Write	R/W	R/W	R/W	R/W	R/W	R/W	R/W	R/W	R/W	R/W	R/W	R/W	R/W	R/W	R/W	R/W

MAR0AH

MAR0AL

Source or destination address

- Short address mode

- I/O mode and idle mode

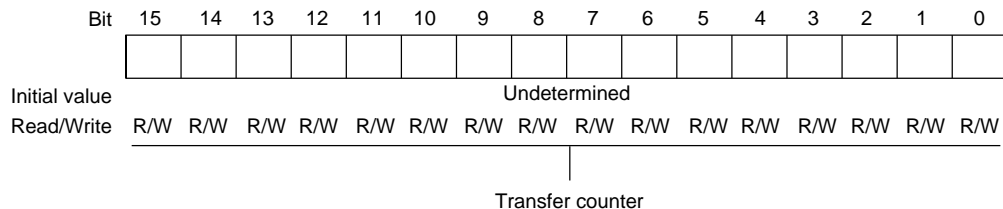

- Repeat mode

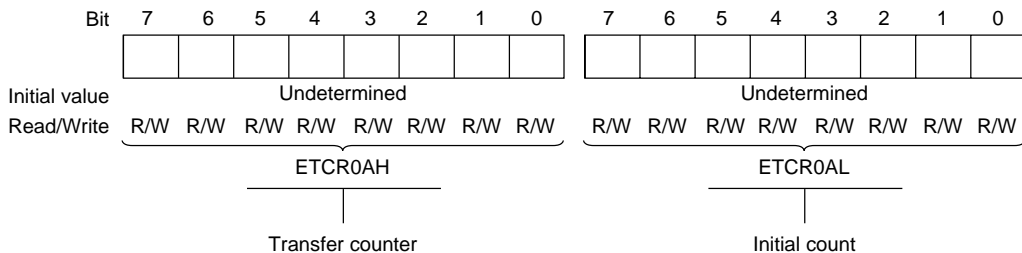

- Full address mode

- Normal mode

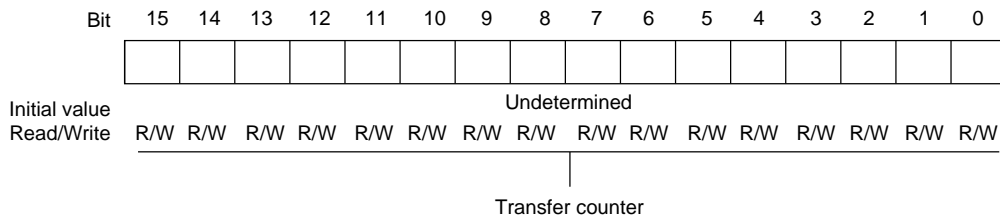

- Block transfer mode

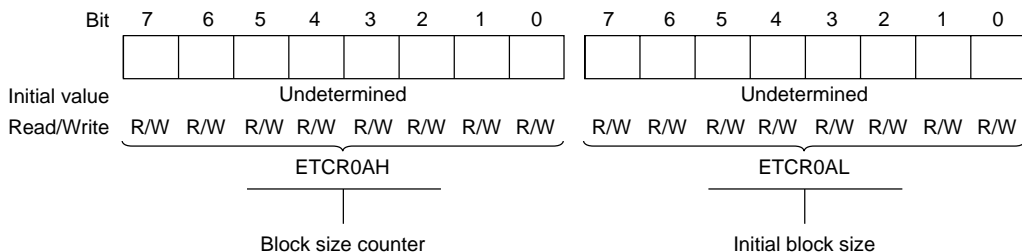

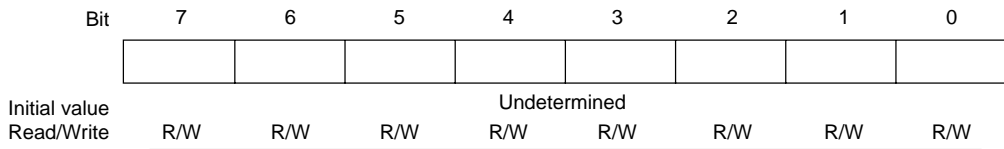

Short address mode : source or destination address

Full address mode : not used

• Short address mode

Bit	7	6	5	4	3	2	1	0
	DTE	DTSZ	DTID	RPE	DTIE	DTS2	DTS1	DTS0
Initial value	0	0	0	0	0	0	0	0
Read/Write	R/W	R/W	R/W	R/W	R/W	R/W	R/W	R/W

Data transfer select

Bit 2 DTS2	Bit 1 DTS1	Bit 0 DTS0	Data Transfer Activation Source
0	0	0	Compare match/input capture A interrupt from 16-bit timer channel 0
		1	Compare match/input capture A interrupt from 16-bit timer channel 1
	1	0	Compare match/input capture A interrupt from 16-bit timer channel 2
		1	A/D converter conversion end interrupt
1	0	0	SCI0 transmit-data-empty interrupt
		1	SCI0 receive-data-full interrupt
	1	0	Transfer in full address mode
		1	Transfer in full address mode

Data transfer interrupt enable

0	Interrupt requested by DTE bit is disabled
1	Interrupt requested by DTE bit is enabled

Repeat enable

RPE	DTIE	Description
0	0	I/O mode
	1	
1	0	Repeat mode
	1	Idle mode

Data transfer increment/decrement

0	Incremented: If DTSZ = 0, MAR is incremented by 1 after each transfer If DTSZ = 1, MAR is incremented by 2 after each transfer
1	Decrement: If DTSZ = 0, MAR is decremented by 1 after each transfer If DTSZ = 1, MAR is decremented by 2 after each transfer

Data transfer size

0	Byte-size transfer
1	Word-size transfer

Data transfer enable

0	Data transfer is disabled
1	Data transfer is enabled

• Full address mode

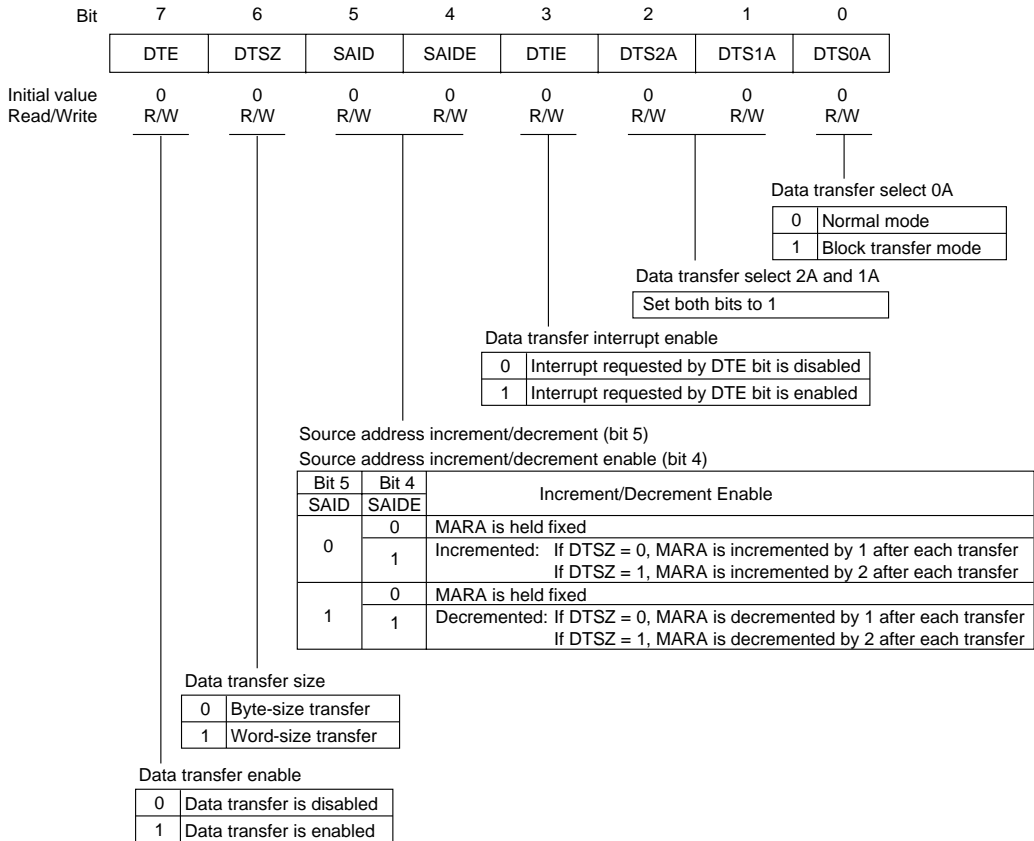

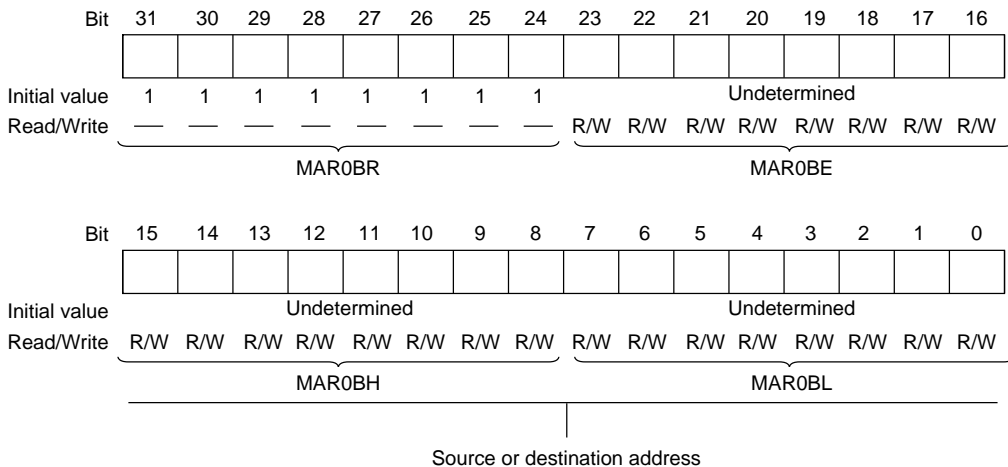

- Short address mode

- I/O mode and idle mode

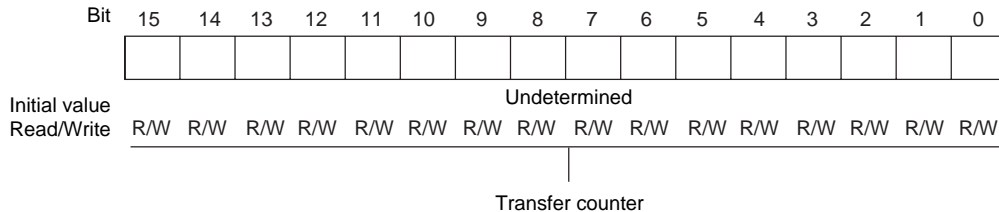

- Repeat mode

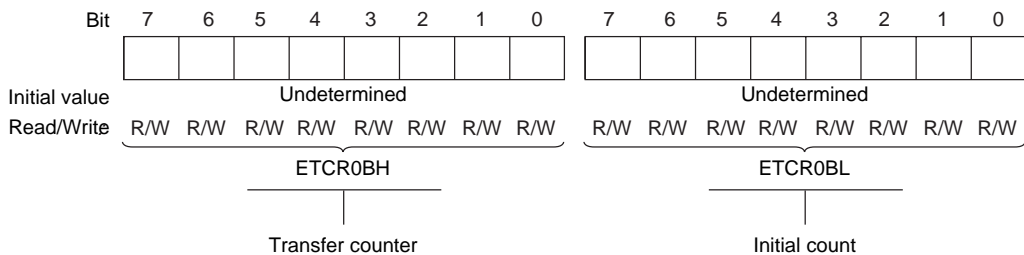

- Full address mode

- Normal mode

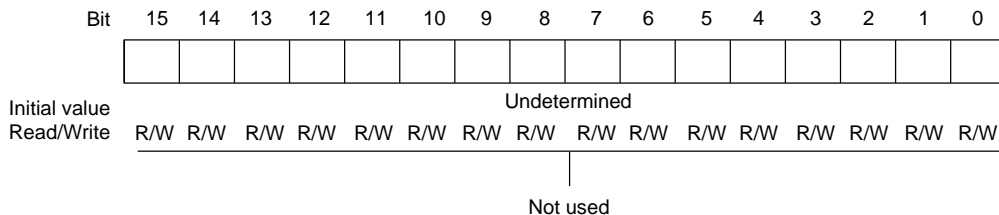

- Block transfer mode

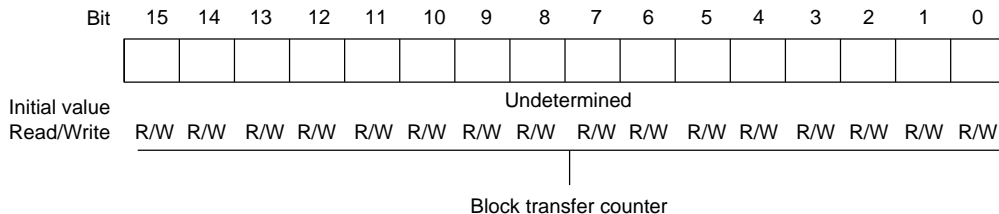

Bit	7	6	5	4	3	2	1	0
Initial value								
Read/Write	R/W	R/W	R/W	R/W	R/W	R/W	R/W	R/W

Undetermined

Short address mode : source or destination address

Full address mode : not used

• Short address mode

Bit	7	6	5	4	3	2	1	0
	DTE	DTSZ	DTID	RPE	DTIE	DTS2	DTS1	DTS0
Initial value	0	0	0	0	0	0	0	0
Read/Write	R/W	R/W	R/W	R/W	R/W	R/W	R/W	R/W

Data transfer select

Bit 2 DTS2	Bit 1 DTS1	Bit 0 DTS0	Data Transfer Activation Source
0	0	0	Compare match/input capture A interrupt from 16-bit timer channel 0
		1	Compare match/input capture A interrupt from 16-bit timer channel 1
	1	0	Compare match/input capture A interrupt from 16-bit timer channel 2
		1	A/D converter conversion end interrupt
1	0	0	SCI0 transmit-data-empty interrupt
		1	SCI0 receive-data-full interrupt
	1	0	Falling edge of DREQ input
		1	Low level of DREQ input

Data transfer interrupt enable

0	Interrupt requested by DTE bit is disabled
1	Interrupt requested by DTE bit is enabled

Repeat enable

RPE	DTIE	Description
0	0	I/O mode
	1	
1	0	Repeat mode
	1	Idle mode

Data transfer increment/decrement

0	Incremented: If DTSZ = 0, MAR is incremented by 1 after each transfer If DTSZ = 1, MAR is incremented by 2 after each transfer
1	Decrement: If DTSZ = 0, MAR is decremented by 1 after each transfer If DTSZ = 1, MAR is decremented by 2 after each transfer

Data transfer size

0	Byte-size transfer
1	Word-size transfer

Data transfer enable

0	Data transfer is disabled
1	Data transfer is enabled

• Full address mode

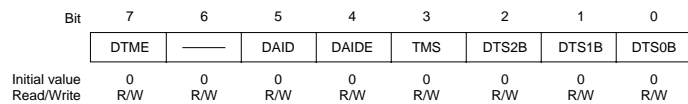

Data transfer master enable

0	Data transfer is disabled
1	Data transfer is enabled

Data transfer select 2B to 0B

Bit 2 DTS2B	Bit 1 DTS1B	Bit 0 DTS0B	Data Transfer Activation Source	
			Normal Mode	Block Transfer Mode
0	0	0	Auto-request (burst mode)	Compare match/input capture A interrupt from 16-bit timer channel 0
		1	Not available	Compare match/input capture A interrupt from 16-bit timer channel 1
	1	0	Auto-request (cycle-steal mode)	Compare match/input capture A interrupt from 16-bit timer channel 2
		1	Not available	A/D converter conversion end interrupt
1	0	0	Not available	Not available
		1	Not available	Not available
	1	0	Falling edge of DREQ input	Falling edge of DREQ input
		1	Low level input at DREQ input	Not available

Transfer mode select

0	Destination is the block area in block transfer mode
1	Source is the block area in block transfer mode

Destination address increment/decrement (bit 5)

Destination address increment/decrement enable (bit 4)

Bit 5 DAID	Bit 4 DAIDE	Increment/Decrement Enable
0	0	MARB is held fixed
	1	Incremented: If DTSZ = 0, MARB is incremented by 1 after each transfer If DTSZ = 1, MARB is incremented by 2 after each transfer
1	0	MARB is held fixed
	1	Decrement: If DTSZ = 0, MARB is decremented by 1 after each transfer If DTSZ = 1, MARB is decremented by 2 after each transfer

MAR1A R/E/H/L—Memory Address Register 1A R/E/H/L

**H'FFF30 H'FFF31
H'FFF32 H'FFF33**

DMAC1

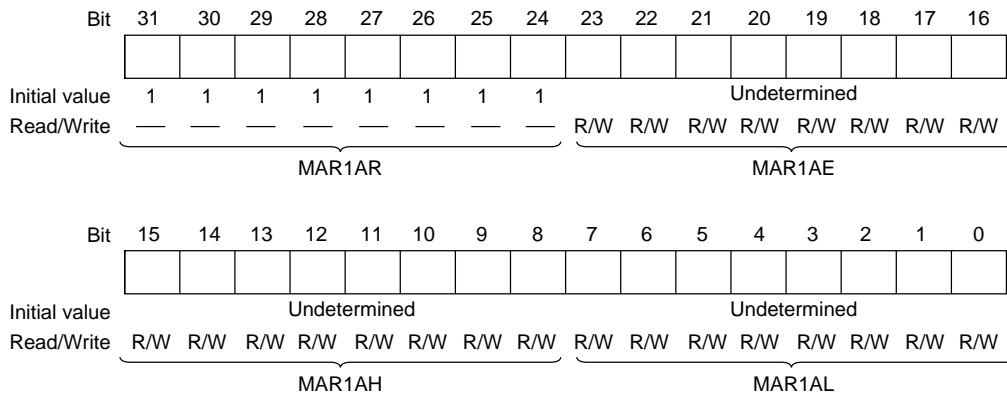

Note: Bit functions are the same as for DMAC0.

ETCR1A H/L—Execute Transfer Count Register 1A H/L

H'FFF34 H'FFF35

DMAC1

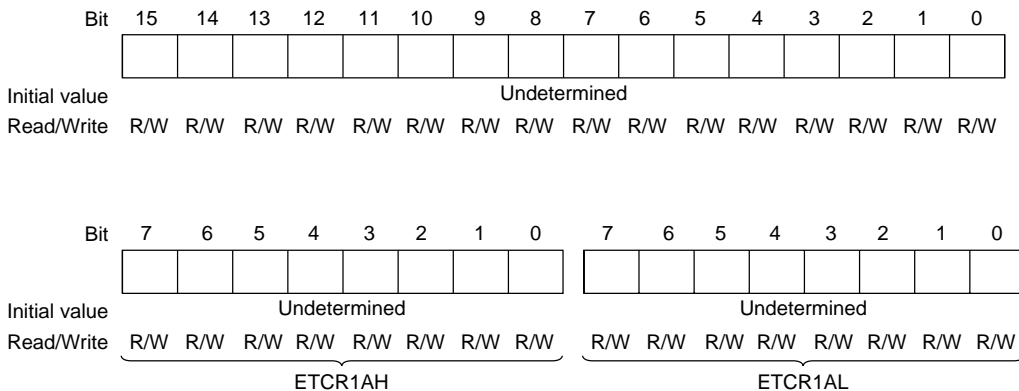

Note: Bit functions are the same as for DMAC0.

IOAR1A—I/O Address Register 1A					H'FFF36		DMAC1	
Bit	7	6	5	4	3	2	1	0
Initial value				Undetermined				
Read/Write	R/W	R/W	R/W	R/W	R/W	R/W	R/W	R/W

Note: Bit functions are the same as for DMAC0.

DTCR1A—Data Transfer Control Register 1A					H'FFF37		DMAC1	
• Short address mode								
Bit	7	6	5	4	3	2	1	0
	DTE	DTSZ	DTID	RPE	DTIE	DTS2	DTS1	DTS0
Initial value	0	0	0	0	0	0	0	0
Read/Write	R/W	R/W	R/W	R/W	R/W	R/W	R/W	R/W
• Full address mode								
Bit	7	6	5	4	3	2	1	0
	DTE	DTSZ	SAID	SAIDE	DTIE	DTS2A	DTS1A	DTS0A
Initial value	0	0	0	0	0	0	0	0
Read/Write	R/W	R/W	R/W	R/W	R/W	R/W	R/W	R/W

Note: Bit functions are the same as for DMAC0.

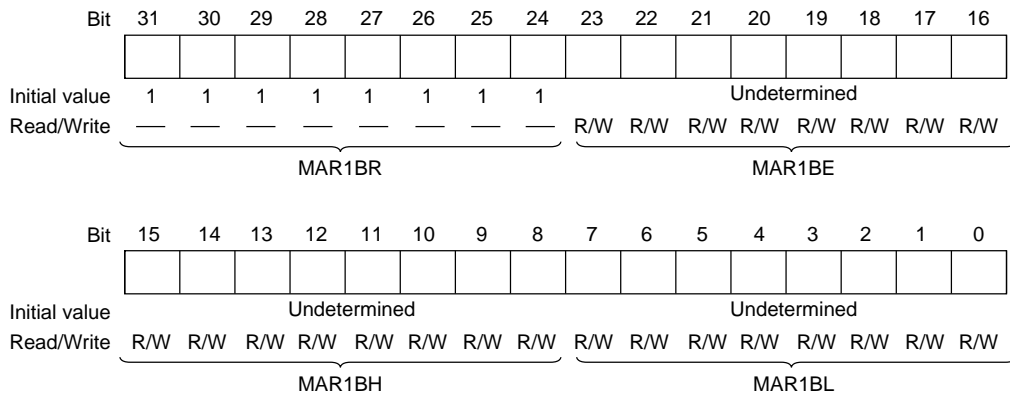
MAR1B R/E/H/L—Memory Address Register 1B R/E/H/L
**H'FFF38 H'FFF39
H'FFF3A H'FFF3B**
DMAC1

Note: Bit functions are the same as for DMAC0.

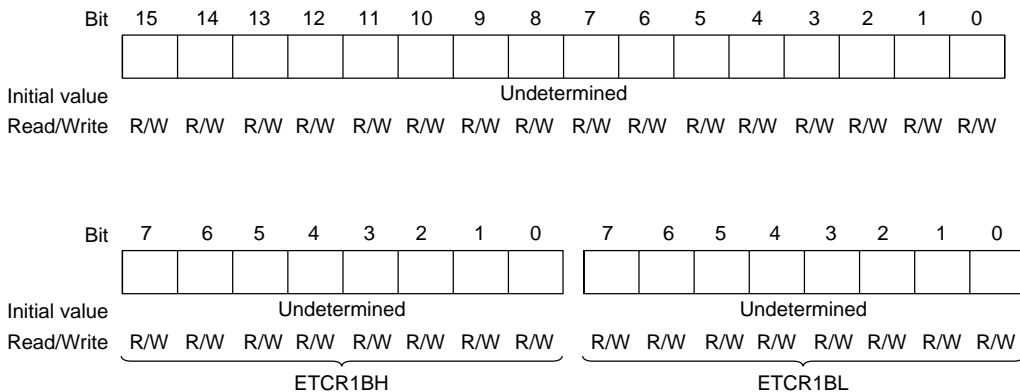
ETCR1B H/L—Execute Transfer Count Register 1B H/L
H'FFF3C H'FFF3D
DMAC1

Note: Bit functions are the same as for DMAC0.

IOAR1B—I/O Address Register 1B					H'FFF3E		DMAC1	
Bit	7	6	5	4	3	2	1	0
Initial value				Undetermined				
Read/Write	R/W	R/W	R/W	R/W	R/W	R/W	R/W	R/W

Note: Bit functions are the same as for DMAC0.

DTCR1B—Data Transfer Control Register 1B					H'FFF3F		DMAC1	
• Short address mode								
Bit	7	6	5	4	3	2	1	0
	DTE	DTSZ	DTID	RPE	DTIE	DTS2	DTS1	DTS0
Initial value	0	0	0	0	0	0	0	0
Read/Write	R/W	R/W	R/W	R/W	R/W	R/W	R/W	R/W
• Full address mode								
Bit	7	6	5	4	3	2	1	0
	DTME	———	DAID	DAIDE	TMS	DTS2B	DTS1B	DTS0B
Initial value	0	0	0	0	0	0	0	0
Read/Write	R/W	R/W	R/W	R/W	R/W	R/W	R/W	R/W

Note: Bit functions are the same as for DMAC0.

TSTR—Timer Start Register

H'FFF60

16-Bit Timer (Common)

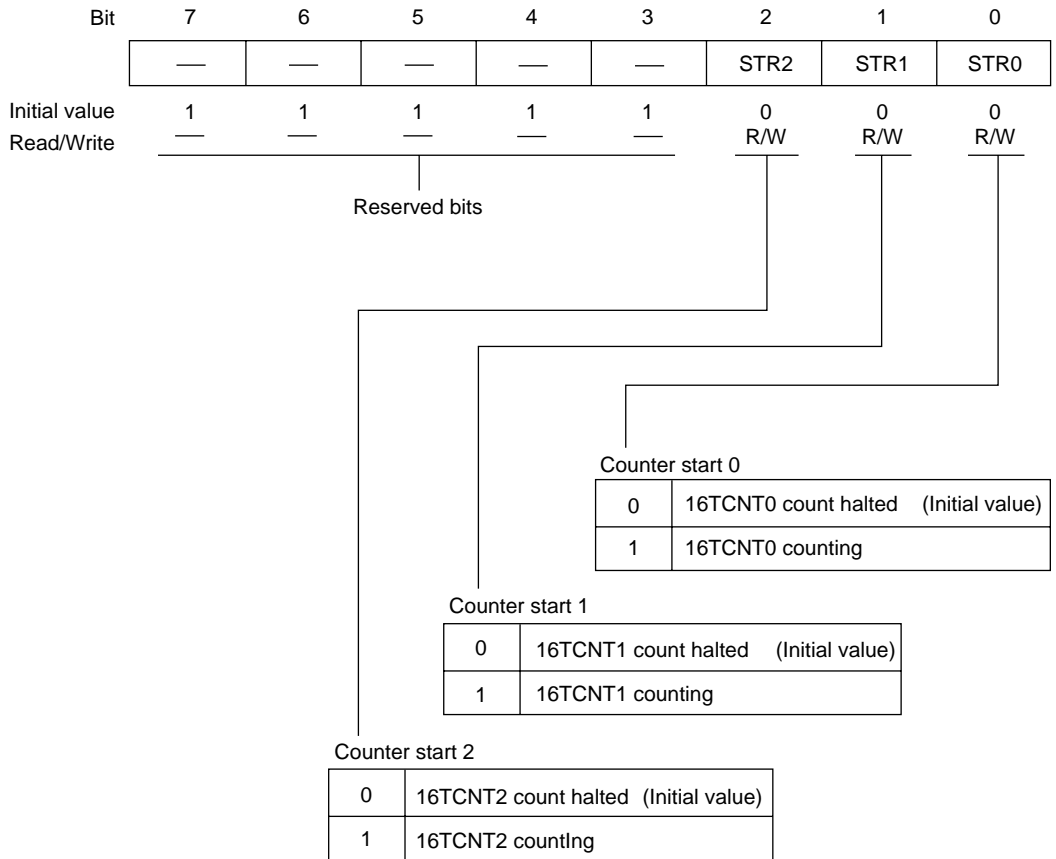

Bit	7	6	5	4	3	2	1	0
	—	—	—	—	—	SYNC2	SYNC1	SYNC0
Initial value	1	1	1	1	1	0	0	0
Read/Write	—	—	—	—	—	R/W	R/W	R/W

Reserved bits

Timer sync 0

0	Channel 0 timer counter (16TCNT0) operates independently (16TCNT0 presetting/clearing unrelated to other channels) (Initial value)
1	Channel 0 operates synchronously 16TCNT0 synchronous presetting/synchronous clearing possible

Timer sync 1

0	Channel 1 timer counter (16TCNT1) operates independently (16TCNT1 presetting/clearing unrelated to other channels) (Initial value)
1	Channel 1 operates synchronously 16TCNT1 synchronous presetting/synchronous clearing possible

Timer sync 2

0	Channel 2 timer counter (16TCNT2) operates independently (16TCNT2 presetting/clearing unrelated to other channels) (Initial value)
1	Channel 2 operates synchronously 16TCNT2 synchronous presetting/synchronous clearing possible

Bit	7	6	5	4	3	2	1	0
	—	MDF	FDIR	—	—	PWM2	PWM1	PWM0
Initial value	1	0	0	1	1	0	0	0
Read/Write	—	R/W	R/W	—	—	R/W	R/W	R/W

PWM mode 0

0	Normal operation selected for channel 0 (Initial value)
1	PWM mode selected for channel 0

PWM mode 1

0	Normal operation selected for channel 1 (Initial value)
1	PWM mode selected for channel 1

PWM mode 2

0	Normal operation selected for channel 2 (Initial value)
1	PWM mode selected for channel 2

Flag direction

0	TISRC OVF flag set to 1 when 16TCNT2 overflows or underflows (Initial value)
1	TISRC OVF flag set to 1 when 16TCNT2 overflows

Phase counting mode

0	Normal operation selected for channel 2 (Initial value)
1	Phase counting mode selected for channel 2

Bit	7	6	5	4	3	2	1	0
	—	—	TOB2	TOA2	TOB1	TOA1	TOB0	TOA0
Initial value	1	1	0	0	0	0	0	0
Read/Write	—	—	W	W	W	W	W	W

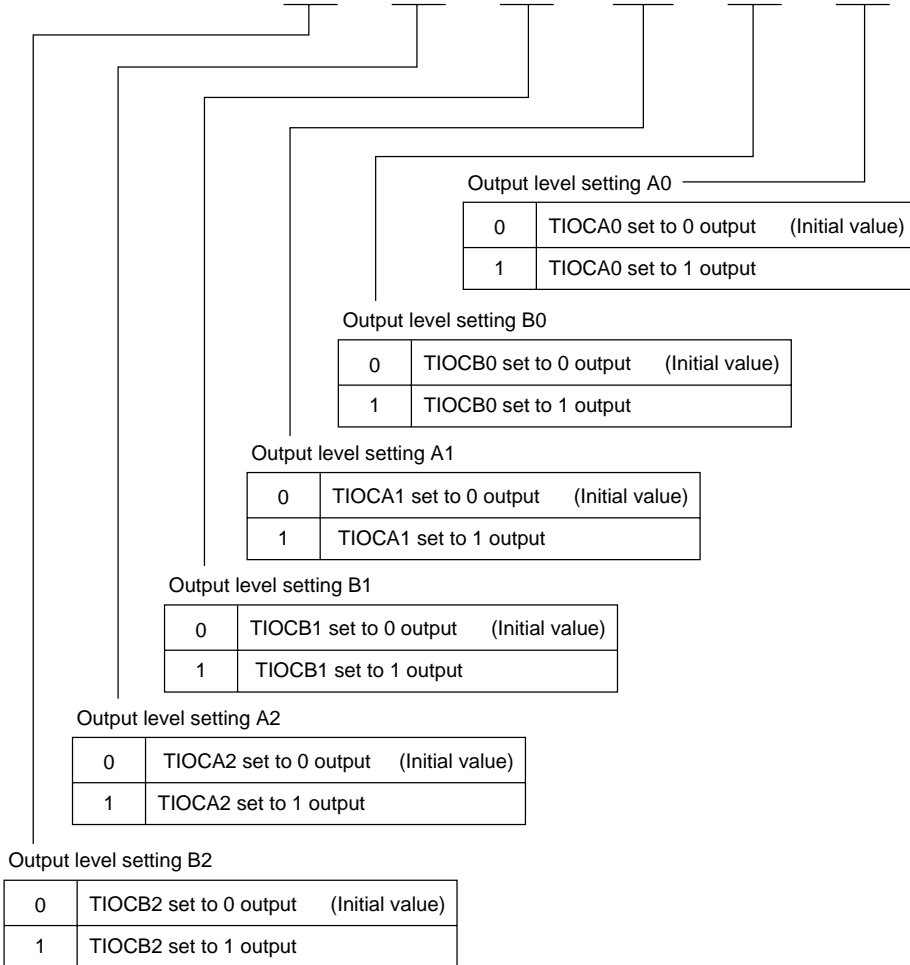

Bit	7	6	5	4	3	2	1	0
	—	IMIEA2	IMIEA1	IMIEA0	—	IMFA2	IMFA1	IMFA0
Initial value	1	0	0	0	1	0	0	0
Read/Write	—	R/W	R/W	R/W	—	R/(W)*	R/(W)*	R/(W)*

Input capture/compare match flag A0

0	[Clearing conditions] (Initial value) • Read IMFA0 when IMFA0 =1, then write 0 in IMFA0 • DMAC activated by IMIA0 interrupt
1	[Setting conditions] • 16TCNT0 = GRA0 when GRA0 functions as an output compare register. • 16TCNT0 value is transferred to GRA0 by an input capture signal when GRA0 functions as an input capture register.

Input capture/compare match flag A1

0	[Clearing conditions] (Initial value) • Read IMFA1 when IMFA1 =1, then write 0 in IMFA1 • DMAC activated by IMIA1 interrupt
1	[Setting conditions] • 16TCNT1 = GRA1 when GRA1 functions as an output compare register • 16TCNT1 value is transferred to GRA1 by an input capture signal when GRA1 functions as an input capture register

Input capture/compare match flag A2

0	[Clearing conditions] (Initial value) • Read IMFA2 when IMFA2 =1, then write 0 in IMFA2 • DMAC activated by IMIA2 interrupt
1	[Setting conditions] • 16TCNT2 = GRA2 when GRA2 functions as an output compare register • 16TCNT2 value is transferred to GRA2 by an input capture signal when GRA2 functions as an input capture register

Input capture/compare match interrupt enable A0

0	IMIA0 interrupt requested by IMFA0 flag is disabled (Initial value)
1	IMIA0 interrupt requested by IMFA0 flag is enabled

Input capture/compare match interrupt enable A1

0	IMIA1 interrupt requested by IMFA1 flag is disabled (Initial value)
1	IMIA1 interrupt requested by IMFA1 flag is enabled

Input capture/compare match interrupt enable A2

0	IMIA2 interrupt requested by IMFA2 flag is disabled (Initial value)
1	IMIA2 interrupt requested by IMFA2 flag is enabled

Note: * Only 0 can be written, to clear the flag.

Bit	7	6	5	4	3	2	1	0
	—	IMIEB2	IMIEB1	IMIEB0	—	IMFB2	IMFB1	IMFB0
Initial value	1	0	0	0	1	0	0	0
Read/Write	—	R/W	R/W	R/W	—	R/(W)*	R/(W)*	R/(W)*

Input capture/compare match flag B0

0	[Clearing condition] (Initial value) Read IMFB0 when IMFB0 =1, then write 0 in IMFB0
1	[Setting conditions] <ul style="list-style-type: none"> 16TCNT0 = GRB0 when GRB0 functions as an output compare register. 16TCNT0 value is transferred to GRB0 by an input capture signal when GRB0 functions as an input capture register.

Input capture/compare match flag B1

0	[Clearing condition] (Initial value) Read IMFB1 when IMFB1 =1, then write 0 in IMFB1
1	[Setting conditions] <ul style="list-style-type: none"> 16TCNT1 = GRB1 when GRB1 functions as an output compare register 16TCNT1 value is transferred to GRB1 by an input capture signal when GRB1 functions as an input capture register

Input capture/compare match flag B2

0	[Clearing condition] (Initial value) Read IMFB2 when IMFB2 =1, then write 0 in IMFB2
1	[Setting conditions] <ul style="list-style-type: none"> 16TCNT2 = GRB2 when GRB2 functions as an output compare register 16TCNT2 value is transferred to GRB2 by an input capture signal when GRB2 functions as an input capture register

Input capture/compare match interrupt enable B0

0	IMIB0 interrupt requested by IMFB0 flag is disabled (Initial value)
1	IMIB0 interrupt requested by IMFB0 flag is enabled

Input capture/compare match interrupt enable B1

0	IMIB1 interrupt requested by IMFB1 flag is disabled (Initial value)
1	IMIB1 interrupt requested by IMFB1 flag is enabled

Input capture/compare match interrupt enable B2

0	IMIB2 interrupt requested by IMFB2 flag is disabled (Initial value)
1	IMIB2 interrupt requested by IMFB2 flag is enabled

Note: * Only 0 can be written, to clear the flag.

Bit	7	6	5	4	3	2	1	0
	—	OVIE2	OVIE1	OVIE0	—	OVF2	OVF1	OVF0
Initial value	1	0	0	0	1	0	0	0
Read/Write	—	R/W	R/W	R/W	—	R/(W)*	R/(W)*	R/(W)*

Overflow flag 0

0	[Clearing condition] Read OVF0 when OVF0 =1, then write 0 in OVF0	(Initial value)
1	[Setting condition] 16TCNT0 overflowed from H'FFFF to H'0000	

Overflow flag 1

0	[Clearing condition] Read OVF1 when OVF1 =1, then write 0 in OVF1	(Initial value)
1	[Setting condition] 16TCNT1 overflowed from H'FFFF to H'0000	

Overflow flag 2

0	[Clearing condition] Read OVF2 when OVF2 =1, then write 0 in OVF2	(Initial value)
1	[Setting condition] 16TCNT2 overflowed from H'FFFF to H'0000 or underflowed from H'0000 to H'FFFF	

Overflow interrupt enable 0

0	OVI0 interrupt requested by OVF0 flag is disabled	(Initial value)
1	OVI0 interrupt requested by OVF0 flag is enabled	

Overflow interrupt enable 1

0	OVI1 interrupt requested by OVF1 flag is disabled	(Initial value)
1	OVI1 interrupt requested by OVF1 flag is enabled	

Overflow interrupt enable 2

0	OVI2 interrupt requested by OVF2 flag is disabled	(Initial value)
1	OVI2 interrupt requested by OVF2 flag is enabled	

Note: * Only 0 can be written, to clear the flag.

Bit	7	6	5	4	3	2	1	0
	—	CCLR1	CCLR0	CKEG1	CKEG0	TPSC2	TPSC1	TPSC0
Initial value	1	0	0	0	0	0	0	0
Read/Write	—	R/W	R/W	R/W	R/W	R/W	R/W	R/W

Timer prescaler 2 to 0

Bit 2	Bit 1	Bit 0	Description
TPSC2	TPSC1	TPSC0	
0	0	0	Internal clock: Counts on ϕ (Initial value)
		1	Internal clock: Counts on $\phi/2$
	1	0	Internal clock: Counts on $\phi/4$
		1	Internal clock: Counts on $\phi/8$
1	0	0	External clock A: Counts on TCLKA pin input
		1	External clock B: Counts on TCLKB pin input
	1	0	External clock C: Counts on TCLKC pin input
		1	External clock D: Counts on TCLKD pin input

Clock edge 1 and 0

Bit 4	Bit 3	Description
CKEG1	CKEG0	
0	0	Counts on rising edge (Initial value)
0	1	Counts on falling edge
1	—	Counts on both rising and falling edges

Counter clear 1 and 0

Bit 6	Bit 5	Description
CCLR1	CCLR0	
0	0	16TCNT clearing disabled (Initial value)
	1	16TCNT cleared by GRA compare match/input capture
1	0	16TCNT cleared by GRB compare match/input capture
	1	Synchronous clear. 16TCNT cleared in synchronization with counter clearing of other timers operating synchronously.

Bit	7	6	5	4	3	2	1	0
	—	IOB2	IOB1	IOB0	—	IOA2	IOA1	IOA0
Initial value	1	0	0	0	1	0	0	0
Read/Write	—	R/W	R/W	R/W	—	R/W	R/W	R/W

I/O control A2 to A0

Bit 2	Bit 1	Bit 0	Description	
IOA2	IOA1	IOA0		
0	0	0	GRA is output compare register	Pin output at compare match disabled (Initial value)
		1		0 output at GRA compare match
	1	0		1 output at GRA compare match
		1		Toggle output at GRA compare match (1 output on channel 2 only)
1	0	0	GRA is input capture register	Input capture in GRA at rising edge
		1		Input capture in GRA at falling edge
	1	0		Input capture at both rising and falling edges
		1		

I/O control B2 to B0

Bit 6	Bit 5	Bit 4	Description	
IOB2	IOB1	IOB0		
0	0	0	GRB is output compare register	Pin output at compare match disabled (Initial value)
		1		0 output at GRB compare match
	1	0		1 output at GRB compare match
		1		Toggle output at GRB compare match (1 output on channel 2 only)
1	0	0	GRB is input capture register	Input capture in GRB at rising edge
		1		Input capture in GRB at falling edge
	1	0		Input capture at both rising and falling edges
		1		

16TCNT0H/L—Timer Counter 0H/L**H'FFF6A
H'FFF6B****16-Bit Timer Channel 0**

Bit	15	14	13	12	11	10	9	8	7	6	5	4	3	2	1	0
Initial value	0	0	0	0	0	0	0	0	0	0	0	0	0	0	0	0
Read/Write	R/W	R/W	R/W	R/W	R/W	R/W	R/W	R/W	R/W	R/W	R/W	R/W	R/W	R/W	R/W	R/W

|
Up-counter

GRA0H/L—General Register A0 H/L**H'FFF6C
H'FFF6D****16-Bit Timer Channel 0**

Bit	15	14	13	12	11	10	9	8	7	6	5	4	3	2	1	0
Initial value	1	1	1	1	1	1	1	1	1	1	1	1	1	1	1	1
Read/Write	R/W	R/W	R/W	R/W	R/W	R/W	R/W	R/W	R/W	R/W	R/W	R/W	R/W	R/W	R/W	R/W

|
Output compare/input capture dual-function register

GRB0H/L—General Register B0 H/L**H'FFF6E
H'FFF6F****16-Bit Timer Channel 0**

Bit	15	14	13	12	11	10	9	8	7	6	5	4	3	2	1	0
Initial value	1	1	1	1	1	1	1	1	1	1	1	1	1	1	1	1
Read/Write	R/W	R/W	R/W	R/W	R/W	R/W	R/W	R/W	R/W	R/W	R/W	R/W	R/W	R/W	R/W	R/W

|
Output compare/input capture dual-function register

16TCR1—Timer Control Register 1				H'FFF70		16-Bit Timer Channel 1		
Bit	7	6	5	4	3	2	1	0
	——	CCLR1	CCLR0	CKEG1	CKEG0	TPSC2	TPSC1	TPSC0
Initial value	1	0	0	0	0	0	0	0
Read/Write	——	R/W	R/W	R/W	R/W	R/W	R/W	R/W

* Bit functions are the same as for 16-bit timer channel 0.

TIOR1—Timer I/O Control Register 1				H'FFF71		16-Bit Timer Channel 1		
Bit	7	6	5	4	3	2	1	0
	——	IOB2	IOB1	IOB0	——	IOA2	IOA1	IOA0
Initial value	1	0	0	0	1	0	0	0
Read/Write	——	R/W	R/W	R/W	——	R/W	R/W	R/W

* Bit functions are the same as for 16-bit timer channel 0.

16TCNT1H/L—Timer Counter 1H/L								H'FFF72 H'FFF73		16-Bit Timer Channel 1						
Bit	15	14	13	12	11	10	9	8	7	6	5	4	3	2	1	0
Initial value	0	0	0	0	0	0	0	0	0	0	0	0	0	0	0	0
Read/Write	R/W	R/W	R/W	R/W	R/W	R/W	R/W	R/W	R/W	R/W	R/W	R/W	R/W	R/W	R/W	R/W

* Bit functions are the same as for 16-bit timer channel 0.

GRA1H/L—General Register A1 H/L**H'FFF74
H'FFF75****16-Bit Timer Channel 1**

Bit	15	14	13	12	11	10	9	8	7	6	5	4	3	2	1	0
-----	----	----	----	----	----	----	---	---	---	---	---	---	---	---	---	---

--	--	--	--	--	--	--	--	--	--	--	--	--	--	--	--	--

Initial value	1	1	1	1	1	1	1	1	1	1	1	1	1	1	1	1
---------------	---	---	---	---	---	---	---	---	---	---	---	---	---	---	---	---

Read/Write	R/W	R/W	R/W	R/W	R/W	R/W	R/W	R/W	R/W	R/W	R/W	R/W	R/W	R/W	R/W	R/W
------------	-----	-----	-----	-----	-----	-----	-----	-----	-----	-----	-----	-----	-----	-----	-----	-----

* Bit functions are the same as for 16-bit timer channel 0.

GRB1H/L—General Register B1 H/L**H'FFF76
H'FFF77****16-Bit Timer Channel 1**

Bit	15	14	13	12	11	10	9	8	7	6	5	4	3	2	1	0
-----	----	----	----	----	----	----	---	---	---	---	---	---	---	---	---	---

--	--	--	--	--	--	--	--	--	--	--	--	--	--	--	--	--

Initial value	1	1	1	1	1	1	1	1	1	1	1	1	1	1	1	1
---------------	---	---	---	---	---	---	---	---	---	---	---	---	---	---	---	---

Read/Write	R/W	R/W	R/W	R/W	R/W	R/W	R/W	R/W	R/W	R/W	R/W	R/W	R/W	R/W	R/W	R/W
------------	-----	-----	-----	-----	-----	-----	-----	-----	-----	-----	-----	-----	-----	-----	-----	-----

* Bit functions are the same as for 16-bit timer channel 0.

16TCR2—Timer Control Register 2**H'FFF78****16-Bit Timer Channel 2**

Bit	7	6	5	4	3	2	1	0
-----	---	---	---	---	---	---	---	---

	———	CCLR1	CCLR0	CKEG1	CKEG0	TPSC2	TPSC1	TPSC0
--	-----	-------	-------	-------	-------	-------	-------	-------

Initial value	1	0	0	0	0	0	0	0
---------------	---	---	---	---	---	---	---	---

Read/Write	———	R/W	R/W	R/W	R/W	R/W	R/W	R/W
------------	-----	-----	-----	-----	-----	-----	-----	-----

* Bit functions are the same as for 16-bit timer channel 0.

Note: The settings of bits CKEG1 and CKEG0 and bits TPSC2 to TPSC0 in 16TCR2 are invalid when phase counting mode is selected for channel 2.

TIOR2—Timer I/O Control Register 2				H'FFF79		16-Bit Timer Channel 2		
Bit	7	6	5	4	3	2	1	0
	——	IOB2	IOB1	IOB0	——	IOA2	IOA1	IOA0
Initial value	1	0	0	0	1	0	0	0
Read/Write	——	R/W	R/W	R/W	——	R/W	R/W	R/W

* Bit functions are the same as for 16-bit timer channel 0.

16TCNT2H/L—Timer Counter 2H/L								H'FFF7A H'FFF7B		16-Bit Timer Channel 2						
Bit	15	14	13	12	11	10	9	8	7	6	5	4	3	2	1	0
Initial value	0	0	0	0	0	0	0	0	0	0	0	0	0	0	0	0
Read/Write	R/W	R/W	R/W	R/W	R/W	R/W	R/W	R/W	R/W	R/W	R/W	R/W	R/W	R/W	R/W	R/W

Phase counting mode: Up/down-counter
Other modes: Up-counter

GRA2H/L—General Register A2 H/L								H'FFF7C H'FFF7D		16-Bit Timer Channel 2						
Bit	15	14	13	12	11	10	9	8	7	6	5	4	3	2	1	0
Initial value	1	1	1	1	1	1	1	1	1	1	1	1	1	1	1	1
Read/Write	R/W	R/W	R/W	R/W	R/W	R/W	R/W	R/W	R/W	R/W	R/W	R/W	R/W	R/W	R/W	R/W

* Bit functions are the same as for 16-bit timer channel 0.

Bit	15	14	13	12	11	10	9	8	7	6	5	4	3	2	1	0
Initial value	1	1	1	1	1	1	1	1	1	1	1	1	1	1	1	1
Read/Write	R/W	R/W	R/W	R/W	R/W	R/W	R/W	R/W	R/W	R/W	R/W	R/W	R/W	R/W	R/W	R/W

* Bit functions are the same as for 16-bit timer channel 0.

8TCR0—Timer Control Register 0
8TCR1—Timer Control Register 1

H'FFF80
H'FFF81

8-bit timer channel 0
8-bit timer channel 1

Bit	7	6	5	4	3	2	1	0
	CMIEB	CMIEA	OVIE	CCLR1	CCLR0	CKS2	CKS1	CKS0
Initial value	0	0	0	0	0	0	0	0
Read/Write	R/W	R/W	R/W	R/W	R/W	R/W	R/W	R/W

0	0	0	Clock input is disabled
		1	Internal clock, counted on rising edge of $\phi/8$
	1	0	Internal clock, counted on rising edge of $\phi/64$
		1	Internal clock, counted on rising edge of $\phi/8192$
1	0	0	Channel 0: Count on 8TCNT1 overflow signal* Channel 1: Count on 8TCNT0 compare match A*
		1	External clock, counted on falling edge
	1	0	External clock, counted on rising edge
		1	External clock, counted on both rising and falling edges

Note: * If the clock input of channel 0 is the 8TCNT1 overflow signal and that of channel 1 is the 8TCNT0 compare match signal, no incrementing clock is generated. Do not use

0	0	Clearing is disabled
	1	Cleared by compare match A
1	0	Cleared by compare match B/input capture B
	1	Cleared by input capture B

0	OVI interrupt requested by OVF is disabled
1	OVI interrupt requested by OVF is enabled

0	CMIA interrupt requested by CMFA is disabled
1	CMIA interrupt requested by CMFA is enabled

0	CMIB interrupt requested by CMFB is disabled
1	CMIB interrupt requested by CMFB is enabled

Bit	7	6	5	4	3	2	1	0
	CMFB	CMFA	OVF	ADTE	OIS3	OIS2	OS1	OS0
Initial value	0	0	0	0	0	0	0	0
Read/Write	R/(W)*	R/(W)*	R/(W)*	R/W	R/W	R/W	R/W	R/W

Output select A1 and A0

	Bit 1	Bit 0	Description
	OS1	OS0	
0	0	0	No change at compare match A
	1	1	0 output at compare match A
1	0	0	1 output at compare match A
	1	1	Output toggles at compare match A

Output/input capture edge select B3 and B2

ICE in 8TCSR1	Bit 3	Bit 2	Description
	OIS3	OIS2	
0	0	0	No change at compare match B
		1	0 output at compare match B
	1	0	1 output at compare match B
		1	Output toggles at compare match B
1	0	0	TCORB input capture on rising edge
		1	TCORB input capture on falling edge
	1	0	TCORB input capture on both rising and falling edges
		1	1

A/D trigger enable

TRGE*	Bit 4 ADTE	Description
0	0	A/D converter start requests by compare match A or an external trigger are disabled
	1	A/D converter start requests by compare match A or an external trigger are enabled
1	0	A/D converter start requests by an external trigger are enabled, and A/D converter start requests by compare match A are disabled
	1	A/D converter start requests by compare match A are enabled, and A/D converter start requests by an external trigger are disabled

Note: * TRGE is bit 7 of the A/D control register (ADCR).

Timer overflow flag

0	[Clearing condition] Read OVF when OVF = 1, then write 0 in OVF.
1	[Setting condition] 8TCNT overflows from H'FF to H'00.

Compare match flag A

0	[Clearing condition] Read CMFA when CMFA = 1, then write 0 in CMFA.
1	[Setting condition] 8TCNT = TCORA

Compare match/input capture flag B

0	[Clearing condition] Read CMFB when CMFB = 1, then write 0 in CMFB.
1	[Setting conditions] • 8TCNT = TCORB • The 8TCNT value is transferred to TCORB by an input capture signal when TCORB functions as an input capture register.

Note: * Only 0 can be written to bits 7 to 5, to clear these flags.

Bit	7	6	5	4	3	2	1	0
	CMFB	CMFA	OVF	ICE	OIS3	OIS2	OS1	OS0
Initial value	0	0	0	0	0	0	0	0
Read/Write	R/(W)*	R/(W)*	R/(W)*	R/W	R/W	R/W	R/W	R/W

Bit 1	Bit 0	Description
0	0	No change at compare match A
	1	0 output at compare match A
1	0	1 output at compare match A
	1	Output toggles at compare match A

ICE in 8TCSR1	Bit 3	Bit 2	Description
	OIS3	OIS2	
0	0	0	No change at compare match B
		1	0 output at compare match B
	1	0	1 output at compare match B
		1	Output toggles at compare match B
1	0	0	TCORB input capture on rising edge
		1	TCORB input capture on falling edge
	1	0	TCORB input capture on both rising and falling edges
		1	TCORB input capture on both rising and falling edges

0	TCORB is a compare match register
1	TCORB is an input capture register

0	[Clearing condition] Read OVF when OVF = 1, then write 0 in OVF.
1	[Setting condition] 8TCNT overflows from H'FF to H'00.

0	[Clearing condition] Read CMFA when CMFA = 1, then write 0 in CMFA.
1	[Setting condition] 8TCNT = TCORA

0	[Clearing condition] Read CMFB when CMFB = 1, then write 0 in CMFB.
1	[Setting conditions] <ul style="list-style-type: none"> 8TCNT = TCORB The 8TCNT value is transferred to TCORB by an input capture signal when TCORB functions as an input capture register.

Note: * Only 0 can be written to bits 7 to 5, to clear these flags.

TCORA0—Timer Constant Register A0
TCORA1—Timer Constant Register A1

H'FFF84
H'FFF85

8-bit timer channel 0
8-bit timer channel 1

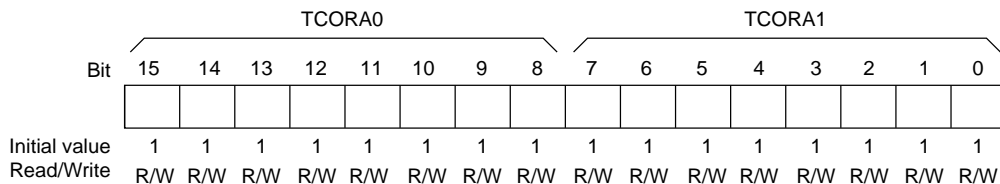

TCORB0—Timer Constant Register B0
TCORB1—Timer Constant Register B1

H'FFF86
H'FFF87

8-bit timer channel 0
8-bit timer channel 1

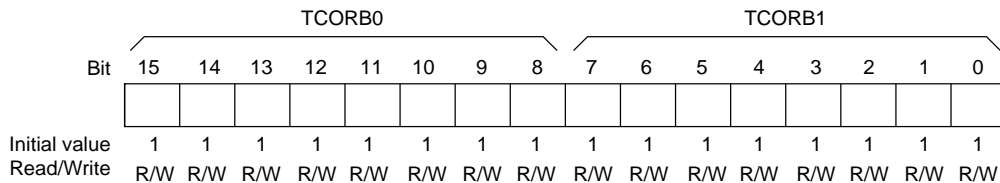

8TCNT0—Timer Counter 0
8TCNT1—Timer Counter 1

H'FFF88
H'FFF89

8-bit timer channel 0
8-bit timer channel 1

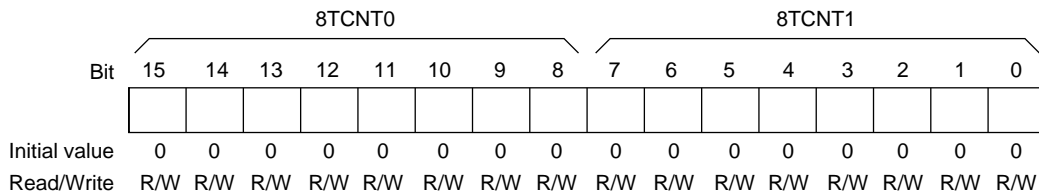

Bit	7	6	5	4	3	2	1	0
	OVF	WT/ \bar{T}	TME	—	—	CKS2	CKS1	CKS0
Initial value	0	0	0	1	1	0	0	0
Read/Write	R/(W)*	R/W	R/W	—	—	R/W	R/W	R/W

Clock select 2 to 0

CKS2	CKS1	CKS0	Description
0	0	0	$\phi/2$
		1	$\phi/32$
	1	0	$\phi/64$
		1	$\phi/128$
1	0	0	$\phi/256$
		1	$\phi/512$
	1	0	$\phi/2048$
		1	$\phi/4096$

Timer enable

0	Timer disabled • TCNT is initialized to H'00 and halted
1	Timer enabled • TCNT is counting

Timer mode select

0	Interval timer: requests interval timer interrupts
1	Watchdog timer: generates a reset signal

Overflow flag

0	[Clearing condition] Read OVF when OVF = 1, then write 0 in OVF
1	[Setting condition] TCNT changes from H'FF to H'00

Note: * Only 0 can be written, to clear the flag.

TCNT—Timer Counter
H'FFF8D (read), H'FFF8C (write)
WDT

Bit	7	6	5	4	3	2	1	0
Initial value	0	0	0	0	0	0	0	0
Read/Write	R/W	R/W	R/W	R/W	R/W	R/W	R/W	R/W

Count value

RSTCSR—Reset Control/Status Register
H'FFF8F (read), H'FFF8E (write)
WDT

Bit	7	6	5	4	3	2	1	0
Initial value	0	0	1	1	1	1	1	1
Read/Write	R/(W)*	R/W	—	—	—	—	—	—

Reset output enable

0	External output of reset signal is disabled
1	External output of reset signal is enabled

Watchdog timer reset

0	[Clearing conditions] <ul style="list-style-type: none"> Reset signal at $\overline{\text{RES}}$ pin Read WRST when WRST = 1, then write 0 in WRST
1	[Setting condition] TCNT overflow generates a reset signal

Note: * Only 0 can be written in bit 7, to clear the flag.

8TCR2—Timer Control Register 2
8TCR3—Timer Control Register 3

H'FFF90
H'FFF91

8-bit timer channel 2
8-bit timer channel 3

Bit	7	6	5	4	3	2	1	0
	CMIEB	CMIEA	OVIE	CCLR1	CCLR0	CKS2	CKS1	CKS0
Initial value	0	0	0	0	0	0	0	0
Read/Write	R/W	R/W	R/W	R/W	R/W	R/W	R/W	R/W

Clock select 2 to 0

CKS2	CKS1	CKS0	Description
0	0	0	Clock input is disabled
		1	Internal clock, counted on rising edge of $\phi/8$
	1	0	Internal clock, counted on rising edge of $\phi/64$
		1	Internal clock, counted on rising edge of $\phi/8192$
1	0	0	Channel 2: Count on 8TCNT3 overflow signal* Channel 3: Count on 8TCNT2 compare match A*
		1	External clock, counted on falling edge
	1	0	External clock, counted on rising edge
		1	External clock, counted on both rising and falling edges

Note: * If the clock input of channel 2 is the 8TCNT3 overflow signal and that of channel 3 is the 8TCNT2 compare match signal, no incrementing clock is generated. Do not use this setting.

Counter clear 1 and 0

0	0	Clearing is disabled
	1	Cleared by compare match A
1	0	Cleared by compare match B/input capture B
	1	Cleared by input capture B

Timer overflow interrupt enable

0	OVI interrupt requested by OVF is disabled
1	OVI interrupt requested by OVF is enabled

Compare match interrupt enable A

0	CMIA interrupt requested by CMFA is disabled
1	CMIA interrupt requested by CMFA is enabled

Compare match interrupt enable B

0	CMIB interrupt requested by CMFB is disabled
1	CMIB interrupt requested by CMFB is enabled

8TCSR2—Timer Control/Status Register 2
8TCSR3—Timer Control/Status Register 3

H'FFF92
H'FFF93

8-bit timer channel 2
8-bit timer channel 3

8TCSR2	Bit	7	6	5	4	3	2	1	0
		CMFB	CMFA	OVF	—	OIS3	OIS2	OS1	OS0
	Initial value	0	0	0	1	0	0	0	0
	Read/Write	R/(W)*	R/(W)*	R/(W)*	—	R/W	R/W	R/W	R/W
8TCSR3	Bit	7	6	5	4	3	2	1	0
		CMFB	CMFA	OVF	ICE	OIS3	OIS2	OS1	OS0
	Initial value	0	0	0	0	0	0	0	0
	Read/Write	R/(W)*	R/(W)*	R/(W)*	R/W	R/W	R/W	R/W	R/W

Output select A1 and A0

Bit 1	Bit 0	Description
OS1	OS0	
0	0	No change at compare match A
	1	0 output at compare match A
1	0	1 output at compare match A
	1	Output toggles at compare match A

Output/input capture edge select B3 and B2

ICE in 8TCSR3	Bit 3 OIS3	Bit 2 OIS2	Description
0	0	0	No change at compare match B
		1	0 output at compare match B
	1	0	1 output at compare match B
		1	Output toggles at compare match B
1	0	0	TCORB input capture on rising edge
		1	TCORB input capture on falling edge
	1	0	TCORB input capture on both rising and falling edges

Input capture enable

0	TCORB is a compare match register
1	TCORB is an input capture register

Timer overflow flag

0	[Clearing condition] Read OVF when OVF = 1, then write 0 in OVF.
1	[Setting condition] 8TCNT overflows from H'FF to H'00.

Compare match/input capture flag A

0	[Clearing condition] Read CMFA when CMFA = 1, then write 0 in CMFA.
1	[Setting condition] 8TCNT = TCORA

Compare match/input capture flag B

0	[Clearing condition] Read CMFB when CMFB = 1, then write 0 in CMFB.
1	[Setting conditions] <ul style="list-style-type: none"> • 8TCNT = TCORB • The 8TCNT value is transferred to TCORB by an input capture signal when TCORB functions as an input capture register.

Note: * Only 0 can be written to bits 7 to 5, to clear these flags.

TCORA2—Timer Constant Register A2
TCORA3—Timer Constant Register A3

H'FFF94
H'FFF95

8-bit timer channel 2
8-bit timer channel 3

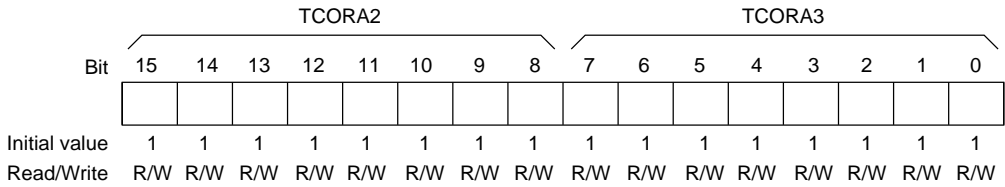

TCORB2—Timer Constant Register B2
TCORB3—Timer Constant Register B3

H'FFF96
H'FFF97

8-bit timer channel 2
8-bit timer channel 3

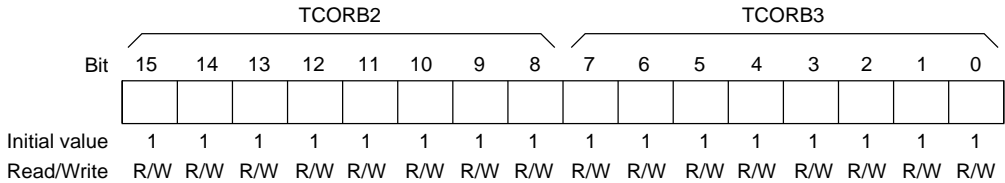

8TCNT2—Timer Counter 2
8TCNT3—Timer Counter 3

H'FFF98
H'FFF99

8-bit timer channel 2
8-bit timer channel 3

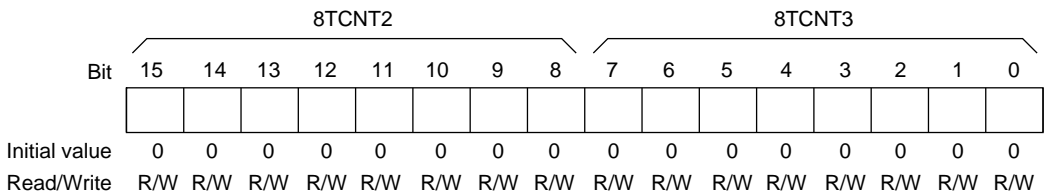

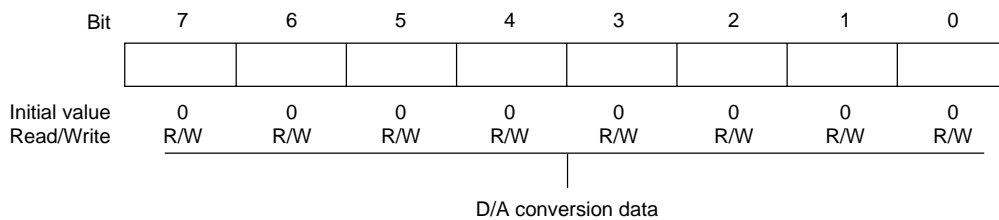
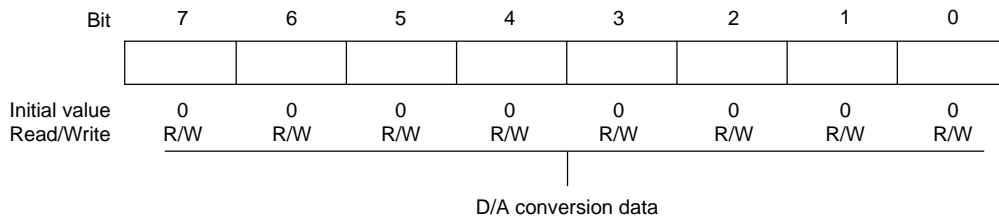
DADR0—D/A Data Register 0**H'FFF9C****D/A****DADR1—D/A Data Register 1****H'FFF9D****D/A**

Bit	7	6	5	4	3	2	1	0
	DAOE1	DAOE0	DAE	—	—	—	—	—
Initial value	0	0	0	1	1	1	1	1
Read/Write	R/W	R/W	R/W	—	—	—	—	—

D/A enable

Bit 7	Bit 6	Bit 5	Description
DAOE1	DAOE0	DAE	
0	0	—	D/A conversion is disabled in channels 0 and 1
0	1	0	D/A conversion is enabled in channel 0 D/A conversion is disabled in channel 1
0	1	1	D/A conversion is enabled in channels 0 and 1
1	0	0	D/A conversion is disabled in channel 0 D/A conversion is enabled in channel 1
1	0	1	D/A conversion is enabled in channels 0 and 1
1	1	—	D/A conversion is enabled in channels 0 and 1

D/A output enable 0

0	DA ₀ analog output is disabled
1	Channel-0 D/A conversion and DA ₀ analog output are enabled

D/A output enable 1

0	DA ₁ analog output is disabled
1	Channel-1 D/A conversion and DA ₁ analog output are enabled

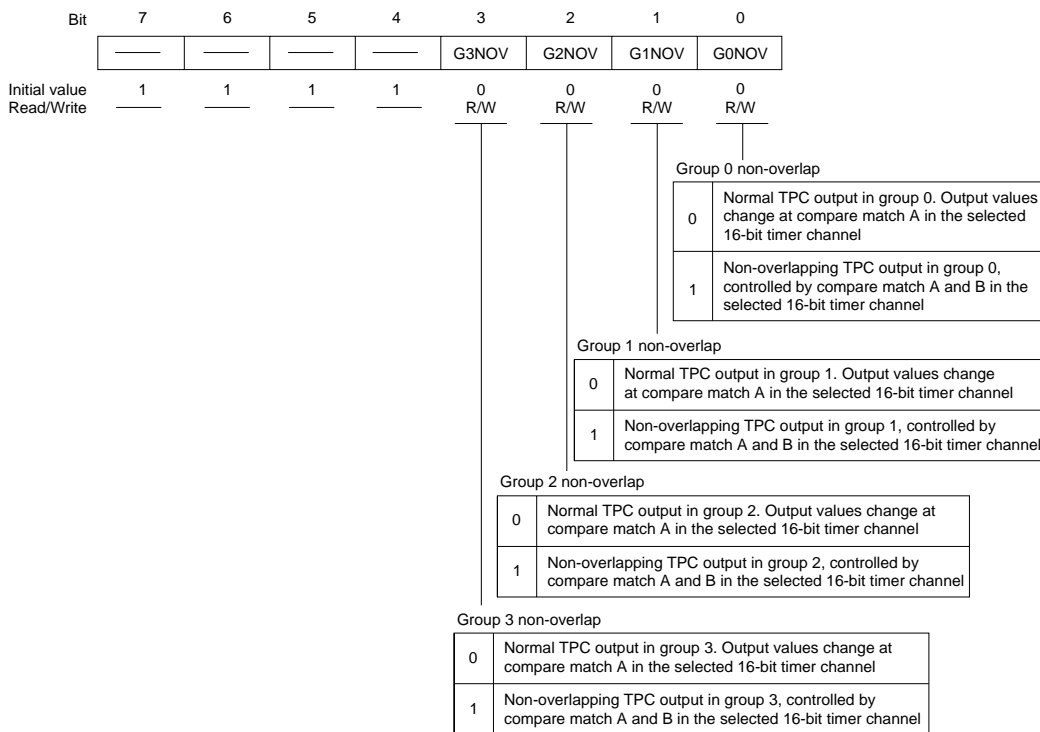

Bit	7	6	5	4	3	2	1	0
	G3CMS1	G3CMS0	G2CMS1	G2CMS0	G1CMS1	G1CMS0	G0CMS1	G0CMS0
Initial value	1	1	1	1	1	1	1	1
Read/Write	R/W	R/W	R/W	R/W	R/W	R/W	R/W	R/W

Group 0 compare match select 1 and 0

Bit 1	Bit 0	16-Bit Timer Channel Selected as Output Trigger
G0CMS1	G0CMS0	
0	0	TPC output group 0 (TP ₃ to TP ₀) is triggered by compare match in 16-bit timer channel 0
	1	TPC output group 0 (TP ₃ to TP ₀) is triggered by compare match in 16-bit timer channel 1
1	0	TPC output group 0 (TP ₃ to TP ₀) is triggered by compare match in 16-bit timer channel 2
	1	TPC output group 0 (TP ₃ to TP ₀) is triggered by compare match in 16-bit timer channel 2

Group 1 compare match select 1 and 0

Bit 3	Bit 2	16-Bit Timer Channel Selected as Output Trigger
G1CMS1	G1CMS0	
0	0	TPC output group 1 (TP ₇ to TP ₄) is triggered by compare match in 16-bit timer channel 0
	1	TPC output group 1 (TP ₇ to TP ₄) is triggered by compare match in 16-bit timer channel 1
1	0	TPC output group 1 (TP ₇ to TP ₄) is triggered by compare match in 16-bit timer channel 2
	1	TPC output group 1 (TP ₇ to TP ₄) is triggered by compare match in 16-bit timer channel 2

Group 2 compare match select 1 and 0

Bit 5	Bit 4	16-Bit Timer Channel Selected as Output Trigger
G2CMS1	G2CMS0	
0	0	TPC output group 2 (TP ₁₁ to TP ₈) is triggered by compare match in 16-bit timer channel 0
	1	TPC output group 2 (TP ₁₁ to TP ₈) is triggered by compare match in 16-bit timer channel 1
1	0	TPC output group 2 (TP ₁₁ to TP ₈) is triggered by compare match in 16-bit timer channel 2
	1	TPC output group 2 (TP ₁₁ to TP ₈) is triggered by compare match in 16-bit timer channel 2

Group 3 compare match select 1 and 0

Bit 7	Bit 6	16-Bit Timer Channel Selected as Output Trigger
G3CMS1	G3CMS0	
0	0	TPC output group 3 (TP ₁₅ to TP ₁₂) is triggered by compare match in 16-bit timer channel 0
	1	TPC output group 3 (TP ₁₅ to TP ₁₂) is triggered by compare match in 16-bit timer channel 1
1	0	TPC output group 3 (TP ₁₅ to TP ₁₂) is triggered by compare match in 16-bit timer channel 2
	1	TPC output group 3 (TP ₁₅ to TP ₁₂) is triggered by compare match in 16-bit timer channel 2

NDERB—Next Data Enable Register B**H'FFFA2****TPC**

Bit	7	6	5	4	3	2	1	0
	NDER15	NDER14	NDER13	NDER12	NDER11	NDER10	NDER9	NDER8
Initial value	0	0	0	0	0	0	0	0
Read/Write	R/W	R/W	R/W	R/W	R/W	R/W	R/W	R/W

Next data enable 15 to 8

Bits 7 to 0	Description
NDER15 to NDER8	
0	TPC outputs TP ₁₅ to TP ₈ are disabled (NDR15 to NDR8 are not transferred to PB ₇ to PB ₀)
1	TPC outputs TP ₁₅ to TP ₈ are enabled (NDR15 to NDR8 are transferred to PB ₇ to PB ₀)

NDERA—Next Data Enable Register A**H'FFFA3****TPC**

Bit	7	6	5	4	3	2	1	0
	NDER7	NDER6	NDER5	NDER4	NDER3	NDER2	NDER1	NDER0
Initial value	0	0	0	0	0	0	0	0
Read/Write	R/W	R/W	R/W	R/W	R/W	R/W	R/W	R/W

Next data enable 7 to 0

Bits 7 to 0	Description
NDER7 to NDER0	
0	TPC outputs TP ₇ to TP ₀ are disabled (NDR7 to NDR0 are not transferred to PA ₇ to PA ₀)
1	TPC outputs TP ₇ to TP ₀ are enabled (NDR7 to NDR0 are transferred to PA ₇ to PA ₀)

- Same trigger for TPC output groups 2 and 3

— Address H'FFFA4

Bit	7	6	5	4	3	2	1	0
	NDR15	NDR14	NDR13	NDR12	NDR11	NDR10	NDR9	NDR8
Initial value	0	0	0	0	0	0	0	0
Read/Write	R/W	R/W	R/W	R/W	R/W	R/W	R/W	R/W

Store the next output data for TPC output group 3 Store the next output data for TPC output group 2

— Address H'FFFA6

Bit	7	6	5	4	3	2	1	0
	_____	_____	_____	_____	_____	_____	_____	_____
Initial value	1	1	1	1	1	1	1	1
Read/Write	_____	_____	_____	_____	_____	_____	_____	_____

- Different triggers for TPC output groups 2 and 3

— Address H'FFFA4

Bit	7	6	5	4	3	2	1	0
	NDR15	NDR14	NDR13	NDR12	_____	_____	_____	_____
Initial value	0	0	0	0	1	1	1	1
Read/Write	R/W	R/W	R/W	R/W	_____	_____	_____	_____

Store the next output data for TPC output group 3

— Address H'FFFA6

Bit	7	6	5	4	3	2	1	0
	_____	_____	_____	_____	NDR11	NDR10	NDR9	NDR8
Initial value	1	1	1	1	0	0	0	0
Read/Write	_____	_____	_____	_____	R/W	R/W	R/W	R/W

Store the next output data for TPC output group 2

- Same trigger for TPC output groups 0 and 1

— Address H'FFFA5

Bit	7	6	5	4	3	2	1	0
	NDR7	NDR6	NDR5	NDR4	NDR3	NDR2	NDR1	NDR0
Initial value	0	0	0	0	0	0	0	0
Read/Write	R/W	R/W	R/W	R/W	R/W	R/W	R/W	R/W

Store the next output data for TPC output group 1

Store the next output data for TPC output group 0

— Address H'FFFA7

Bit	7	6	5	4	3	2	1	0
	—	—	—	—	—	—	—	—
Initial value	1	1	1	1	1	1	1	1
Read/Write	—	—	—	—	—	—	—	—

- Different triggers for TPC output groups 0 and 1

— Address H'FFFA5

Bit	7	6	5	4	3	2	1	0
	NDR7	NDR6	NDR5	NDR4	—	—	—	—
Initial value	0	0	0	0	1	1	1	1
Read/Write	R/W	R/W	R/W	R/W	—	—	—	—

Store the next output data for TPC output group 1

— Address H'FFFA7

Bit	7	6	5	4	3	2	1	0
	—	—	—	—	NDR3	NDR2	NDR1	NDR0
Initial value	1	1	1	1	0	0	0	0
Read/Write	—	—	—	—	R/W	R/W	R/W	R/W

Store the next output data for TPC output group 0

Bit	7	6	5	4	3	2	1	0
	C/ \bar{A}	CHR	PE	O/ \bar{E}	STOP	MP	CKS1	CKS0
Initial value	0	0	0	0	0	0	0	0
Read/Write	R/W	R/W	R/W	R/W	R/W	R/W	R/W	R/W

Clock select 1 and 0

Bit 1	Bit 0	Clock Source
CKS1	CKS0	
0	0	ϕ clock
	1	$\phi/4$ clock
1	0	$\phi/16$ clock
	1	$\phi/64$ clock

Multiprocessor mode

0	Multiprocessor function disabled
1	Multiprocessor function enabled

Stop bit length

0	One stop bit
1	Two stop bits

Parity mode

0	Even parity
1	Odd parity

Parity enable

0	Parity bit is not added or checked
1	Parity bit is added and checked

Character length

0	8-bit data
1	7-bit data

Communication mode (for serial communication interface)

0	Asynchronous mode
1	Synchronous mode

GSM mode (for smart card interface)

0	TEND flag is set 12.5 etu* after start bit
1	TEND flag is set 11.0 etu* after start bit

Note: * etu: Elementary time unit (time required to transmit one bit)

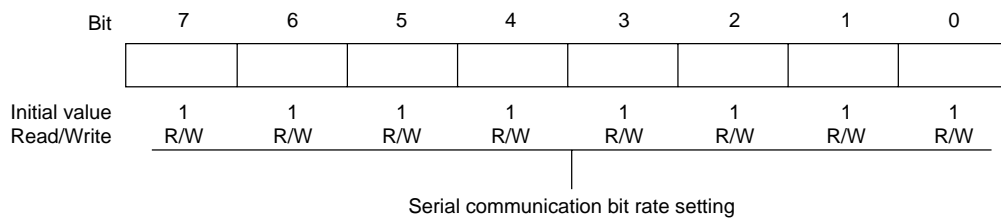
BRR—Bit Rate Register**H'FFFB1****SCI0**

Bit	7	6	5	4	3	2	1	0
	TIE	RIE	TE	RE	MPIE	TEIE	CKE1	CKE0
Initial value	0	0	0	0	0	0	0	0
Read/Write	R/W	R/W	R/W	R/W	R/W	R/W	R/W	R/W

Receive enable

0	Receiving is disabled
1	Receiving is enabled

Transmit enable

0	Transmitting is disabled
1	Transmitting is enabled

Clock enable 1 and 0 (for serial communication interface)

Bit 1	Bit 0	Description	
CKE1	CKE0		
0	0	Asynchronous mode	Internal clock, SCK pin available for generic I/O
		Synchronous mode	Internal clock, SCK pin used for serial clock output
	1	Asynchronous mode	Internal clock, SCK pin used for clock output
		Synchronous mode	Internal clock, SCK pin used for serial clock output
1	0	Asynchronous mode	External clock, SCK pin used for clock input
		Synchronous mode	External clock, SCK pin used for serial clock input
	1	Asynchronous mode	External clock, SCK pin used for clock input
		Synchronous mode	External clock, SCK pin used for serial clock input

Clock enable 1 and 0 (for smart card interface)

SMR	Bit 1	Bit 0	Description
GM	CKE1	CKE0	
0	0	0	SCK pin available for generic I/O
		1	SCK pin used for clock output
1	0	0	SCK pin output fixed low
		1	SCK pin used for clock output
	1	0	SCK pin output fixed high
		1	SCK pin used for clock output

Transmit-end interrupt enable

0	Transmit-end interrupt requests (TEI) are disabled
1	Transmit-end interrupt requests (TEI) are enabled

Multiprocessor interrupt enable

0	Multiprocessor interrupts are disabled (normal receive operation)
1	Multiprocessor interrupts are enabled

Receive interrupt enable

0	Receive-data-full (RXI) and receive-error (ERI) interrupt requests are disabled
1	Receive-data-full (RXI) and receive-error (ERI) interrupt requests are enabled

Transmit interrupt enable

0	Transmit-data-empty interrupt request (TXI) is disabled
1	Transmit-data-empty interrupt request (TXI) is enabled

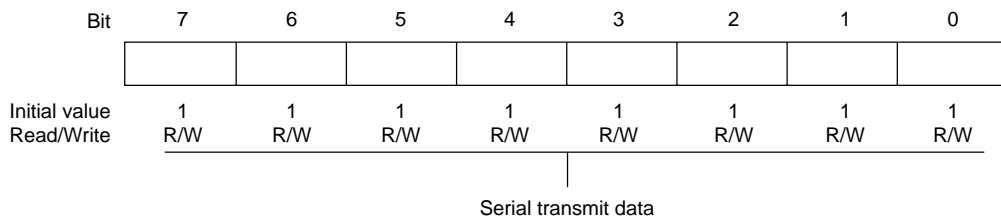

Bit	7	6	5	4	3	2	1	0
	TDRE	RDRF	ORER	FER/ERS	PER	TEND	MPB	MPBT
Initial value	1	0	0	0	0	1	0	0
Read/Write	R/(W)*	R/(W)*	R/(W)*	R/(W)*	R/(W)*	R	R	R/W
								Multiprocessor bit transfer 0 Multiprocessor bit value in transmit data is 0 1 Multiprocessor bit value in transmit data is 1 Multiprocessor bit 0 Multiprocessor bit value in receive data is 0 1 Multiprocessor bit value in receive data is 1
								Transmit end (for serial communication interface) 0 [Clearing conditions] • Read TDRE when TDRE = 1, then write 0 in TDRE. • The DMAC writes data in TDR. 1 [Setting conditions] • Reset or transition to standby mode • TE is cleared to 0 in SCR. • TDRE is 1 when last bit of 1-byte serial character is transmitted.
								Transmit end (for smart card interface) 0 [Clearing conditions] • Read TDRE when TDRE = 1, then write 0 in TDRE. • The DMAC writes data in TDR. 1 [Setting conditions] • Reset or transition to standby mode • TE is cleared to 0 in SCR and FER/ERS is cleared to 0. • TDRE is 1 and FER/ERS is 0 (normal transmission) 2.5 etu* (when GM = 0) or 1.0 etu (when GM = 1) after 1-byte serial character is transmitted.
								Note: * etu: Elementary time unit (time required to transmit one bit)
								Parity error 0 [Clearing conditions] • Reset or transition to standby mode • Read PER when PER = 1, then write 0 in PER. 1 [Setting condition] Parity error (parity of receive data does not match parity setting of O/E bit in SMR)
								Framing error (for serial communication interface) 0 [Clearing conditions] • Reset or transition to standby mode • Read FER when FER = 1, then write 0 in FER. 1 [Setting condition] Framing error (stop bit is 0)
								Error signal status (for smart card interface) 0 [Clearing conditions] • Reset or transition to standby mode • Read ERS when ERS = 1, then write 0 in ERS. 1 [Setting condition] A low error signal is received.
								Overrun error 0 [Clearing conditions] • Reset or transition to standby mode • Read ORER when ORER = 1, then write 0 in ORER. 1 [Setting condition] Overrun error (reception of the next serial data ends when RDRF = 1)
								Receive data register full 0 [Clearing conditions] • Reset or transition to standby mode • Read RDRF when RDRF = 1, then write 0 in RDRF. • The DMAC reads data from RDR. 1 [Setting condition] Serial data is received normally and transferred from RSR to RDR.
								Transmit data register empty 0 [Clearing conditions] • Read TDRE when TDRE = 1, then write 0 in TDRE. • The DMAC writes data in TDR. 1 [Setting conditions] • Reset or transition to standby mode • TE is 0 in SCR. • Data is transferred from TDR to TSR, enabling new data to be written in TDR

Note: * Only 0 can be written, to clear the flag.

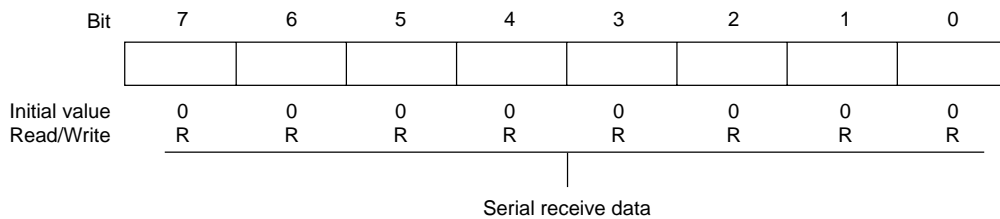
RDR—Receive Data Register**H'FFFB5****SCI0**

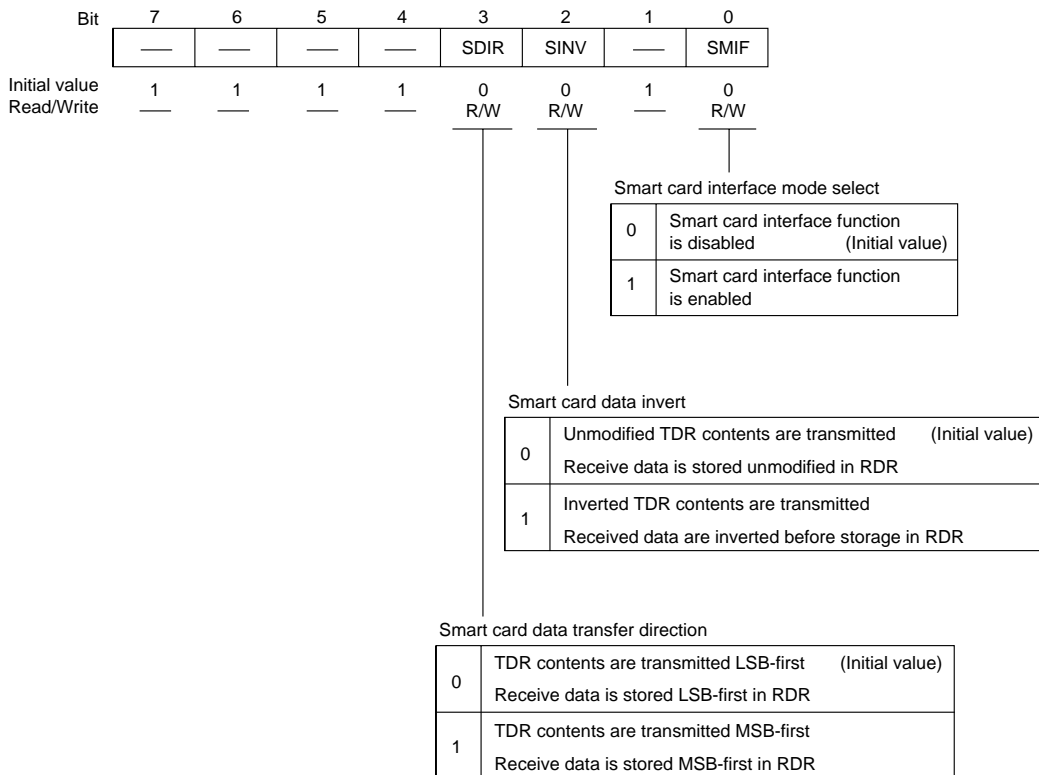

SMR—Serial Mode Register					H'FFFB8	SCI1		
Bit	7	6	5	4	3	2	1	0
	C/ \bar{A}	CHR	PE	O/ \bar{E}	STOP	MP	CKS1	CKS0
Initial value	0	0	0	0	0	0	0	0
Read/Write	R/W	R/W	R/W	R/W	R/W	R/W	R/W	R/W
Note: Bit functions are the same as for SCI0.								

BRR—Bit Rate Register					H'FFFB9	SCI1		
Bit	7	6	5	4	3	2	1	0
Initial value	1	1	1	1	1	1	1	1
Read/Write	R/W	R/W	R/W	R/W	R/W	R/W	R/W	R/W
Note: Bit functions are the same as for SCI0.								

SCR—Serial Control Register					H'FFFB A	SCI1		
Bit	7	6	5	4	3	2	1	0
	TIE	RIE	TE	RE	MPIE	TEIE	CKE1	CKE0
Initial value	0	0	0	0	0	0	0	0
Read/Write	R/W	R/W	R/W	R/W	R/W	R/W	R/W	R/W
Note: Bit functions are the same as for SCI0.								

TDR—Transmit Data Register						H'FFFBB	SCI1	
Bit	7	6	5	4	3	2	1	0
Initial value	1	1	1	1	1	1	1	1
Read/Write	R/W	R/W	R/W	R/W	R/W	R/W	R/W	R/W

Note: Bit functions are the same as for SCI0.

SSR—Serial Status Register						H'FFFBC	SCI1	
Bit	7	6	5	4	3	2	1	0
	TDRE	RDRF	ORER	FER/ERS	PER	TEND	MPB	MPBT
Initial value	0	0	0	0	0	1	0	0
Read/Write	R/(W)*	R/(W)*	R/(W)*	R/(W)*	R/(W)*	R	R	R/W

Note: Bit functions are the same as for SCI0.

* Only 0 can be written, to clear the flag.

RDR—Receive Data Register						H'FFFBD	SCI1	
Bit	7	6	5	4	3	2	1	0
Initial value	0	0	0	0	0	0	0	0
Read/Write	R	R	R	R	R	R	R	R

Note: Bit functions are the same as for SCI0.

SCMR—Smart Card Mode Register**H'FFFBE****SCI1**

Bit	7	6	5	4	3	2	1	0
	—	—	—	—	SDIR	SINV	—	SMIF
Initial value	1	1	1	1	0	0	1	0
Read/Write	—	—	—	—	R/W	R/W	—	R/W

Note: Bit functions are the same as for SCI0.

SMR—Serial Mode Register					H'FFFC0	SCI2		
Bit	7	6	5	4	3	2	1	0
	C/ \bar{A}	CHR	PE	O/ \bar{E}	STOP	MP	CKS1	CKS0
Initial value	0	0	0	0	0	0	0	0
Read/Write	R/W	R/W	R/W	R/W	R/W	R/W	R/W	R/W

Note: Bit functions are the same as for SCI0.

BRR—Bit Rate Register					H'FFFC1	SCI2		
Bit	7	6	5	4	3	2	1	0
Initial value	1	1	1	1	1	1	1	1
Read/Write	R/W	R/W	R/W	R/W	R/W	R/W	R/W	R/W

Note: Bit functions are the same as for SCI0.

SCR—Serial Control Register					H'FFFC2	SCI2		
Bit	7	6	5	4	3	2	1	0
	TIE	RIE	TE	RE	MPIE	TEIE	CKE1	CKE0
Initial value	0	0	0	0	0	0	0	0
Read/Write	R/W	R/W	R/W	R/W	R/W	R/W	R/W	R/W

Note: Bit functions are the same as for SCI0.

TDR—Transmit Data Register					H'FFFC3	SCI2		
Bit	7	6	5	4	3	2	1	0
Initial value	1	1	1	1	1	1	1	1
Read/Write	R/W	R/W	R/W	R/W	R/W	R/W	R/W	R/W

Note: Bit functions are the same as for SCI0.

SSR—Serial Status Register					H'FFFC4	SCI2		
Bit	7	6	5	4	3	2	1	0
	TDRE	RDRF	ORER	FER/ERS	PER	TEND	MPB	MPBT
Initial value	1	0	0	0	0	1	0	0
Read/Write	R/(W)*	R/(W)*	R/(W)*	R/(W)*	R/(W)*	R	R	R/W

Note: Bit functions are the same as for SCI0.
* Only 0 can be written, to clear the flag.

RDR—Receive Data Register					H'FFFC5	SCI2		
Bit	7	6	5	4	3	2	1	0
Initial value	0	0	0	0	0	0	0	0
Read/Write	R	R	R	R	R	R	R	R

Note: Bit functions are the same as for SCI0.

SCMR—Smart Card Mode Register**H'FFFC6****SCI2**

Bit	7	6	5	4	3	2	1	0
	—	—	—	—	SDIR	SINV	—	SMIF
Initial value	1	1	1	1	0	0	1	0
Read/Write	—	—	—	—	R/W	R/W	—	R/W

Note: Bit functions are the same as for SCI0.

P4DR—Port 4 Data Register**H'FFFD3****Port 4**

Bit	7	6	5	4	3	2	1	0
	P47	P46	P45	P44	P43	P42	P41	P40
Initial value	0	0	0	0	0	0	0	0
Read/Write	R/W	R/W	R/W	R/W	R/W	R/W	R/W	R/W

Data for port 4 pins

P6DR—Port 6 Data Register**H'FFFD5****Port 6**

Bit	7	6	5	4	3	2	1	0
	P67	P66	P65	P64	P63	P62	P61	P60
Initial value	*	0	0	0	0	0	0	0
Read/Write	R	R/W	R/W	R/W	R/W	R/W	R/W	R/W

Data for port 6 pins

Note: * Determined by pin P6₇.

P7DR—Port 7 Data Register				H'FFFD6		Port 7		
Bit	7	6	5	4	3	2	1	0
	P77	P76	P75	P74	P73	P72	P71	P70
Initial value	—	*	—	*	—	*	—	*
Read/Write	R	R	R	R	R	R	R	R
 Data for port 7 pins								
Note: * Determined by pins P77 to P70.								

P8DR—Port 8 Data Register				H'FFFD7		Port 8		
Bit	7	6	5	4	3	2	1	0
	—	—	—	P84	P83	P82	P81	P80
Initial value	1	1	1	0	0	0	0	0
Read/Write	—	—	—	R/W	R/W	R/W	R/W	R/W
 Data for port 8 pins								

P9DR—Port 9 Data Register					H'FFFD8	Port 9		
Bit	7	6	5	4	3	2	1	0
	—	—	P95	P94	P93	P92	P91	P90
Initial value	1	1	0	0	0	0	0	0
Read/Write	—	—	R/W	R/W	R/W	R/W	R/W	R/W
<div style="border-top: 1px solid black; width: 100%; margin-top: 5px;"></div> Data for port 9 pins								

PADR—Port A Data Register					H'FFFD9	Port A		
Bit	7	6	5	4	3	2	1	0
	PA7	PA6	PA5	PA4	PA3	PA2	PA1	PA0
Initial value	0	0	0	0	0	0	0	0
Read/Write	R/W	R/W	R/W	R/W	R/W	R/W	R/W	R/W
<div style="border-top: 1px solid black; width: 100%; margin-top: 5px;"></div> Data for port A pins								

PBDR—Port B Data Register					H'FFFDA	Port B		
Bit	7	6	5	4	3	2	1	0
	PB7	PB6	PB5	PB4	PB3	PB2	PB1	PB0
Initial value	0	0	0	0	0	0	0	0
Read/Write	R/W	R/W	R/W	R/W	R/W	R/W	R/W	R/W
<div style="border-top: 1px solid black; width: 100%; margin-top: 5px;"></div> Data for port B pins								

ADDRA H/L—A/D Data Register A H/L											H'FFFE0, H'FFFE1				A/D	
Bit	15	14	13	12	11	10	9	8	7	6	5	4	3	2	1	0
	AD9	AD8	AD7	AD6	AD5	AD4	AD3	AD2	AD1	AD0	—	—	—	—	—	—
Initial value	0	0	0	0	0	0	0	0	0	0	0	0	0	0	0	0
Read/Write	R	R	R	R	R	R	R	R	R	R	R	R	R	R	R	R
	└──┘										└──┘					
	ADDRAH										ADDRAL					
└──┘																
A/D conversion data																
10-bit data giving an A/D conversion result																

ADDRB H/L—A/D Data Register B H/L											H'FFFE2, H'FFFE3				A/D	
Bit	15	14	13	12	11	10	9	8	7	6	5	4	3	2	1	0
	AD9	AD8	AD7	AD6	AD5	AD4	AD3	AD2	AD1	AD0	—	—	—	—	—	—
Initial value	0	0	0	0	0	0	0	0	0	0	0	0	0	0	0	0
Read/Write	R	R	R	R	R	R	R	R	R	R	R	R	R	R	R	R
	└──┘										└──┘					
	ADDRBH										ADDRBL					
└──┘																
A/D conversion data																
10-bit data giving an A/D conversion result																

ADDRC H/L—A/D Data Register C H/L											H'FFFE4, H'FFFE5				A/D	
Bit	15	14	13	12	11	10	9	8	7	6	5	4	3	2	1	0
	AD9	AD8	AD7	AD6	AD5	AD4	AD3	AD2	AD1	AD0	—	—	—	—	—	—
Initial value	0	0	0	0	0	0	0	0	0	0	0	0	0	0	0	0
Read/Write	R	R	R	R	R	R	R	R	R	R	R	R	R	R	R	R
	ADDRCH										ADDRCL					
<hr style="width:100%; border:0.5px solid black;"/> A/D conversion data 10-bit data giving an A/D conversion result																

ADDRD H/L—A/D Data Register D H/L											H'FFFE6, H'FFFE7				A/D	
Bit	15	14	13	12	11	10	9	8	7	6	5	4	3	2	1	0
	AD9	AD8	AD7	AD6	AD5	AD4	AD3	AD2	AD1	AD0	—	—	—	—	—	—
Initial value	0	0	0	0	0	0	0	0	0	0	0	0	0	0	0	0
Read/Write	R	R	R	R	R	R	R	R	R	R	R	R	R	R	R	R
	ADDRDH										ADDRDL					
<hr style="width:100%; border:0.5px solid black;"/> A/D conversion data 10-bit data giving an A/D conversion result																

ADCR H/L—A/D Control Register								H'FFFE9		A/D
Bit	7	6	5	4	3	2	1	0		
	TRGE	—	—	—	—	—	—	—		
Initial value	0	1	1	1	1	1	1	0		
Read/Write	R/W	—	—	—	—	—	—	R/W		
<hr style="width:100%; border:0.5px solid black;"/> Trigger Enable										
0		A/D conversion start by external trigger or 8-bit timer compare match is disabled								
1		A/D conversion is started by falling edge of external trigger signal (ADTRG) or 8-bit timer compare match								

Bit	7	6	5	4	3	2	1	0
	ADF	ADIE	ADST	SCAN	CKS	CH2	CH1	CH0
Initial value	0	0	0	0	0	0	0	0
Read/Write	R/(W)*	R/W	R/W	R/W	R/W	R/W	R/W	R/W

Clock select

0	Conversion time = 134 states (maximum)
1	Conversion time = 70 states (maximum)

Channel select

Group Selection	Channel Selection	Description	
		Single Mode	Scan Mode
0	0	0	AN ₀
		1	AN ₁
	1	0	AN ₂
		1	AN ₃
1	0	0	AN ₄
		1	AN ₅
	1	0	AN ₆
		1	AN ₇

Scan mode

0	Single mode
1	Scan mode

A/D start

0	A/D conversion is stopped
1	<ol style="list-style-type: none"> Single mode: A/D conversion starts; ADST is automatically cleared to 0 when conversion ends Scan mode: A/D conversion starts and continues, cycling among the selected channels ADST is cleared to 0 by software, by a reset, or by a transition to standby mode

A/D interrupt enable

0	A/D end interrupt request is disabled
1	A/D end interrupt request is enabled

A/D end flag

0	<p>[Clearing condition]</p> <ul style="list-style-type: none"> Read ADF when ADF = 1, then write 0 in ADF The DMAC is activated by an ADI interrupt
1	<p>[Setting conditions]</p> <ul style="list-style-type: none"> Single mode: A/D conversion ends Scan mode: A/D conversion ends in all selected channels

Note: * Only 0 can be written, to clear the flag.

Appendix C I/O Port Block Diagrams

C.1 Port 4 Block Diagram

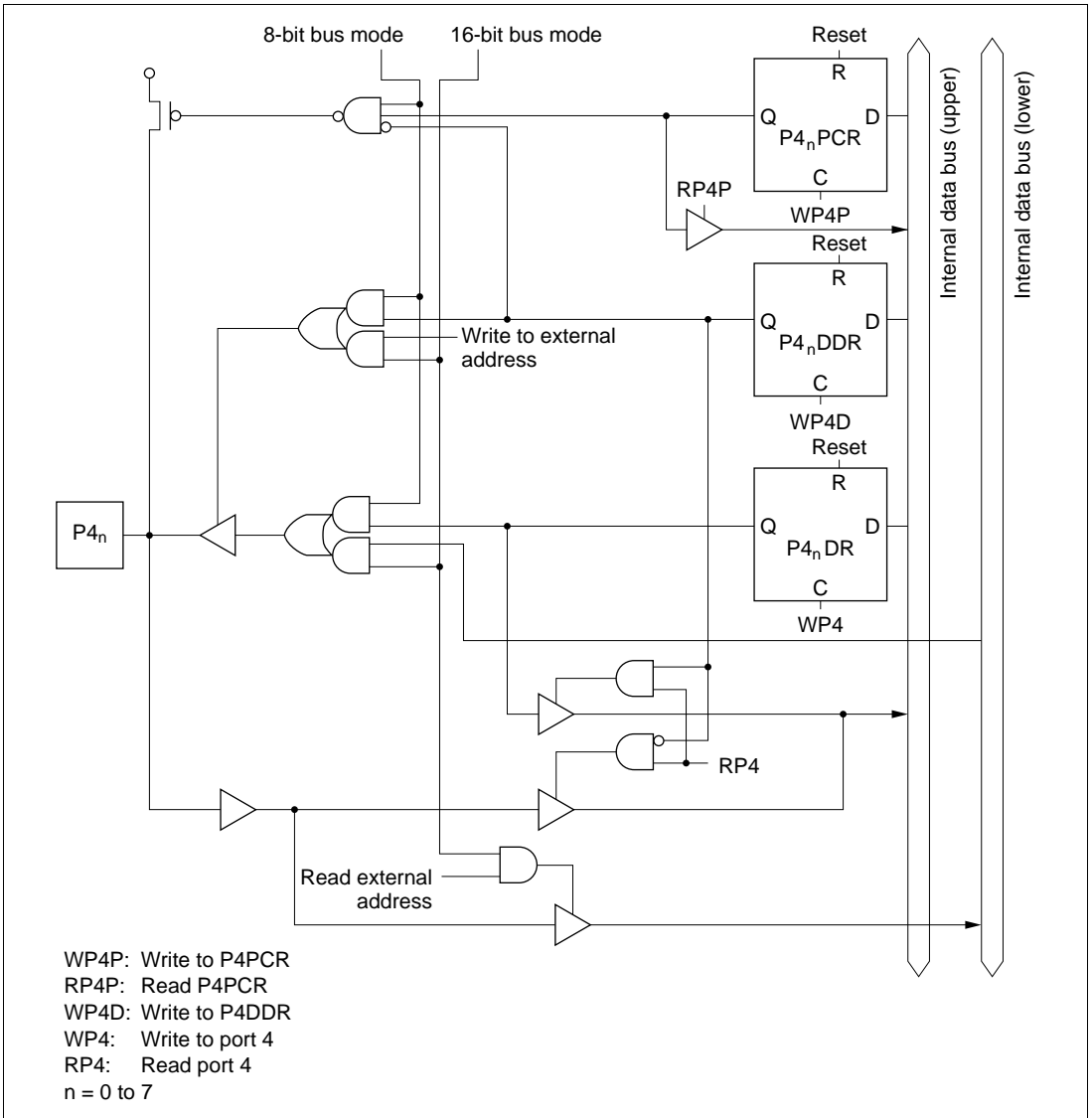

Figure C.1 Port 4 Block Diagram

C.2 Port 6 Block Diagrams

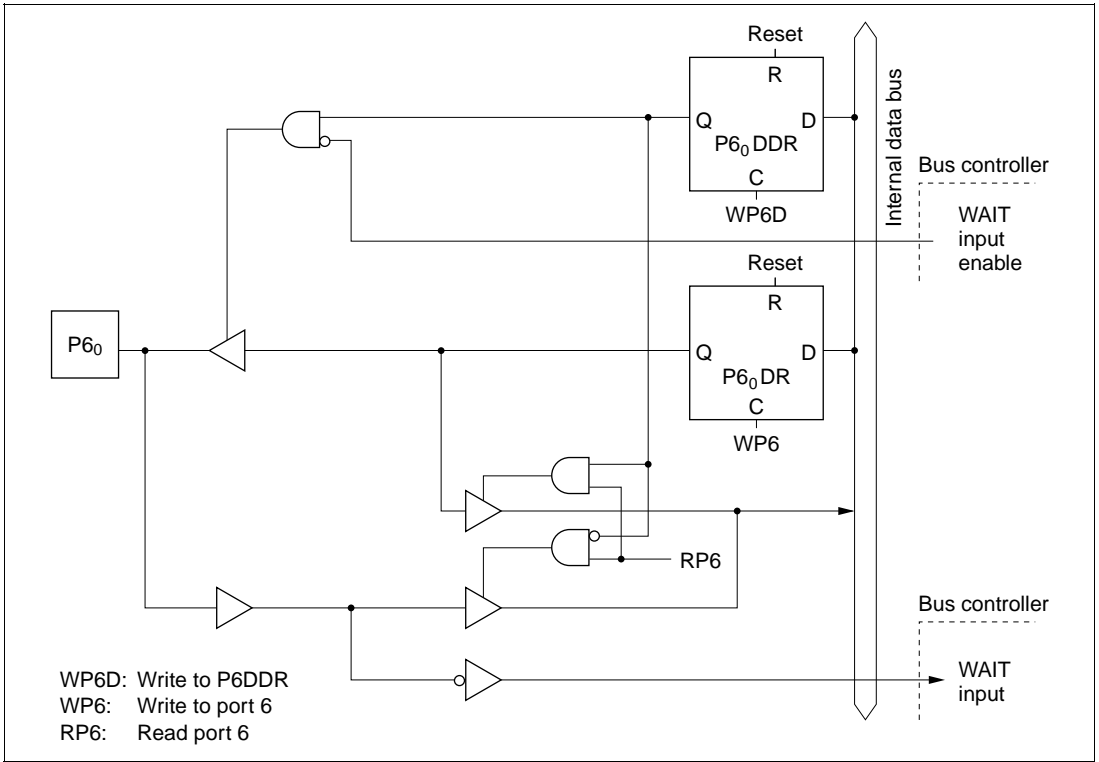

Figure C.2 (a) Port 6 Block Diagram (Pin P6₀)

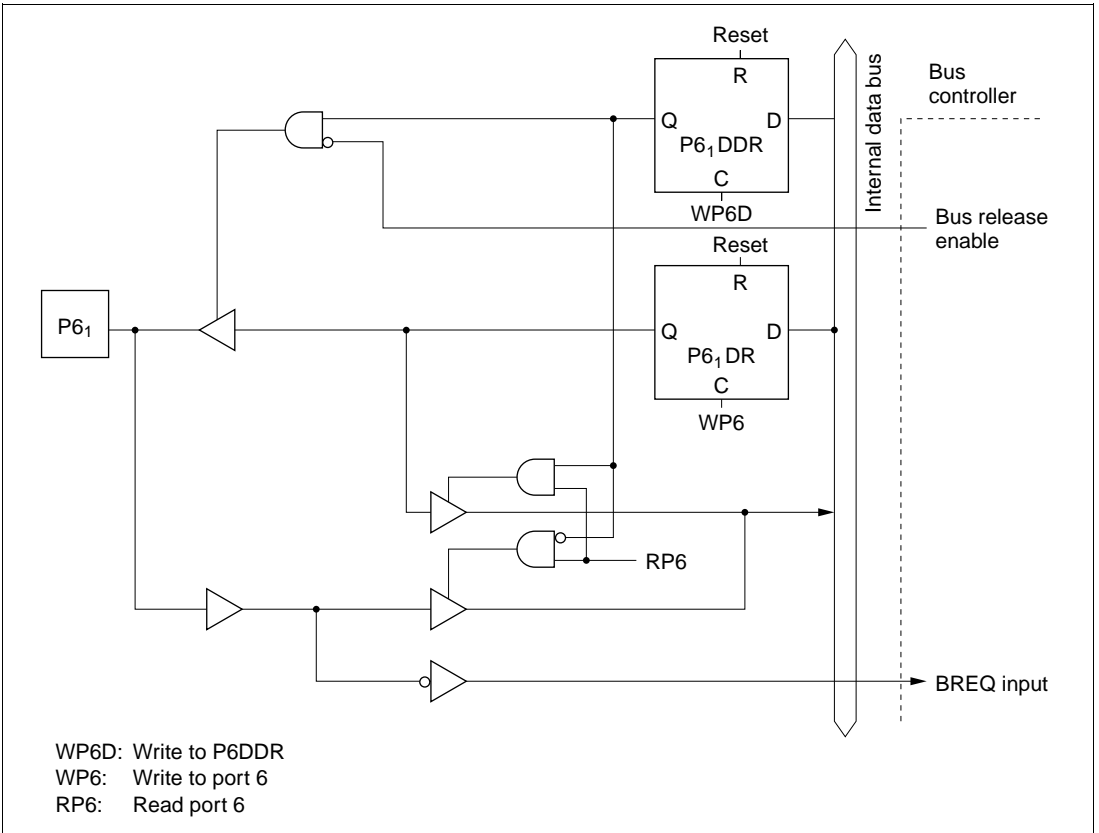

Figure C.2 (b) Port 6 Block Diagram (Pin P6₁)

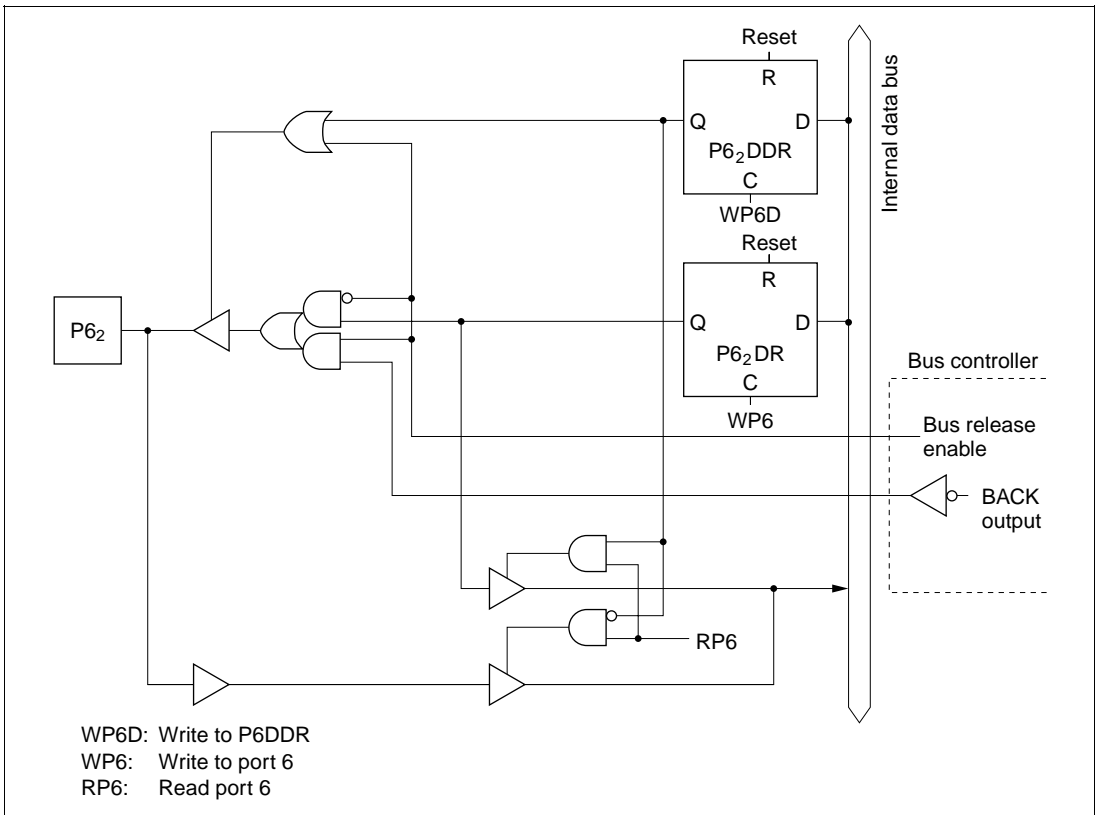

Figure C.2 (c) Port 6 Block Diagram (Pin P6₂)

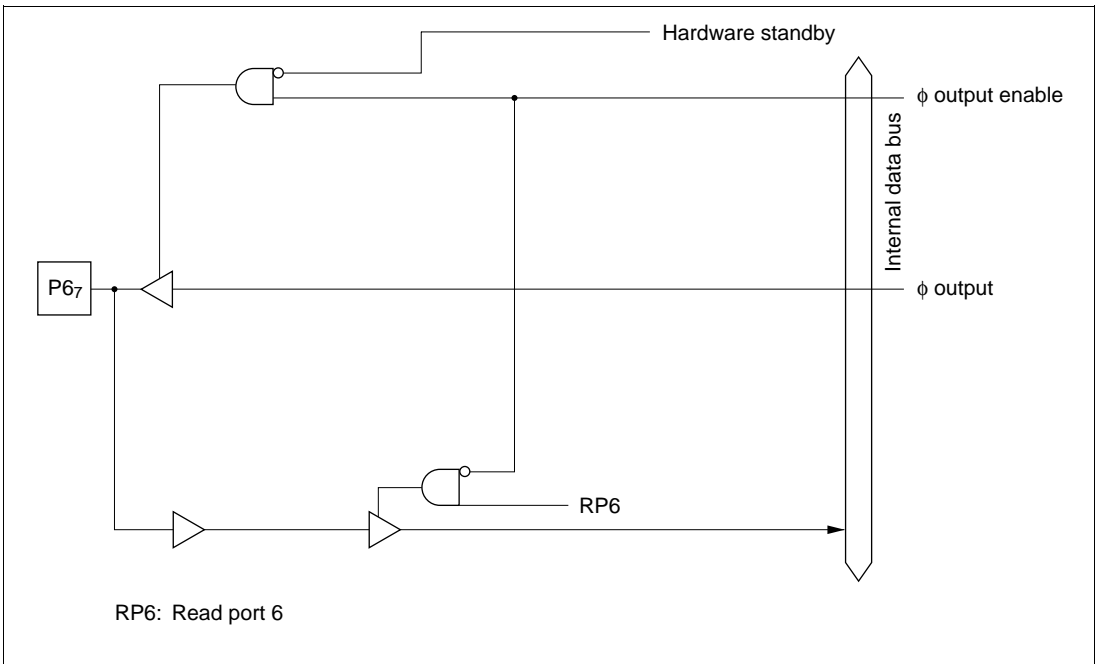

Figure C.2 (d) Port 6 Block Diagram (Pin P6₇)

C.3 Port 7 Block Diagrams

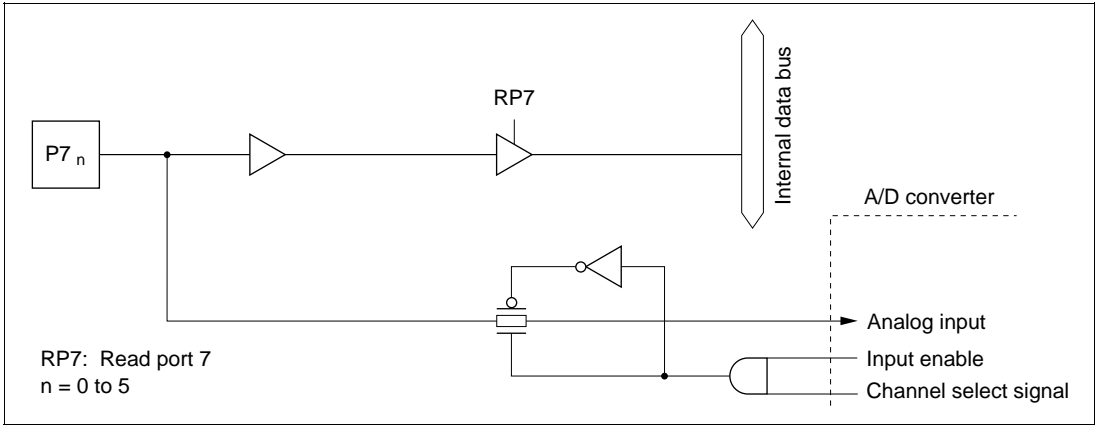

Figure C.3 (a) Port 7 Block Diagram (Pins P7₀ to P7₅)

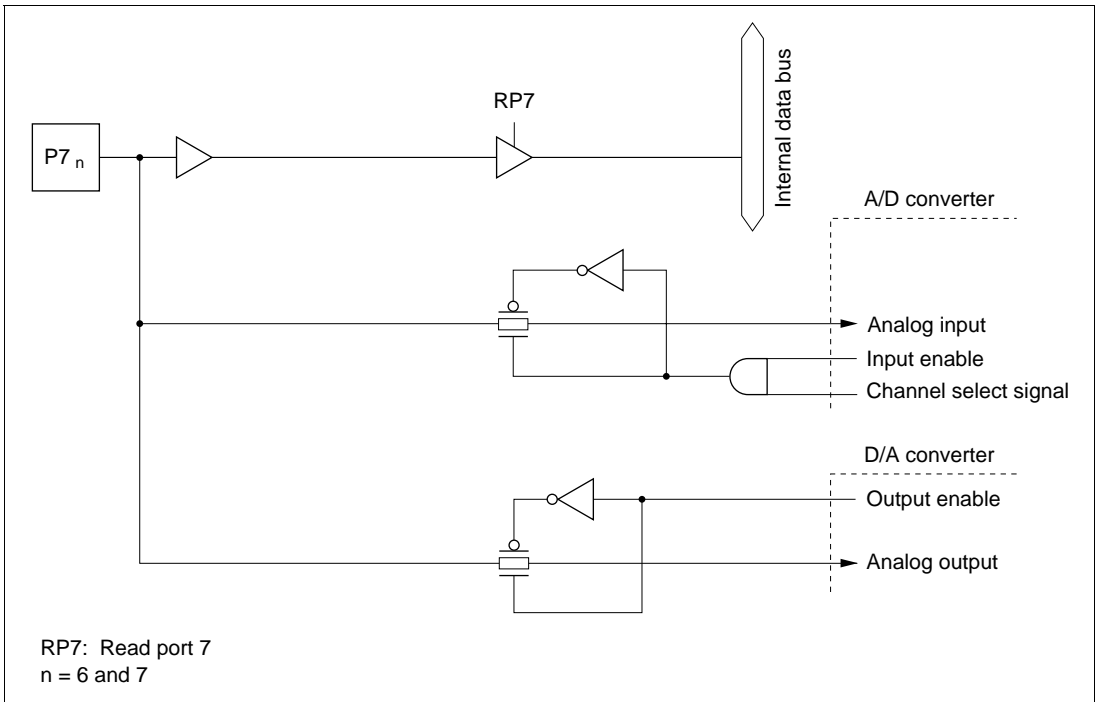

Figure C.3 (b) Port 7 Block Diagram (Pins P7₆ and P7₇)

C.4 Port 8 Block Diagrams

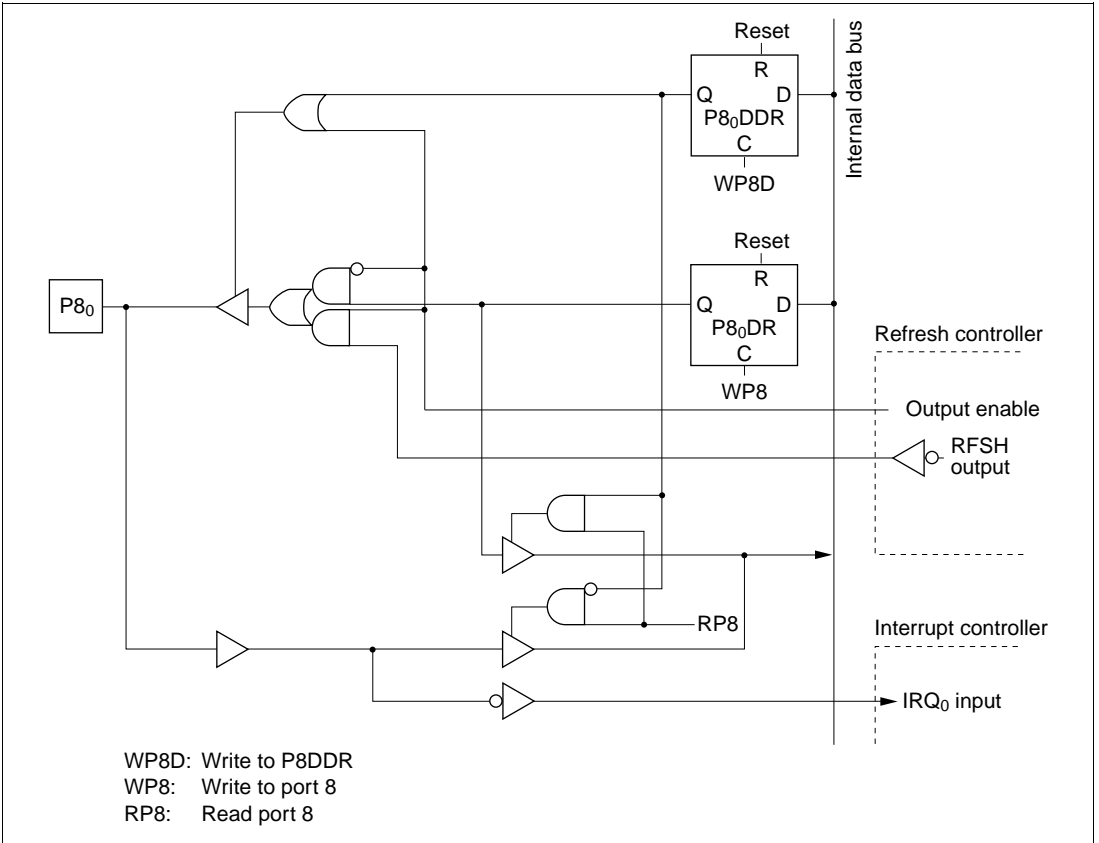

Figure C.4 (a) Port 8 Block Diagram (Pin P8₀)

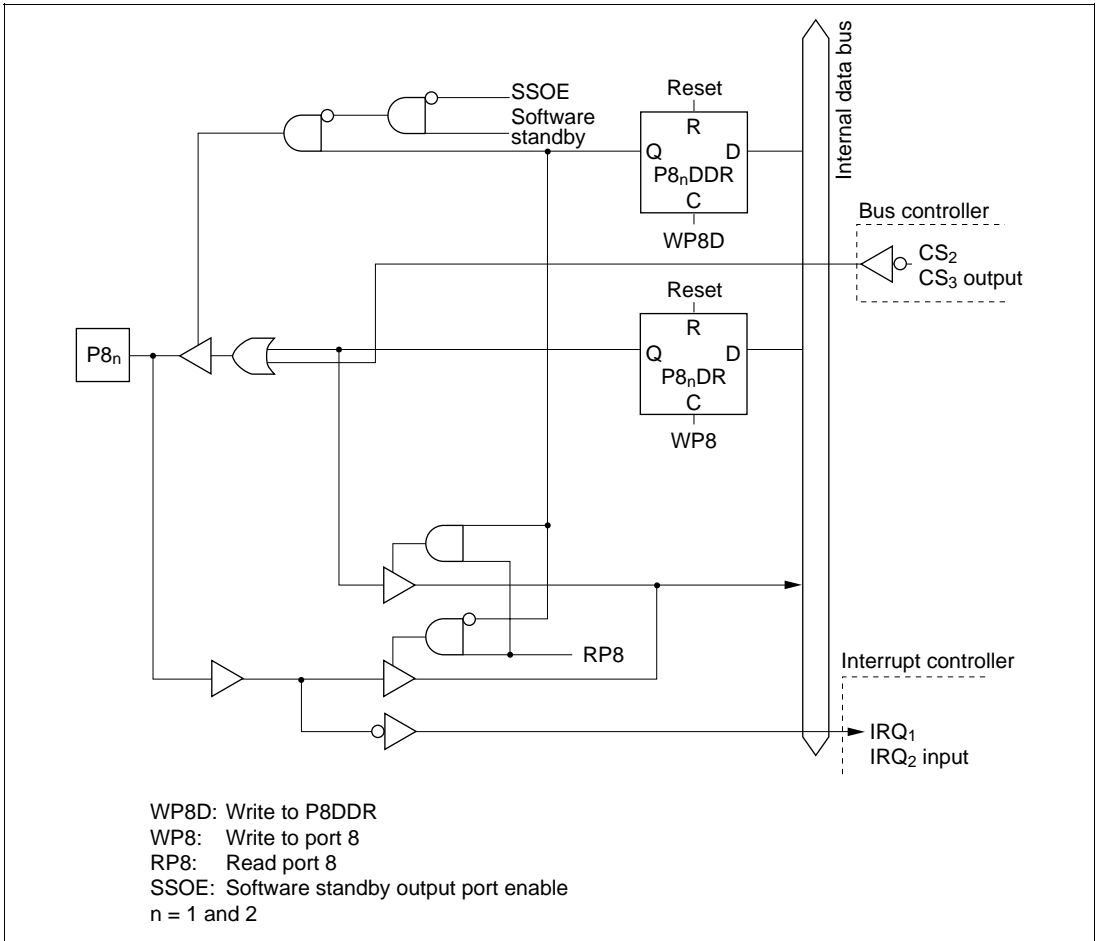
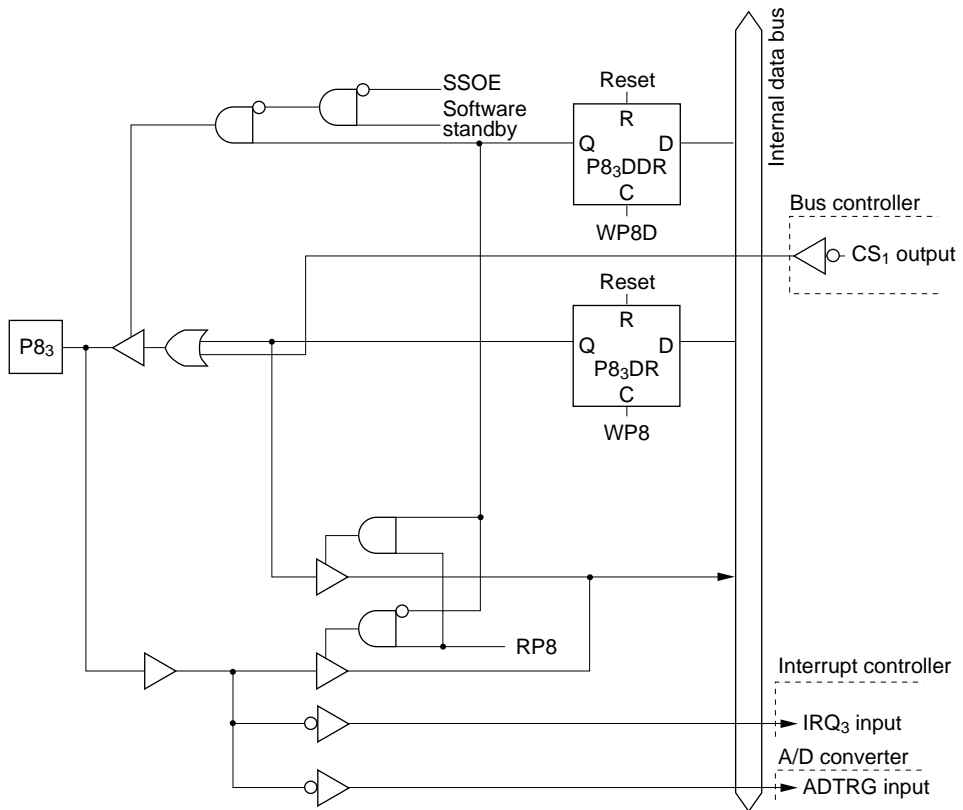

Figure C.4 (b) Port 8 Block Diagram (Pins $P8_1$, $P8_2$)



WP8D: Write to P8DDR
 WP8: Write to port 8
 RP8: Read port 8
 SSOE: Software standby output port enable

Figure C.4 (c) Port 8 Block Diagram (Pin P8₃)

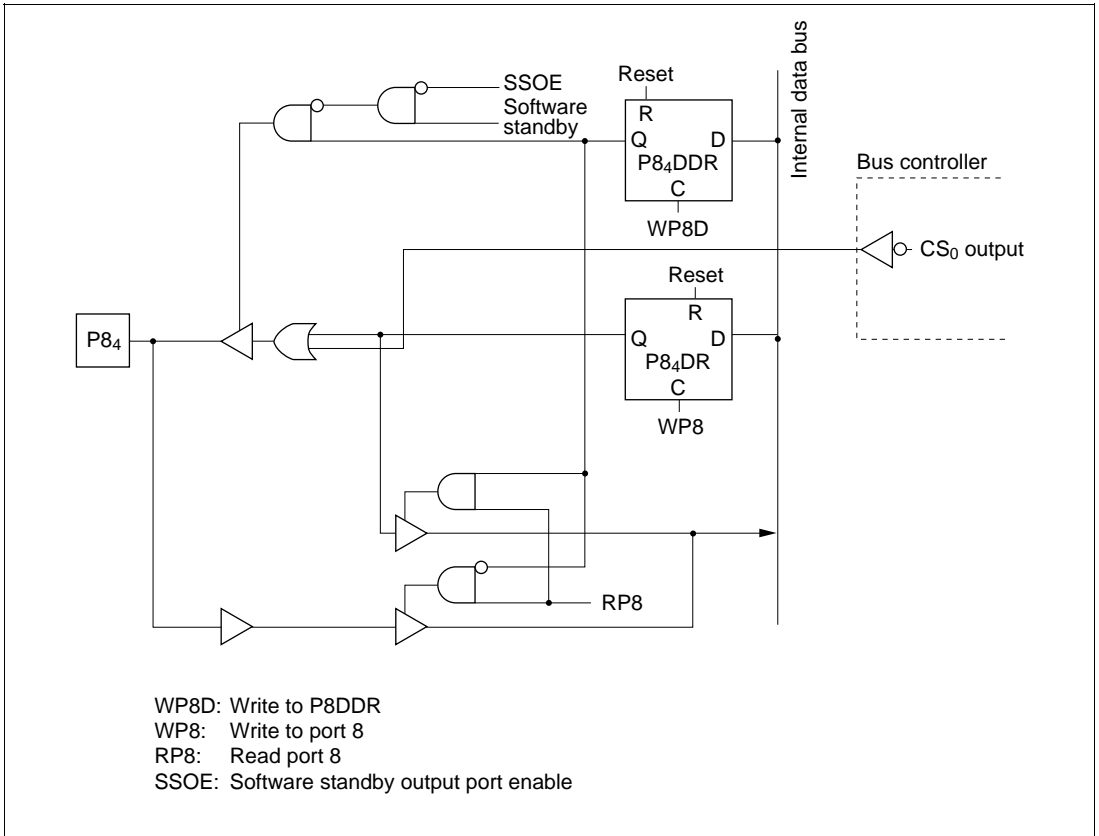

Figure C.4 (d) Port 8 Block Diagram (Pin P8₄)

C.5 Port 9 Block Diagrams

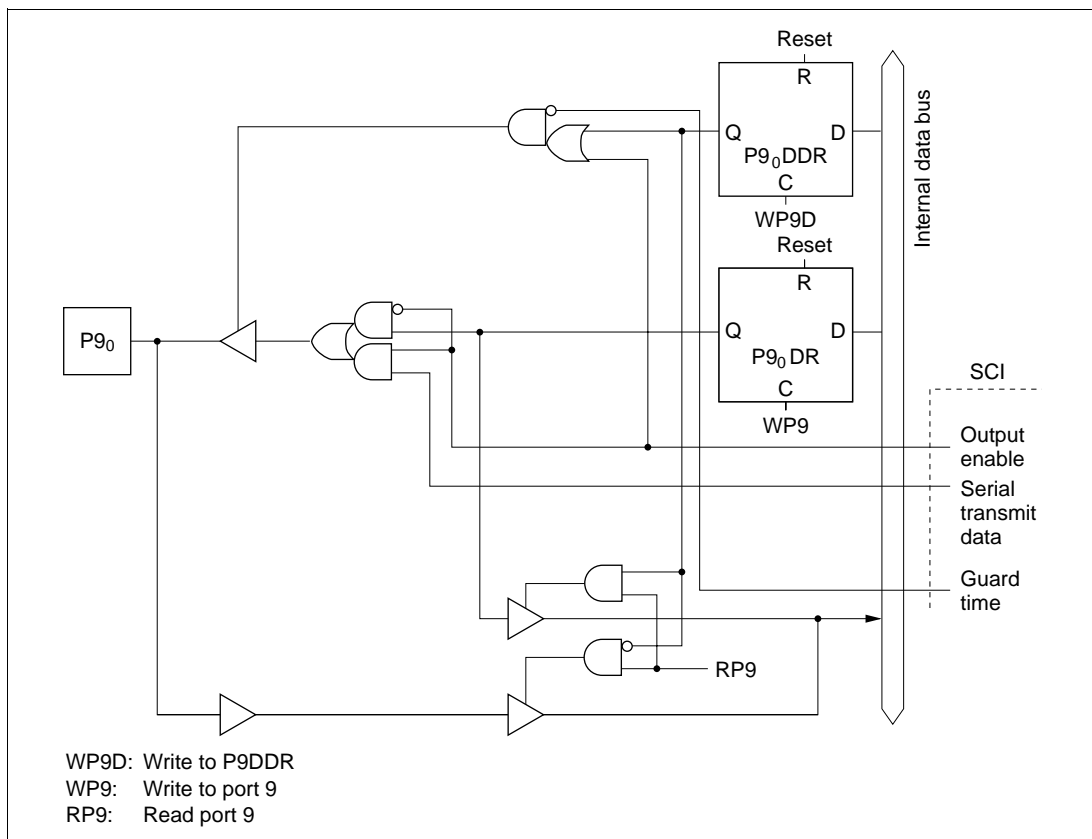
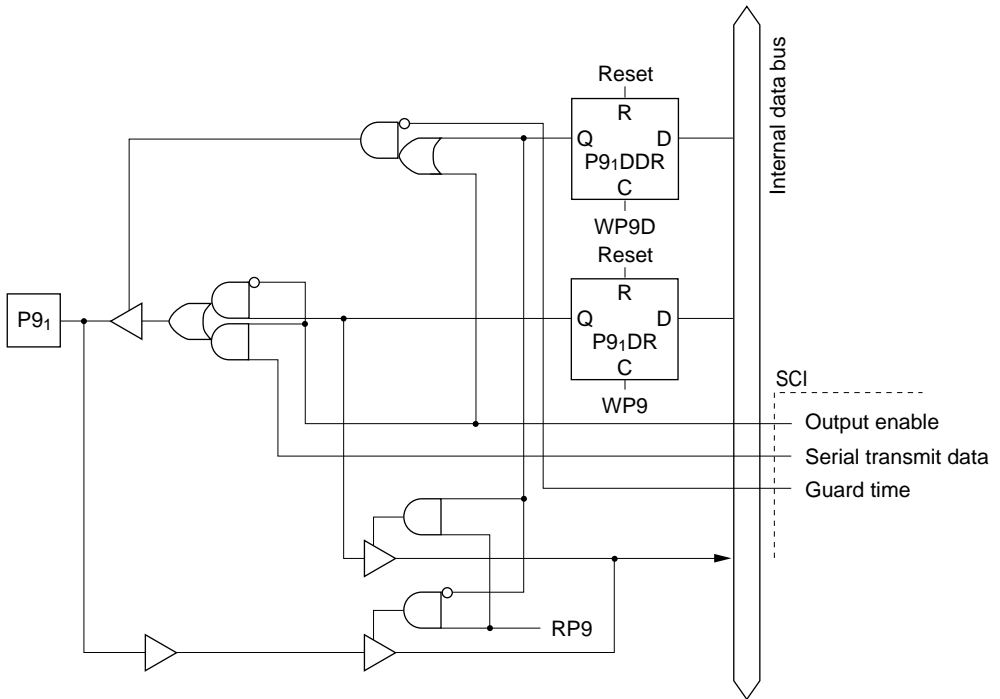

Figure C.5 (a) Port 9 Block Diagram (Pin P9₀)



WP9D: Write to P9DDR
 WP9: Write to port 9
 RP9: Read port 9

Figure C.5 (b) Port 9 Block Diagram (Pin P9₁)

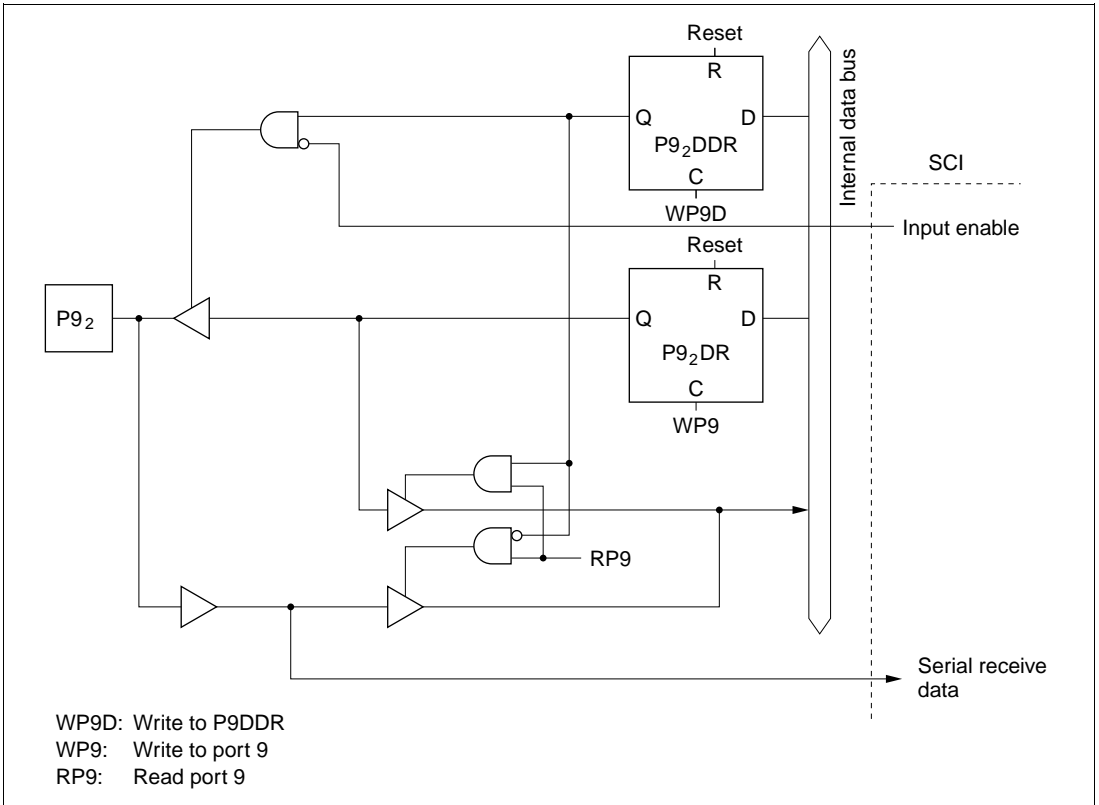

Figure C.5 (c) Port 9 Block Diagram (Pin P9₂)

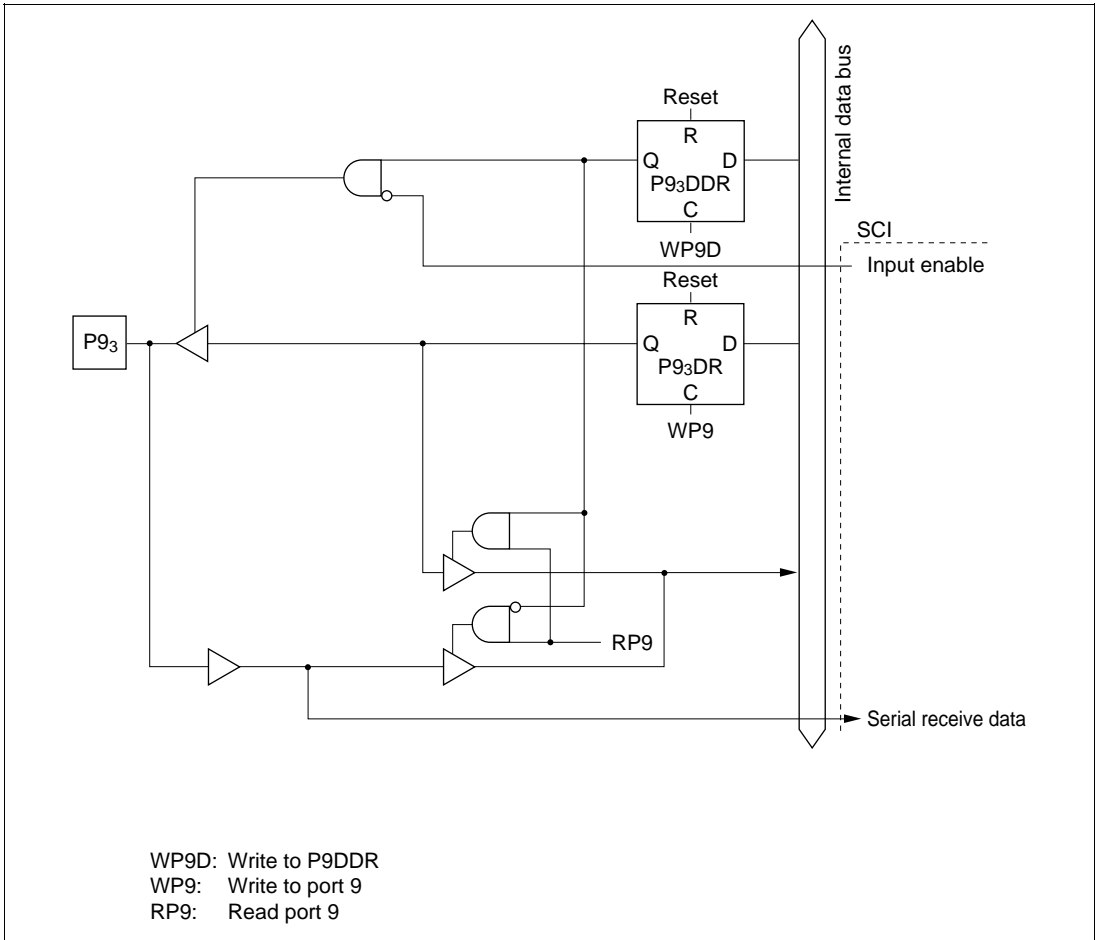

Figure C.5 (d) Port 9 Block Diagram (Pin P9₃)

C.6 Port A Block Diagrams

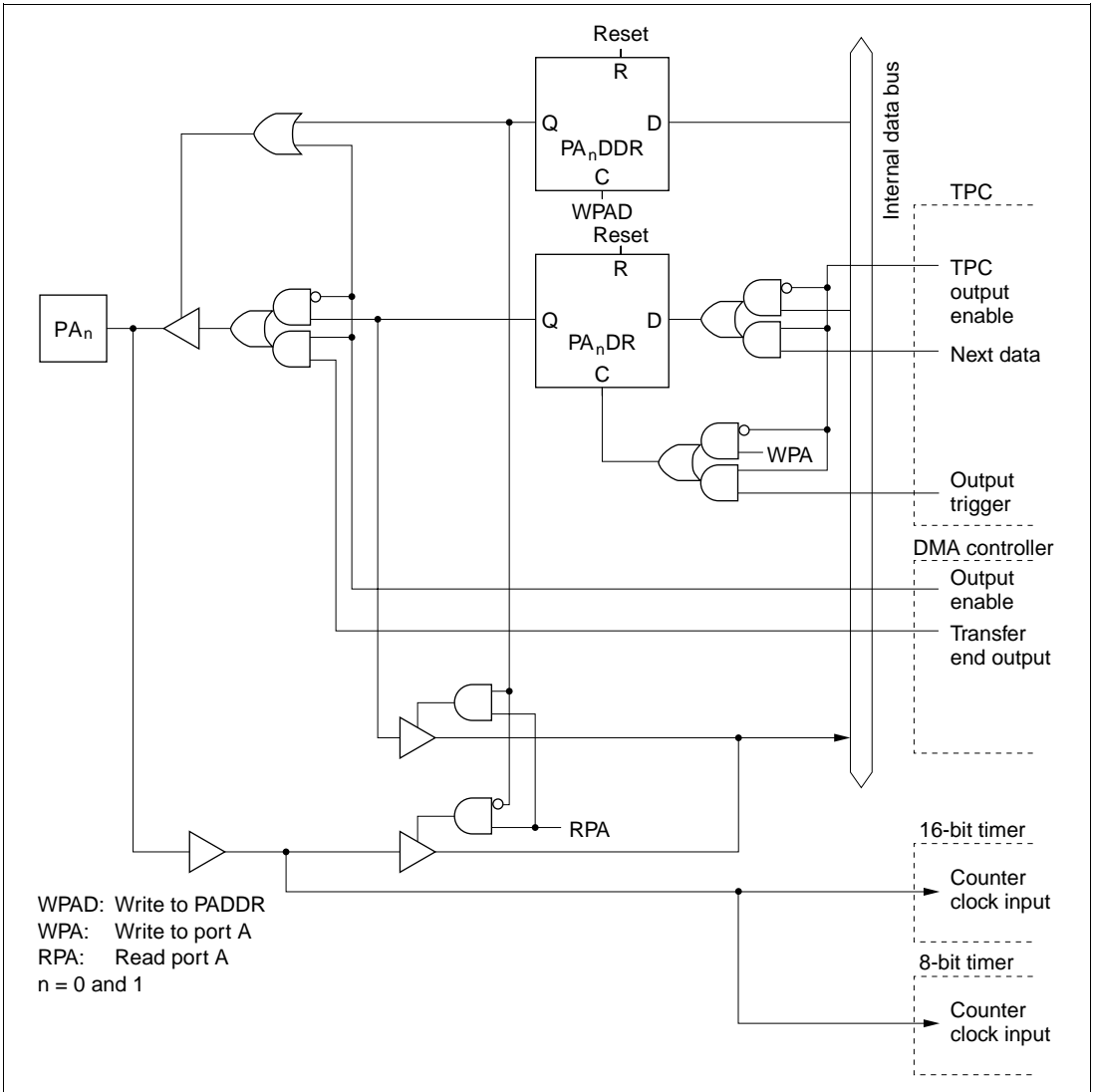

Figure C.6 (a) Port A Block Diagram (Pins PA_0 , PA_1)

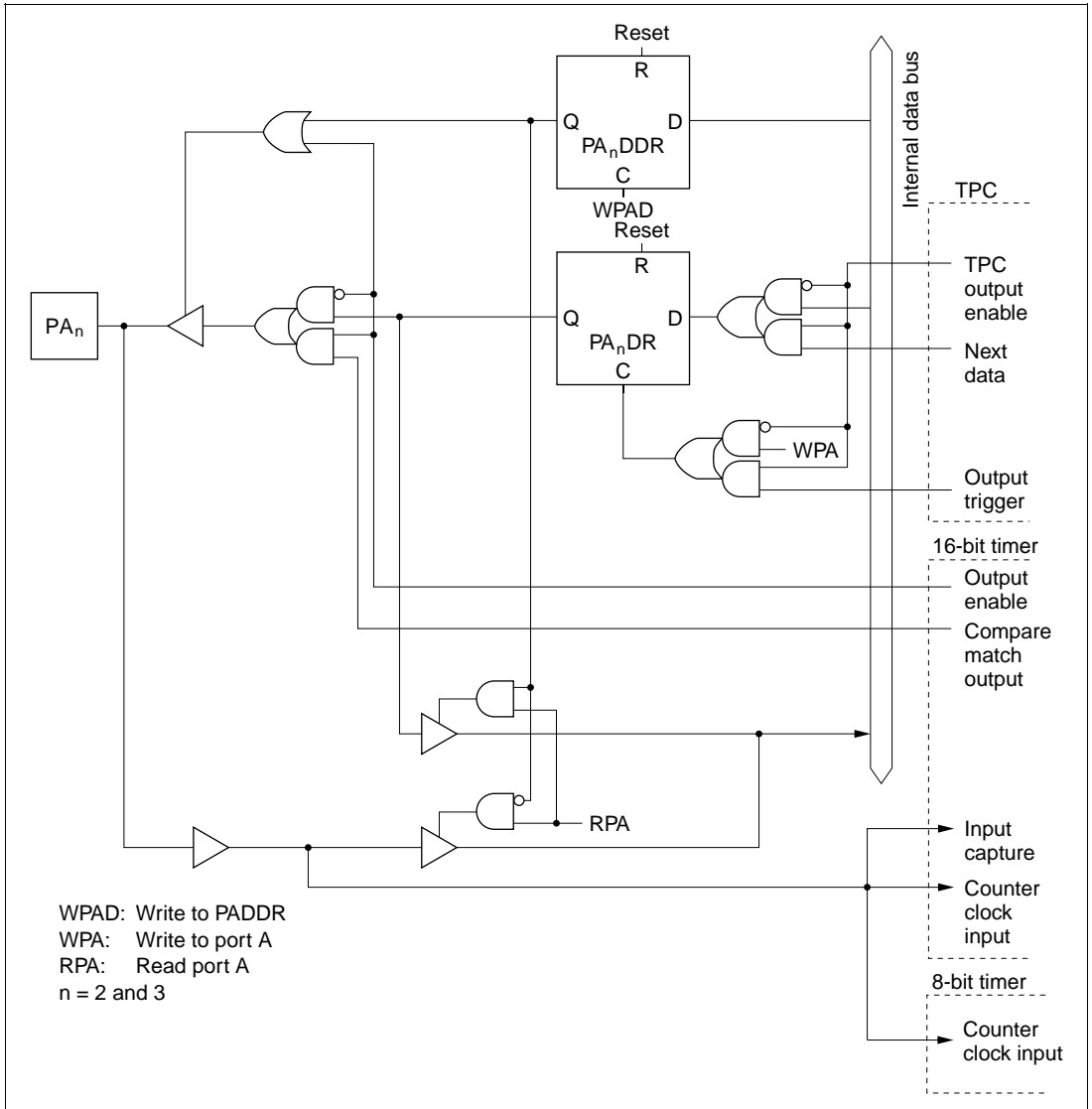

Figure C.6 (b) Port A Block Diagram (Pins PA₂, PA₃)

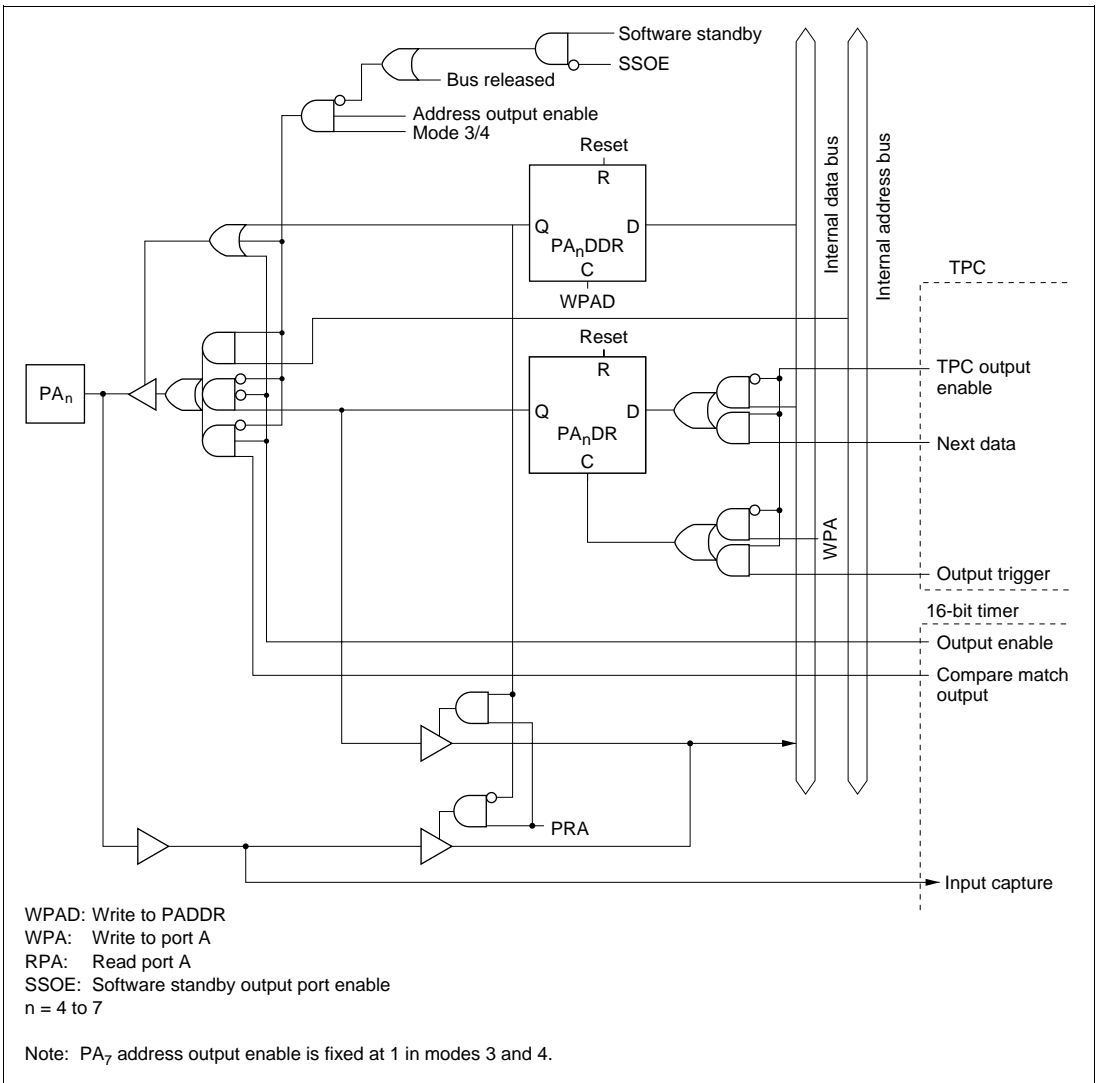

Figure C.6 (c) Port A Block Diagram (Pins PA₄ to PA₇)

C.7 Port B Block Diagrams

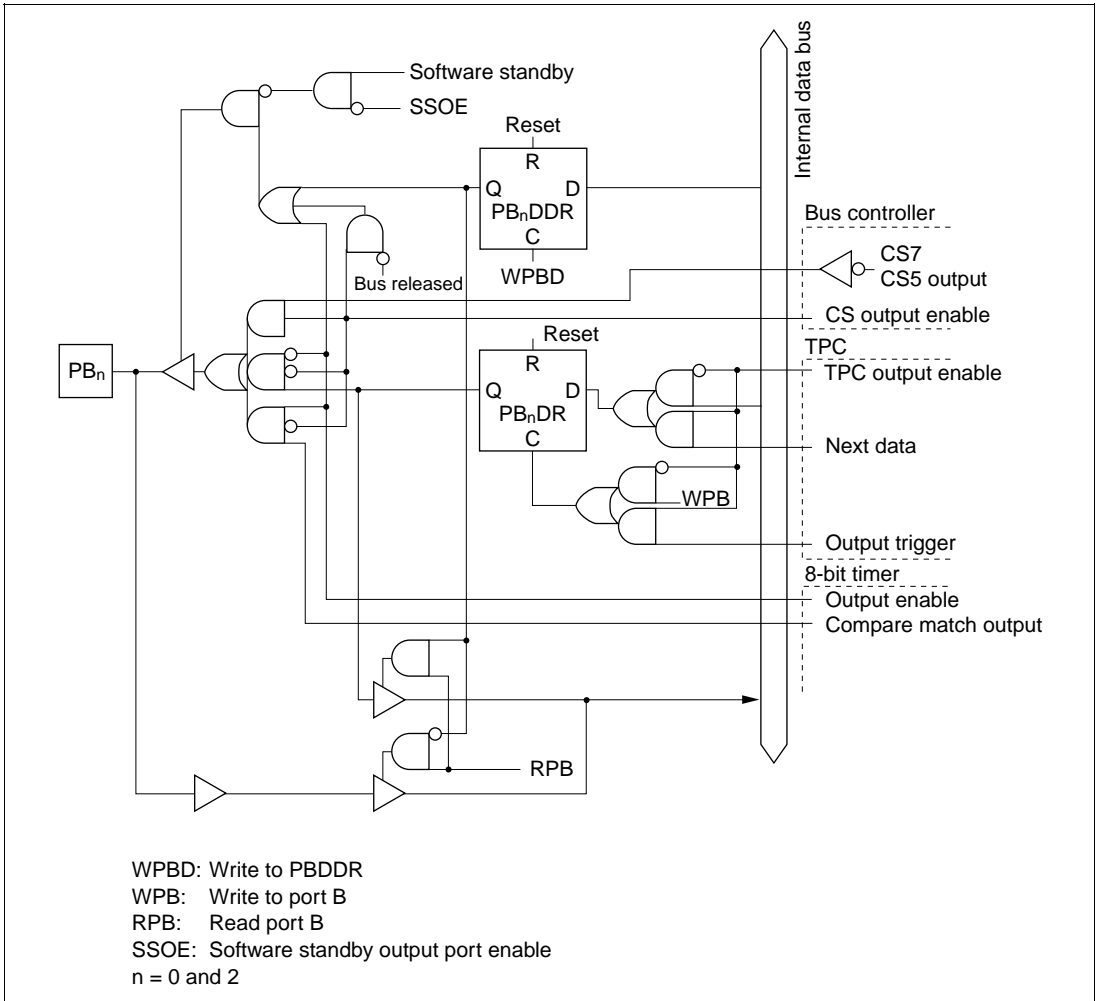

Figure C.7 (a) Port B Block Diagram (Pins PB_0 , PB_2)

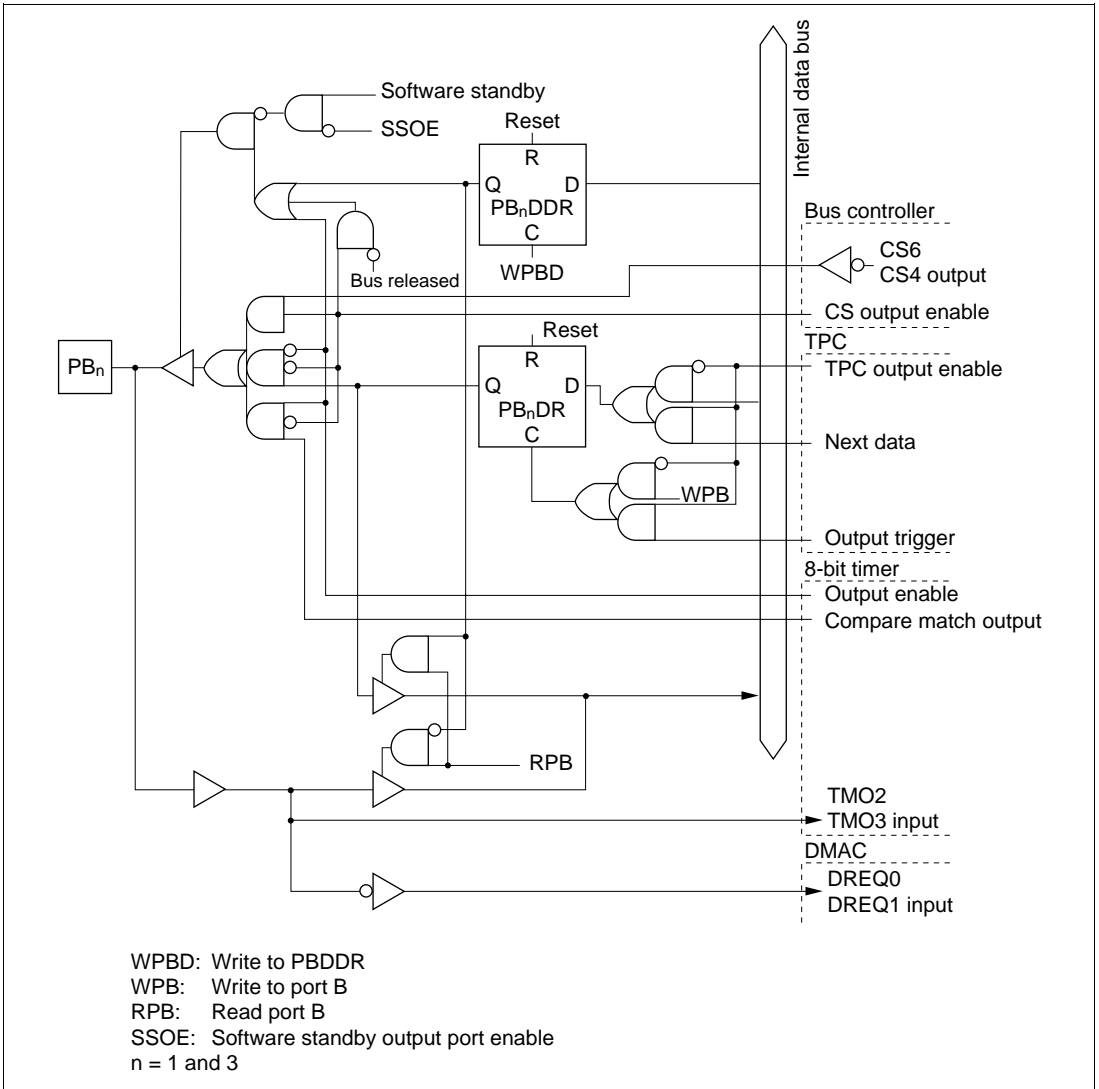

Figure C.7 (b) Port B Block Diagram (Pins PB_1 , PB_3)

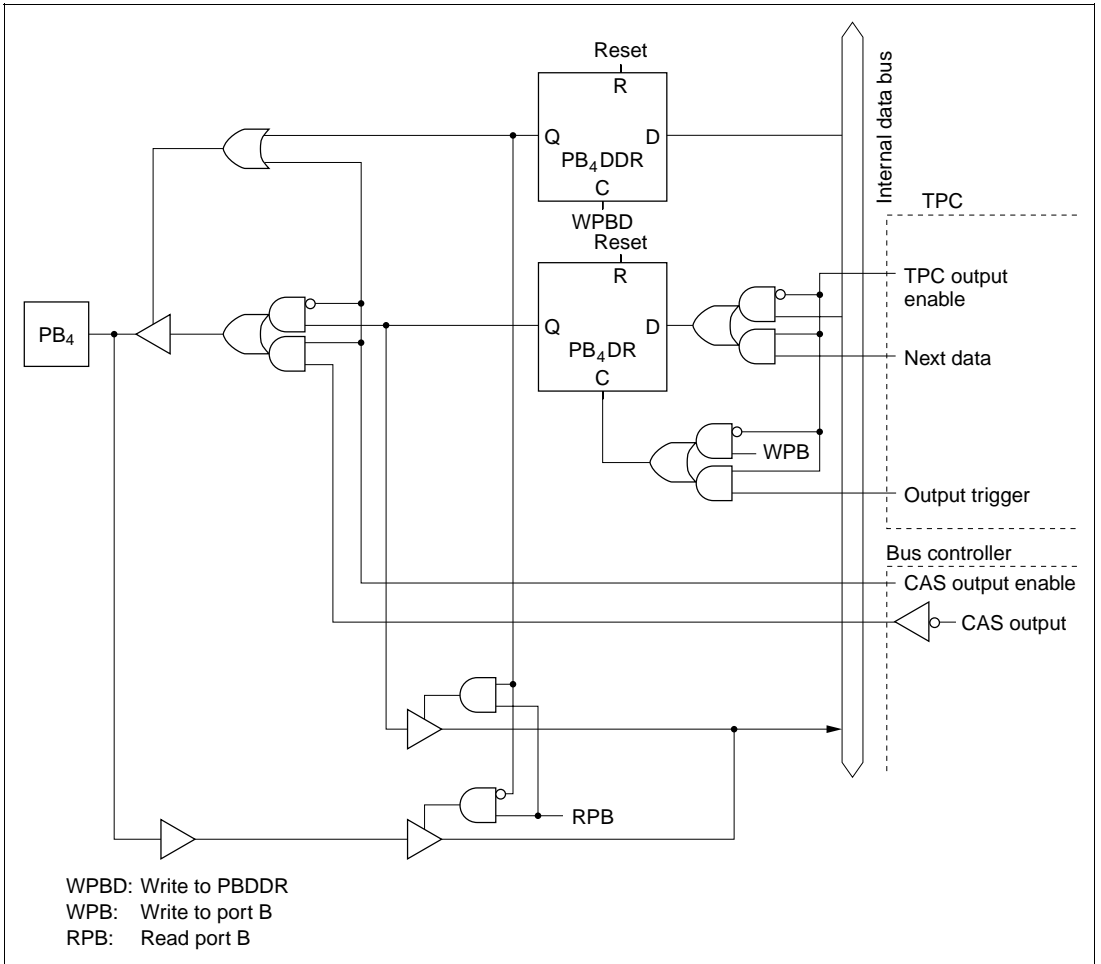
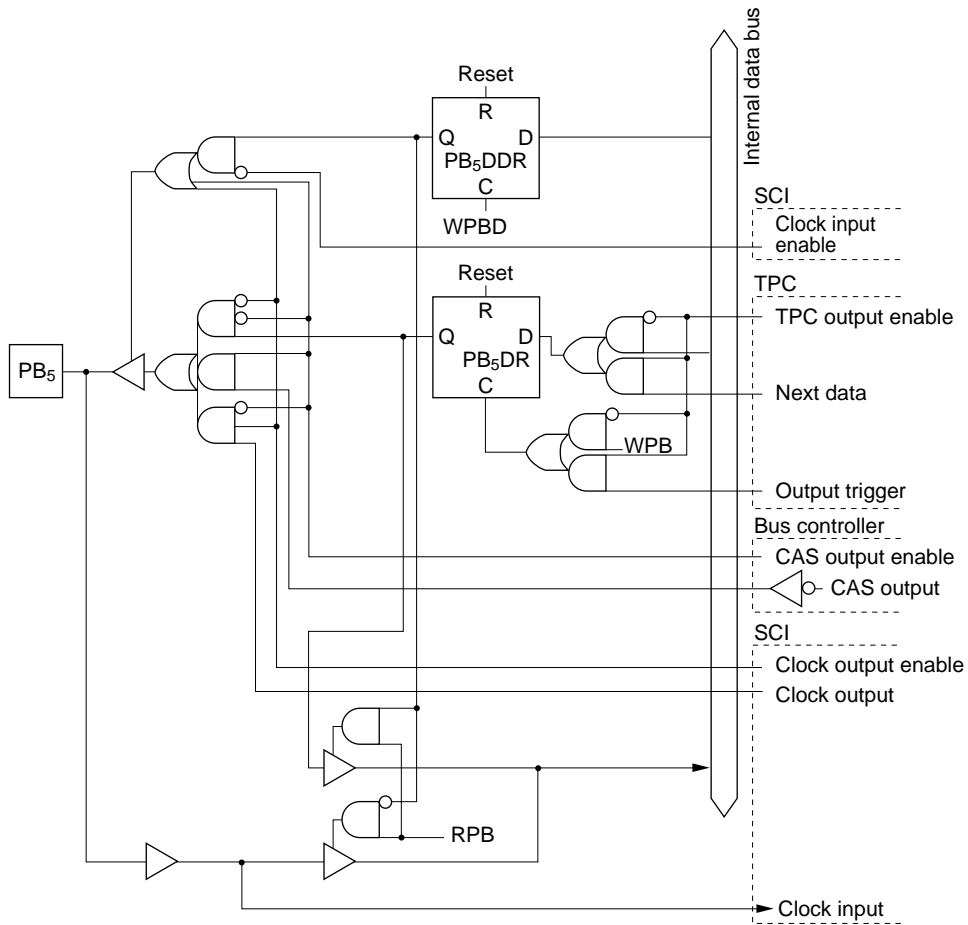

Figure C.7 (c) Port B Block Diagram (Pin PB₄)



WPBD: Write to PBDDR
 WPB: Write to port B
 RPB: Read port B

Figure C.7 (d) Port B Block Diagram (Pin PB₅)

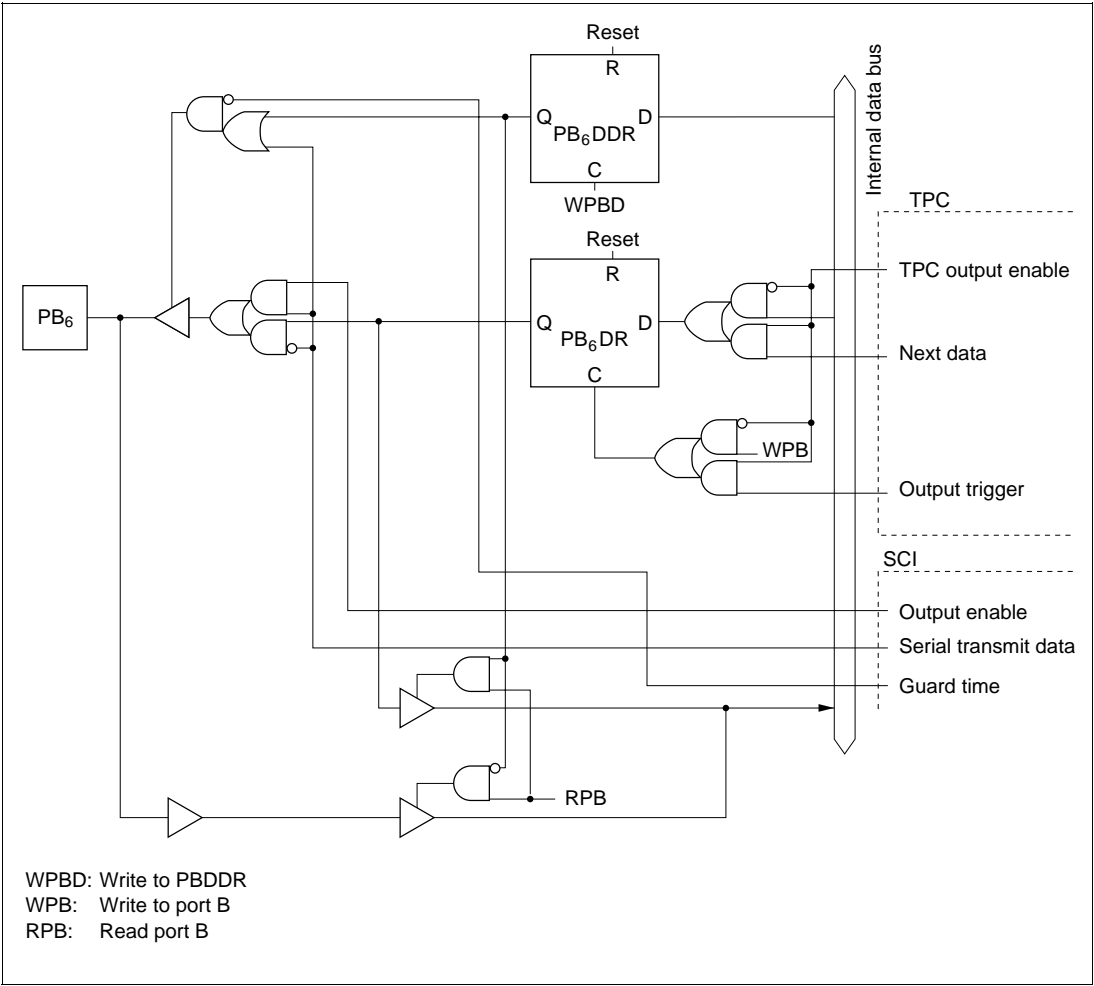

Figure C.7 (e) Port B Block Diagram (Pin PB₆)

Appendix D Pin States

D.1 Port States in Each Mode

Table D.1 Port States in Each Processing State

Port Name Pin Name	Mode	Reset	Hardware Standby Mode	Software Standby Mode	Bus-Released State	Program Execution State
$\overline{\text{RESO}}$	—	T*1	T	T	T*1	T*1
A ₁₉ to A ₀	1 to 4	L	T	[SSOE = 0] T [SSOE = 1] Keep	T	A ₁₉ to A ₀
D ₁₅ to D ₈	1 to 4	T	T	T	T	D ₁₅ to D ₈
$\overline{\text{AS}}, \overline{\text{RD}}, \overline{\text{HWR}}, \overline{\text{LWR}}$	1 to 4	H	T	[SSOE = 0] T [SSOE = 1] H	T	$\overline{\text{AS}}, \overline{\text{RD}}, \overline{\text{HWR}}, \overline{\text{LWR}}$
P ₄₇ to P ₄₀	1, 3	T	T	Keep	Keep	I/O port
	2, 4	T	T	T	T	D ₇ to D ₀
P ₆₀	1 to 4	T	T	Keep	Keep	I/O port WAIT
P ₆₁	1 to 4	T	T	[BRLE = 0] Keep [BRLE = 1] T	T	I/O port BREQ
P ₆₂	1 to 4	T	T	[BRLE = 0] Keep	L	[BRLE = 0] I/O port
				[BRLE = 1] H		[BRLE = 1] BACK
P ₆₇	1 to 4	Clock output	T	[PSTOP = 0] H	[PSTOP = 0] φ	[PSTOP = 0] φ
				[PSTOP = 1] Keep	[PSTOP = 1] Keep	[PSTOP = 1] Input port
P ₇₇ to P ₇₀	1 to 4	T	T	T	T	Input port

Port Name			Hardware Standby			Program Execution
Pin Name	Mode	Reset	Mode	Software Standby Mode	Bus-Released State	State
P8 ₀	1 to 4	T	T	<ul style="list-style-type: none"> When DRAM space is not selected*² [RFSHE = 0] Keep [RFSHE = 1] Illegal setting When DRAM space is selected*³ [RFSHE = 0] Keep [RFSHE = 1, SRFMD = 0, SSOE = 0] T [RFSHE = 1, SRFMD = 0, SSOE = 1] H [RFSHE = 1, SRFMD = 1] RFSH 	<ul style="list-style-type: none"> When DRAM space is not selected*² [RFSHE = 0] Keep [RFSHE = 1] Illegal setting When DRAM space is selected*³ [RFSHE = 0] Keep [RFSHE = 1] T 	[RFSHE = 0] I/O port [RFSHE = 1] RFSH
P8 ₁	1 to 4	T	T	<ul style="list-style-type: none"> RAS₃ output*⁴ [SSOE = 0] T [SSOE = 1] H Otherwise*⁵ [DDR = 0] T [DDR = 1, SSOE = 0] T [DDR = 1, SSOE = 1] H 	<ul style="list-style-type: none"> RAS₃ output*⁴ T Otherwise*⁵ [DDR = 0] Keep [DDR = 1] T 	<ul style="list-style-type: none"> RAS₃ output $\overline{\text{RAS}}_3$ Otherwise [DDR = 0] Input port [DDR = 1] $\overline{\text{CS}}_3$

Port Name Pin Name	Mode	Reset	Hardware Standby Mode	Software Standby Mode	Bus-Released State	Program Execution State
P8 ₂	1 to 4	T	T	<ul style="list-style-type: none"> • RAS₂ output*³ [SSOE = 0] T • [SSOE = 1] H • Otherwise*² [DDR = 0] T [DDR = 1, SSOE = 0] T [DDR = 1, SSOE = 1] H 	<ul style="list-style-type: none"> • RAS₂ output*³ T • Otherwise*² [DDR = 0] Keep [DDR = 1] T 	<ul style="list-style-type: none"> • RAS₂ output $\overline{\text{RAS}}_2$ • Otherwise [DDR = 0] Input port [DDR = 1] $\overline{\text{CS}}_2$
P8 ₃	1 to 4	T	T	<ul style="list-style-type: none"> • [DDR = 0] T • [DDR = 1, SSOE = 0] T • [DDR = 1, SSOE = 1] H 	<ul style="list-style-type: none"> • [DDR = 0] Keep • [DDR = 1] T 	<ul style="list-style-type: none"> • [DDR = 0] Input port • [DDR = 1] $\overline{\text{CS}}_1$
P8 ₄	1 to 4	H	T	<ul style="list-style-type: none"> • [DDR = 0] T • [DDR = 1, SSOE = 0] T • [DDR = 1, SSOE = 1] H 	<ul style="list-style-type: none"> • [DDR = 0] Keep • [DDR = 1] T 	<ul style="list-style-type: none"> • [DDR = 0] Input port • [DDR = 1] $\overline{\text{CS}}_0$
P9 ₅ to P9 ₀	1 to 4	T	T	Keep	Keep	I/O port
PA ₃ to PA ₀	1 to 4	T	T	Keep	Keep	I/O port
PA ₆ to PA ₄	1, 2	T	T	Keep	Keep	I/O port
	3, 4	T	T	<ul style="list-style-type: none"> • Address output*⁶ [SSOE = 0] T • [SSOE = 1] Keep • Otherwise*⁷ Keep 	<ul style="list-style-type: none"> • Address output*⁶ T • Otherwise*⁷ Keep 	<ul style="list-style-type: none"> • Address output A₂₃ to A₂₁ • Otherwise I/O port

Port Name Pin Name	Mode	Reset	Hardware Standby Mode	Software Standby Mode	Bus-Released State	Program Execution State
PA ₇	1, 2	T	T	Keep	Keep	I/O port
	3, 4	L	T	[SSOE = 0] T [SSOE = 1] Keep	T	A ₂₀
PB ₁ , PB ₀	1 to 4	T	T	<ul style="list-style-type: none"> • CS output*⁸ [SSOE = 0] T [SSOE = 1] H • Otherwise*⁹ Keep 	<ul style="list-style-type: none"> • CS output*⁸ T • Otherwise*⁹ Keep 	<ul style="list-style-type: none"> • CS output $\overline{CS}_7, \overline{CS}_6$ • Otherwise I/O port
PB ₂	1 to 4	T	T	<ul style="list-style-type: none"> • RAS₅ output*¹⁰ [SSOE = 0] T [SSOE = 1] H • CS output*¹¹ [SSOE = 0] T [SSOE = 1] H • Otherwise*¹² Keep 	<ul style="list-style-type: none"> • RAS₅ output*¹⁰ T • CS output *¹¹ T • Otherwise*¹² Keep 	<ul style="list-style-type: none"> • RAS₅ output RAS₅ • CS output \overline{CS}_5 • Otherwise I/O port
PB ₃	1 to 4	T	T	<ul style="list-style-type: none"> • RAS₄ output*¹³ [SSOE = 0] T [SSOE = 1] H • CS output*¹⁴ [SSOE = 0] T [SSOE = 1] H • Otherwise*¹⁵ Keep 	<ul style="list-style-type: none"> • RAS₄ output*¹³ T • CS output *¹⁴ T • Otherwise*¹⁵ Keep 	<ul style="list-style-type: none"> • RAS₄ output \overline{RAS}_4 • CS output \overline{CS}_4 • Otherwise I/O port

Port Name	Hardware Standby			Software Standby Mode	Bus-Released State	Program Execution State
Pin Name	Mode	Reset	Mode			
PB ₅ , PB ₄	1 to 4	T	T	<ul style="list-style-type: none"> CAS output*¹⁶ [SSOE = 0] T [SSOE = 1] H Otherwise*¹⁷ Keep 	<ul style="list-style-type: none"> CAS output*¹⁶ T Otherwise*¹⁷ Keep 	<ul style="list-style-type: none"> CAS output <u>UCAS</u>, <u>LCAS</u> Otherwise I/O port
PB ₇ , PB ₆	1 to 4	T	T	Keep	Keep	I/O port

Legend

H: High

L: Low

T: High-impedance state

Keep: Input pins are in the high-impedance state; output pins maintain their previous state.

DDR: Data direction register

- Notes:
- Low only when WDT overflow causes a reset.
 - When bits DRAS2, DRAS1, and DRAS0 in DRCRA (DRAM control register A) are all cleared to 0.
 - When any of bits DRAS2, DRAS1, or DRAS0 in DRCRA (DRAM control register A) is set to 1.
 - When the setting of bits DRAS2, DRAS1, and DRAS0 in DRCRA (DRAM control register A) is 010, 100, or 101.
 - When the setting of bits DRAS2, DRAS1, and DRAS0 in DRCRA (DRAM control register A) is other than 010, 100, or 101.
 - When bit A23E, A22E, or A21E, respectively, in BRCCR (bus release control register) is cleared to 0.
 - When bit A23E, A22E, or A21E, respectively, in BRCCR (bus release control register) is set to 1.
 - When bit CS7E or CS6E, respectively, in CSCR (chip select control register) is set to 1.
 - When bit CS7E or CS6E, respectively, in CSCR (chip select control register) is cleared to 0.
 - When the setting of bits DRAS2, DRAS1, and DRAS0 in DRCRA (DRAM control register A) is 101.
 - When the setting of bits DRAS2, DRAS1, and DRAS0 in DRCRA (DRAM control register A) is other than 101, and bit CS5E in CSCR (chip select control register) is set to 1.
 - When the setting of bits DRAS2, DRAS1, and DRAS0 in DRCRA (DRAM control register A) is other than 101, and bit CS5E in CSCR (chip select control register) is cleared to 0.
 - When the setting of bits DRAS2, DRAS1, and DRAS0 in DRCRA (DRAM control register A) is 100, 101, or 110.

14. When the setting of bits DRAS2, DRAS1, and DRAS0 in DRCRA (DRAM control register A) is other than 100, 101, or 110, and bit CS4E in CSCR (chip select control register) is set to 1.
15. When the setting of bits DRAS2, DRAS1, and DRAS0 in DRCRA (DRAM control register A) is other than 100, 101, or 110, and bit CS4E in CSCR (chip select control register) is cleared to 0.
16. When any of bits DRAS2, DRAS1, or DRAS0 in DRCRA (DRAM control register A) is set to 1, and bit CSEL in DRCRB (DRAM control register B) is cleared to 0.
17. When any of bits DRAS2, DRAS1, or DRAS0 in DRCRA (DRAM control register A) is set to 1, and bit CSEL in DRCRB (DRAM control register B) is set to 1; or, when bits DRAS2, DRAS1, and DRAS0 are cleared to 0.

D.2 Pin States at Reset

Modes 1 and 2: Figure D.1 is a timing diagram for the case in which $\overline{\text{RES}}$ goes low during an external memory access in mode 1 or 2. As soon as $\overline{\text{RES}}$ goes low, all ports are initialized to the input state. $\overline{\text{AS}}$, $\overline{\text{RD}}$, $\overline{\text{HWR}}$, $\overline{\text{LWR}}$, and $\overline{\text{CS}}_0$ go high, and D_{15} to D_0 go to the high-impedance state. The address bus is initialized to the low output level 2.5 ϕ clock cycles after the low level of $\overline{\text{RES}}$ is sampled. Clock pin $\text{P6}_7/\phi$ goes to the output state at the next rise of ϕ after $\overline{\text{RES}}$ goes low.

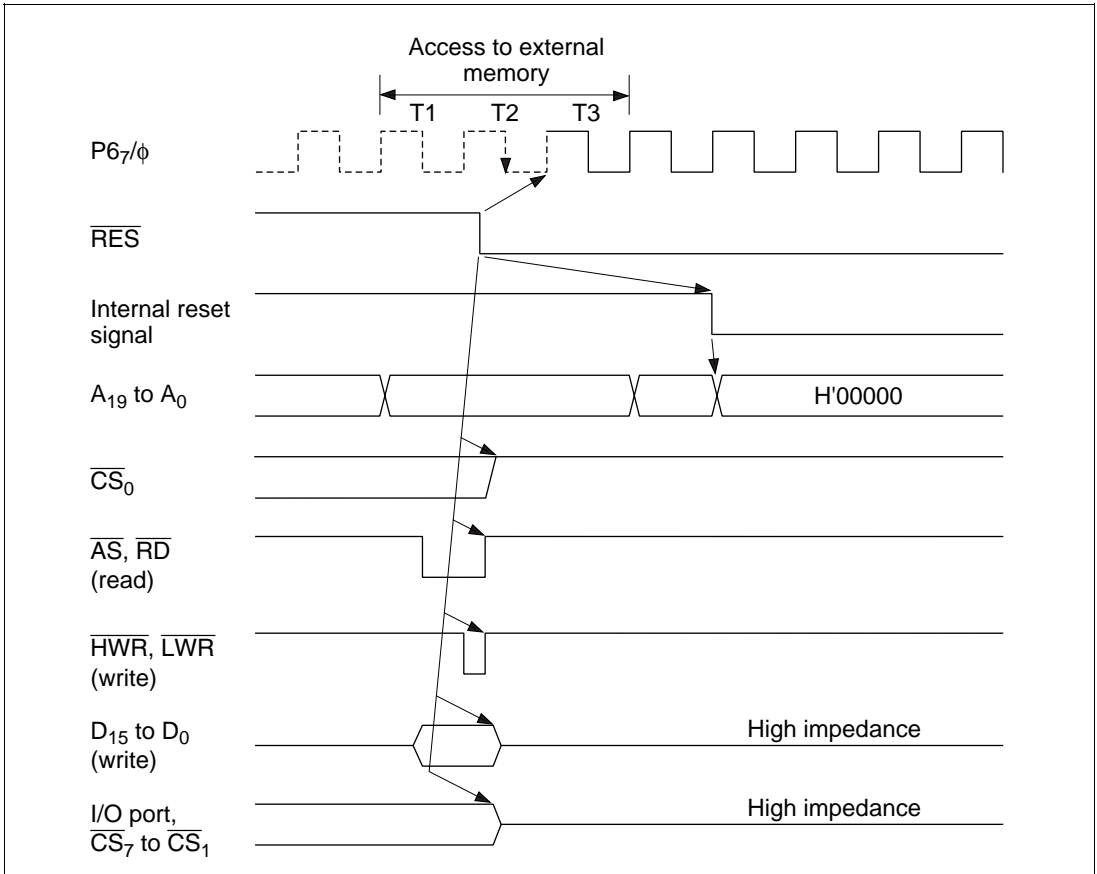

Figure D.1 Reset during Memory Access (Modes 1 and 2)

Modes 3 and 4: Figure D.2 is a timing diagram for the case in which $\overline{\text{RES}}$ goes low during an external memory access in mode 3 or 4. As soon as $\overline{\text{RES}}$ goes low, all ports are initialized to the input state. $\overline{\text{AS}}$, $\overline{\text{RD}}$, $\overline{\text{HWR}}$, $\overline{\text{LWR}}$, and $\overline{\text{CS}}_0$ go high, and D_{15} to D_0 go to the high-impedance state. The address bus is initialized to the low output level 2.5 ϕ clock cycles after the low level of $\overline{\text{RES}}$ is sampled. However, when PA_4 to PA_6 are used as address bus pins, or when P8_3 to P8_1 and PB_0 to PB_3 are used as CS output pins, they go to the high-impedance state at the same time as $\overline{\text{RES}}$ goes low. Clock pin $\text{P6}_7/\phi$ goes to the output state at the next rise of ϕ after $\overline{\text{RES}}$ goes low.

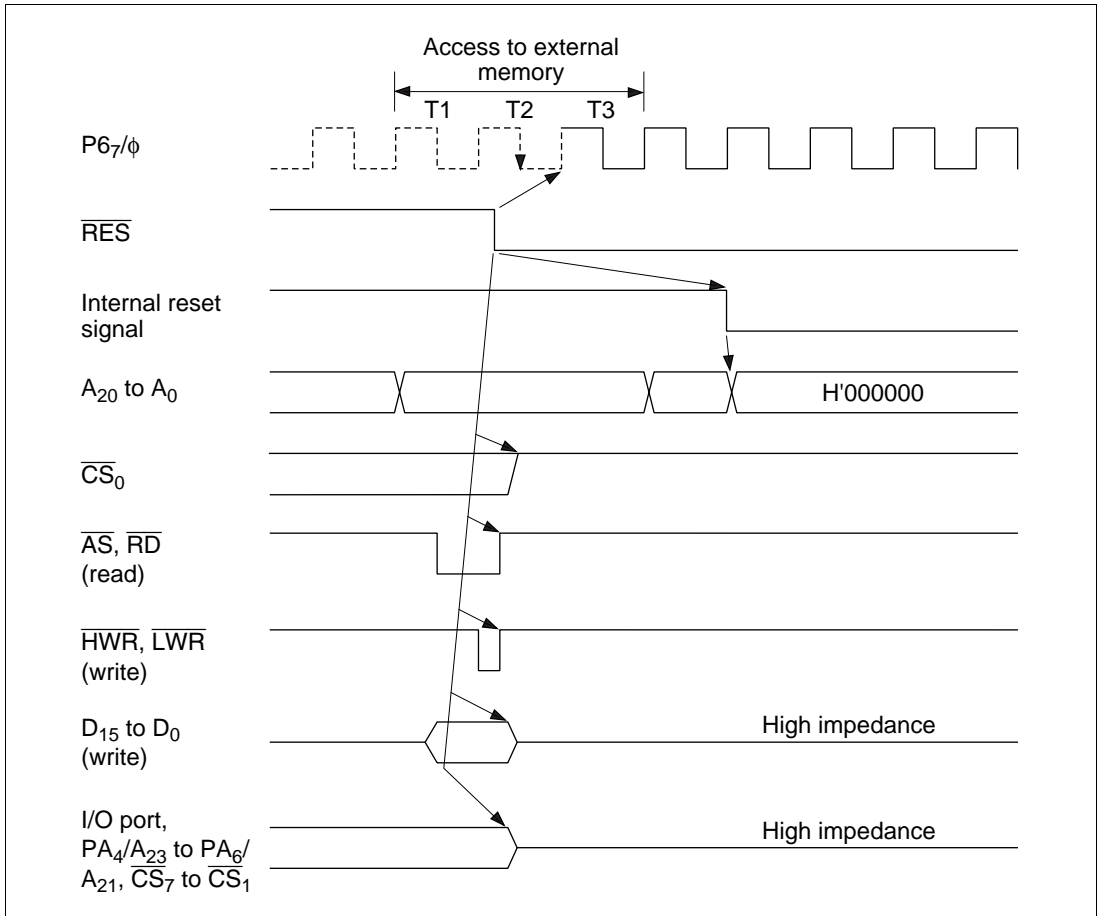
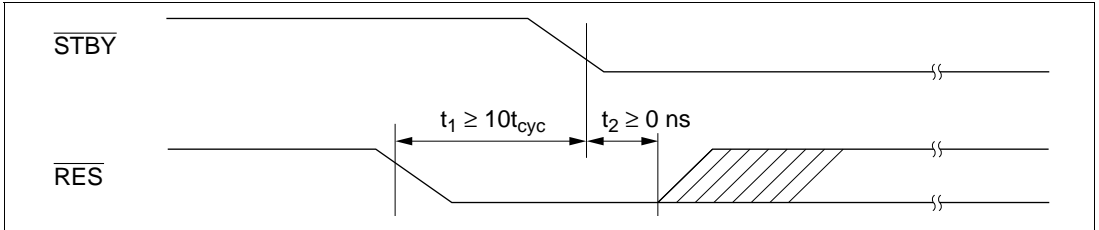

Figure D.2 Reset during Memory Access (Modes 3 and 4)

Appendix E Timing of Transition to and Recovery from Hardware Standby Mode

Timing of Transition to Hardware Standby Mode

- (1) To retain RAM contents with the RAME bit set to 1 in SYSCR, drive the $\overline{\text{RES}}$ signal low 10 system clock cycles before the $\overline{\text{STBY}}$ signal goes low, as shown below. $\overline{\text{RES}}$ must remain low until $\overline{\text{STBY}}$ goes low (minimum delay from $\overline{\text{STBY}}$ low to $\overline{\text{RES}}$ high: 0 ns).



- (2) To retain RAM contents with the RAME bit cleared to 0 in SYSCR, or when RAM contents do not need to be retained, $\overline{\text{RES}}$ does not have to be driven low as in (1).

Timing of Recovery from Hardware Standby Mode: Drive the $\overline{\text{RES}}$ signal low approximately 100 ns before $\overline{\text{STBY}}$ goes high.

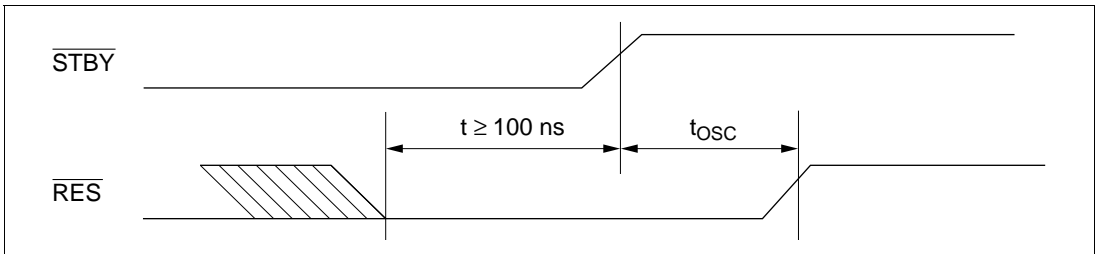

Appendix F List of Product Codes

Table F.1 H8/3007, H8/3006 Product Code Lineup

Product Type	Product Code	Mark Code	Package (Hitachi Package Code)
H8/3007 5.0 V ± 10% (5 V)	HD6413007F	HD6413007F	100-pin QFP (FP-100B)
	HD6413007TE	HD6413007TE	100-pin TQFP (TFP-100B)
	HD6413007FP	HD6413007FP	100-pin QFP (FP-100A)
2.7 to 5.5 V (Low voltage)	HD6413007VF	HD6413007VF	100-pin QFP (FP-100B)
	HD6413007VTE	HD6413007VTE	100-pin TQFP (TFP-100B)
	HD6413007VFP	HD6413007VFP	100-pin QFP (FP-100A)
H8/3006 5.0 V ± 10% (5 V)	HD6413006F	HD6413006F	100-pin QFP (FP-100B)
	HD6413006TE	HD6413006TE	100-pin TQFP (TFP-100B)
	HD6413006FP	HD6413006FP	100-pin QFP (FP-100A)
2.7 to 5.5 V (Low voltage)	HD6413006VF	HD6413006VF	100-pin QFP (FP-100B)
	HD6413006VTE	HD6413006VTE	100-pin TQFP (TFP-100B)
	HD6413006VFP	HD6413006VFP	100-pin QFP (FP-100A)

Appendix G Package Dimensions

Figure G.1 shows the FP-100B package dimensions of the H8/3006 and H8/3007. Figure G.2 shows the TFP-100B package dimensions. Figure G.3 shows the FP-100A package dimensions.

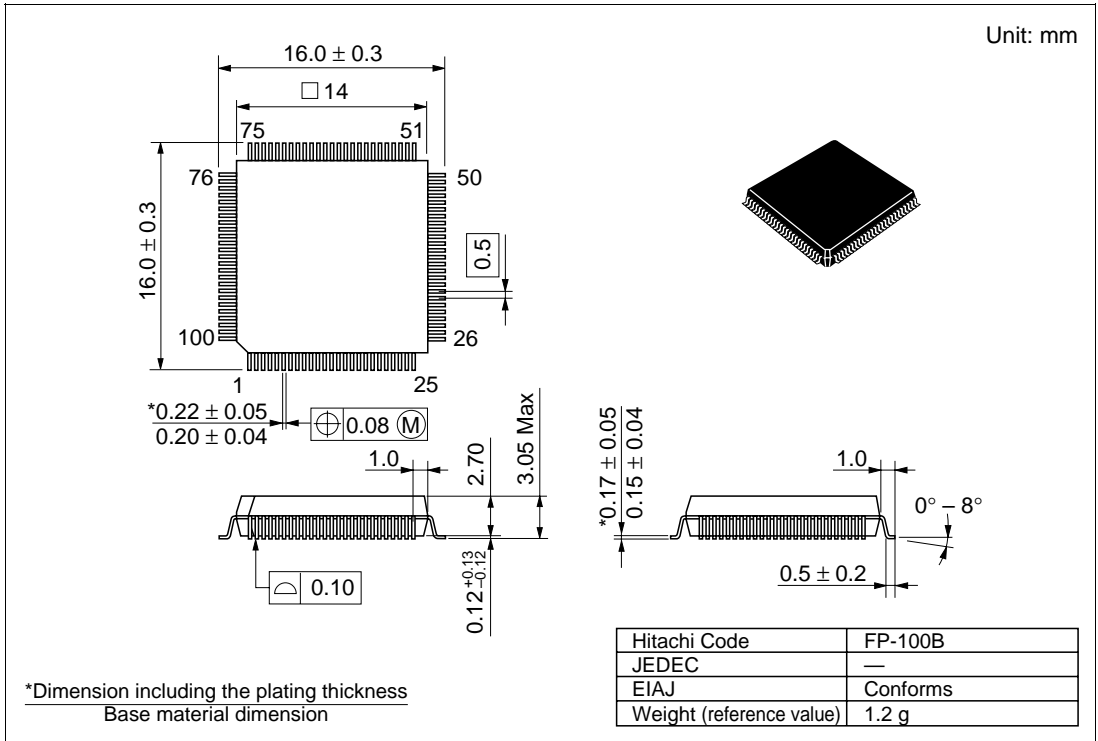
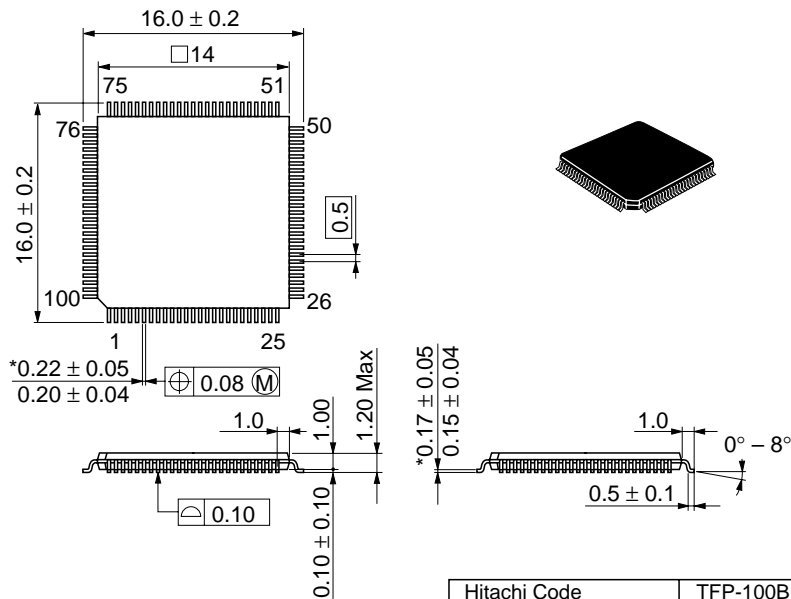

Figure G.1 Package Dimensions (FP-100B)



*Dimension including the plating thickness
Base material dimension

Hitachi Code	TFP-100B
JEDEC	—
EIAJ	Conforms
Weight (reference value)	0.5 g

Figure G.2 Package Dimensions (TFP-100B)

Unit: mm

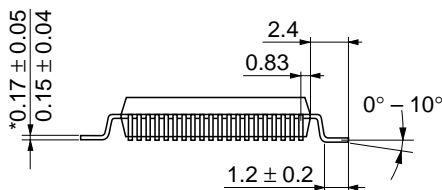
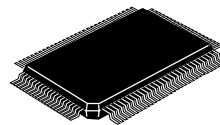
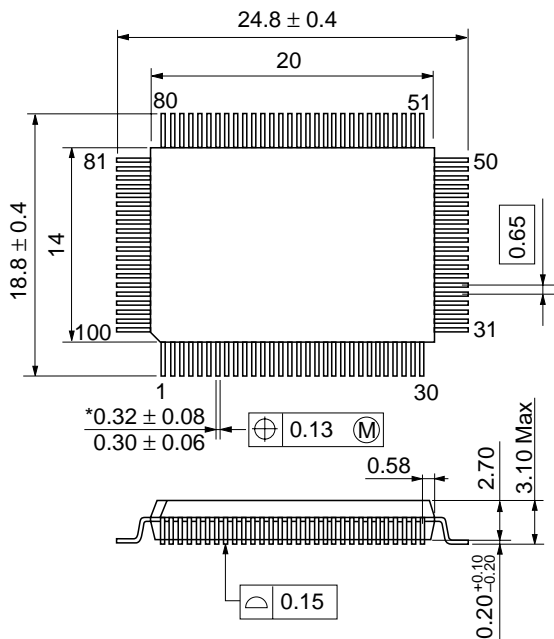

Hitachi Code	FP-100A
JEDEC	—
EIAJ	—
Weight (reference value)	1.7 g

*Dimension including the plating thickness
Base material dimension

Figure G.3 Package Dimensions (FP-100A)

Appendix H Comparison of H8/300H Series Product Specifications

H.1 Differences between H8/3067 and H8/3062 Series, H8/3048 Series, H8/3006 and H8/3007, and H8/3002

Item		H8/3067, H8/3062 Series	H8/3048 Series	H8/3006, H8/3007	H8/3002
1	Operating mode	Mode 5 16 MB ROM enabled expanded mode	1 MB ROM enabled expanded mode		
		Mode 6 64 KB single-chip mode	16 MB ROM enabled expanded mode		
2	Interrupt controller	Internal interrupt sources 36 (H8/3067) 27 (H8/3062)	30	36	30
3	Bus controller	Burst ROM interface Yes (H8/3067) No (H8/3062)	No	Yes	No
		Idle cycle insertion function	Yes	No	Yes
	Wait mode	2 modes	4 modes	2 modes	4 modes
	Wait state number setting	Per area	Common to all areas	Per area	Common to all areas
	Address output method	Choice of address update mode (mask ROM and flash memory R versions only)	Fixed	Fixed	Fixed
4	DRAM interface	Connectable areas Area 2/3/4/5 (H8/3067 only)	Area 3	Area 2/3/4/5	Area 3
		Precharge cycle insertion function	Yes (H8/3067 only)	No	Yes
	Fast page mode	Yes (H8/3067 only)	No	Yes	No
	Address shift amount	8 bit/9 bit/10 bit (H8/3067 only)	8 bit/9 bit	8 bit/9 bit/10 bit	8 bit/9 bit

Item		H8/3067, H8/3062		H8/3048	H8/3006, H8/3007		H8/3002	
		Series		Series				
5	Timer functions	16-bit timers	8-bit timers	ITU	16-bit timers	8-bit timers	ITU	
		Number of channels	16 bits × 3	8 bits × 4 (16 bits × 2)	16 bits × 5	16 bits × 3	8 bits × 4 (16 bits × 2)	16 bits × 5
		Pulse output	6 pins	4 pins (2 pins)	12 pins	6 pins	4 pins (2 pins)	12 pins
		Input capture	6	2	10	6	2	10
		External clock	4 systems (selectable)	4 systems (fixed)	4 systems (selectable)	4 systems (selectable)	4 systems (fixed)	4 systems (selectable)
		Internal clock	φ, φ/2, φ/4, φ/8	φ/8, φ/64, φ/8192	φ, φ/2, φ/4, φ/8	φ, φ/2, φ/4, φ/8	φ/8, φ/64, φ/8192	φ, φ/2, φ/4, φ/8
		Complementary PWM function	No	No	Yes	No	No	Yes
		Reset-synchronous PWM function	No	No	Yes	No	No	Yes
		Buffer operation	No	No	Yes	No	No	Yes
		Output initialization function	Yes	No	No	Yes	No	No
		PWM output	3	4 (2)	5	3	4 (2)	5
		DMAC activation	3 channels (H8/3067 only)	No	4 channels	3 channels	No	4 channels
		A/D conversion activation	No	Yes	No	No	Yes	No
Interrupt sources	3 sources × 3	8 sources	3 sources × 5	3 sources × 3	8 sources	3 sources × 5		
6	TPC	Time base	3 kinds, 16-bit timer base	4 kinds, ITU base	3 kinds, 16-bit timer base		4 kinds, ITU base	
7	WDT	Reset signal external output function	Yes (except products with on-chip flash memory)	Yes	Yes		Yes	
8	SCI	Number of channels	3 channels (H8/3067) 2 channels (H8/3062)	2 channels	3 channels		2 channels	
		Smart card interface	Supported on all channels	Supported on SCI0 only	Supported on all channels		No	

Item		H8/3067, H8/3062 Series	H8/3048 Series	H8/3006, H8/3007	H8/3002	
9	A/D converter	Conversion start trigger input	External trigger/8-bit timer compare match	External trigger	External trigger/8-bit timer compare match	External trigger
10	Pin control	ϕ pin	ϕ /input port multiplexing	ϕ output only	ϕ /input port multiplexing	ϕ output only
		A_{20} in 16 MB ROM enabled expanded mode	A_{20} / I/O port multiplexing	A_{20} output		
		Address bus, \overline{AS} , \overline{RD} , \overline{HWR} , \overline{LWH} , \overline{CS}_7 to \overline{CS}_0 , \overline{RFSH} in software standby state	High-level output/high-impedance selectable (\overline{RFSH} : H8/3067 only)	High-level output (except \overline{CS}_0) Low-level output (\overline{CS}_0)	High-level output/high-impedance selectable	High-level output (except \overline{CS}_0) Low-level output (\overline{CS}_0)
		\overline{CS}_7 to \overline{CS}_0 in bus-released state	High-impedance	High-level output	High-impedance	High-level output
11	Flash memory functions	Program/erase voltage	12 V application unnecessary. Single-power-supply programming.	12 V application from off-chip		
		Block divisions	8 blocks	16 blocks		

H.2 Comparison of Pin Functions of 100-Pin Package Products (FP-100B, TFP-100B)

Table H.1 Pin Arrangement of Each Product (FP-100B, TFP-100B)

Pin No.	On-chip-ROM Products				ROMless Products	
	H8/3067 Series	H8/3062 Series	H8/3048 Series	H8/3042 Series	H8/3006, H8/3007	H8/3002
1	Vcc	Vcc	Vcc	Vcc	Vcc	Vcc
2	PB ₀ /TP ₈ /TMO ₀ / CS ₇	PB ₀ /TP ₈ /TMO ₀ / CS ₇	PB ₀ /TP ₈ / TIOCA3	PB ₀ /TP ₈ / TIOCA3	PB ₀ /TP ₈ /TMO ₀ / CS ₇	PB ₀ /TP ₈ / TIOCA3
3	PB ₁ /TP ₉ /TMIO ₁ / DREQ ₀ /CS ₆	PB ₁ /TP ₉ /TMIO ₁ / CS ₆	PB ₁ /TP ₉ / TIOCB3	PB ₁ /TP ₉ / TIOCB3	PB ₁ /TP ₉ /TMIO ₁ / DREQ ₀ /CS ₆	PB ₁ /TP ₉ / TIOCB3
4	PB ₂ /TP ₁₀ /TMO ₂ / CS ₅	PB ₂ /TP ₁₀ /TMO ₂ / CS ₅	PB ₂ /TP ₁₀ / TIOCA4	PB ₂ /TP ₁₀ / TIOCA4	PB ₂ /TP ₁₀ /TMO ₂ / CS ₅	PB ₂ /TP ₁₀ / TIOCA4
5	PB ₃ /TP ₁₁ / TMIO ₃ /DREQ ₁ / CS ₄	PB ₃ /TP ₁₁ / TMIO ₃ /CS ₄	PB ₃ /TP ₁₁ / TIOCB4	PB ₃ /TP ₁₁ / TIOC4	PB ₃ /TP ₁₁ / TMIO ₃ /DREQ ₁ / CS ₄	PB ₃ /TP ₁₁ / TIOCB4
6	PB ₄ /TP ₁₂ / UCAS	PB ₄ /TP ₁₂	PB ₄ /TP ₁₂ / TOCXA4	PB ₄ /TP ₁₂ / TOCXA4	PB ₄ /TP ₁₂ / UCAS	PB ₄ /TP ₁₂ / TOCXA4
7	PB ₅ /TP ₁₃ / LCAS/SCK ₂	PB ₅ /TP ₁₃	PB ₅ /TP ₁₃ / TOCXB4	PB ₅ /TP ₁₃ / TOCXB4	PB ₅ /TP ₁₃ / LCAS/SCK ₂	PB ₅ /TP ₁₃ / TOCXB4
8	PB ₆ /TP ₁₄ /TxD ₂	PB ₆ /TP ₁₄	PB ₆ /TP ₁₄ / DREQ ₀ /CS ₇	PB ₆ /TP ₁₄ / DREQ ₀	PB ₆ /TP ₁₄ /TxD ₂	PB ₆ /TP ₁₄ / DREQ ₀
9	PB ₇ /TP ₁₅ /RxD ₂	PB ₇ /TP ₁₅	PB ₇ /TP ₁₅ / DREQ ₁ /ADTRG	PB ₇ /TP ₁₅ / DREQ ₁ /ADTRG	PB ₇ /TP ₁₅ /RxD ₂	PB ₇ /TP ₁₅ / DREQ ₁ /ADTRG
10	RESO/FWE*	RESO/FWE*	RESO/V _{PP} *	RESO	RESO	RESO
11	Vss	Vss	Vss	Vss	Vss	Vss
12	P9 ₀ /TxD ₀	P9 ₀ /TxD ₀	P9 ₀ /TxD ₀	P9 ₀ /TxD ₀	P9 ₀ /TxD ₀	P9 ₀ /TxD ₀
13	P9 ₁ /TxD ₁	P9 ₁ /TxD ₁	P9 ₁ /TxD ₁	P9 ₁ /TxD ₁	P9 ₁ /TxD ₁	P9 ₁ /TxD ₁
14	P9 ₂ /RXD ₀	P9 ₂ /RXD ₀	P9 ₂ /RXD ₀	P9 ₂ /RXD ₀	P9 ₂ /RXD ₀	P9 ₂ /RXD ₀
15	P9 ₃ /RXD ₁	P9 ₃ /RXD ₁	P9 ₃ /RXD ₁	P9 ₃ /RXD ₁	P9 ₃ /RXD ₁	P9 ₃ /RXD ₁
16	P9 ₄ /SCK ₀ /IRQ ₄	P9 ₄ /SCK ₀ /IRQ ₄	P9 ₄ /SCK ₀ /IRQ ₄	P9 ₄ /SCK ₀ /IRQ ₄	P9 ₄ /SCK ₀ /IRQ ₄	P9 ₄ /SCK ₀ /IRQ ₄
17	P9 ₅ /SCK ₁ /IRQ ₅	P9 ₅ /SCK ₁ /IRQ ₅	P9 ₅ /SCK ₁ /IRQ ₅	P9 ₅ /SCK ₁ /IRQ ₅	P9 ₅ /SCK ₁ /IRQ ₅	P9 ₅ /SCK ₁ /IRQ ₅
18	P4 ₀ /D ₀	P4 ₀ /D ₀	P4 ₀ /D ₀	P4 ₀ /D ₀	P4 ₀ /D ₀	P4 ₀ /D ₀
19	P4 ₁ /D ₁	P4 ₁ /D ₁	P4 ₁ /D ₁	P4 ₁ /D ₁	P4 ₁ /D ₁	P4 ₁ /D ₁
20	P4 ₂ /D ₂	P4 ₂ /D ₂	P4 ₂ /D ₂	P4 ₂ /D ₂	P4 ₂ /D ₂	P4 ₂ /D ₂
21	P4 ₃ /D ₃	P4 ₃ /D ₃	P4 ₃ /D ₃	P4 ₃ /D ₃	P4 ₃ /D ₃	P4 ₃ /D ₃
22	Vss	Vss	Vss	Vss	Vss	Vss
23	P4 ₄ /D ₄	P4 ₄ /D ₄	P4 ₄ /D ₄	P4 ₄ /D ₄	P4 ₄ /D ₄	P4 ₄ /D ₄
24	P4 ₅ /D ₅	P4 ₅ /D ₅	P4 ₅ /D ₅	P4 ₅ /D ₅	P4 ₅ /D ₅	P4 ₅ /D ₅

Pin No.	On-chip-ROM Products				ROMless Products	
	H8/3067 Series	H8/3062 Series	H8/3048 Series	H8/3042 Series	H8/3006, H8/3007	H8/3002
25	P4 ₆ /D ₆	P4 ₆ /D ₆	P4 ₆ /D ₆	P4 ₆ /D ₆	P4 ₆ /D ₆	P4 ₆ /D ₆
26	P4 ₇ /D ₇	P4 ₇ /D ₇	P4 ₇ /D ₇	P4 ₇ /D ₇	P4 ₇ /D ₇	P4 ₇ /D ₇
27	P3 ₀ /D ₈	P3 ₀ /D ₈	P3 ₀ /D ₈	P3 ₀ /D ₈	D ₈	D ₈
28	P3 ₁ /D ₉	P3 ₁ /D ₉	P3 ₁ /D ₉	P3 ₁ /D ₉	D ₉	D ₉
29	P3 ₂ /D ₁₀	P3 ₂ /D ₁₀	P3 ₂ /D ₁₀	P3 ₂ /D ₁₀	D ₁₀	D ₁₀
30	P3 ₃ /D ₁₁	P3 ₃ /D ₁₁	P3 ₃ /D ₁₁	P3 ₃ /D ₁₁	D ₁₁	D ₁₁
31	P3 ₄ /D ₁₂	P3 ₄ /D ₁₂	P3 ₄ /D ₁₂	P3 ₄ /D ₁₂	D ₁₂	D ₁₂
32	P3 ₅ /D ₁₃	P3 ₅ /D ₁₃	P3 ₅ /D ₁₃	P3 ₅ /D ₁₃	D ₁₃	D ₁₃
33	P3 ₆ /D ₁₄	P3 ₆ /D ₁₄	P3 ₆ /D ₁₄	P3 ₆ /D ₁₄	D ₁₄	D ₁₄
34	P3 ₇ /D ₁₅	P3 ₇ /D ₁₅	P3 ₇ /D ₁₅	P3 ₇ /D ₁₅	D ₁₅	D ₁₅
35	Vcc	Vcc	Vcc	Vcc	Vcc	Vcc
36	P1 ₀ /A ₀	P1 ₀ /A ₀	P1 ₀ /A ₀	P1 ₀ /A ₀	A ₀	A ₀
37	P1 ₁ /A ₁	P1 ₁ /A ₁	P1 ₁ /A ₁	P1 ₁ /A ₁	A ₁	A ₁
38	P1 ₂ /A ₂	P1 ₂ /A ₂	P1 ₂ /A ₂	P1 ₂ /A ₂	A ₂	A ₂
39	P1 ₃ /A ₃	P1 ₃ /A ₃	P1 ₃ /A ₃	P1 ₃ /A ₃	A ₃	A ₃
40	P1 ₄ /A ₄	P1 ₄ /A ₄	P1 ₄ /A ₄	P1 ₄ /A ₄	A ₄	A ₄
41	P1 ₅ /A ₅	P1 ₅ /A ₅	P1 ₅ /A ₅	P1 ₅ /A ₅	A ₅	A ₅
42	P1 ₆ /A ₆	P1 ₆ /A ₆	P1 ₆ /A ₆	P1 ₆ /A ₆	A ₆	A ₆
43	P1 ₇ /A ₇	P1 ₇ /A ₇	P1 ₇ /A ₇	P1 ₇ /A ₇	A ₇	A ₇
44	Vss	Vss	Vss	Vss	Vss	Vss
45	P2 ₀ /A ₈	P2 ₀ /A ₈	P2 ₀ /A ₈	P2 ₀ /A ₈	A ₈	A ₈
46	P2 ₁ /A ₉	P2 ₁ /A ₉	P2 ₁ /A ₉	P2 ₁ /A ₉	A ₉	A ₉
47	P2 ₂ /A ₁₀	P2 ₂ /A ₁₀	P2 ₂ /A ₁₀	P2 ₂ /A ₁₀	A ₁₀	A ₁₀
48	P2 ₃ /A ₁₁	P2 ₃ /A ₁₁	P2 ₃ /A ₁₁	P2 ₃ /A ₁₁	A ₁₁	A ₁₁
49	P2 ₄ /A ₁₂	P2 ₄ /A ₁₂	P2 ₄ /A ₁₂	P2 ₄ /A ₁₂	A ₁₂	A ₁₂
50	P2 ₅ /A ₁₃	P2 ₅ /A ₁₃	P2 ₅ /A ₁₃	P2 ₅ /A ₁₃	A ₁₃	A ₁₃
51	P2 ₆ /A ₁₄	P2 ₆ /A ₁₄	P2 ₆ /A ₁₄	P2 ₆ /A ₁₄	A ₁₄	A ₁₄
52	P2 ₇ /A ₁₅	P2 ₇ /A ₁₅	P2 ₇ /A ₁₅	P2 ₇ /A ₁₅	A ₁₅	A ₁₅
53	P5 ₀ /A ₁₆	P5 ₀ /A ₁₆	P5 ₀ /A ₁₆	P5 ₀ /A ₁₆	A ₁₆	A ₁₆
54	P5 ₁ /A ₁₇	P5 ₁ /A ₁₇	P5 ₁ /A ₁₇	P5 ₁ /A ₁₇	A ₁₇	A ₁₇
55	P5 ₂ /A ₁₈	P5 ₂ /A ₁₈	P5 ₂ /A ₁₈	P5 ₂ /A ₁₈	A ₁₈	A ₁₈
56	P5 ₃ /A ₁₉	P5 ₃ /A ₁₉	P5 ₃ /A ₁₉	P5 ₃ /A ₁₉	A ₁₉	A ₁₉

Pin No.	On-chip-ROM Products				ROMless Products	
	H8/3067 Series	H8/3062 Series	H8/3048 Series	H8/3042 Series	H8/3006, H8/3007	H8/3002
57	V _{SS}	V _{SS}	V _{SS}	V _{SS}	V _{SS}	V _{SS}
58	P6 ₀ /WAIT	P6 ₀ /WAIT	P6 ₀ /WAIT	P6 ₀ /WAIT	P6 ₀ /WAIT	P6 ₀ /WAIT
59	P6 ₁ /BREQ	P6 ₁ /BREQ	P6 ₁ /BREQ	P6 ₁ /BREQ	P6 ₁ /BREQ	P6 ₁ /BREQ
60	P6 ₂ /BACK	P6 ₂ /BACK	P6 ₂ /BACK	P6 ₂ /BACK	P6 ₂ /BACK	P6 ₂ /BACK
61	P6 ₇ /φ	P6 ₇ /φ	φ	φ	P6 ₇ /φ	φ
62	STBY	STBY	STBY	STBY	STBY	STBY
63	RES	RES	RES	RES	RES	RES
64	NMI	NMI	NMI	NMI	NMI	NMI
65	V _{SS}	V _{SS}	V _{SS}	V _{SS}	V _{SS}	V _{SS}
66	EXTAL	EXTAL	EXTAL	EXTAL	EXTAL	EXTAL
67	XTAL	XTAL	XTAL	XTAL	XTAL	XTAL
68	V _{CC}	V _{CC}	V _{CC}	V _{CC}	V _{CC}	V _{CC}
69	P6 ₃ /AS	P6 ₃ /AS	P6 ₃ /AS	P6 ₃ /AS	AS	AS
70	P6 ₄ /RD	P6 ₄ /RD	P6 ₄ /RD	P6 ₄ /RD	RD	RD
71	P6 ₅ /HWR	P6 ₅ /HWR	P6 ₅ /HWR	P6 ₅ /HWR	HWR	HWR
72	P6 ₆ /LWR	P6 ₆ /LWR	P6 ₆ /LWR	P6 ₆ /LWR	LWR	LWR
73	MD ₀	MD ₀	MD ₀	MD ₀	MD ₀	MD ₀
74	MD ₁	MD ₁	MD ₁	MD ₁	MD ₁	MD ₁
75	MD ₂	MD ₂	MD ₂	MD ₂	MD ₂	MD ₂
76	AV _{CC}	AV _{CC}	AV _{CC}	AV _{CC}	AV _{CC}	AV _{CC}
77	V _{REF}	V _{REF}	V _{REF}	V _{REF}	V _{REF}	V _{REF}
78	P7 ₀ /AN ₀	P7 ₀ /AN ₀	P7 ₀ /AN ₀	P7 ₀ /AN ₀	P7 ₀ /AN ₀	P7 ₀ /AN ₀
79	P7 ₁ /AN ₁	P7 ₁ /AN ₁	P7 ₁ /AN ₁	P7 ₁ /AN ₁	P7 ₁ /AN ₁	P7 ₁ /AN ₁
80	P7 ₂ /AN ₂	P7 ₂ /AN ₂	P7 ₂ /AN ₂	P7 ₂ /AN ₂	P7 ₂ /AN ₂	P7 ₂ /AN ₂
81	P7 ₃ /AN ₃	P7 ₃ /AN ₃	P7 ₃ /AN ₃	P7 ₃ /AN ₃	P7 ₃ /AN ₃	P7 ₃ /AN ₃
82	P7 ₄ /AN ₄	P7 ₄ /AN ₄	P7 ₄ /AN ₄	P7 ₄ /AN ₄	P7 ₄ /AN ₄	P7 ₄ /AN ₄
83	P7 ₅ /AN ₅	P7 ₅ /AN ₅	P7 ₅ /AN ₅	P7 ₅ /AN ₅	P7 ₅ /AN ₅	P7 ₅ /AN ₅
84	P7 ₆ /AN ₆ /DA ₀	P7 ₆ /AN ₆ /DA ₀	P7 ₆ /AN ₆ /DA ₀	P7 ₆ /AN ₆ /DA ₀	P7 ₆ /AN ₆ /DA ₀	P7 ₆ /AN ₆
85	P7 ₇ /AN ₇ /DA ₁	P7 ₇ /AN ₇ /DA ₁	P7 ₇ /AN ₇ /DA ₁	P7 ₇ /AN ₇ /DA ₁	P7 ₇ /AN ₇ /DA ₁	P7 ₇ /AN ₇
86	AV _{SS}	AV _{SS}	AV _{SS}	AV _{SS}	AV _{SS}	AV _{SS}
87	P8 ₀ /RFSH/IRQ ₀	P8 ₀ /IRQ ₀	P8 ₀ /RFSH/IRQ ₀	P8 ₀ /RFSH/IRQ ₀	P8 ₀ /RFSH/IRQ ₀	P8 ₀ /RFSH/IRQ ₀
88	P8 ₁ /CS ₃ /IRQ ₁	P8 ₁ /CS ₃ /IRQ ₁	P8 ₁ /CS ₃ /IRQ ₁	P8 ₁ /CS ₃ /IRQ ₁	P8 ₁ /CS ₃ /IRQ ₁	P8 ₁ /CS ₃ /IRQ ₁

Pin No.	On-chip-ROM Products				ROMless Products	
	H8/3067 Series	H8/3062 Series	H8/3048 Series	H8/3042 Series	H8/3006, H8/3007	H8/3002
89	$P8_2/\overline{CS}_2/\overline{IRQ}_2$	$P8_2/\overline{CS}_2/\overline{IRQ}_2$	$P8_2/\overline{CS}_2/\overline{IRQ}_2$	$P8_2/\overline{CS}_2/\overline{IRQ}_2$	$P8_2/\overline{CS}_2/\overline{IRQ}_2$	$P8_2/\overline{CS}_2/\overline{IRQ}_2$
90	$P8_3/\overline{CS}_1/\overline{IRQ}_3/\overline{ADTRG}$	$P8_3/\overline{CS}_1/\overline{IRQ}_3/\overline{ADTRG}$	$P8_3/\overline{CS}_1/\overline{IRQ}_3$	$P8_3/\overline{CS}_1/\overline{IRQ}_3$	$P8_3/\overline{CS}_1/\overline{IRQ}_3/\overline{ADTRG}$	$P8_3/\overline{CS}_1/\overline{IRQ}_3$
91	$P8_4/\overline{CS}_0$	$P8_4/\overline{CS}_0$	$P8_4/\overline{CS}_0$	$P8_4/\overline{CS}_0$	$P8_4/\overline{CS}_0$	$P8_4/\overline{CS}_0$
92	Vss	Vss	Vss	Vss	Vss	Vss
93	$PA_0/TP_0/\overline{TEND}_0/\overline{TCLKA}$	$PA_0/TP_0/\overline{TCLKA}$	$PA_0/TP_0/\overline{TEND}_0/\overline{TCLKA}$	$PA_0/TP_0/\overline{TEND}_0/\overline{TCLKA}$	$PA_0/TP_0/\overline{TEND}_0/\overline{TCLKA}$	$PA_0/TP_0/\overline{TEND}_0/\overline{TCLKA}$
94	$PA_1/TP_1/\overline{TEND}_1/\overline{TCLKB}$	$PA_1/TP_1/\overline{TCLKB}$	$PA_1/TP_1/\overline{TEND}_1/\overline{TCLKB}$	$PA_1/TP_1/\overline{TEND}_1/\overline{TCLKB}$	$PA_1/TP_1/\overline{TEND}_1/\overline{TCLKB}$	$PA_1/TP_1/\overline{TEND}_1/\overline{TCLKB}$
95	$PA_2/TP_2/\overline{TIOCA}_0/\overline{TCLKC}$	$PA_2/TP_2/\overline{TIOCA}_0/\overline{TCLKC}$	$PA_2/TP_2/\overline{TIOCA}_0/\overline{TCLKC}$	$PA_2/TP_2/\overline{TIOCA}_0/\overline{TCLKC}$	$PA_2/TP_2/\overline{TIOCA}_0/\overline{TCLKC}$	$PA_2/TP_2/\overline{TIOCA}_0/\overline{TCLKC}$
96	$PA_3/TP_3/\overline{TIOCB}_0/\overline{TCLKD}$	$PA_3/TP_3/\overline{TIOCB}_0/\overline{TCLKD}$	$PA_3/TP_3/\overline{TIOCB}_0/\overline{TCLKD}$	$PA_3/TP_3/\overline{TIOCB}_0/\overline{TCLKD}$	$PA_3/TP_3/\overline{TIOCB}_0/\overline{TCLKD}$	$PA_3/TP_3/\overline{TIOCB}_0/\overline{TCLKD}$
97	$PA_4/TP_4/\overline{TIOCA}_1/A_{23}$	$PA_4/TP_4/\overline{TIOCA}_1/A_{23}$	$PA_4/TP_4/\overline{TIOCA}_1/\overline{CS}_6/A_{23}$	$PA_4/TP_4/\overline{TIOCA}_1/A_{23}$	$PA_4/TP_4/\overline{TIOCA}_1/A_{23}$	$PA_4/TP_4/\overline{TIOCA}_1/A_{23}$
98	$PA_5/TP_5/\overline{TIOCB}_1/A_{22}$	$PA_5/TP_5/\overline{TIOCB}_1/A_{22}$	$PA_5/TP_5/\overline{TIOCB}_1/\overline{CS}_5/A_{22}$	$PA_5/TP_5/\overline{TIOCB}_1/A_{22}$	$PA_5/TP_5/\overline{TIOCB}_1/A_{22}$	$PA_5/TP_5/\overline{TIOCB}_1/A_{22}$
99	$PA_6/TP_6/\overline{TIOCA}_2/A_{21}$	$PA_6/TP_6/\overline{TIOCA}_2/A_{21}$	$PA_6/TP_6/\overline{TIOCA}_2/\overline{CS}_4/A_{21}$	$PA_6/TP_6/\overline{TIOCA}_2/A_{21}$	$PA_6/TP_6/\overline{TIOCA}_2/A_{21}$	$PA_6/TP_6/\overline{TIOCA}_2/A_{21}$
100	$PA_7/TP_7/\overline{TIOCB}_2/A_{20}$	$PA_7/TP_7/\overline{TIOCB}_2/A_{20}$	$PA_7/TP_7/\overline{TIOCB}_2/A_{20}$	$PA_7/TP_7/\overline{TIOCB}_2/A_{20}$	$PA_7/TP_7/\overline{TIOCB}_2/A_{20}$	$PA_7/TP_7/\overline{TIOCB}_2/A_{20}$

Note: * Functions as \overline{RES}_0 in the mask ROM versions, and as FWE in the flash memory and flash memory R versions.

H8/3006, H8/3007 Hardware Manual

Publication Date: 1st Edition, December 1997
4th Edition, January 2000

Published by: Electronic Devices Sales & Marketing Group
Semiconductor & Integrated Circuits
Hitachi, Ltd.

Edited by: Technical Documentation Group
Hitachi Kodaira Semiconductor Co., Ltd.

Copyright © Hitachi, Ltd., 1997. All rights reserved. Printed in Japan.