

#### DESCRIPTION

The **LX1720** is a highly-integrated, **Switching Class-D Stereo Power Amplifier Controller IC** with power and size features that make it ideal for multimedia computer applications, as well as other applications where high fidelity sound is required.

With input voltage ranging from 7V-15V, the LX1720 is designed to operate over the full 20Hz to 20kHz audio range. Signal distortion measurements using industry standard 1kHz signal yields THD + noise levels < 1% (10 watts output).

Its high efficiency (>92%) eliminates the need for heat sinks — even while delivering more than 10W<sub>RMS</sub> across 8 ohms per channel (20W<sub>RMS</sub> stereo) with 0.1 ohm SO-8 power FETs.

The LX1720's output power is limited only by external FETs and available supply voltage.

While offering breakthrough performance capabilities for notebooks, the LX1720 is equally attractive for multimedia systems or to drive full-size home theatre speakers.

**IMPORTANT:** For the most current data, consult Linfinity's web site: <http://www.linfinity.com>.

#### KEY FEATURES

- Integrated Switching (Class-D) Stereo Power Amplifier Controller IC
- Delivers >10W<sub>RMS</sub> Across 8Ω /Channel (20W<sub>RMS</sub> stereo)
- Output Power Limited Only By External FETs And Available Supply Voltage
- Will Drive A Wide Range Of Speakers
- High Efficiency (>92%)
- Due To High Efficiency, Power FETs Do Not Require Heatsinking
- Audio Bandwidth Of 20Hz to 20kHz
- Wide Input Voltage Range Of 7V-15V
- Low Output Signal Distortion <1%
- High Operating Frequency (350kHz) Helps To Reduce Output Filter Size
- Compact Design Minimizes EMI / RFI

#### PRODUCT HIGHLIGHT

##### EFFICIENCY COMPARISON OF THE CLASS-D AMPLIFIER

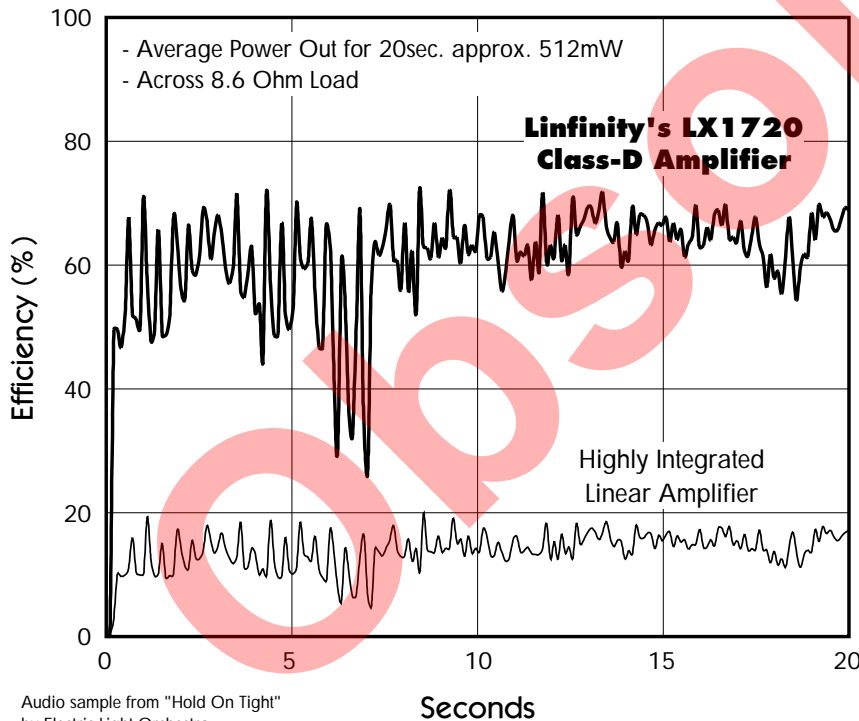

#### APPLICATIONS / BENEFITS

##### Notebook Computers:

- Replaces existing internal low power linear amplifier with a high efficiency Class-D amplifier
- Enables the use of virtually any external speaker without amplification
- Precious battery life is extended
- Fully protected power topology can withstand shorts or external speaker failures without damage, overheating or posing fire hazard

##### Desktop Computers:

- Output power capability of up to 20W<sub>RMS</sub> per channel in an area less than 3"x3", without using expensive heatsinks
- Greatly reduced power supply requirements when compared to a linear solution of same power capabilities
- Any speakers can be used including conventional home stereo speakers
- Very light weight circuitry will not add to the overall weight of the system
- Multimedia amplifier can be directly incorporated on the motherboard using surface mount components

##### APPLICATION NOTE AN-11

available on our web site  
or call 1-800-LMI-7011

#### PACKAGE ORDER INFO

T <sub>J</sub> (°C)	Maximum VDD	DB Plastic SSOP 44-pin
0 to 70	15V	LX1720-01CDB

Note: Available in Tape & Reel.  
Append the letter "T" to part number. (i.e. LX1720-01CDBT)

## SWITCHING CLASS-D, STEREO POWER AMPLIFIER CONTROLLER IC

### PRODUCTION DATA SHEET

#### ABSOLUTE MAXIMUM RATINGS (Note 1)

Supply Voltage (PVDD, VDD) .....	-0.3V to 18V
RPWM .....	-0.3V to $V_{CN}+0.3V$
INPUT (R), INPUT (L) .....	-0.3V to $V_{CN}+0.3V$
FBK+(R), FBK-(R), FBK+(L), FBK-(L), SLEEP .....	-0.3V to $V_{DD}$
MUTE (R), MUTE (L) .....	-0.3V to 6.0V
EAOUT (R), EAOUT (L) .....	-0.3V to $V_{CN}+0.3V$
CPWM, CT .....	-0.3V to $V_{CN}+0.3V$
IS+, LIS-, RIS+ .....	$V_{DD}-2$ to $V_{DD}$
Operating Junction Temperature	
Plastic (DB Package) .....	125°C
Storage Temperature Range .....	-65°C to 150°C
Lead Temperature (Soldering, 10 seconds) .....	300°C

Note 1. Exceeding these ratings could cause damage to the device. All voltages are with respect to Ground. Currents are positive into, negative out of the specified terminal.

#### THERMAL DATA

##### DB PACKAGE:

**THERMAL RESISTANCE-JUNCTION TO AMBIENT,  $\theta_{JA}$**  **65°C/W**

Junction Temperature Calculation:  $T_J = T_A + (P_D \times \theta_{JA})$ .  
The  $\theta_{JA}$  numbers are guidelines for the thermal performance of the device/pc-board system. All of the above assume no ambient airflow.

#### PACKAGE PIN OUTS

RIS-	1	44	FBK- (R)
LIS-	2	43	FBK+ (R)
IS+	3	42	N.C.
RPWM	4	41	VDD
CPWM	5	40	CP
CN	6	39	PVDD
N.C.	7	38	PGND
CT	8	37	P- (R)
RT	9	36	N- (R)
RBIAS	10	35	N+ (R)
GND	11	34	P+ (R)
AGND	12	33	P- (L)
INPUT (R)	13	32	N- (L)
INPUT (L)	14	31	N+ (L)
SLEEP	15	30	P+ (L)
EAIN (R)	16	29	PGND
N.C.	17	28	PVDD
EAOUT (R)	18	27	FBK- (L)
FAOUT (R)	19	26	FBK+ (L)
EAOUT (L)	20	25	GND
EAIN (L)	21	24	MUTE (L)
FAOUT (L)	22	23	MUTE (R)

DB PACKAGE  
(Top View)

#### FUNCTIONAL PIN DESCRIPTION

Pin Name	Description	Pin Name	Description
RIS-	Right Channel Current Sense Input	FAOUT (R)	Output of Right Feedback Amp
LIS-	Left Channel Current Sense Input	EAOUT (L)	Left Channel Error Amplifier Output
IS+	Positive Current Sense Input	EAIN (L)	Inverting Input of Left Channel Error Amp
RPWM	PWM Resistor Connection	FAOUT (L)	Output of Left Feedback Amp
CPWM	PWM Capacitor Connection	FBK+(R), FBK-(R)	Right Channel Feedback Inputs
CN	Supply Decoupling for NFET Drivers	CP	Supply Decoupling for PFET Drivers
CT	Oscillator Timing Capacitor Connection	PVDD	Output Driver Supply Voltage (2-pins)
RT	Oscillator Timing Resistor	VDD	Analog Supply Voltage
RBIAS	Bias Setting Resistor for Error Amps	PGND	IC Power Ground for the Output Drivers (2-pins)
GND	Ground (2-pins)	P+(R), N+(R), P-(R), N-(R)	Right Channel Gate Drive Outputs
AGND	Audio Input Ground	P+(L), N+(L), P-(L), N-(L)	Left Channel Gate Drive Outputs
INPUT (R)	Right Channel Input	FBK+(L), FBK-(L)	Left Channel Feedback Inputs
INPUT (L)	Left Channel Input	MUTE (R), MUTE (L)	Mute Inputs
SLEEP	Sleep Input		
EAIN (R)	Inverting Input of Right Channel Error Amp		
EAOUT (R)	Right Channel Error Amplifier Output		

NOT RECOMMENDED FOR NEW DESIGN

## SWITCHING CLASS-D, STEREO POWER AMPLIFIER CONTROLLER IC

### PRODUCTION DATA SHEET

#### ELECTRICAL CHARACTERISTICS

(Unless otherwise specified, the following specifications apply over the operating ambient temperature  $0^{\circ}\text{C} \leq T_A \leq 70^{\circ}\text{C}$ .  
Test conditions:  $R_T = 30\text{k}$ ,  $C_T = 100\text{pF}$ ,  $V_{DD} = PV_{DD} = 15\text{V}$ .)

Parameter	Symbol	Test Conditions	LX1720			Units
			Min.	Typ.	Max.	
<b>Oscillator Section</b>						
Oscillator Frequency			280	330	380	kHz
Oscillator Peak Voltage				2.5		V
Oscillator Valley Voltage				200		mV
Oscillator Max. Frequency				1		MHz
Voltage Stability				1	2	%
Temperature Stability				2		%
<b>Error Amplifiers</b>						
Input Offset Voltage				5		mV
DC Open Loop Gain				60		dB
Unity Gain Bandwidth				7		MHz
High Output Voltage		$I_{OUT} = -100\mu\text{A}$	4			V
Low Output Voltage		$I_{OUT} = +100\mu\text{A}$			50	mV
Input Common Mode Range			1		5	V
Input Bias Current					1	$\mu\text{A}$
<b>Input Amplifiers</b>						
Stage Gain		Set by Internal Resistors	3.465	3.5	3.535	V/V
Input Impedance				42		$\text{k}\Omega$
<b>Feedback Amplifiers</b>						
High Output Voltage		$I_{OUT} = -250\mu\text{A}$	4			V
Low Output Voltage		$I_{OUT} = +250\mu\text{A}$			50	mV
Common Mode Rejection				70		dB
Input Common Mode Range			0		$V_{DD}$	V
Input Impedance				388		$\text{k}\Omega$
Stage Gain	LX1720-01	Set by Internal Resistors	89	91	93	mV/V
<b>Current Limit Comparators</b>						
Voltage Sense Threshold			200	220	240	mV
Comparator Response Time				500		nsec
<b>PWM Comparators</b>						
CPWM Delay To Output				250		nsec
<b>PWM Current Generator</b>						
CPWM Charge Current		RPWM = 75k		75		$\mu\text{A}$
Impedance of Internal Discharge FET				20		$\Omega$
<b>Output Drivers For The N-Channel MOSFETs</b>						
Ext. NFET Drivers, Low Level Voltage	$V_{OL}$	$I_{SINK} = 3\text{mA}$		30	100	mV
		$I_{SINK} = 75\text{mA}$		1	1.5	V
Ext. NFET Drivers, High Level Voltage	$V_{OH}$	$I_{SOURCE} = 3\text{mA}$		30	100	mV
		$I_{SOURCE} = 75\text{mA}$ , $C_N = 5.2\text{V}$ (applied externally)		1	1.5	V
<b>Output Drivers For The P-Channel MOSFETs</b>						
Ext. PFET Drivers, Low Level Voltage	$V_{OL}$	$I_{SINK} = 3\text{mA}$		30	100	mV
		$I_{SINK} = 75\text{mA}$		1	1.5	V
Ext. PFET Drivers, High Level Voltage	$V_{OH}$	$I_{SOURCE} = 3\text{mA}$		30	100	mV
		$I_{SOURCE} = 75\text{mA}$ , $C_P = 5.2\text{V}$ (applied externally)		1	1.5	V

NOT RECOMMENDED FOR NEW DESIGN

## SWITCHING CLASS-D, STEREO POWER AMPLIFIER CONTROLLER IC

## PRODUCTION DATA SHEET

## ELECTRICAL CHARACTERISTICS (Continued)

Parameter	Symbol	Test Conditions	LX1720			Units
			Min.	Typ.	Max.	
<b>Undervoltage Lockout Section</b>						
Start Threshold Voltage			6.3	6.5	6.7	V
UV Lockout Hysteresis				500		mV
UVLO Delay To Output Enable				976		clkcy
<b>Supply Current</b>						
Sleep Current		SLEEP Input = 0V, T <sub>A</sub> = 25°C		20		μA
Operating Current		SLEEP Input = 2V, V <sub>IN</sub> = 15V, No MOSFETs Connected		5	7	mA
Sleep To Output Enable				976		clkcy
Sleep Threshold			1.2	1.45	1.6	V
<b>Mute Section</b>						
Mute Threshold			1.6	1.7	1.8	V

NOT RECOMMENDED FOR NEW DESIGN

SWITCHING CLASS-D, STEREO POWER AMPLIFIER CONTROLLER IC

PRODUCTION DATA SHEET

BLOCK DIAGRAM

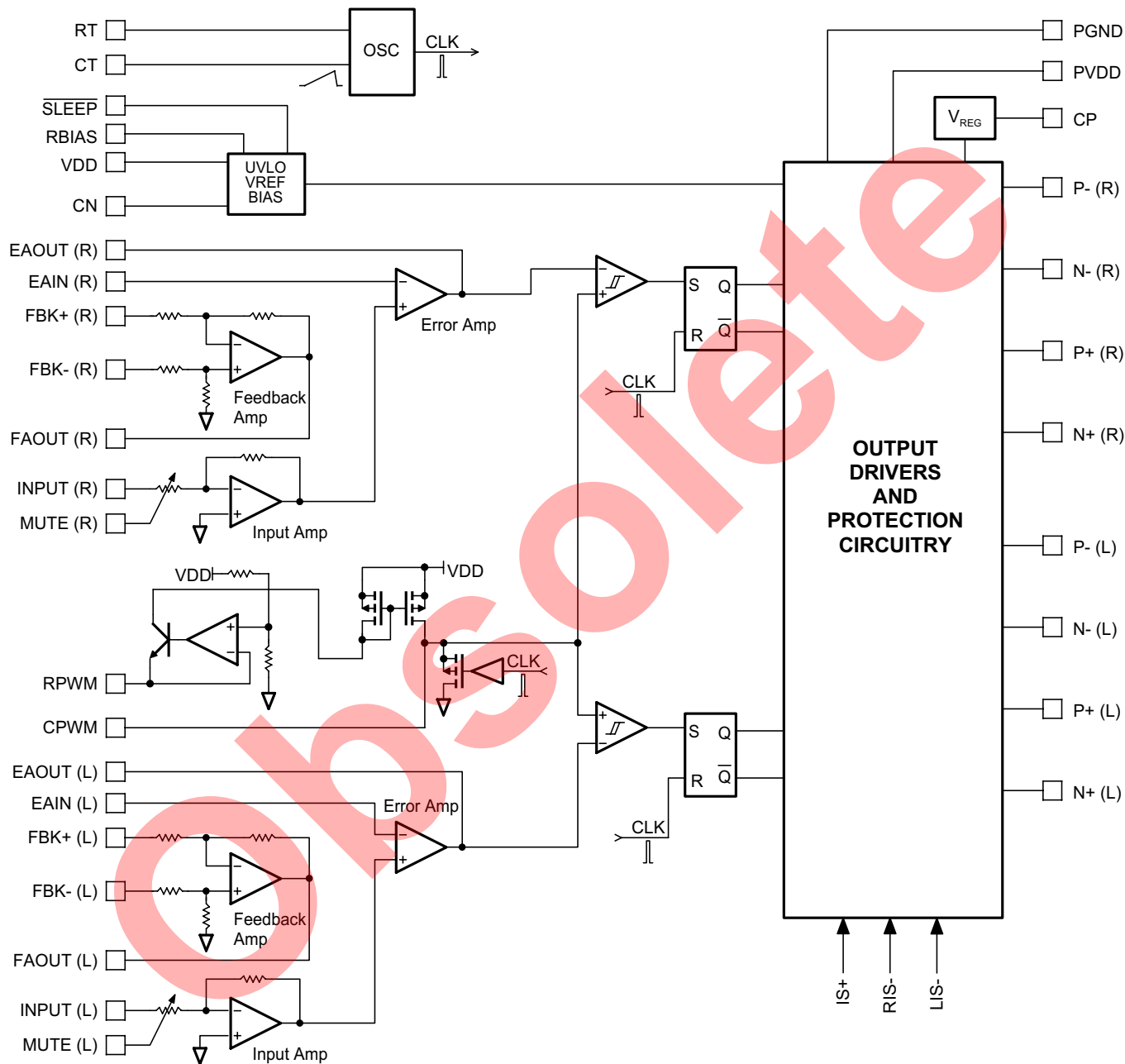

FIGURE 1 — LX1720 Block Diagram

NOT RECOMMENDED FOR NEW DESIGN

SWITCHING CLASS-D, STEREO POWER AMPLIFIER CONTROLLER IC

PRODUCTION DATA SHEET

TYPICAL APPLICATION

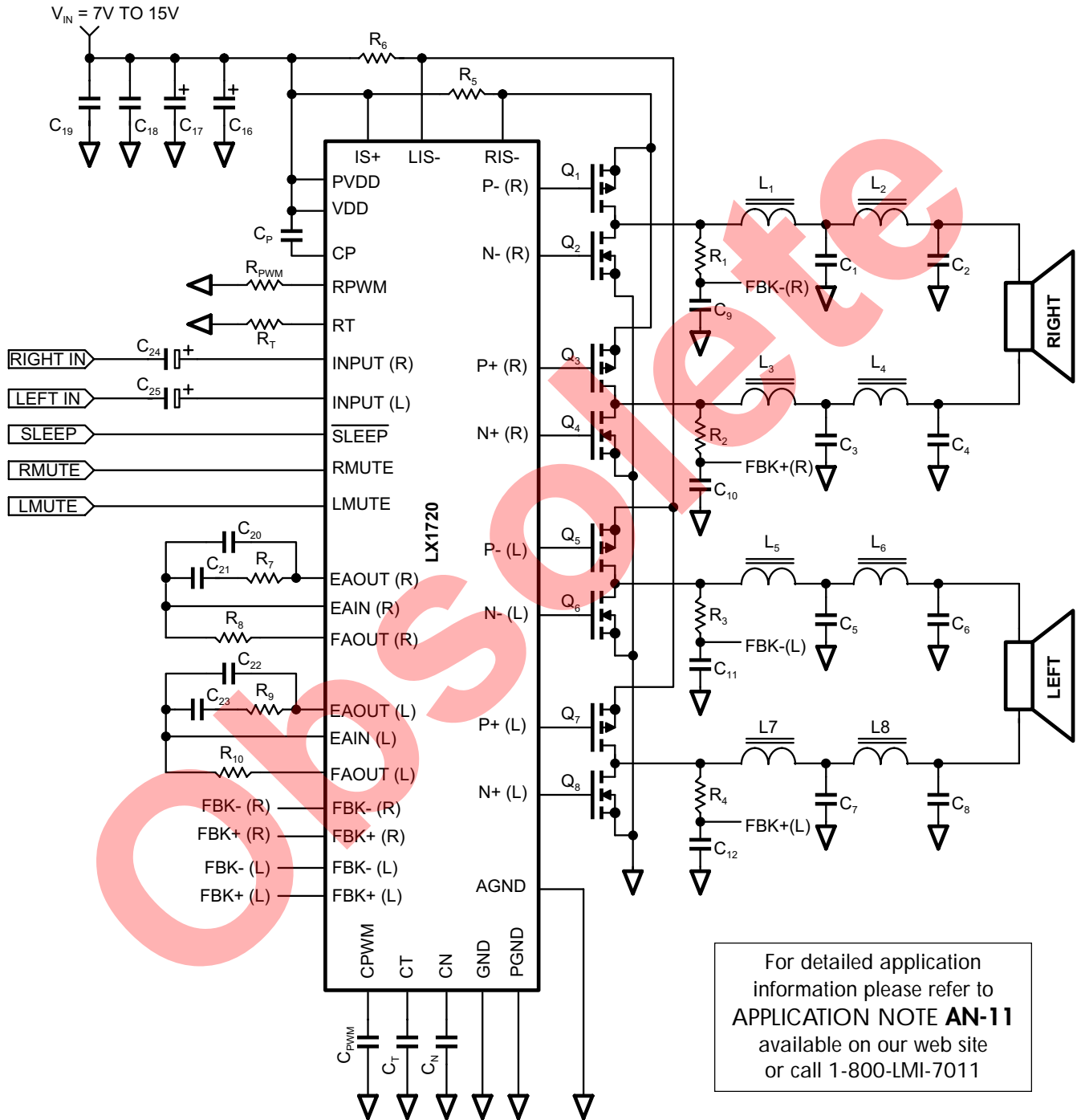

For detailed application information please refer to APPLICATION NOTE AN-11 available on our web site or call 1-800-LMI-7011

FIGURE 2 — Typical Class-D Stereo Switching Amplifier Circuit Application

NOT RECOMMENDED FOR NEW DESIGN

PRODUCTION DATA - Information contained in this document is proprietary to Linfinity, and is current as of publication date. This document may not be modified in any way without the express written consent of Linfinity. Product processing does not necessarily include testing of all parameters. Linfinity reserves the right to change the configuration and performance of the product and to discontinue product at any time.