

M6000 series
H6000 series
VCXO 5.0V
Full/Half size, Thru-hole, HCMOS/TTL

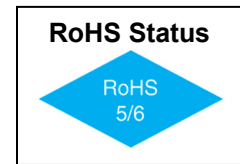

Features

- Frequency range of 1KHz to 150MHz
- Industrial temperature range of -40 to +85°C
- Excellent incremental and best-straight-line linearity
- Start-up time is less than 5ms



Applications

- Phase locked loops
- xDSL customer premise equipment
- Cable modems
- ATM/SONET/SDH

Electrical Specifications

Parameter	Symbol	Condition	Min	Typ	Max	Unit	Note
Frequency Range	F		0.001		150	MHz	
Frequency Stability	$\Delta F/F$	Operating Temperature at 25°C		± 40	± 50	ppm	
Aging		First Year After First Year		3 1		ppm ppm/yr	
Operating Temperature	T		-40°		+85°	°C	
Supply Voltage	V _{CC}		4.5	5.0	5.5	V	
Supply Current	I _{CC}			30	45	mA	
Output Levels		"0" Level, sinking 16mA "1" Level, sourcing 10mA	V _{DD} -0.4		0.4	V	
Rise & Fall Times		From 0.4 to (V _{DD} -.4) V (Above 35 MHz)		2.5	4 2	ns	
Input Impedance		Pin 5, V _C	15	1000		kOhm	
Symmetry		At V _{DD} /2			45/55	%	
Control Voltage Bandwidth			15	150		kHz	

M6000 series
H6000 series
VCXO 5.0V
Full/Half size, Thru-hole, HCMOS/TTL



Environmental and Mechanical Conditions

Parameter	Conditions
Shock	1000 Gs, 0.35 ms, 1/2 sine wave, 3 shocks in each plane
Vibration	10-2000 Hz of 0.06" d.a. or 20 Gs, whichever is less
Humidity	Resistant to 85° R.H. at 85°C
Gross Leak	Each unit checked in 125°C fluorocarbon
Fine Leak	Mass spectrometer leak rate less than 2 X 10 ⁻⁸ atm, cc/sec of helium
Pins	Kovar, nickel plated with 60/40 solder coat
Bend Test	Will withstand two bends of 90° from reference
Header	Steel, with nickel plated
Case	Stainless steel, type 304
Marking	Permanent black epoxy ink or laser marked
Resistance to Solvents	MIL STD 202, Method 215

Center frequency is between two voltages with ±50 ppm stability

MODEL	Control Voltage (Volts)	Frequency Deviation (ppm)	Guaranteed Capture Range (ppm)	Control Voltage at Center Frequency	Center Frequency Stability (ppm)
6001	0.3 to 10.0	± 175 min	± 175	2.5 to 5.0	± 40, typ ± 50, max
6002	0.3 to 4.0	± 75 min	± 75	1.3 to 2.3	
6003	0.3 to 10.0	± 175 to 300	± 175	2.5 to 5.0	
6004	0.3 to 4.0	± 125 min	± 125	1.3 to 2.3	
6005	1.0 to 4.0	± 75 to 300	± 75	1.8 to 3.0	
6006	0 to 5.0	± 150 min	± 150	—	
6007	0.5 to 4.5	± 125 to 250	± 125	1.8 to 3.0	

Center frequency is at 2.5V with ±20 ppm stability

MODEL	Control Voltage (Volts)	Frequency Deviation (ppm)	Guaranteed Capture Range (ppm)	Control Voltage at Center Frequency	Center Frequency Stability (ppm)
6021	0.5 to 4.5	± 75 to 150	± 75	2.5	± 30, typ ± 50, max
6022	0.5 to 4.5	± 100 to 200	± 100	2.5	
6023	0.5 to 4.5	± 150 to 300	± 150	2.5	

DESCRIPTIONS

M6001, H6001	±175 ppm, min. deviation when using 0.3 to 10V control-voltage
M6002, H6002	±75 ppm, min. deviation when using 0.3 to 4.0V control-voltage
M6003, H6003	±175 ppm to ±300 ppm deviation when using 0.3 to 10V control-voltage
M6004, H6004	±125 ppm deviation when using 0.3 to 4.0V control-voltage
M6005, H6005	±75 ppm to ±300 ppm deviation when using 1.0 to 4.0 control-voltage, for use where the control voltage is 1 volt off both rails
M6006, H6006	±150 ppm, min. deviation when using 0 to 5.0 control-voltage
M6007, H6007	±125 ppm to ±250 ppm deviation when using 0.5 to 4.5 control-voltage
M6021, H6021	±75 ppm capture when using 0.5 to 4.5V control-voltage and 2.5V center with 50 ppm stability
M6022, H6022	±100 ppm capture when using 0.5 to 4.5V control-voltage and 2.5V center with 50 ppm stability
M6023, H6023	±150 ppm capture when using 0.5 to 4.5V control-voltage and 2.5V center with 50 ppm stability



M6000 series
H6000 series
VCXO 5.0V
Full/Half size, Thru-hole, HCMOS/TTL



Pin #	Full size (M)	Half size (H)
1	Control Voltage	Control Voltage
4	N/C	Ground & Case
5	N/C	Output
7	Ground & Case	N/C
8	Output	+5.0V, V _{DD}
14	+5.0V, V _{DD}	N/C

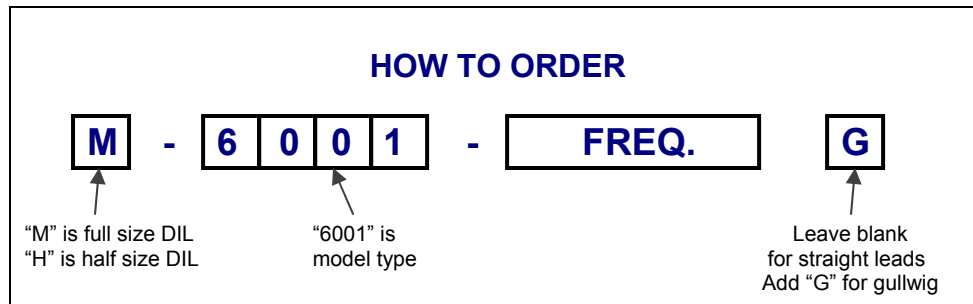
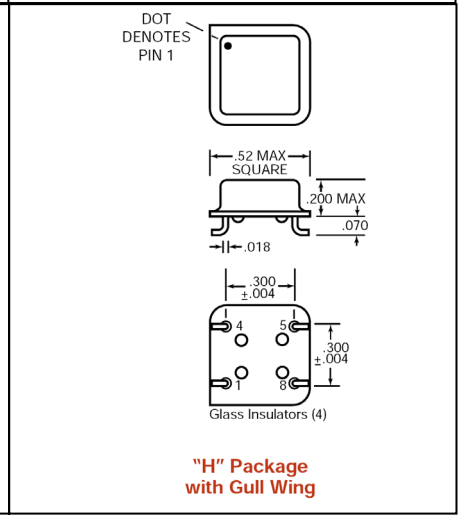
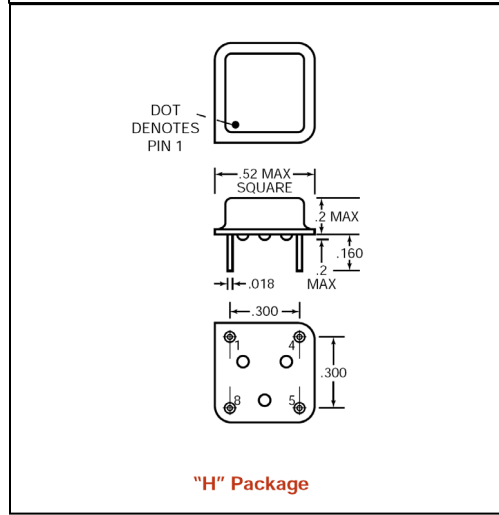
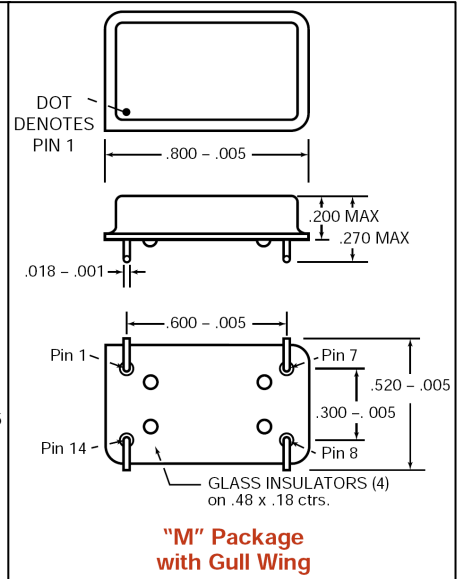
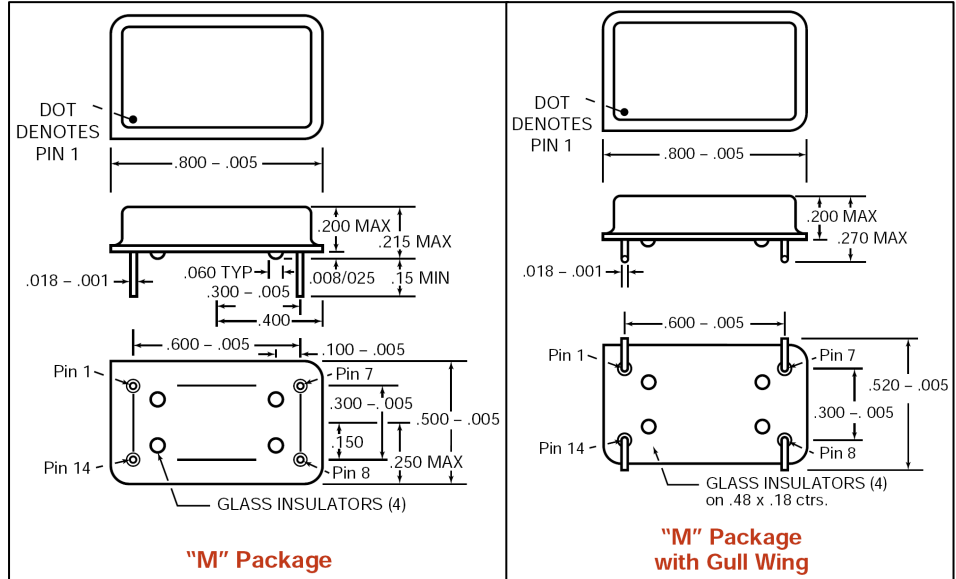

M6000 series
H6000 series
VCXO 5.0V
Full/Half size, Thru-hole, HCMOS/TTL

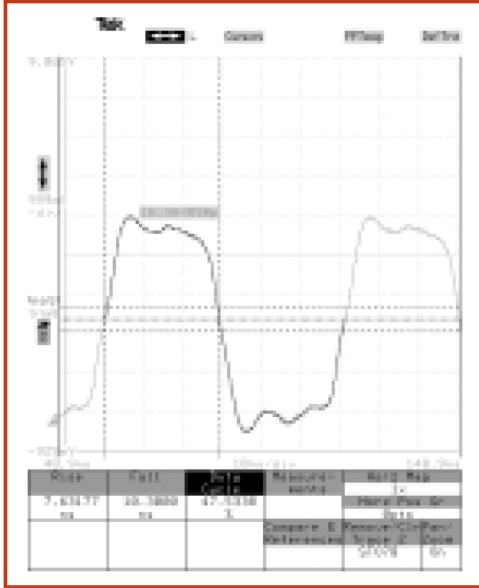
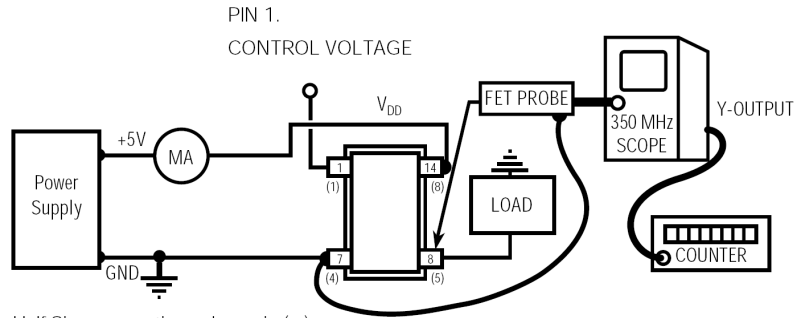

Fig. 1 M6022-16.384M,
with 50 pf load



Half Size connections shown in ()

To adapt Fet probe to receptacle
use Tektronix Part #103-0164-00

To connect output to scope use
use Tektronix Part #131-0258-00 (receptacle)

ALL OSCILLATORS HAVE INTERNAL BYPASS CAPACITORS

TEST CIRCUIT

FREQUENCY VS. CONTROL VOLTAGE FOR TYPICAL DEVICE

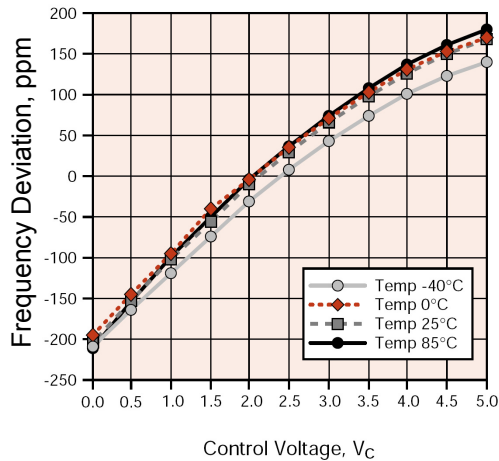

Fig. 2 Frequency vs. Control Voltage

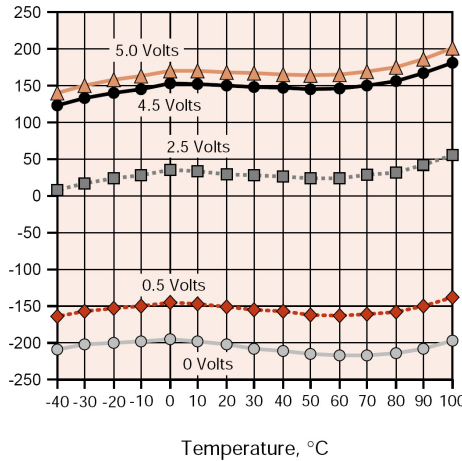

Fig. 3 Frequency vs. Temperature

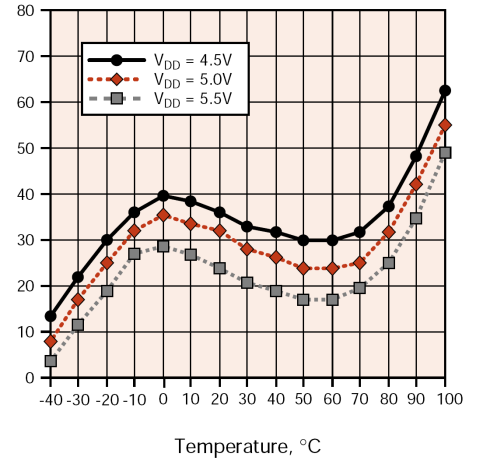

Fig. 4 Frequency vs. Temperature @ 2.5V
Control Voltage

