

10/100 BASE-TX SINGLE-PORT TRANSFORMER MODULES

Military/Aerospace Grade

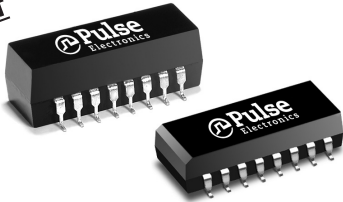

- Compliant with IEEE802.3 standards
- 350uH OCL with 8mA DC bias
- Operating temperature: -55°C to +125°C
- Epoxy encapsulated package withstands 235°C peak temperature profile

Electrical specification @25°C

| Part Number | Insertion Loss (dB MIN) | Return Loss (dB MAX) | | | | Crosstalk (dB MAX) | | | | Differential to Common Mode Rejection (dB MAX) | | | Common to Common Mode Rejection (dB MAX) | | |
|-------------|-------------------------|----------------------|--------|--------|--------|--------------------|--------|--------|---------|--|-----------|------------|--|-----------|------------|
| | 0.1-100 MHz | 2-30 MHz | 50 MHz | 60 MHz | 80 MHz | 1 MHz | 30 MHz | 60 MHz | 100 MHz | 1-30 MHz | 30-60 MHz | 60-100 MHz | 1-30 MHz | 30-60 MHz | 60-100 MHz |
| 100B-1027X | -1.5 | -18 | -14 | -12 | -10 | -50 | -45 | -38 | -33 | -42 | -37 | -33 | -40 | -35 | -30 |

Mechanicals

Schematic

100B-1027X

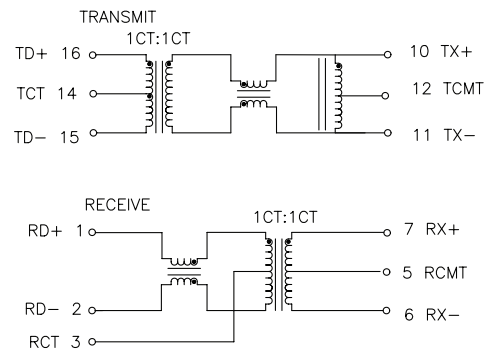
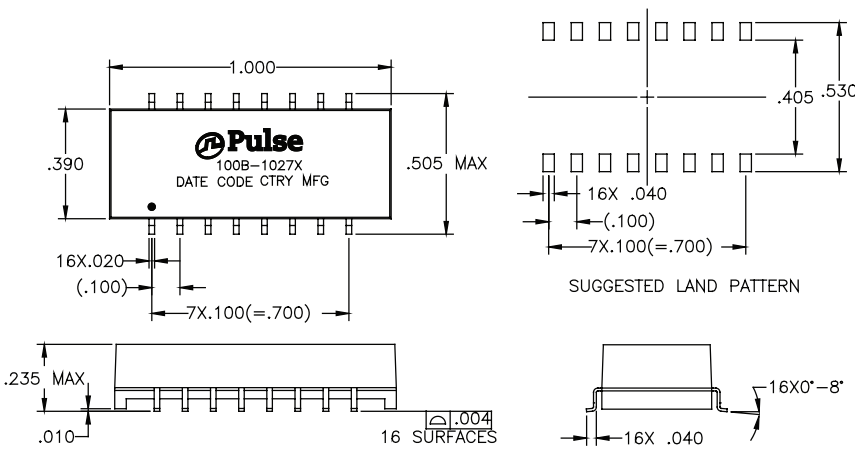

Weight..... 3.70grams
Tape & Reel..... 300/reel
Tube..... 20/tube

Dimensions: Inches
mm
Unless otherwise specified,
all tolerances are ± .010
0.25

For More Information

Pulse North America Headquarters
Two Pearl Buck Court
Bristol, PA 19007
U.S.A.

Tel: 215 781 6400
Fax: 215 781 6403

Pulse Europe
Einsteinstrasse 1
D-71083 Herrenberg
Germany

Tel: 49 7032 7806 0
Fax: 49 7032 7806 135

Pulse China Headquarters
B402, Shenzhen Academy of
Aerospace Technology Bldg.
10th Kejinan Road
High-Tech Zone
Nanshan District
Shenzhen, PR China 518057

Tel: 86 755 33966678
Fax: 86 755 33966700

Pulse North China
Room 2704/2705
Super Ocean Finance Ctr.
2067 Yan An Road West
Shanghai 200336
China

Tel: 86 21 62787060
Fax: 86 2162786973

Pulse South Asia
135 Joo Seng Road
#03-02
PM Industrial Bldg.
Singapore 368363

Tel: 65 6287 8998
Fax: 65 6287 8998

Pulse North Asia
3F, No. 198
Zhongyuan Road
Zhongli City
Taoyuan County 320
Taiwan R. O. C.
Tel: 886 3 4356768
Fax: 886 3 4356823 (Pulse)
Fax: 886 3 4356820 (FRE)

Performance warranty of products offered on this data sheet is limited to the parameters specified. Data is subject to change without notice. Other brand and product names mentioned herein may be trademarks or registered trademarks of their respective owners. © Copyright, 2012. Pulse Electronics, Inc. All rights reserved.