

TC9421F

SYSTEM ELECTRONIC VOLUME

TC9421F is a single-chip electronic volume IC incorporating an op amp circuit developed for car stereos.

With a few external parts, TC9421F can control a wide range of audio functions, including main volume, balance, fader, bass, treble, loudness, and input switching.

FEATURES

- Main volume : Offers 63 positions of separate left and right control over the range 0~78dB and ∞ (in 1~2dB / steps).
- Fader volume : Incorporates four sets of front (left and right) and rear (left and right) fader units for a range of 0~60dB and ∞ (16 positions)
- Tone control : ± 12 dB for both bass and treble (13 positions)
- Input selector : Any of four input signals can be amplified with any of four gain options : 0, 6, 10, or 12dB
- Incorporates op amp circuit, reducing external parts.
- Incorporates an interface for a 5V-system microcomputer.
- The Si-gate process realizes a high-performance volume system.

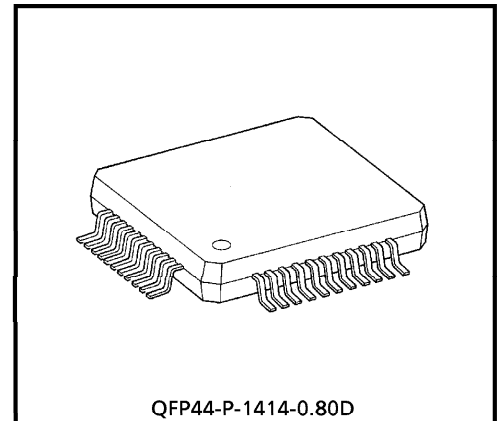

QFP44-P-1414-0.80D

Weight : 1.1g (Typ.)

PIN CONNECTION

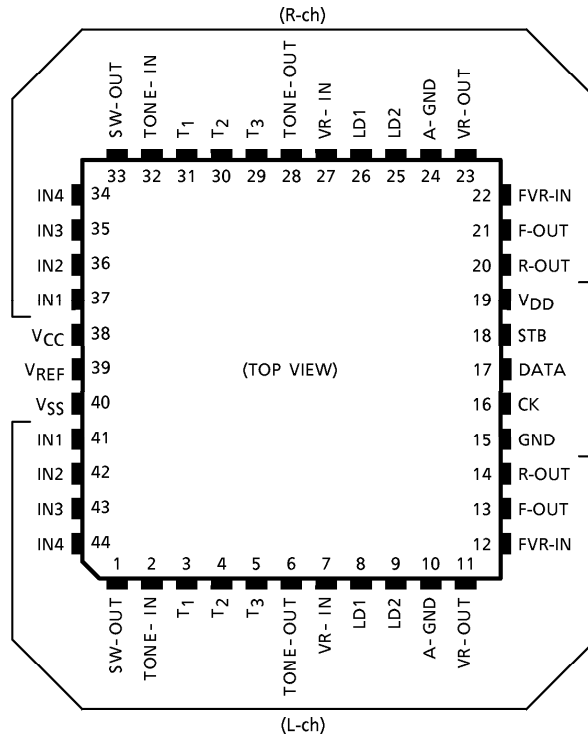

BLOCK DIAGRAM

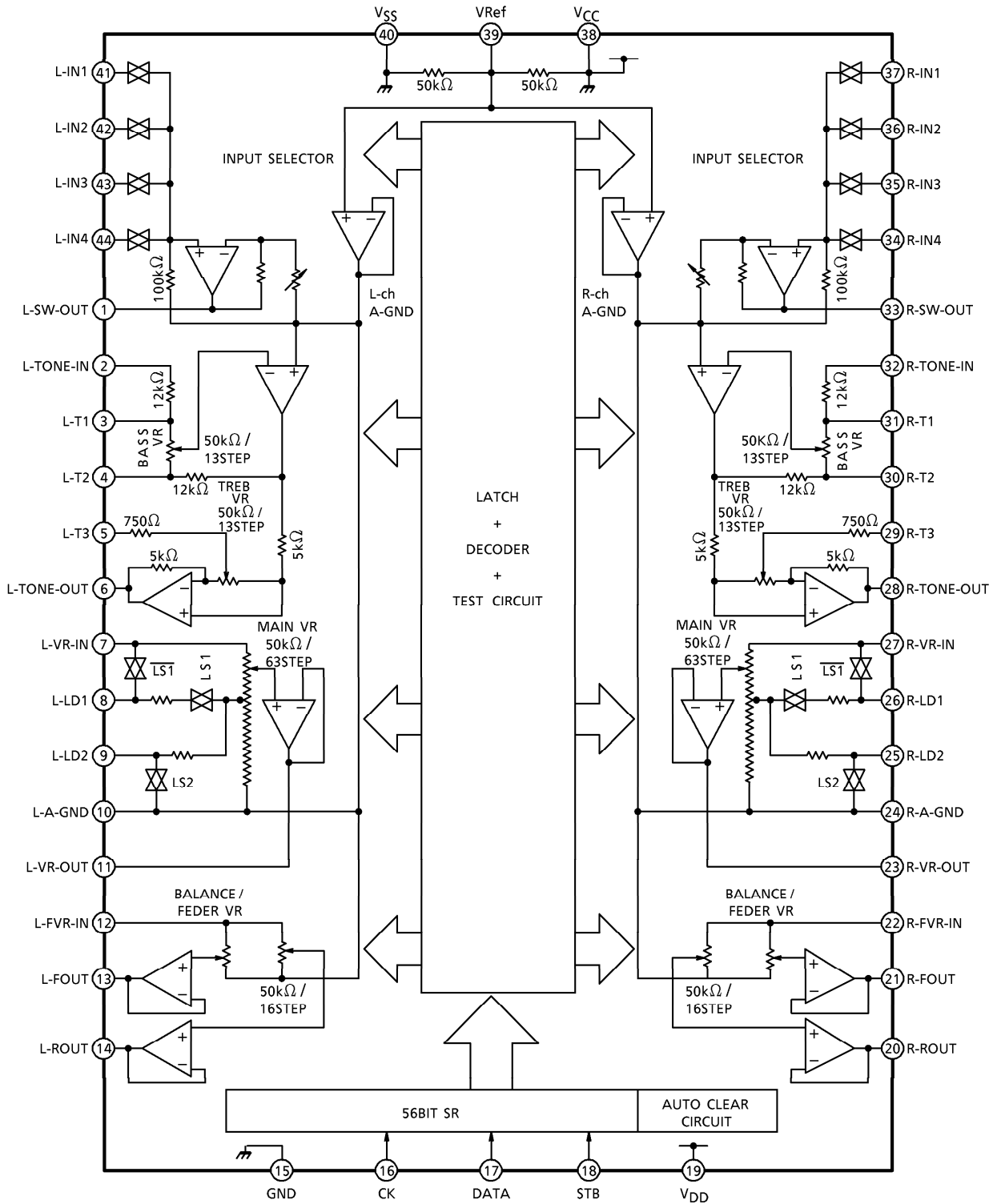

DESCRIPTION OF PINS

PIN No.	SYMBOL	PIN NAME	FUNCTION AND OPERATION	REMARKS		
41	L-IN1	Audio signal input pins	<ul style="list-style-type: none"> • Four input selector circuits • Input switches can be controlled independently • Op amp circuit gain can be set to 0dB, 6dB, 10dB, or 12dB 	—		
42	L-IN2					
43	L-IN3					
44	L-IN4					
37	R-IN1					
36	R-IN2					
35	R-IN3					
34	R-IN4					
1	L-SW-OUT	Input selector output pins				
33	R-SW-OUT					
2	L-TONE-IN	Tone circuit input pins	<ul style="list-style-type: none"> • Tone control circuit • Insert bass control capacitor between T₁ and T₂ • Insert treble control capacitor between T₁ (T₂) and T₃ • Supports 13-position control (± 12dB Typ.) 	—		
32	R-TONE-IN					
3	L-T ₁	Capacitor connection pins				
4	L-T ₂					
5	L-T ₃					
31	R-T ₁					
30	R-T ₂					
29	R-T ₃					
6	L-TONE-OUT	Tone circuit output pins				
28	R-TONE-OUT					
7	L-VR-IN	Main volume input pins	<ul style="list-style-type: none"> • Main volume circuit • 63-position control : 0~44dB (1dB / steps), 44~78dB (2dB / steps) and ∞ • Balance control based on independent control of left and right channels • Loudness control enabled by connecting capacitor to LD1 and LD2 	—		
27	R-VR-IN					
8	L-LD1	Loudness pins				
9	L-LD2					
26	R-LD1					
25	R-LD2					
11	L-VR-OUT	Main volume output pins				
23	R-VR-OUT					
10	L-A-GND	Analog ground pins			<ul style="list-style-type: none"> • Internal op amp reference voltage pins • Insert capacitor between these pins and GND 	—
24	R-A-GND					
12	L-FVR-IN	Fader volume input pins	<ul style="list-style-type: none"> • Fader volume circuit • 16-position control from 0~60dB and ∞ • Sound volume can be controlled individually for left front, left rear, right front, and right rear 	—		
22	R-FVR-IN					
13	L-F-OUT	Front output pins				
21	R-F-OUT					
14	L-R-OUT	Rear output pins				
20	R-R-OUT					

PIN No.	SYMBOL	PIN NAME	FUNCTION AND OPERATION	REMARKS
16	CK	Clock input pin	<ul style="list-style-type: none"> Serial data transfer clock input pin 	Low threshold value input pins
17	DATA	Data input pin	<ul style="list-style-type: none"> Control data input pin 	
18	STB	Strobe input pin	<ul style="list-style-type: none"> Data write strobe input pin 	
38	V _{CC}	Analog power supply pin	<ul style="list-style-type: none"> Use with V_{CC} = V_{DD} 	—
19	V _{DD}	Digital power supply pin		
40	V _{SS}	Analog ground pin	<ul style="list-style-type: none"> Ground pins 	—
15	GND	Digital ground pin		
39	V _{REF}	Reference voltage input pin	<ul style="list-style-type: none"> Used to determine internal op amp reference voltage (A-GND) Incorporates resistor for dividing voltage between V_{DD} and V_{SS} (Typ. V_{REF} = V_{DD} / 2) 	—

OPERATION

1. Volume data setting

Set volume using serial data input from the CK, DATA, and STB pins. Volume data contain 56 bits.

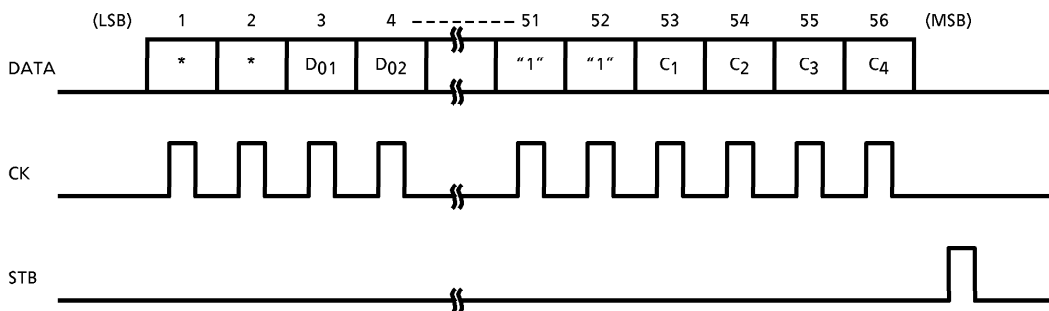

1) Volume control data assignment (* : Can be omitted)

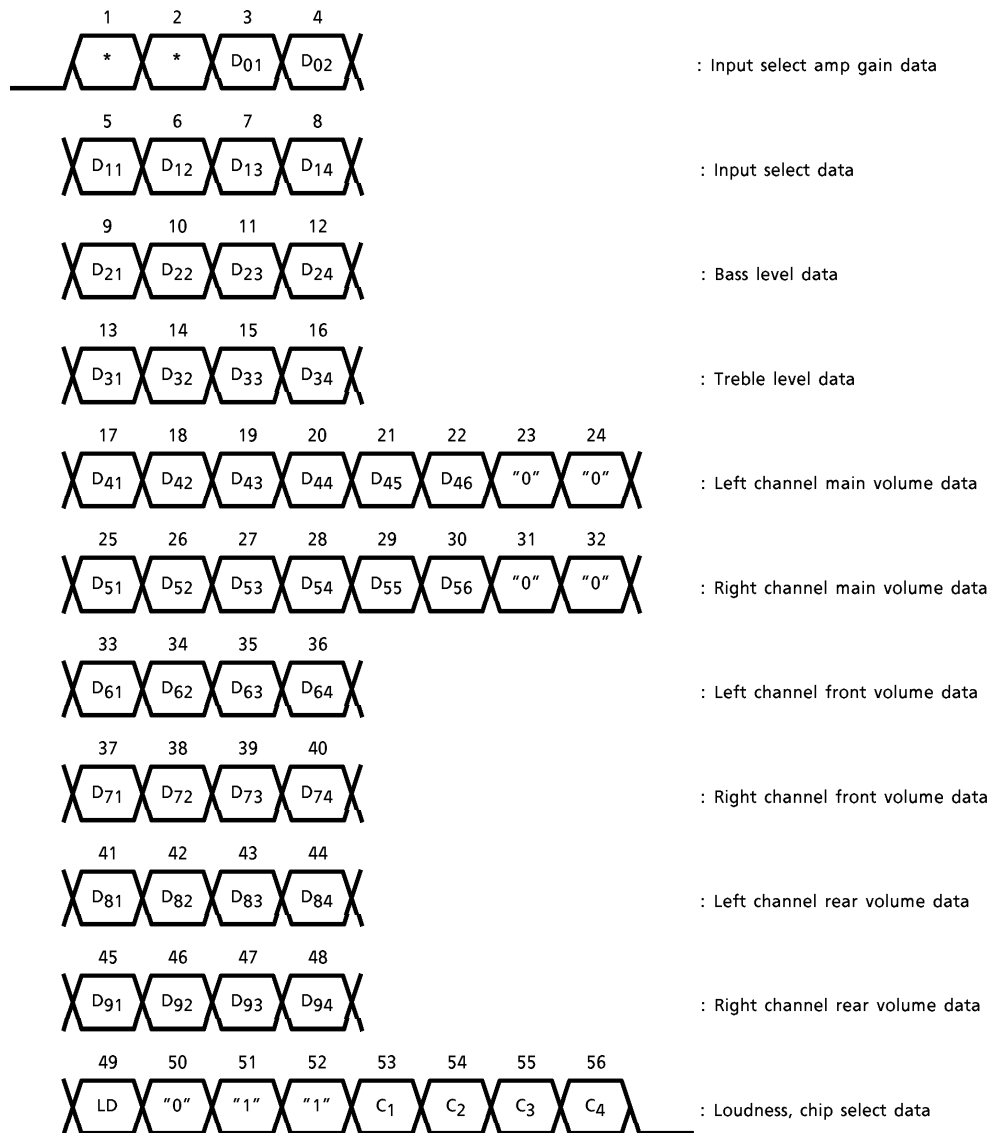

2) Chip select data (C₁~C₄)

Chip select code to enable serial data line to be shared with other ICs.

For TC9421F, set C₁ = "1", C₂ = C₃ = "0", C₄ = "1" (1001 : 9H).

2. Input select circuit

1) Equivalent circuit

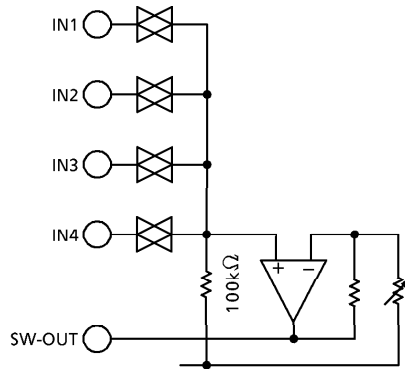

2) Input select and gain settings

- Gain setting

D01	D02	GAIN
0	0	0dB
1	0	6dB
0	1	10dB
1	1	12dB

- Input select settings

D11	D12	D13	D14	SW ₁	SW ₂	SW ₃	SW ₄
0	0	0	0	OFF	OFF	OFF	OFF
1	—	—	—	ON	—	—	—
—	1	—	—	—	ON	—	—
—	—	1	—	—	—	ON	—
—	—	—	1	—	—	—	ON

(*) If turning on two or more among switches SW₁~SW₄ at the same time, connect 10kΩ or higher to the input pins (IN1~IN4).

3. Tone control circuit

1) Equivalent circuit

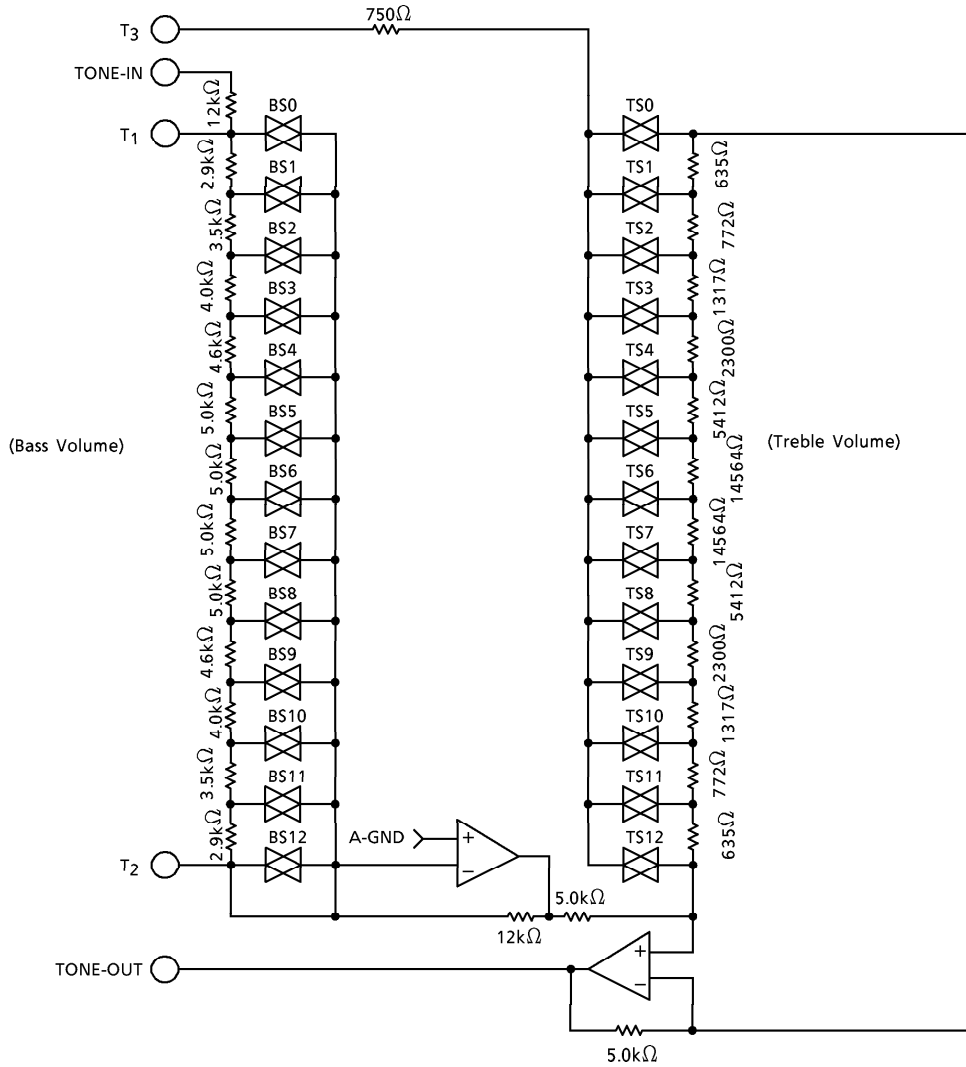

2) Bass and treble level settings

● Bass level settings

D21	D22	D23	D24	VOLUME VALUE
0	1	1	0	+ 12dB
1	0	1	0	+ 10dB
0	0	1	0	+ 8dB
1	1	0	0	+ 6dB
0	1	0	0	+ 4dB
1	0	0	0	+ 2dB
0	0	0	0	0dB
1	1	1	1	- 2dB
0	1	1	1	- 4dB
1	0	1	1	- 6dB
0	0	1	1	- 8dB
1	1	0	1	- 10dB
0	1	0	1	- 12dB

● Treble level settings

D31	D32	D33	D34	VOLUME VALUE
0	1	1	0	+ 12dB
1	0	1	0	+ 10dB
0	0	1	0	+ 8dB
1	1	0	0	+ 6dB
0	1	0	0	+ 4dB
1	0	0	0	+ 2dB
0	0	0	0	0dB
1	1	1	1	- 2dB
0	1	1	1	- 4dB
1	0	1	1	- 6dB
0	0	1	1	- 8dB
1	1	0	1	- 10dB
0	1	0	1	- 12dB

4. Main volume circuit

1) Equivalent circuit

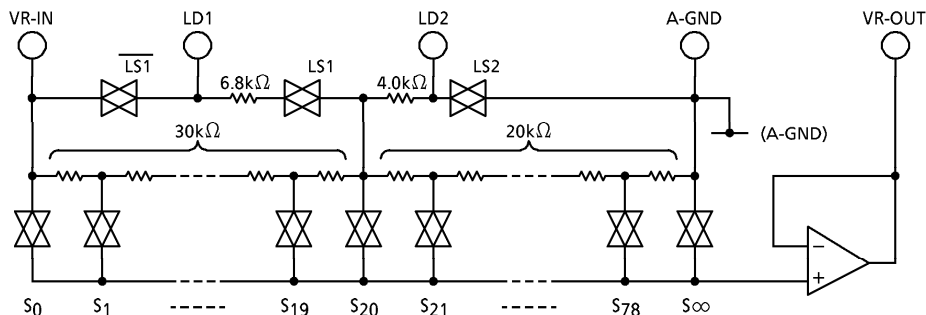

- The loudness pin is connected to a 20dB tap.
- When the loudness is ON : LS1 = ON, $\overline{LS1}$ = OFF, LS2 = OFF
 When the loudness is OFF : LS1 = OFF, $\overline{LS1}$ = ON, LS2 = ON

2) Main volume settings

VOLUME VALUE	D	D	D	D	D	D	VOLUME VALUE	D	D	D	D	D	D	VOLUME VALUE	D	D	D	D	D	D	VOLUME VALUE	D	D	D	D	D	D
	41	42	43	44	45	46		41	42	43	44	45	46		41	42	43	44	45	46		41	42	43	44	45	46
0dB	0	0	0	0	0	0	16dB	0	0	0	0	1	0	32dB	0	0	0	0	0	1	52dB	0	0	0	0	1	1
1dB	1	0	0	0	0	0	17dB	1	0	0	0	1	0	33dB	1	0	0	0	0	1	54dB	1	0	0	0	1	1
2dB	0	1	0	0	0	0	18dB	0	1	0	0	1	0	34dB	0	1	0	0	0	1	56dB	0	1	0	0	1	1
3dB	1	1	0	0	0	0	19dB	1	1	0	0	1	0	35dB	1	1	0	0	0	1	58dB	1	1	0	0	1	1
4dB	0	0	1	0	0	0	20dB	0	0	1	0	1	0	36dB	0	0	1	0	0	1	60dB	0	0	1	0	1	1
5dB	1	0	1	0	0	0	21dB	1	0	1	0	1	0	37dB	1	0	1	0	0	1	62dB	1	0	1	0	1	1
6dB	0	1	1	0	0	0	22dB	0	1	1	0	1	0	38dB	0	1	1	0	0	1	64dB	0	1	1	0	1	1
7dB	1	1	1	0	0	0	23dB	1	1	1	0	1	0	39dB	1	1	1	0	0	1	66dB	1	1	1	0	1	1
8dB	0	0	0	1	0	0	24dB	0	0	0	1	1	0	40dB	0	0	0	1	0	1	68dB	0	0	0	1	1	1
9dB	1	0	0	1	0	0	25dB	1	0	0	1	1	0	41dB	1	0	0	1	0	1	70dB	1	0	0	1	1	1
10dB	0	1	0	1	0	0	26dB	0	1	0	1	1	0	42dB	0	1	0	1	0	1	72dB	0	1	0	1	1	1
11dB	1	1	0	1	0	0	27dB	1	1	0	1	1	0	43dB	1	1	0	1	0	1	74dB	1	1	0	1	1	1
12dB	0	0	1	1	0	0	28dB	0	0	1	1	1	0	44dB	0	0	1	1	0	1	76dB	0	0	1	1	1	1
13dB	1	0	1	1	0	0	29dB	1	0	1	1	1	0	46dB	1	0	1	1	0	1	78dB	1	0	1	1	1	1
14dB	0	1	1	1	0	0	30dB	0	1	1	1	1	0	48dB	0	1	1	1	0	1	∞dB	0	1	1	1	1	1
15dB	1	1	1	1	0	0	31dB	1	1	1	1	1	0	50dB	1	1	1	1	0	1							

5. Fader volume circuit

1) Equivalent circuit

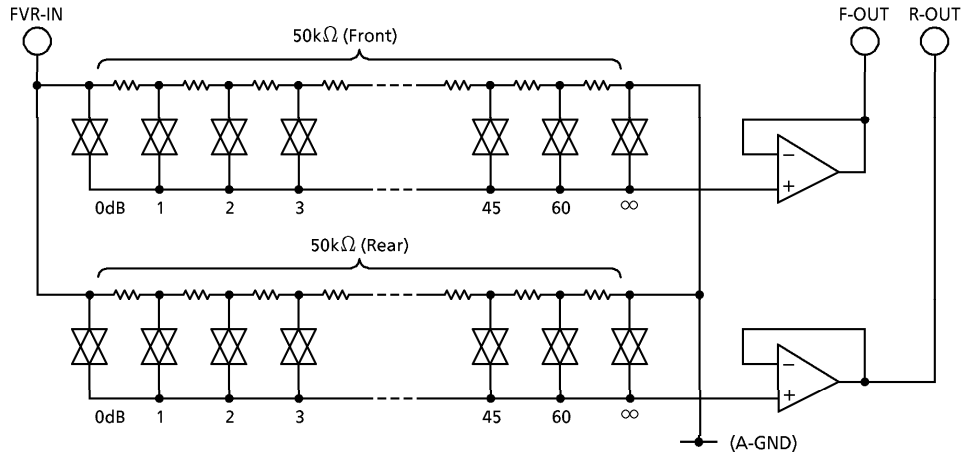

2) Fader volume setting

• Front volume setting

VOLUME VALUE	D61	D62	D63	D64
	D71	D72	D73	D74
0dB	0	0	0	0
1dB	1	0	0	0
2dB	0	1	0	0
3dB	1	1	0	0
4dB	0	0	1	0
6dB	1	0	1	0
8dB	0	1	1	0
10dB	1	1	1	0
12dB	0	0	0	1
14dB	1	0	0	1
16dB	0	1	0	1
20dB	1	1	0	1
30dB	0	0	1	1
45dB	1	0	1	1
60dB	0	1	1	1
∞ dB	1	1	1	1

• Rear volume setting

VOLUME VALUE	D81	D82	D83	D84
	D91	D92	D93	D94
0dB	0	0	0	0
1dB	1	0	0	0
2dB	0	1	0	0
3dB	1	1	0	0
4dB	0	0	1	0
6dB	1	0	1	0
8dB	0	1	1	0
10dB	1	1	1	0
12dB	0	0	0	1
14dB	1	0	0	1
16dB	0	1	0	1
20dB	1	1	0	1
30dB	0	0	1	1
45dB	1	0	1	1
60dB	0	1	1	1
∞ dB	1	1	1	1

MAXIMUM RATINGS (Ta = 25°C)

CHARACTERISTIC	SYMBOL	RATING	UNIT
Supply Voltage	V _{DD} /V _{CC}	-0.3~15	V
Input Voltage	V _{IN}	-0.3~V _{DD} /V _{CC} +0.3	V
Power Dissipation	P _D	300	mW
Operating Temperature	T _{opr}	-40~85	°C
Storage Temperature	T _{stg}	-65~150	°C

ELECTRICAL SPECIFICATIONS (Unless otherwise specified, Ta = 25°C, V_{DD} = V_{CC} = 9.0V)

CHARACTERISTIC	SYMBOL	TEST CIR-CUIT	TEST CONDITION	MIN.	TYP.	MAX.	UNIT	
Operating Supply Voltage	V _{DD} /V _{CC}	—	Ta = -40~85°C	6.0	9.0	12.0	V	
Operating Supply Current	I _{CC} +I _{DD}	1	No input, no load	—	15.0	30.0	mA	
Input Voltage	"H" Level	V _{IH}	CK, DATA, STB pins V _{DD} = 6.0~12V	4.0	~	V _{DD}	V	
	"L" Level	V _{IL}		0	~	1.0		
Input Current	"H" Level	I _{IH}		V _{IH} = V _{DD}	-1.0	~	1.0	μA
	"L" Level	I _{IL}		V _{IL} = 0V	-1.0	~	1.0	
Volume Control Resistance	R _{VR}	—	Main volume, LD = OFF	35	50	65	kΩ	
	R _{TO}		Tone volume	35	50	65		
	R _{FD}		Fader volume	35	50	65		
Input Resistance	R _{IN}	—	IN1~IN4 input resistance	21	30	39		
Setup Time	t _{SET}	2	CK, DATA, STB signals	1.0	—	—	μs	
Data Hold Time	t _{HOLD}			1.0	—	—		
Input Pulse Width	t _W			1.0	—	—		
Operating Frequency	f _{OP}			—	—	500		kHz

● Input selector block

Maximum Input Level	V _{INMAX}	—	f _{IN} = 1kHz, G _V = 0dB THD = 1%, R _L = 12kΩ	—	2.0	—	V _{rms}	
Input Gain	G _{V1}		f _{IN} = 1kHz R _g = 600Ω	G _V = 0dB	-1.5	0	1.5	dB
	G _{V2}		G _V = 6dB	4.5	6	7.5		
	G _{V3}		G _V = 10dB	8.5	10	11.5		
	G _{V4}		G _V = 12dB	10.5	12	13.5		

● Main volume block

Step Resolution	ΔSTEP	—	0dB~44dB	0.5	1	1.5	dB
			44dB~78dB	1	2	3	
Output Load Resistance	R _L	—	VR-OUT pins	12	25	—	kΩ

● Tone control block

CHARACTERISTIC	SYMBOL	TEST CIR-CUIT	TEST CONDITIONS	MIN.	TYP.	MAX.	UNIT
Control Range	G_{VT}	—	Maximum boost / cut	± 10	± 12	± 15	dB
Step Resolution	$\Delta STEP$		—	1	2	3	
Output Load Resistance	R_L		TONE-OUT pin	12	50	—	k Ω

● Fader volume block

Step Resolution	$\Delta STEP$	—	0dB~4dB	0.5	1.0	1.5	dB
			4dB~16dB	1	2	3	
Output Load Resistance	R_L		F-OUT / R-OUT pins	12	33	—	k Ω

● Overall characteristics

Overall Harmonic Distortion Ratio	THD (1)	1	$V_{IN} = 300mV_{rms}$ All set to flat $R_g = 600\Omega$ $R_L = 33k\Omega$	$f_{IN} = 1kHz$	—	0.005	0.01	%
	THD (2)			$f_{IN} = 20kHz$	—	0.008	0.02	
Crosstalk	TC		$V_{IN} = 1V_{rms}$, $R_g = 600\Omega$ $f_{IN} = 1kHz$, All set to flat	60	80	—	dB	
Maximum Attenuation	AT_{MAX}		$V_{IN} = 1V_{rms}$, $f_{IN} = 1kHz$ $R_L = 33k\Omega$, Main volume ∞	60	80	—	dB	
Output Noise Voltage	$V_N (1)$		$R_g = 600\Omega$ (IHF-A) All set to flat	—	5.0	12.0	μV_{rms}	
	$V_N (2)$	$R_g = 600\Omega$ (IHF-A) Bass / treble set to maximum boost Input amp set to +12dB	—	5.0	120			

Test circuit 1 : Application circuit example used

Test circuit 2 : Serial data timing

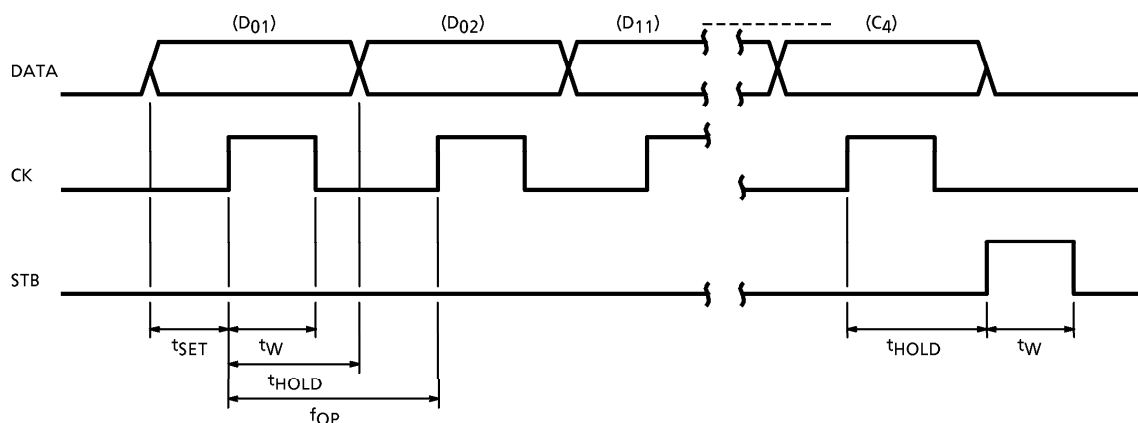

APPLICATION CIRCUIT

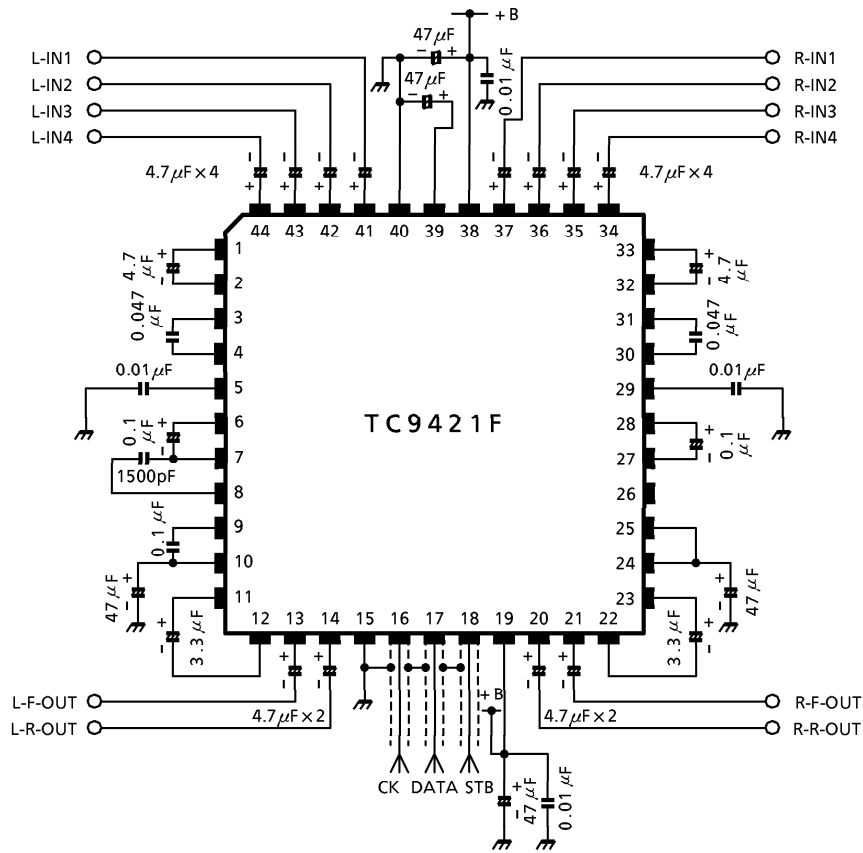

- The circuit example shows the left channel with loudness control and the right channel with no loudness control.

(Note) As the CK, DATA, and STB pins receive microcontroller communication digital signals, take measures to prevent digital signals leaking to analog circuits, thus causing noise. For example, use a ground pattern to guard the pins or use a shielded line.

PACKAGE DIMENSIONS
QFP44-P-1414-0.80D

Unit : mm

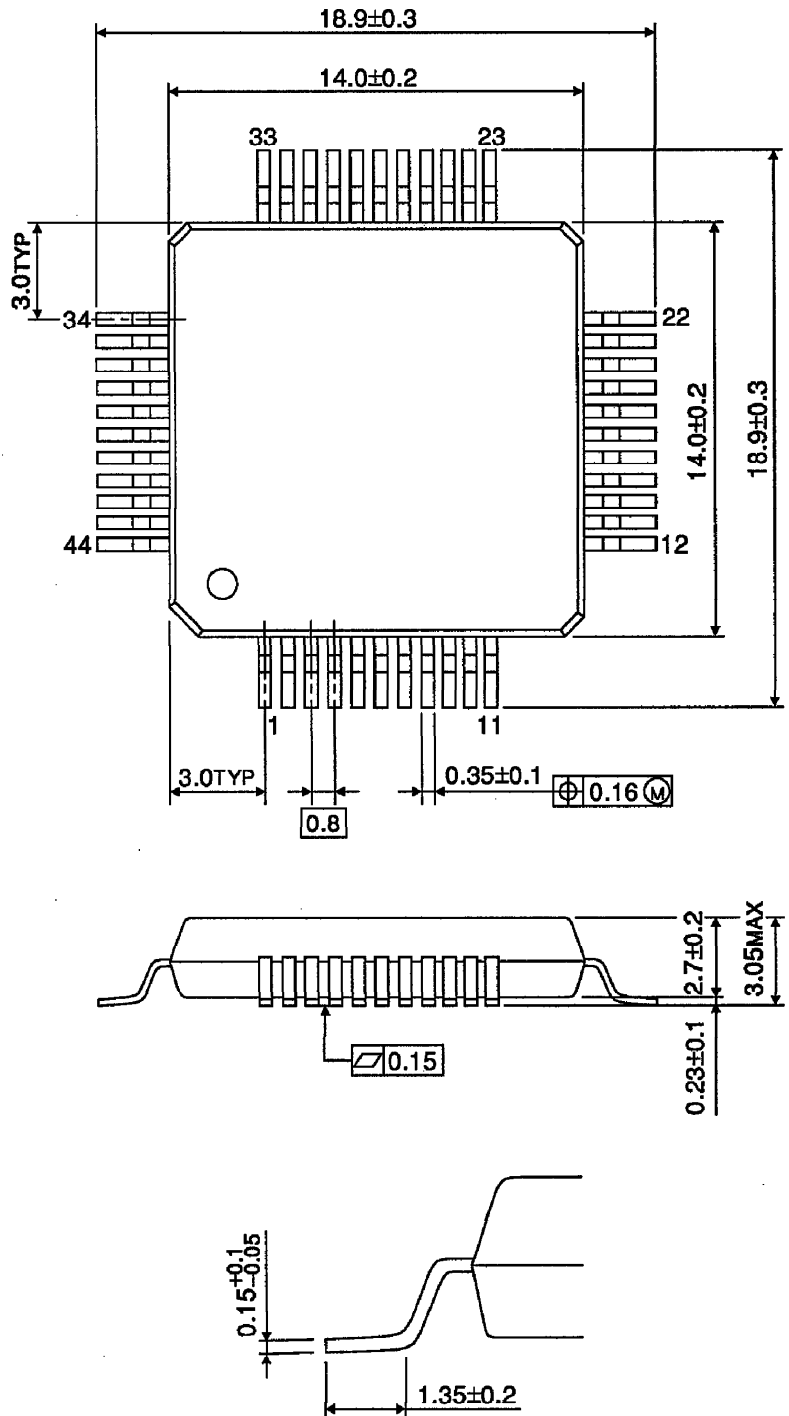

Weight : 1.1g (Typ.)

RESTRICTIONS ON PRODUCT USE

000707EBA

- TOSHIBA is continually working to improve the quality and reliability of its products. Nevertheless, semiconductor devices in general can malfunction or fail due to their inherent electrical sensitivity and vulnerability to physical stress. It is the responsibility of the buyer, when utilizing TOSHIBA products, to comply with the standards of safety in making a safe design for the entire system, and to avoid situations in which a malfunction or failure of such TOSHIBA products could cause loss of human life, bodily injury or damage to property. In developing your designs, please ensure that TOSHIBA products are used within specified operating ranges as set forth in the most recent TOSHIBA products specifications. Also, please keep in mind the precautions and conditions set forth in the "Handling Guide for Semiconductor Devices," or "TOSHIBA Semiconductor Reliability Handbook" etc..
- The TOSHIBA products listed in this document are intended for usage in general electronics applications (computer, personal equipment, office equipment, measuring equipment, industrial robotics, domestic appliances, etc.). These TOSHIBA products are neither intended nor warranted for usage in equipment that requires extraordinarily high quality and/or reliability or a malfunction or failure of which may cause loss of human life or bodily injury ("Unintended Usage"). Unintended Usage include atomic energy control instruments, airplane or spaceship instruments, transportation instruments, traffic signal instruments, combustion control instruments, medical instruments, all types of safety devices, etc.. Unintended Usage of TOSHIBA products listed in this document shall be made at the customer's own risk.
- The products described in this document are subject to the foreign exchange and foreign trade laws.
- The information contained herein is presented only as a guide for the applications of our products. No responsibility is assumed by TOSHIBA CORPORATION for any infringements of intellectual property or other rights of the third parties which may result from its use. No license is granted by implication or otherwise under any intellectual property or other rights of TOSHIBA CORPORATION or others.
- The information contained herein is subject to change without notice.