

DP8216/DP8216M/DP8226/DP8226M 4-Bit Bidirectional Bus Transceivers

General Description

The DP8216/DP8216M and DP8226/DP8226M are 4-bit bidirectional bus drivers to use in bus oriented applications. The non-inverting DP8216/DP8216M and inverting DP8226/DP8226M drivers are provided for flexibility in system design.

Each buffered line of the four-bit drivers consists of two separate buffers that are TRI-STATE® to achieve direct bus interface and bidirectional capability. On one side of the driver the output of one buffer and the input of another are tied together (DB); this side is used to interface to the system side components such as memories, I/O, etc., because its interface is TTL compatible and it has high driver (50 mA). On the other side of the driver the inputs and outputs are separated to provide maximum flexibility. Of course, they can be tied together so that the driver can be used to buffer a true bidirectional bus. The DO outputs on this side of the driver have a special high voltage output drive capability so that direct interface to the 8080 type CPUs is achieved with an adequate amount of noise immunity.

The CS input is a device enable. When it is "high" the output drivers are all forced to their high-impedance state. When it is a "low" the device is enabled and the direction of the data flow is determined by the DIEN input.

The DIEN input controls the direction of data flow, which is accomplished by forcing one of the pair of buffers into its high-impedance state and allowing the other to transmit its data. A simple two-gate circuit is used for this function.

Features

- Data bus buffer driver to 8080 type CPUs
- Low input load current—0.25 mA maximum
- High output drive capability for driving system data bus—50 mA at 0.5V
- Power up-down protection
- DP8216/DP8216M have non-inverting outputs
- DP8226/DP8226M have inverting outputs
- Output high voltage compatible with direct interface to MOS
- TRI-STATE outputs
- Advanced Schottky processing
- Available in military and commercial temperature

Logic Diagrams

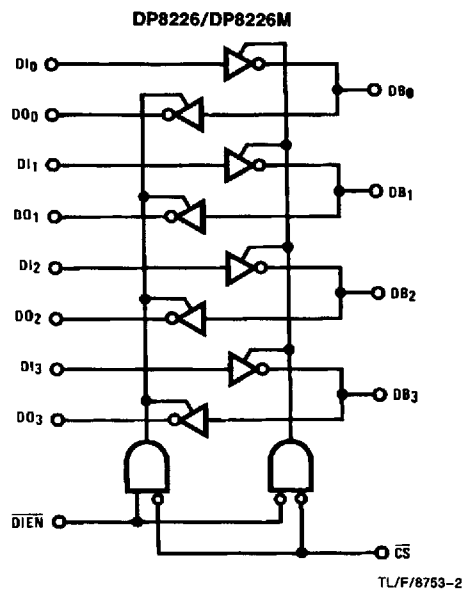
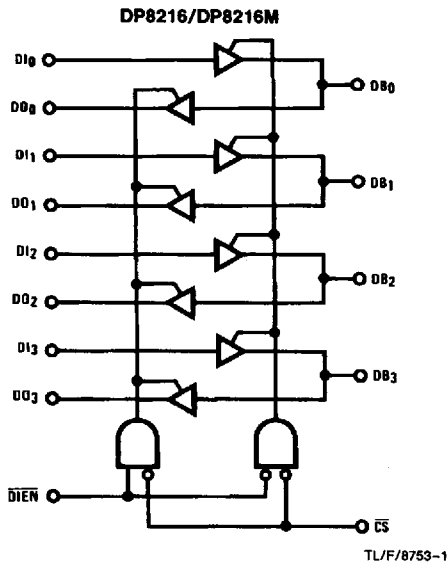

TRI-STATE® is a registered trademark of National Semiconductor Corp.

Absolute Maximum Ratings (Note 1)

If Military/Aerospace specified devices are required, please contact the National Semiconductor Sales Office/Distributors for availability and specifications.

	Min	Max	Units
All Output and Supply Voltages	-0.5	+7.0	V
All Input Voltages	-1.0	+5.5	V
Output Currents		125	mA
Maximum Power Dissipation* at 25°C			
Cavity Package		1509	mW
Molded Package		1476	mW

Note: *Derate cavity package 10.1 mW/°C above 25°C; derate molded package 11.8 mW/°C above 25°C.

	Min	Max	Units
Storage Temperature	-65	+150	°C
Lead Temperature (soldering, 4 seconds)		260	°C

Operating Conditions

	Min	Max	Units
Supply Voltage, V _{CC}			
DP8216M, DP8226M	4.5	5.5	V
DP8216, DP8226	4.75	5.25	V
Temperature, T _A			
DP8216M, DP8226M	-55	+125	°C
DP8216, DP8226	0	+70	°C

Electrical Characteristics DP8216, DP8226 V_{CC} = 5V ± 5% (Notes 2, 3, and 4)

Symbol	Parameter	Conditions	Limits			Units
			Min	Typ	Max	
DRIVERS						
V _{IL}	Input Low Voltage				0.95	V
V _{IH}	Input High Voltage		2			V
I _F	Input Load Current	V _F = 0.45V		-0.03	-0.25	mA
I _R	Input Leakage Current	V _R = 5.25V			10	μA
V _C	Input Clamp Voltage	I _C = -5 mA			-1.2	V
V _{OL1}	Output Low Voltage	I _{OL} = 25 mA		0.3	0.45	V
V _{OL2}	Output Low Voltage	DP8216 I _{OL} = 55 mA DP8226 I _{OL} = 50 mA		0.5	0.6	V
V _{OH}	Output High Voltage	I _{OH} = -10 mA	2.4	3.0		V
I _{SC}	Output Short Circuit Current	V _{CC} = 5V	-30	-75	-120	mA
I _O	Output Leakage Current TRI-STATE	V _O = 0.45V/5.5V			100	μA
RECEIVERS						
V _{IL}	Input Low Voltage				0.95	V
V _{IH}	Input High Voltage		2			V
I _F	Input Load Current	V _F = 0.45V		-0.08	-0.25	mA
V _C	Input Clamp Voltage	I _C = -5 mA			-1.2	V
V _{OL}	Output Low Voltage	I _{OL} = 15 mA		0.3	0.45	V
V _{OH1}	Output High Voltage	I _{OH} = -1 mA	3.65	4.0		V
I _{SC}	Output Short Circuit Current	V _{CC} = 5V	-15	-35	-65	mA
I _O	Output Leakage Current TRI-STATE	V _O = 0.45V/5.5V			20	μA
CONTROL INPUTS (CS̄, DIEN̄)						
V _{IL}	Input Low Voltage				0.95	V
V _{IH}	Input High Voltage		2			V
I _F	Input Load Current	V _F = 0.45V		-0.15	-0.5	mA
I _R	Input Leakage Current	V _R = 5.25V			20	μA
I _{CC}	Power Supply Current					
	DP8216			95	130	mA
	DP8226			85	120	mA

Electrical Characteristics (Continued) DP8216M, DP8226M $V_{CC} = 5V \pm 10\%$ (Notes 2, 3 and 4)

Symbol	Parameter	Conditions	Limits			Units
			Min	Typ	Max	
DRIVERS						
V_{IL}	Input Low Voltage DP8216M DP8226M				0.95 0.90	V V
V_{IH}	Input High Voltage		2			V
I_F	Input Load Current	$V_F = 0.45V$		-0.08	-0.25	mA
I_R	Input Leakage Current	$V_R = 5.5V$			40	μA
V_C	Input Clamp Voltage	$I_C = -5 mA$			-1.2	V
V_{OL1}	Output Low Voltage	$I_{OL} = 25 mA$		0.3	0.45	V
V_{OL2}	Output Low Voltage	$I_{OL} = 45 mA$		0.5	0.6	V
V_{OH}	Output High Voltage	$I_{OH} = -5 mA$	2.4	3.0		V
I_{SC}	Output Short Circuit Current	$V_{CC} = 5.0V$	-30	-75	-120	mA
$ I_{OL} $	Output Leakage Current TRI-STATE	$V_O = 0.45V/5.5V$			100	μA
RECEIVERS						
V_{IL}	Input Low Voltage DP8216M DP8226M				0.95 0.9	V V
V_{IH}	Input High Voltage		2			V
I_F	Input Load Current	$V_F = 0.45V$		-0.08	-0.25	mA
V_C	Input Clamp Voltage	$I_C = -5 mA$			-1.2	V
V_{OL}	Output Low Voltage	$I_{OL} = 15 mA$		0.3	0.45	V
V_{OH1}	Output High Voltage	$I_{OH} = -0.5 mA$	3.4	3.8		V
V_{OH2}	Output High Voltage	$I_{OH} = -2 mA$	2.4			V
I_{SC}	Output Short Circuit Current	$V_{CC} = 5.0V$	-15	-35	-65	mA
$ I_{OL} $	Output Leakage Current TRI-STATE	$V_O = 0.45V/5.5V$			20	μA
CONTROL INPUTS (CS, DIEN)						
V_{IL}	Input Low Voltage DP8216M DP8226M				0.95 0.9	V V
V_{IH}	Input High Voltage		2			V
I_F	Input Load Current	$V_F = 0.45V$		-0.15	-0.5	mA
I_R	Input Leakage Current	$V_R = 5.5V$			80	μA
I_{CC}	Power Supply Current DP8216M DP8226M			95 85	130 120	mA mA

Switching Characteristics (Notes 2, 3 and 4)

Symbol	Parameter	Conditions	Limits			Units
			Min	Typ	Max	
DP8216M, DP8226M, $V_{CC} = 5V \pm 10\%$						
t_{PD1}	Input to Output Delay, DO Outputs	$C_L = 30 \text{ pF}$, $R_1 = 300\Omega$, $R_2 = 600\Omega$		15	25	ns
t_{PD2}	Input to Output Delay, DB Outputs DP8216M DP8226M	$C_L = 300 \text{ pF}$, $R_1 = 90\Omega$, $R_2 = 180\Omega$		19	33	ns
				16	25	ns
t_E	Output Enable Time DP8216M DP8226M	DO Outputs: $C_L = 30 \text{ pF}$, $R_1 = 300\Omega$, $R_2 = 600\Omega$ DB Outputs: $C_L = 300 \text{ pF}$, $R_1 = 90\Omega$, $R_2 = 180\Omega$		42	75	ns
				36	62	ns
t_D	Output Disable Time DP8216M DP8226M	DO Outputs: $C_L = 5 \text{ pF}$, $R_1 = 300\Omega$, $R_2 = 600\Omega$ DB Outputs: $C_L = 5 \text{ pF}$, $R_1 = 90\Omega$, $R_2 = 180\Omega$		16	40	ns
				16	38	ns
DP8216, DP8226 $V_{CC} = 5.0V \pm 5\%$						
t_{PD1}	Input to Output Delay, DO Outputs	$C_L = 30 \text{ pF}$, $R_1 = 300\Omega$, $R_2 = 600\Omega$		15	25	ns
t_{PD2}	Input to Output Delay, DB Outputs DP8216 DP8226	$C_L = 300 \text{ pF}$, $R_1 = 90\Omega$, $R_2 = 180\Omega$		20	30	ns
				16	25	ns
t_E	Output Enable Time DP8216 DP8226	DO Outputs: $C_L = 30 \text{ pF}$, $R_1 = 300\Omega$, $R_2 = 600\Omega$ DB Outputs: $C_L = 300 \text{ pF}$, $R_1 = 90\Omega$, $R_2 = 180\Omega$		45	65	ns
				35	54	ns
t_D	Output Disable Time	DO Outputs: $C_L = 5 \text{ pF}$, $R_1 = 300\Omega$, $R_2 = 600\Omega$ DB Outputs: $C_L = 5 \text{ pF}$, $R_1 = 90\Omega$, $R_2 = 180\Omega$		20	35	ns

Note 1: "Absolute Maximum Ratings" are those values beyond which the safety of the device cannot be guaranteed. They are not meant to imply that the devices should be operated at these limits. The tables of "Electrical Characteristics" provide conditions for actual device operation.

Note 2: Unless otherwise specified, min/max limits apply across the -55°C to $+125^\circ\text{C}$ temperature range for the DP8216M and DP8226M and across the 0°C to $+70^\circ\text{C}$ temperature range for the DP8216 and DP8226. All typical values are given for $V_{CC} = 5V$ and $T_A = 25^\circ\text{C}$.

Note 3: All currents into device pins are positive; all currents out of device pins are negative. All voltages are referenced to ground unless otherwise specified.

Note 4: Only one output at a time should be shorted.

Test Conditions

Input rise and fall times of 5.0 ns between 1.0V and 2.0V.
 Output loading is 5.0 mA and 10 pF.
 Speed measurements are made at 1.5V levels.

Test Load Circuit

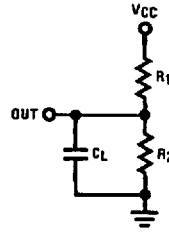

TL/F/8753-4

Switching Time Waveforms

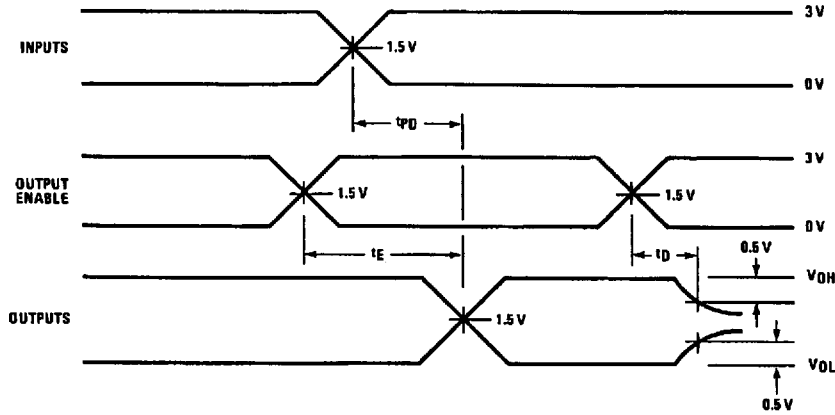

TL/F/8753-5

Connection Diagram

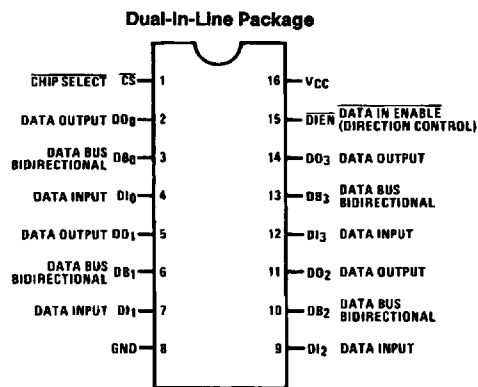

TL/F/8753-3

Order Number DP8216J, DP8216N, DP8226J, DP8226N,
 DP8216MJ or DP8226MJ
 See NS Package Number J16A or N16A

Capacitance $T_A = 25^\circ\text{C}$

Symbol	Parameter	Limit			Unit
		Min	Typ	Min	
C_{IN}	Input Capacitance		4	6	pF
C_{OUT}	Output Capacitance DO Outputs		6	10	pF
			13	18	

Note: This parameter is periodically sampled and is not 100% tested. Condition of measurement is $f = 1 \text{ MHz}$, $V_{BIAS} = 2.5\text{V}$, $V_{CC} = 5.0\text{V}$, and $T_A = 25^\circ\text{C}$.

Physical Dimensions inches (millimeters)

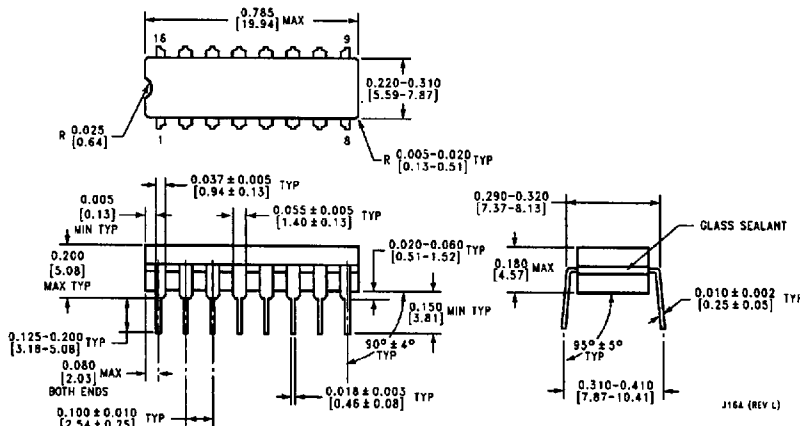

Ceramic Dual-In-Line Package (J)
Order Number DP8216J, DP8226J, DP8216MJ or DP8226MJ
NS Package Number J16A

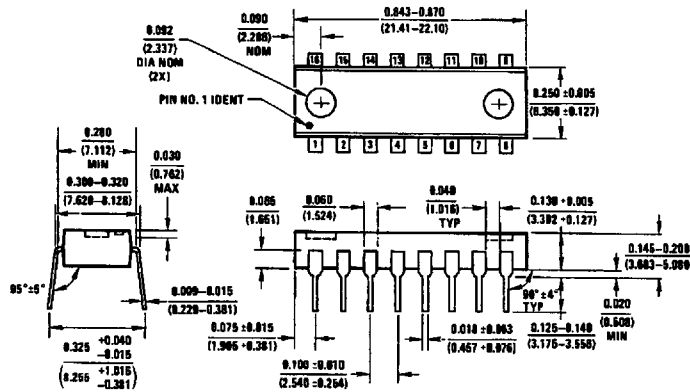

Molded Dual-In-Line Package (N)
Order Number DP8216N, or DP8226N
NS Package Number N16A

LIFE SUPPORT POLICY

NATIONAL'S PRODUCTS ARE NOT AUTHORIZED FOR USE AS CRITICAL COMPONENTS IN LIFE SUPPORT DEVICES OR SYSTEMS WITHOUT THE EXPRESS WRITTEN APPROVAL OF THE PRESIDENT OF NATIONAL SEMICONDUCTOR CORPORATION. As used herein:

1. Life support devices or systems are devices or systems which, (a) are intended for surgical implant into the body, or (b) support or sustain life, and whose failure to perform, when properly used in accordance with instructions for use provided in the labeling, can be reasonably expected to result in a significant injury to the user.
2. A critical component is any component of a life support device or system whose failure to perform can be reasonably expected to cause the failure of the life support device or system, or to affect its safety or effectiveness.



National Semiconductor Corporation
 1111 West Bardin Road
 Arlington, TX 76017
 Tel: 1(800) 272-9959
 Fax: 1(800) 737-7018

National Semiconductor Europe
 Fax: (+49) 0-180-530 85 86
 Email: cnjwge@tevm2.nsc.com
 Deutsch Tel: (+49) 0-180-530 85 85
 English Tel: (+49) 0-180-532 78 32
 Français Tel: (+49) 0-180-532 93 58
 Italiano Tel: (+49) 0-180-534 16 80

National Semiconductor Hong Kong Ltd.
 19th Floor, Straight Block,
 Ocean Centre, 5 Canton Rd.
 Tsimshatsui, Kowloon
 Hong Kong
 Tel: (852) 2737-1600
 Fax: (852) 2736-9960

National Semiconductor Japan Ltd.
 Tel: 81-043-289-2309
 Fax: 81-043-289-2408

National does not assume any responsibility for use of any circuitry described, no circuit patent licenses are implied and National reserves the right at any time without notice to change said circuitry and specifications.

6