

FEATURES

- 25 dB Gain
- 40 MHz to 1 GHz Operating Range
- 0.5 dB Gain Flatness
- 24 V Supply
- Supply Current: 430 mA (Typ.)
- Very Low Distortion & Noise
- Robust Design and Insensitive to Voltage Transients
- GaAs Monolithic IC-Based
- Standard SOT-115J Package
- Ruggedized design with integrated ring wave surge protection
- Superior ESD protection, >7kV

APPLICATIONS

- Distribution Nodes, System Amplifiers, and Line Extenders in CATV Systems

PRODUCT DESCRIPTION

The ACA2786 is a GaAs Hybrid Amplifier for CATV HFC distribution systems. It consists of two pairs of parallel amplifiers that are optimized for exceptionally low distortion and noise figure with input and output transient voltage protection. The ACA2786 is offered in a standard SOT-115J package.

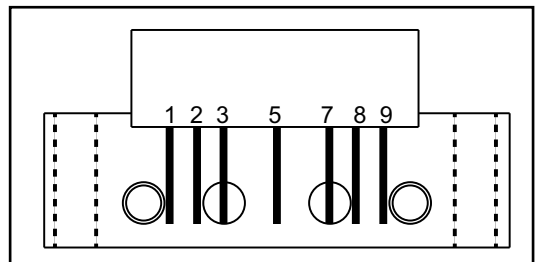
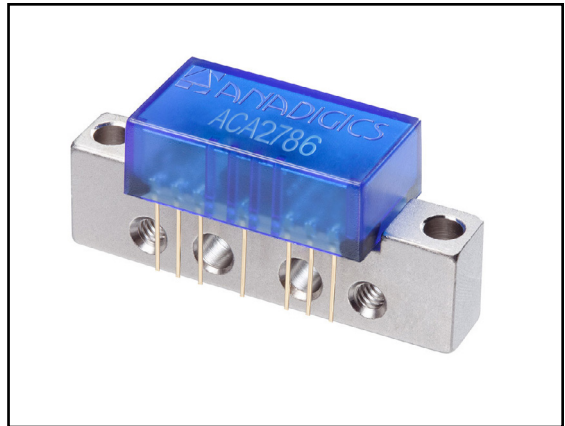

Figure 2: Hybrid Pinout

Table 1: SOT-115J Pinning

PIN	Description
1	RF Input
2	GND
3	GND or No Connection
5	24 V
7, 8	GND
9	RF Output

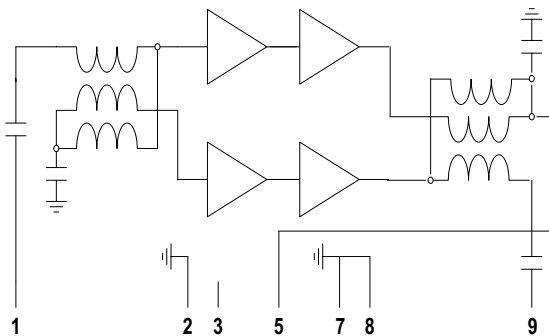

Figure 1: Simplified Hybrid Internal Arrangement

Table 2: Absolute Minimum and Maximum Ratings

	Symbol	Min	Typ	Max	Unit	Conditions
Supply Voltage	V _{DD}	-	+24	+28	V _{DC}	
RF Power at inputs	-	-	-	+70	dBmV	single tone
Operating mounting Base temperature	T _{MB}	-20	-	+100	°C	
Storage Temperature	T _{STG}	-40		+100	°C	

Table 3: Operating Ranges

	Symbol	Min	Typ	Max	Unit	Conditions
RF Frequency	-	40	-	1000	MHz	

Table 4: Electrical Characteristics
(Test condition: 40 to 1000 GHz, T_{MB} = 30°C, 75 Ω loading)

	Symbol	Min	Typ	Max	Unit	Conditions
Power Gain	G _P	24	25	26	dB	f = 1 GHz
Slope cable equivalent	SL	-	1.5	-	dB	47 MHz to 1 GHz
Gain Flatness	-	-	±0.5	-	dB	47 MHz to 1 GHz (peak to valley)
Input Return Loss	S ₁₁	-	-	-20 -17	dB	40 - 500 MHz 500 - 1000 MHz
Output Return Loss	S ₂₂	-	-	-18 -16	dB	40 - 500 MHz 500 - 1000 MHz
CTB	-	-	-70 -70	-65 -	dBc	See Note 1 See Note 2
CSO	-	-	-70 -70	-65 -	dBc	See Note 1 See Note 2
XMOD	-	-	-63	-	dBc	See Note 3
Noise Figure	-	-	7.5	8.5	dB	
Supply Current	-	-	430	445	mA	

Notes:

- (1) 79 analog NTSC channels to 550 MHz + 75 digital QAM channels (at -6 dB offset) with 15.5 dB tilt referenced to +55 dBmV output power at 1GHz.
- (2) 79 analog NTSC channels with flat output of +44 dBmV @ 550 MHz plus 53 digital channels to -6 dB offset to 1GHz.
- (3) +58 dBmV Output (referenced to 1 GHz); 79 NTSC Analog Channels; 14 dB tilt at 1 GHz; plus 75 digital channels with QAM at -6 dB offset above 550 MHz.

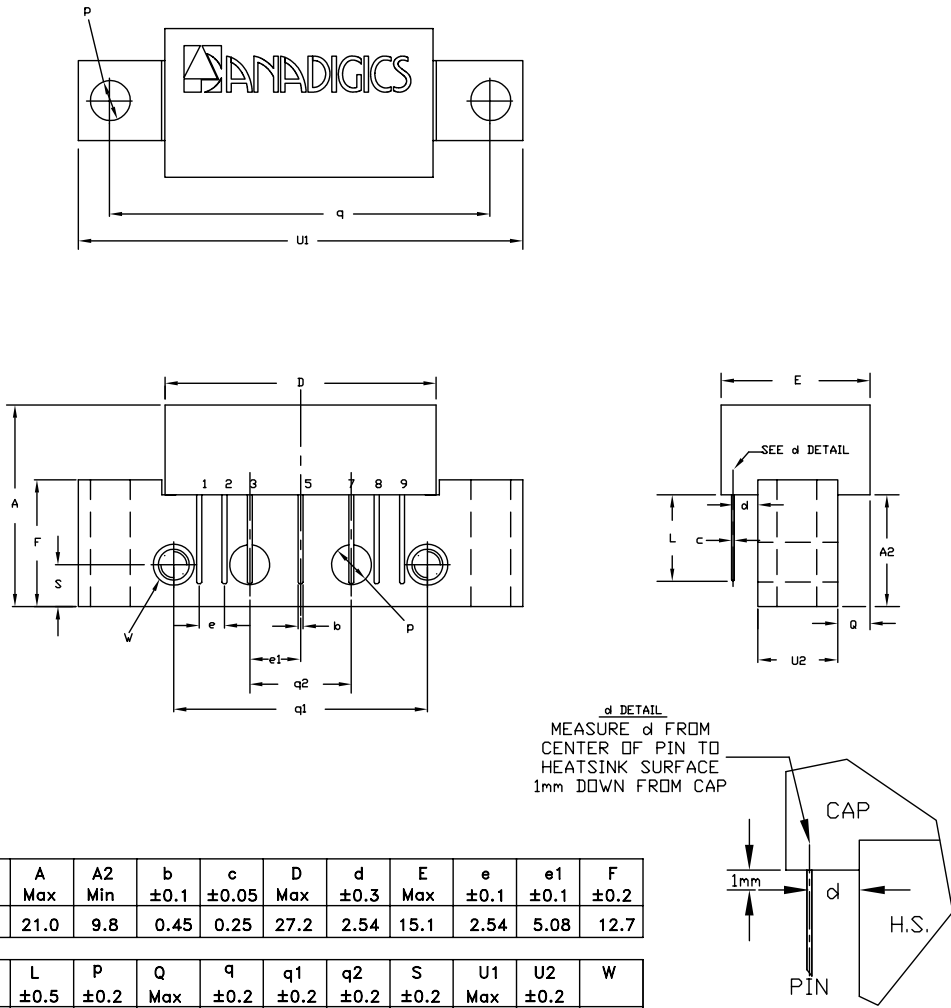

Figure 3: Hybrid Line Amp Physical Outline

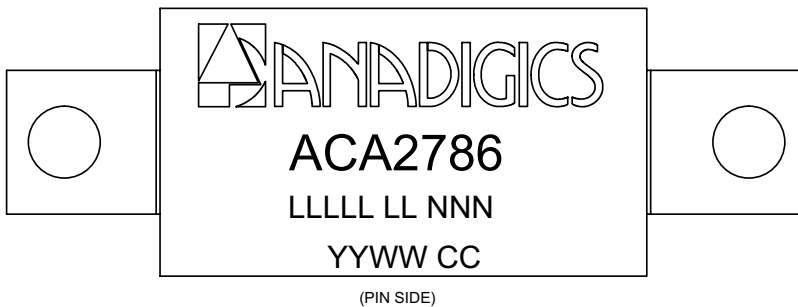

Figure 4: Branding Specification

ORDERING INFORMATION

ORDER NUMBER	TEMPERATURE RANGE	PACKAGE DESCRIPTION	COMPONENT PACKAGING
ACA2786V0	-20 °C to +100 °C	SOT-115J	100 Piece Box
ACA2786P9	-20 °C to +100 °C	SOT-115J	Special handling



ANADIGICS, Inc.
141 Mount Bethel Road
Warren, New Jersey 07059, U.S.A.
Tel: +1 (908) 668-5000
Fax: +1 (908) 668-5132

URL: <http://www.anadigics.com>

IMPORTANT NOTICE

ANADIGICS, Inc. reserves the right to make changes to its products or to discontinue any product at any time without notice. The product specifications contained in Advanced Product Information sheets and Preliminary Data Sheets are subject to change prior to a product's formal introduction. Information in Data Sheets have been carefully checked and are assumed to be reliable; however, ANADIGICS assumes no responsibilities for inaccuracies. ANADIGICS strongly urges customers to verify that the information they are using is current before placing orders.

WARNING

ANADIGICS products are not intended for use in life support appliances, devices or systems. Use of an ANADIGICS product in any such application without written consent is prohibited.