



PWR5XX Series

4W Rated Output Power UNREGULATED DC/DC CONVERTER SERIES

FEATURES

- Isolation Voltage Tested per UL544, VDE750, and CSAC22.2 Dielectric Withstand Requirement
- Barrier Leakage Current 100% Tested at 240VAC
- Quad Channel
- Single or Dual Unregulated Outputs
- Wide Operating Temperature Range:
-40°C to +100°C
- Input and Output Filtering
- Six-Sided Shielding

DESCRIPTION

The PWR5XX Series offers a large selection of unregulated four-watt DC-DC converters for use in

diverse applications as process control, telecommunications, portable equipment, medical systems, airborne and shipboard electronic circuits, and automatic test equipment.

Thirty-six models allow the user to select input voltages ranging from +5VDC to +48VDC and output voltages of +5, +12, +15, ±5, ±12, or ±15V. Surface-mounted devices and manufacturing processes are used in the PWR5XX Series to give the user a device which is more environmentally rugged than most DC-DC converters. The use of surface-mount technologies also gives the PWR5XX Series superior isolation voltage.

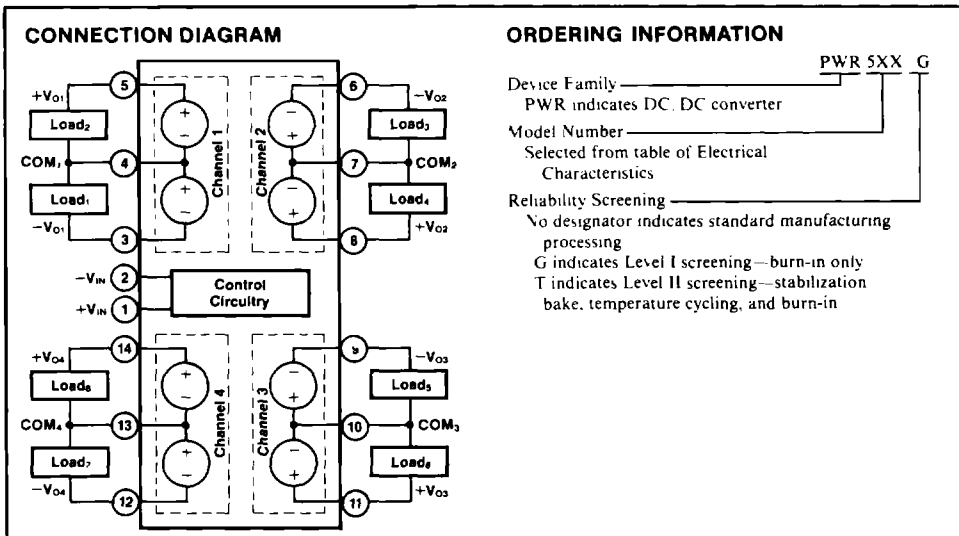

International Airport Industrial Park · P.O. Box 11400 · Tucson, Arizona 85734 · Tel. (602) 746-1111 · Twx: 910-952-1111 · Cable BBRCORP · Telex 66-6491

PDS-674B

SPECIFICATIONS

ELECTRICAL CHARACTERISTICS⁽¹⁾

Model	Nominal Input Voltage (VDC)	Rated ⁽²⁾ Output Voltage (VDC)	Rated ⁽²⁾ Output Current (mA)	Maximum Input Current (mA)
PWR500	5	5	200	1300
PWR501		12	84	1290
PWR502		15	67	1230
PWR503		±5	±100	1300
PWR504		±12	±42	1290
PWR505		±15	±34	1230
PWR506	12	5	200	490
PWR507		12	84	444
PWR508		15	67	444
PWR509		±5	±100	490
PWR510		±12	±42	444
PWR511		±15	±34	444
PWR512	15	5	200	390
PWR513		12	84	355
PWR514		15	67	355
PWR515		±5	±100	390
PWR516		±12	±42	355
PWR517		±15	±34	355
PWR518	24	5	200	245
PWR519		12	84	222
PWR520		15	67	222
PWR521		±5	±100	245
PWR522		±12	±42	222
PWR523		±15	±34	222
PWR524	28	5	200	210
PWR525		12	84	190
PWR526		15	67	190
PWR527		±5	±100	210
PWR528		±12	±42	190
PWR529		±15	±34	190
PWR530	48	5	200	123
PWR531		12	84	111
PWR532		15	67	111
PWR533		±5	±100	123
PWR534		±12	±42	111
PWR535		±15	±34	111

COMMON SPECIFICATIONS⁽¹⁾

Parameter	Conditions	Min	Typ	Max	Units
INPUT					
Voltage Range		±20% of Rated Input			
Input Ripple Current	I _{LOAD} = Rated Load		70		mA, p-p
ISOLATION					
Rated Voltage		750			VDC
Resistance			10		GΩ
Capacitance			55		pF
Leakage Current	V _{ISO} = 240VAC			15	μA
OUTPUT					
Voltage Accuracy	I _{LOAD} = Rated Load			±5	%
Voltage (No Load)	V _{OUT} = 5 Models			7	VDC
	V _{OUT} = 12 Models			15	VDC
	V _{OUT} = 15 Models			18	VDC
Ripple Voltage	I _{LOAD} = Rated Load		1		% of V _{OUT} , p-p
Line Regulation			1		%/%
TEMPERATURE					
Specification		-25		+85	°C
Operation		-40		+100	°C
Storage		-55		+125	°C

NOTE (1) Specifications typical at T_A = +25°C, nominal input voltage, and rated output current unless otherwise noted (2) Specifications apply to each output

ABSOLUTE MAXIMUM RATINGS

Input Voltage	120% × Rated voltage
Output Short-Circuit Duration	Momentary
Internal Power Dissipation	2.5W
Junction Temperature	+150°C
Package Thermal Resistance	38°C/W
Lead Temperature (soldering, 10 seconds)	+300°C

MECHANICAL

(Top View)

(Bottom View)

(Side View)

Notes:
 All dimensions are in inches (millimeters)
 GRID: 0.100 inches (2.54 millimeters)
 MATERIAL: Low thermal resistance molding compound which has excellent chemical resistance, wide operating temperature range and good electrical properties under high humidity environments. Lead material is brass with a hot-solder-dipped surface to allow ease of solderability.