

To our customers,

Old Company Name in Catalogs and Other Documents

On April 1st, 2010, NEC Electronics Corporation merged with Renesas Technology Corporation, and Renesas Electronics Corporation took over all the business of both companies. Therefore, although the old company name remains in this document, it is a valid Renesas Electronics document. We appreciate your understanding.

Renesas Electronics website: <http://www.renesas.com>

April 1st, 2010
Renesas Electronics Corporation

Issued by: Renesas Electronics Corporation (<http://www.renesas.com>)

Send any inquiries to <http://www.renesas.com/inquiry>.

Notice

1. All information included in this document is current as of the date this document is issued. Such information, however, is subject to change without any prior notice. Before purchasing or using any Renesas Electronics products listed herein, please confirm the latest product information with a Renesas Electronics sales office. Also, please pay regular and careful attention to additional and different information to be disclosed by Renesas Electronics such as that disclosed through our website.
2. Renesas Electronics does not assume any liability for infringement of patents, copyrights, or other intellectual property rights of third parties by or arising from the use of Renesas Electronics products or technical information described in this document. No license, express, implied or otherwise, is granted hereby under any patents, copyrights or other intellectual property rights of Renesas Electronics or others.
3. You should not alter, modify, copy, or otherwise misappropriate any Renesas Electronics product, whether in whole or in part.
4. Descriptions of circuits, software and other related information in this document are provided only to illustrate the operation of semiconductor products and application examples. You are fully responsible for the incorporation of these circuits, software, and information in the design of your equipment. Renesas Electronics assumes no responsibility for any losses incurred by you or third parties arising from the use of these circuits, software, or information.
5. When exporting the products or technology described in this document, you should comply with the applicable export control laws and regulations and follow the procedures required by such laws and regulations. You should not use Renesas Electronics products or the technology described in this document for any purpose relating to military applications or use by the military, including but not limited to the development of weapons of mass destruction. Renesas Electronics products and technology may not be used for or incorporated into any products or systems whose manufacture, use, or sale is prohibited under any applicable domestic or foreign laws or regulations.
6. Renesas Electronics has used reasonable care in preparing the information included in this document, but Renesas Electronics does not warrant that such information is error free. Renesas Electronics assumes no liability whatsoever for any damages incurred by you resulting from errors in or omissions from the information included herein.
7. Renesas Electronics products are classified according to the following three quality grades: “Standard”, “High Quality”, and “Specific”. The recommended applications for each Renesas Electronics product depends on the product’s quality grade, as indicated below. You must check the quality grade of each Renesas Electronics product before using it in a particular application. You may not use any Renesas Electronics product for any application categorized as “Specific” without the prior written consent of Renesas Electronics. Further, you may not use any Renesas Electronics product for any application for which it is not intended without the prior written consent of Renesas Electronics. Renesas Electronics shall not be in any way liable for any damages or losses incurred by you or third parties arising from the use of any Renesas Electronics product for an application categorized as “Specific” or for which the product is not intended where you have failed to obtain the prior written consent of Renesas Electronics. The quality grade of each Renesas Electronics product is “Standard” unless otherwise expressly specified in a Renesas Electronics data sheets or data books, etc.
 - “Standard”: Computers; office equipment; communications equipment; test and measurement equipment; audio and visual equipment; home electronic appliances; machine tools; personal electronic equipment; and industrial robots.
 - “High Quality”: Transportation equipment (automobiles, trains, ships, etc.); traffic control systems; anti-disaster systems; anti-crime systems; safety equipment; and medical equipment not specifically designed for life support.
 - “Specific”: Aircraft; aerospace equipment; submersible repeaters; nuclear reactor control systems; medical equipment or systems for life support (e.g. artificial life support devices or systems), surgical implantations, or healthcare intervention (e.g. excision, etc.), and any other applications or purposes that pose a direct threat to human life.
8. You should use the Renesas Electronics products described in this document within the range specified by Renesas Electronics, especially with respect to the maximum rating, operating supply voltage range, movement power voltage range, heat radiation characteristics, installation and other product characteristics. Renesas Electronics shall have no liability for malfunctions or damages arising out of the use of Renesas Electronics products beyond such specified ranges.
9. Although Renesas Electronics endeavors to improve the quality and reliability of its products, semiconductor products have specific characteristics such as the occurrence of failure at a certain rate and malfunctions under certain use conditions. Further, Renesas Electronics products are not subject to radiation resistance design. Please be sure to implement safety measures to guard them against the possibility of physical injury, and injury or damage caused by fire in the event of the failure of a Renesas Electronics product, such as safety design for hardware and software including but not limited to redundancy, fire control and malfunction prevention, appropriate treatment for aging degradation or any other appropriate measures. Because the evaluation of microcomputer software alone is very difficult, please evaluate the safety of the final products or system manufactured by you.
10. Please contact a Renesas Electronics sales office for details as to environmental matters such as the environmental compatibility of each Renesas Electronics product. Please use Renesas Electronics products in compliance with all applicable laws and regulations that regulate the inclusion or use of controlled substances, including without limitation, the EU RoHS Directive. Renesas Electronics assumes no liability for damages or losses occurring as a result of your noncompliance with applicable laws and regulations.
11. This document may not be reproduced or duplicated, in any form, in whole or in part, without prior written consent of Renesas Electronics.
12. Please contact a Renesas Electronics sales office if you have any questions regarding the information contained in this document or Renesas Electronics products, or if you have any other inquiries.

(Note 1) “Renesas Electronics” as used in this document means Renesas Electronics Corporation and also includes its majority-owned subsidiaries.

(Note 2) “Renesas Electronics product(s)” means any product developed or manufactured by or for Renesas Electronics.

2-CHANNEL 16-BIT D/A CONVERTER FOR AUDIO APPLICATION

The μ PD6379 and 6379A are 2-channel 16-bit D/A converters for digital audio signal demodulation. These D/A converters employ the resistor string conversion method which has been tested by existing model μ PD6376 but they are more compact and require fewer external components than the μ PD6376. In addition, low-voltage models, the μ PD6379L and 6379AL (minimum operating supply voltage = +3.0 V) are also available for applications in portable systems.

FEATURES

- Resistor string conversion method
- 0-point digital shift circuit
- $\times 4$ oversampling
Sampling frequency: 200 kHz MAX.
- Signal processing format for 2's complement, MSB first, and backward justification data accommodated
- Left and right in-phase output
- High performance (at $V_{DD} = +5.0$ V)
S/N ratio: 100 dB TYP.
Dynamic range: 96 dB TYP.
- Low-voltage models available
- Bipolar LR clock (LRCK)
- Low power dissipation: 10 mW TYP.
(with μ PD6379L, 6379AL at $V_{DD} = +3.3$ V)

	LRCK	LRCK = L when L-ch data is input	LRCK = H when L-ch data is input
+3.3 V ($V_{DD} = +3.0$ to 5.5 V)		μ PD6379L	μ PD6379AL
+5.0 V ($V_{DD} = +4.5$ to 5.5 V)		μ PD6379	μ PD6379A

- Few external components
Internal output operational amplifier
Only one electrolytic capacitor required for smoothing reference voltage, instead of two capacitors required by existing D/A converters
- Small package: 8-pin plastic SOP (5.72 mm (225))

The information in this document is subject to change without notice. Before using this document, please confirm that this is the latest version.
Not all devices/types available in every country. Please check with local NEC representative for availability and additional information.

ORDERING INFORMATION

Part number	Package
μ PD6379GR	8-pin plastic SOP (5.72 mm (225))
μ PD6379LGR	8-pin plastic SOP (5.72 mm (225))
μ PD6379AGR	8-pin plastic SOP (5.72 mm (225))
μ PD6379ALGR	8-pin plastic SOP (5.72 mm (225))

BLOCK DIAGRAM

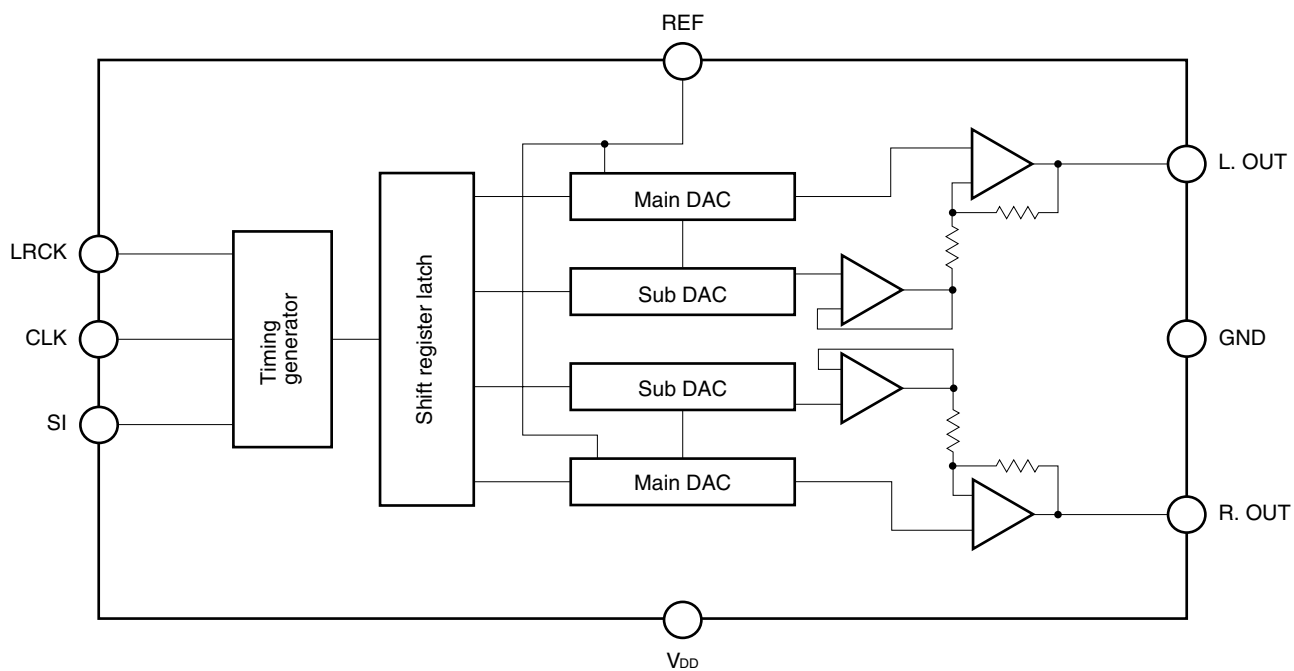

PIN CONFIGURATIONS (Top View)

8-pin plastic SOP (5.72 mm (225))

- μ PD6379GR, 6379LGR

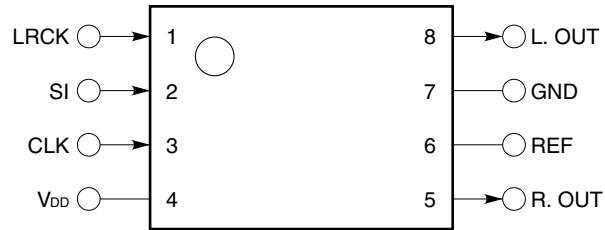

- μ PD6379AGR, 6379ALGR

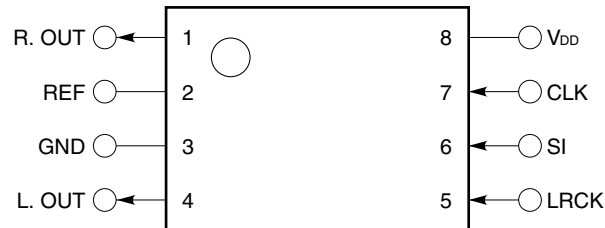

Remark The pin configuration of the μ PD6379 and 6379L is different from that of the μ PD6379A and 6379AL.

1. PIN FUNCTIONS

Table 1-1 Pin Functions

Pin No.		Name	Symbol	I/O	Function
μPD6379, 6379L	μPD6379A, 6379AL				
1	5	Left/Right Clock	LRCK	Input	Input pin to identify left or right input data. μPD6379, 6379L: Input "L" to this pin when inputting L-ch data to SI pin. μPD6379A, 6379AL: Input "H" to this pin when inputting L-ch data to SI pin.
2	6	Serial Input	SI	Input	Serial data input pin. Input data on 2's complement, MSB first, and backward justification.
3	7	Clock	CLK	Input	Serial input data read clock (bit clock) input pin
4	8	Supply Voltage	V _{DD}	–	Positive power supply pin
5	1	R-ch Output	R. OUT	Output	Right analog signal output pin
6	2	Reference Voltage	REF	–	Reference voltage pin. Connect this pin to GND through capacitor.
7	3	Ground	GND	–	GND pin
8	4	L-ch Output	L. OUT	Output	Left analog signal output pin

2. ELECTRICAL SPECIFICATIONS

ABSOLUTE MAXIMUM RATINGS ($T_A = 25\text{ }^\circ\text{C}$)

Parameter	Symbol	Ratings	Unit
Supply voltage	V_{DD}	-0.3 to +7.0	V
Input voltage	V_i	-0.3 to $V_{DD} + 0.3$	V
Output voltage	V_o	-0.3 to $V_{DD} + 0.3$	V
Permissible package power dissipation	P_D	220 ($T_A = 75\text{ }^\circ\text{C}$)	mW
Operating ambient temperature	T_A	-20 to +75	$^\circ\text{C}$
Storage temperature	T_{stg}	-40 to +125	$^\circ\text{C}$

Caution Exposure to Absolute Maximum Ratings for extended periods may affect device reliability; exceeding the ratings could cause permanent damage. The parameters apply independently. The device should be operated within the limits specified under DC and AC Characteristics.

μPD6379, 6379A

RECOMMENDED OPERATING CONDITIONS

Parameter	Symbol	Condition	MIN.	TYP.	MAX.	Unit
Supply voltage	V _{DD}		4.5	5.0	5.5	V
Logic input voltage (HIGH)	V _{IH}		0.7 V _{DD}		V _{DD}	V
Logic input voltage (LOW)	V _{IL}		0		0.3 V _{DD}	V
Operating ambient temperature	T _A		-20	+25	+75	°C
Output load resistance	R _L	R. OUT, L. OUT pins	5			kΩ
Conversion frequency	f _s				200	kHz
Clock frequency	f _{CLK}				10	MHz
Clock pulse width	t _{SCK}		40			ns
SI, LRCK setup time	t _{DC}		12			ns
SI, LRCK hold time	t _{CD}		12			ns

ELECTRICAL CHARACTERISTICS (T_A = 25 °C, V_{DD} = +5 V, f_s = 176.4 kHz)

Parameter	Symbol	Condition	MIN.	TYP.	MAX.	Unit
Resolution	RES			16		Bit
Total harmonic distortion	THD	f _{IN} = 1 kHz, 0 dB		0.04	0.09	%
★ Full-scale output voltage	V _{FS}		1.7	2.0	2.3	V _{P-P}
S/N ratio	S/N	With A-weight filter	93	100		dB
Dynamic range	D.R	f _{IN} = 1 kHz, -60 dB	89	96		dB
Crosstalk	C.T	One side channel = 0 dB, f _{IN} = 1 kHz	82	96		dB
Current dissipation	I _{DD}	f _{IN} = 1 kHz, 0 dB		5	12	mA

μPD6379L, 6379AL

RECOMMENDED OPERATING CONDITIONS

Parameter	Symbol	Condition	MIN.	TYP.	MAX.	Unit
Supply voltage	V _{DD}		3.0	3.3	5.5	V
Logic input voltage (HIGH)	V _{IH}		0.7 V _{DD}		V _{DD}	V
Logic input voltage (LOW)	V _{IL}		0		0.3 V _{DD}	V
Operating ambient temperature	T _A		-20	+25	+75	°C
Output load resistance	R _L	R. OUT, L. OUT pins	10			kΩ
Conversion frequency	f _s				200	kHz
Clock frequency	f _{CLK}				10	MHz
Clock pulse width	t _{SCK}		40			ns
SI, LRCK setup time	t _{DC}		12			ns
SI, LRCK hold time	t _{CD}		12			ns

ELECTRICAL CHARACTERISTICS (T_A = 25 °C, V_{DD} = +3.3 V, f_s = 176.4 kHz)

Parameter	Symbol	Condition	MIN.	TYP.	MAX.	Unit
Resolution	RES			16		Bit
Total harmonic distortion	THD	f _{IN} = 1 kHz, 0 dB		0.04	0.09	%
Full-scale output voltage	V _{FS}		1.12	1.32	1.52	V _{p-p}
S/N ratio	S/N	With A-weight filter	93	98		dB
Dynamic range	D.R	f _{IN} = 1 kHz, -60 dB	89	93		dB
Crosstalk	C.T	One side channel = 0 dB, f _{IN} = 1 kHz	82	93		dB
Current dissipation	I _{DD}	f _{IN} = 1 kHz, 0 dB		3	6	mA

★

Timing Chart

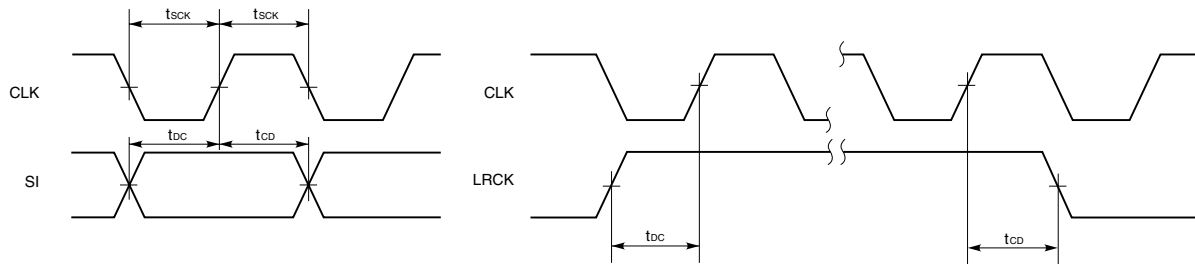
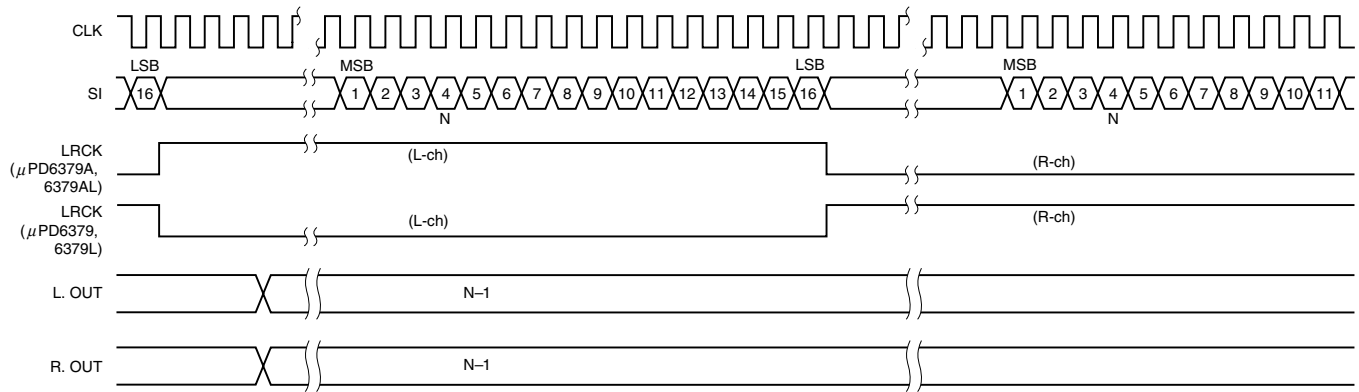

3. APPLICATION CIRCUIT EXAMPLE

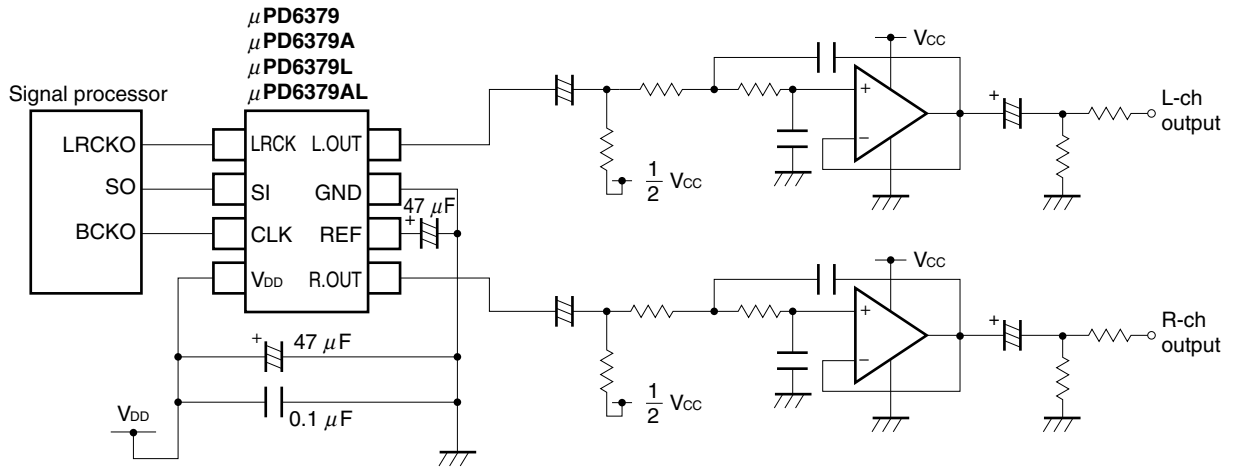

4. NOTES ON USE

(1) Input signal format

- Input data must be input as 2's complement, MSB first, and backward justification.
- 2's complement is a method of expressing both positive numbers and negative numbers as binary numbers. See the table below.

2's Complement				Decimal Number	L.OUT, R.OUT Pin Voltage TYP. (V) (Reference Values) ^{Note 1}	
(MSB)			(LSB)		V _{DD} = 5.0 V	V _{DD} = 3.3 V ^{Note 2}
0111	1111	1111	1111	+32767	3.0	1.98
0111	1111	1111	1110	+32766	⋮	⋮
		⋮		⋮	⋮	⋮
0000	0000	0000	0001	+1	⋮	⋮
0000	0000	0000	0000	0	2.0	1.32
1111	1111	1111	1111	-1	⋮	⋮
		⋮		⋮	⋮	⋮
1000	0000	0000	0001	-32767	⋮	⋮
1000	0000	0000	0000	-32768	1.0	0.66

- Notes**
1. Values differ depending on IC fabrication variations, supply voltage fluctuations, and ambient temperature.
 2. μPD6379L, 6379AL

- Make sure that the delimiter of each bit of the data (SI) and the changing timing of LRCK coincide with the falling edge of CLK.
- It is necessary that 16 clocks be input during 1 sample data period (16 bits). Make sure that the time width of 1 bit coincides with one cycle of the clock.
- In the input data, the 16 bits preceding the change point of LRCK (shown in "1 sample data period" in Fig. 4-1, and Fig. 4-2) are considered to be valid data and are incorporated for use in D/A conversion.

- If the clock is also supplied to CLK while data is not sampled (refer to Fig. 4-1), make sure that the changing timing of LRCK coincides with the falling edge (point A) of CLK after the LSB has been input.

Fig. 4-1 Input Timing Chart (1)

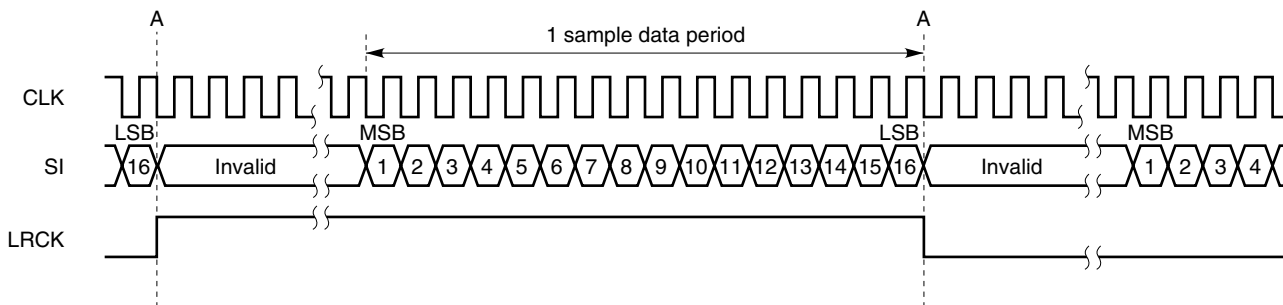

- If the clock is supplied to CLK only while data is sampled (refer to Fig. 4-2), set the changing timing of LRCK in between the falling edge (point A) of CLK after the LSB has been input and the start of inputting the next MSB (point B) (points A and B are included).

Fig. 4-2 Input Timing Chart (2)

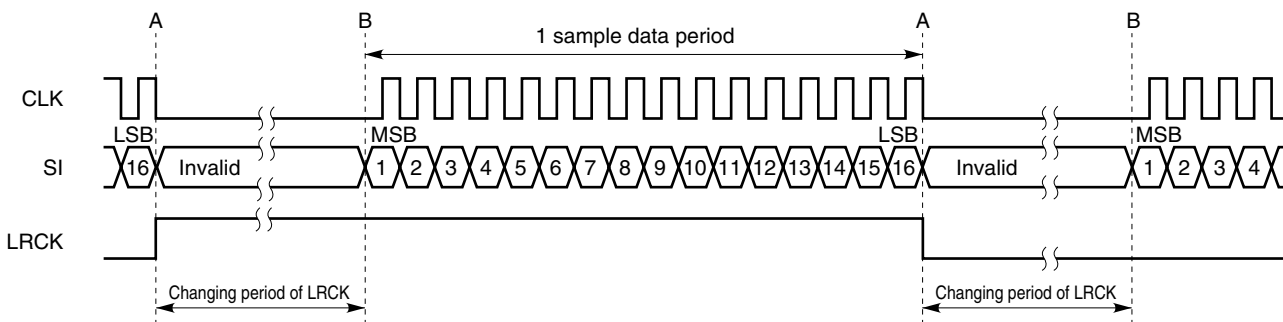

(2) Output signal updating timing

The L.OUT and R.OUT signals are updated after the input of 3.5 clocks following the change point indicating the end of the LRCK pin R-ch data input period. Therefore, when the clock is supplied to CLK only during D/A conversion, the clock must be stopped after the L.OUT and R.OUT signals corresponding to the last input data are output. Be aware that the L.OUT and R.OUT signals corresponding to the last sample data are not output, especially when the clock is supplied to CLK only during a sample data period.

Fig. 4-3 Output Timing Chart (1) (for continuous clocks)

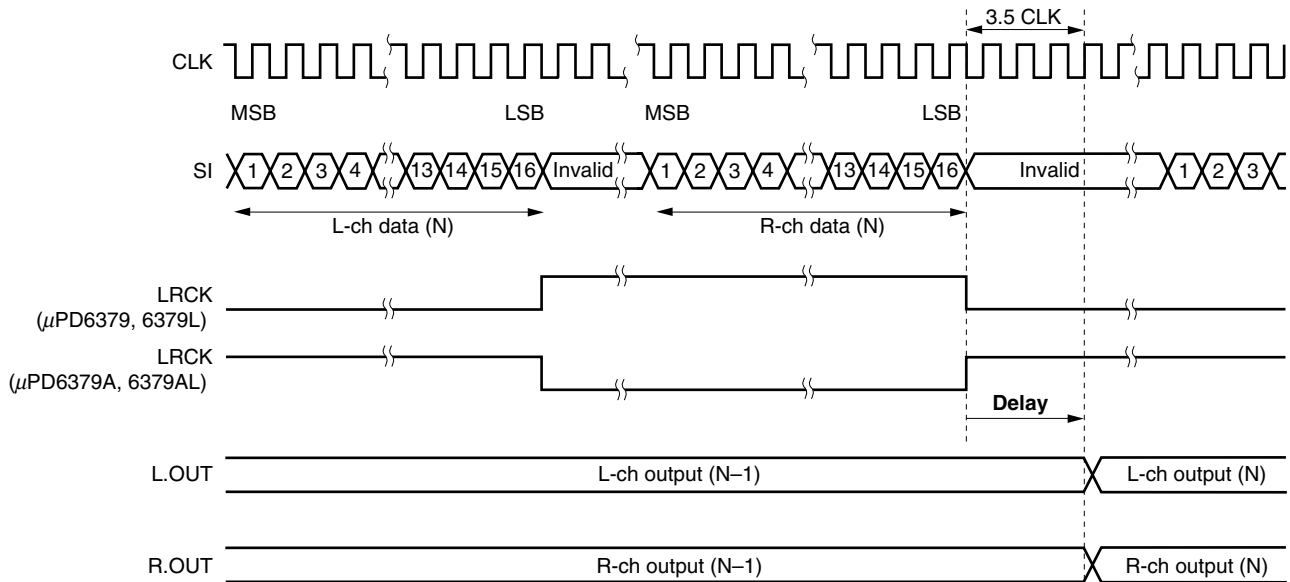
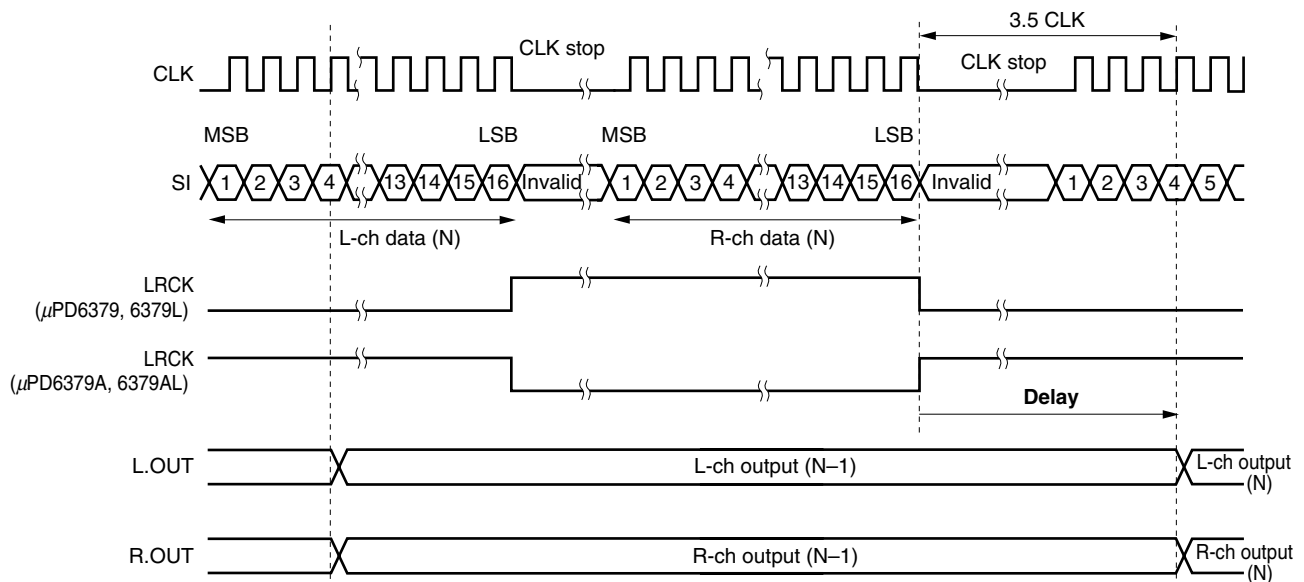

Fig. 4-4 Output Timing Chart (2) (when there is an interval which the clock is stopped)



(3) Countermeasures against shock noise

It is recommended that a mute circuit be connected to the next stage of the D/A converter. If a mute circuit is not provided, shock noise may occur when power is applied.

5. PACKAGE DRAWING

8-PIN PLASTIC SOP (5.72 mm (225))

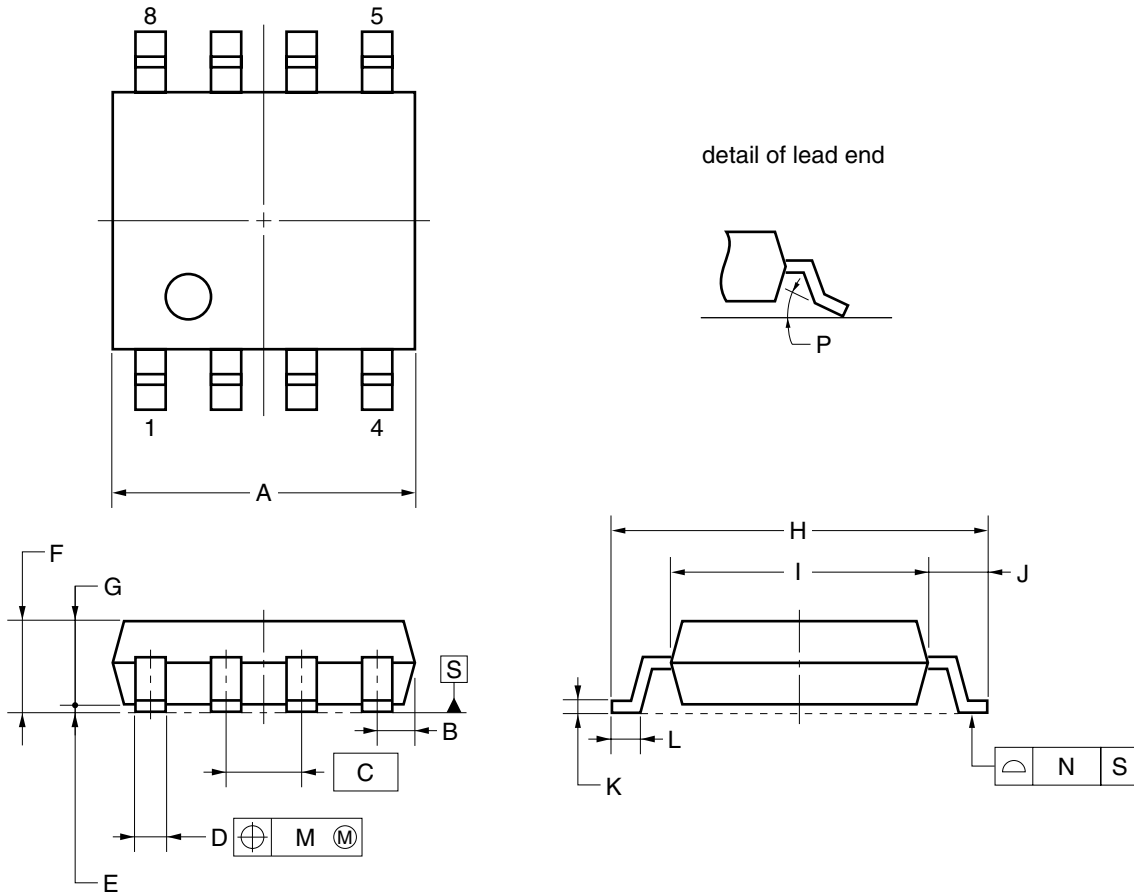

NOTE

Each lead centerline is located within 0.12 mm of its true position (T.P.) at maximum material condition.

ITEM	MILLIMETERS
A	5.2 ^{+0.17} / _{-0.20}
B	0.78 MAX.
C	1.27 (T.P.)
D	0.42 ^{+0.08} / _{-0.07}
E	0.1±0.1
F	1.59±0.21
G	1.49
H	6.5±0.3
I	4.4±0.15
J	1.1±0.2
K	0.17 ^{+0.08} / _{-0.07}
L	0.6±0.2
M	0.12
N	0.10
P	3° ^{+7°} / _{-3°}

S8GM-50-225B-6

6. RECOMMENDED SOLDERING CONDITIONS

The following conditions must be met for soldering conditions of the product.

For more details, refer to our document “**SEMICONDUCTOR DEVICE MOUNTING TECHNOLOGY MANUAL**” (C10535E).

Please consult with our sales offices in case other soldering process is used, or in case the soldering is done under different conditions.

Table 6-1 Soldering Conditions

μPD6379GR, 6379AGR, 6379LGR, 6379ALGR : 8-pin plastic SOP (5.72 mm (225))

Soldering Process	Soldering Conditions	Symbol
Infrared ray reflow	Peak temperature of package surface: 235 °C or below, Reflow time: 30 seconds or less (at 210 °C or higher), Number of reflow processes: MAX. 2.	IR35-00-2
VPS	Peak temperature of package surface: 215 °C or below, Reflow time: 40 seconds or less (at 200 °C or higher), Number of reflow processes: MAX. 2.	VP15-00-2
Wave soldering	Solder temperature: 260 °C or below, Flow time: 10 seconds or less, Pre-heating temperature: 120 °C or below (Package surface), Number of flow processes: MAX. 1.	WS60-00-1
Partial heating method	Terminal temperature: 300 °C or below, Time: 3 seconds or less (Per one side of the device).	—

Caution Do not apply more than one soldering method at any one time, except for “Partial heating method”.

NOTES FOR CMOS DEVICES

① PRECAUTION AGAINST ESD FOR SEMICONDUCTORS

Note:

Strong electric field, when exposed to a MOS device, can cause destruction of the gate oxide and ultimately degrade the device operation. Steps must be taken to stop generation of static electricity as much as possible, and quickly dissipate it once, when it has occurred. Environmental control must be adequate. When it is dry, humidifier should be used. It is recommended to avoid using insulators that easily build static electricity. Semiconductor devices must be stored and transported in an anti-static container, static shielding bag or conductive material. All test and measurement tools including work bench and floor should be grounded. The operator should be grounded using wrist strap. Semiconductor devices must not be touched with bare hands. Similar precautions need to be taken for PW boards with semiconductor devices on it.

② HANDLING OF UNUSED INPUT PINS FOR CMOS

Note:

No connection for CMOS device inputs can be cause of malfunction. If no connection is provided to the input pins, it is possible that an internal input level may be generated due to noise, etc., hence causing malfunction. CMOS devices behave differently than Bipolar or NMOS devices. Input levels of CMOS devices must be fixed high or low by using a pull-up or pull-down circuitry. Each unused pin should be connected to V_{DD} or GND with a resistor, if it is considered to have a possibility of being an output pin. All handling related to the unused pins must be judged device by device and related specifications governing the devices.

③ STATUS BEFORE INITIALIZATION OF MOS DEVICES

Note:

Power-on does not necessarily define initial status of MOS device. Production process of MOS does not define the initial operation status of the device. Immediately after the power source is turned ON, the devices with reset function have not yet been initialized. Hence, power-on does not guarantee out-pin levels, I/O settings or contents of registers. Device is not initialized until the reset signal is received. Reset operation must be executed immediately after power-on for devices having reset function.

- **The information in this document is current as of May, 2002. The information is subject to change without notice. For actual design-in, refer to the latest publications of NEC's data sheets or data books, etc., for the most up-to-date specifications of NEC semiconductor products. Not all products and/or types are available in every country. Please check with an NEC sales representative for availability and additional information.**
- No part of this document may be copied or reproduced in any form or by any means without prior written consent of NEC. NEC assumes no responsibility for any errors that may appear in this document.
- NEC does not assume any liability for infringement of patents, copyrights or other intellectual property rights of third parties by or arising from the use of NEC semiconductor products listed in this document or any other liability arising from the use of such products. No license, express, implied or otherwise, is granted under any patents, copyrights or other intellectual property rights of NEC or others.
- Descriptions of circuits, software and other related information in this document are provided for illustrative purposes in semiconductor product operation and application examples. The incorporation of these circuits, software and information in the design of customer's equipment shall be done under the full responsibility of customer. NEC assumes no responsibility for any losses incurred by customers or third parties arising from the use of these circuits, software and information.
- While NEC endeavours to enhance the quality, reliability and safety of NEC semiconductor products, customers agree and acknowledge that the possibility of defects thereof cannot be eliminated entirely. To minimize risks of damage to property or injury (including death) to persons arising from defects in NEC semiconductor products, customers must incorporate sufficient safety measures in their design, such as redundancy, fire-containment, and anti-failure features.
- NEC semiconductor products are classified into the following three quality grades:
"Standard", "Special" and "Specific". The "Specific" quality grade applies only to semiconductor products developed based on a customer-designated "quality assurance program" for a specific application. The recommended applications of a semiconductor product depend on its quality grade, as indicated below. Customers must check the quality grade of each semiconductor product before using it in a particular application.
 - "Standard": Computers, office equipment, communications equipment, test and measurement equipment, audio and visual equipment, home electronic appliances, machine tools, personal electronic equipment and industrial robots
 - "Special": Transportation equipment (automobiles, trains, ships, etc.), traffic control systems, anti-disaster systems, anti-crime systems, safety equipment and medical equipment (not specifically designed for life support)
 - "Specific": Aircraft, aerospace equipment, submersible repeaters, nuclear reactor control systems, life support systems and medical equipment for life support, etc.

The quality grade of NEC semiconductor products is "Standard" unless otherwise expressly specified in NEC's data sheets or data books, etc. If customers wish to use NEC semiconductor products in applications not intended by NEC, they must contact an NEC sales representative in advance to determine NEC's willingness to support a given application.

(Note)

- (1) "NEC" as used in this statement means NEC Corporation and also includes its majority-owned subsidiaries.
- (2) "NEC semiconductor products" means any semiconductor product developed or manufactured by or for NEC (as defined above).