

Fig. 1

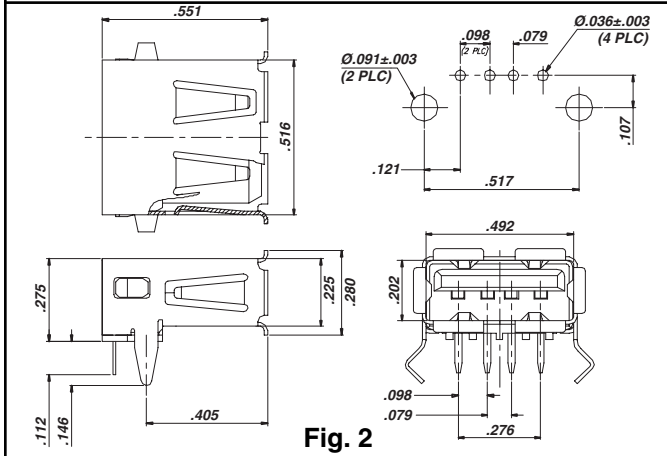

Fig. 2

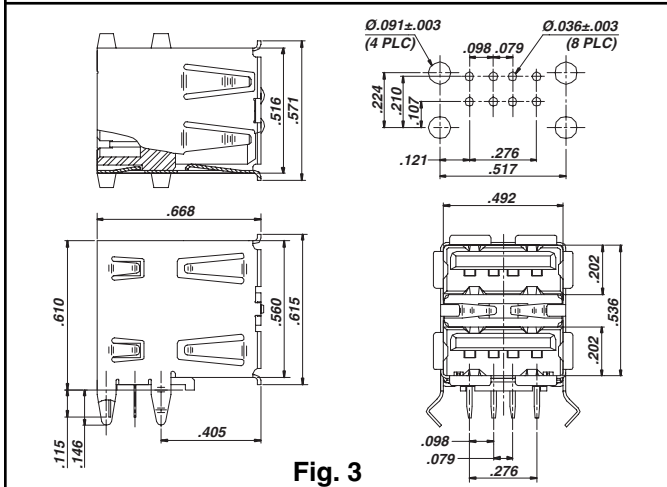

Fig. 3

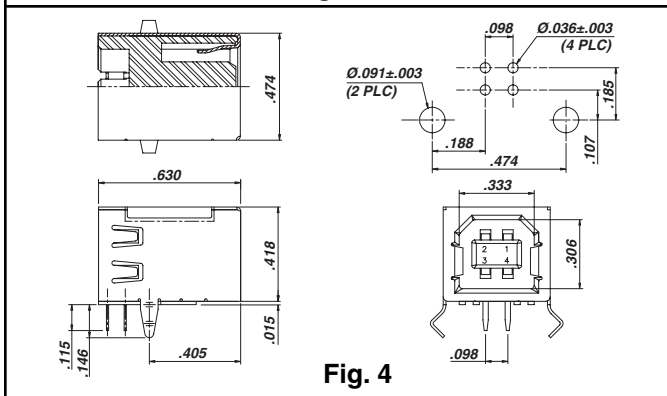
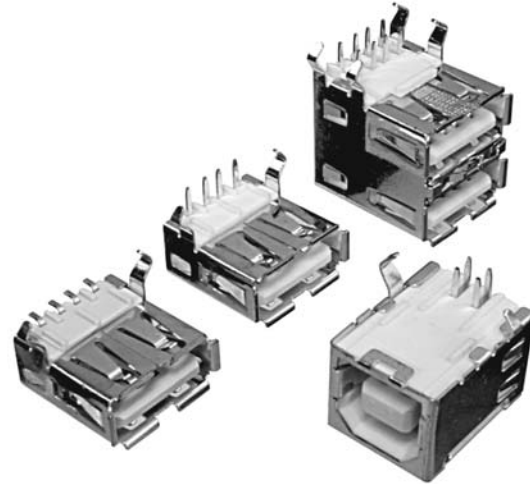

Fig. 4



Features

- USB receptacles for thru-hole & surface mount.
- Plug retention tabs.
- Kinked locating legs for secure PCB retention.
- Fully compatible with USB 1.0 specification.
- Passes 16MHz Signal Attenuation per ASTM-D-4566.
- Packaged in trays, 150 pieces per tray.

Ordering Information

Figure 1: Type A Receptacle, Single, Surface Mount
896-30-004-00-000

Figure 2: Type A Receptacle, Single, Thru Hole
896-30-004-90-000

Figure 3: Type A Receptacle, Double, Thru Hole
896-30-008-90-000

Figure 4: Type B Receptacle, Single, Thru Hole
897-30-004-90-000

Specifications

Materials:

Shell & contact material: copper alloy
Shell finish: tin/lead over copper
Contact finish: 30 μ m selective gold, tin/lead tail
Housing material: glass filled thermoplastic rated UL94V-0

Ratings:

Voltage: 30VAC (rms)
Current: 1A max. per contact for 30°C temperature rise
Thru-hole housings rated at 130°C for wave soldering
SMT housing rated at 240°C for reflow soldering

Electrical:

Contact resistance: 30m Ω max.
Insulation resistance: 1000M Ω min.
Dielectric withstanding voltage: 750VAC at sea level
Capacitance: 2pF max.

Mechanical:

Random vibration: No discontinuity >1 μ s per EIA 364-28, cond. V, letter A
Physical shock: No discontinuity >1 μ s per EIA 364-27, condition H
Durability: 1500 cycles min. per EIA 364-09
Mating force: 35 Newtons max. per EIA 364-13
Unmating force: 10 Newtons min. per EIA 364-13

Environmental:

Thermal shock per EIA 364-32, condition I
Humidity per EIA 364-31, method II, condition A
Temperature life per EIA 364-17, condition 3, method A

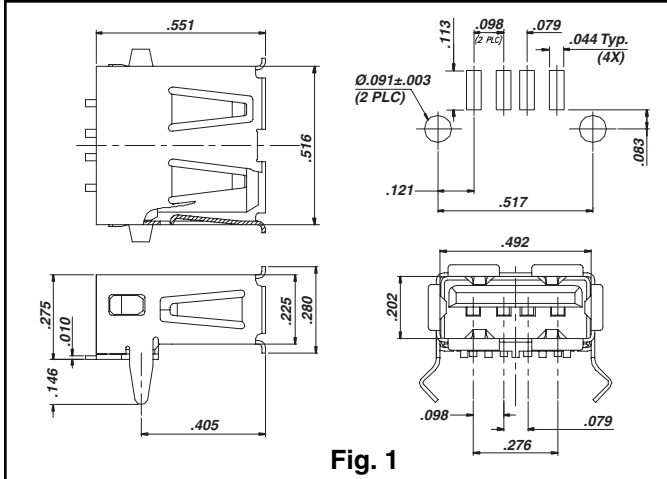

Fig. 1

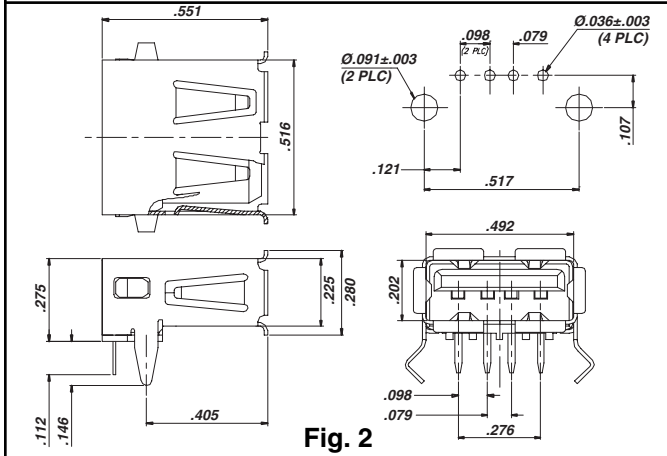

Fig. 2

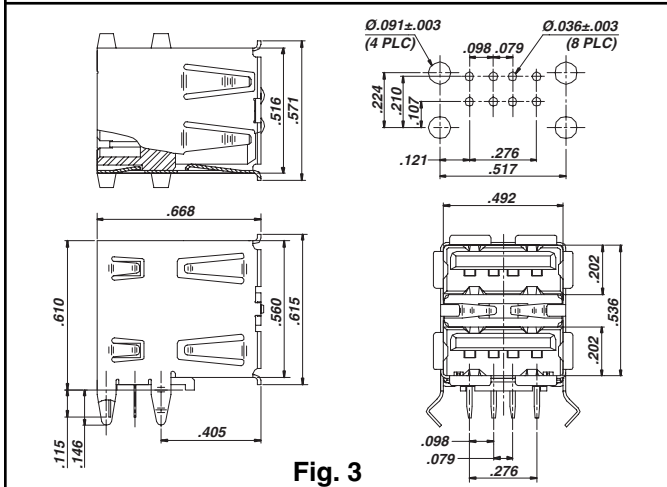

Fig. 3

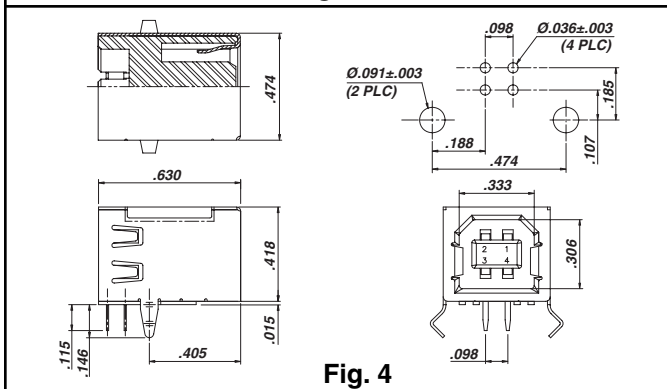
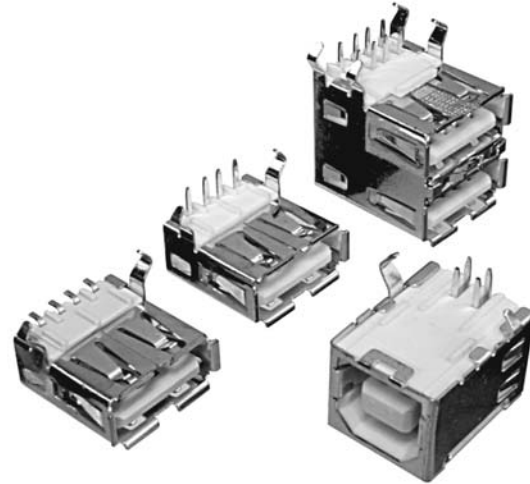

Fig. 4



Features

- USB receptacles for thru-hole & surface mount.
- Plug retention tabs.
- Kinked locating legs for secure PCB retention.
- Fully compatible with USB 1.0 & 2.0 specifications.
- Passes 16MHz Signal Attenuation per ASTM-D-4566.
- Packaged in trays, 150 pieces per tray.

Ordering Information

Figure 1: Type A Receptacle, Single, Surface Mount
896-43-004-00-000

Figure 2: Type A Receptacle, Single, Thru Hole
896-43-004-90-000

Figure 3: Type A Receptacle, Double, Thru Hole
896-43-008-90-000

Figure 4: Type B Receptacle, Single, Thru Hole
897-43-004-90-000

Specifications

Materials:

Shell & contact material: copper alloy
Shell finish: tin over copper
Contact finish: 30μ" selective gold, tin/copper tail
Housing material: high temp. thermoplastic rated UL94V-0

Ratings:

Voltage: 30VAC (rms)
Current: 1A max. per contact for 30°C temperature rise
All housing materials rated for "lead-free" soldering up to 260°C

Electrical:

Contact resistance: 30mΩ max.
Insulation resistance: 1000MΩ min.
Dielectric withstanding voltage: 750VAC at sea level
Capacitance: 2pF max.

Mechanical:

Random vibration: No discontinuity >1μs per EIA 364-28, cond. V, letter A
Physical shock: No discontinuity >1μs per EIA 364-27, condition H
Durability: 1500 cycles min. per EIA 364-09
Mating force: 35 Newtons max. per EIA 364-13
Unmating force: 10 Newtons min. per EIA 364-13

Environmental:

Thermal shock per EIA 364-32, condition I
Humidity per EIA 364-31, method II, condition A
Temperature life per EIA 364-17, condition 3, method A