

SLC-P1 Series
LC CONNECTOR PLUG
(for \varnothing 0.9 mm)

TECHNICAL SPECIFICATIONS

Seiko Instruments Inc.
OFC Division
8, Nakase 1-Chome, Mihama-ku
Chiba-shi, Chiba 261-8507, JAPAN
Telephone: +81-43-211-1211
Facsimile: +81-43-211-8039

SLC-P1 Series LC CONNECTOR PLUG (for \varnothing 0.9 mm)
TECHNICAL SPECIFICATIONS

Document Number [ACD-25B2-02](#)

ACD-25B2-01 June 2002
[ACD-25B2-02](#) [March 2003](#)

Copyright 2002, 2003 by **Seiko Instruments Inc.**
All right reserved.

The information contained herein shall not be reproduced or disclosed to any third party without the express written consent of **SII**.
The Specifications contained herein are subject to change without notice.

SII is a trademark of Seiko Instruments Inc.

Please address any questions, comments, and suggestions to:

Seiko Instruments USA Inc.
Electronics Components Division
2990 West Lomita Boulevard
Torrance, CA 90505, U.S.A.
Phone: +1-310-517-7780
Facsimile: +1-310-517-7792

Seiko Instruments GmbH
OFC Division
Siemensstraße 9b
D-63263 Neu-Isenburg, Germany
Phone: +49-6102-297-0
Facsimile: +49-6102-297-211

Seiko Instruments (H.K.) Ltd.
Sales Department
4th & 5th Floor, Wyler Center 2
200 Tai Lin Pai Road, Kwai Chung
N.T., Kowloon, Hong Kong
Phone: +852-2421-8611
Facsimile: +852-2480-5479

Seiko Instruments Taiwan Inc.
Sales Department
4F, No.40, Sec. 2, Min Chuan E. Rd.,
Taipei 104, Taiwan, R.O.C.
Phone: +886-2-2563-5001
Facsimile: +886-2-2521-9519

Seiko Instruments Singapore pte. Ltd.
Component Sales Department
2, Marsiling Lane,
Singapore, 739144, Singapore
Phone: +65-269-1370
Facsimile: +65-269-9729

TABLE OF CONTENTS

Section	Page
1 PROVISION	1
1.1 Application limit	1
2 PARTS NUMBER	1
3 GENERAL SPECIFICATIONS	2
3.1 Parts and Materials	2
3.2 Physical Dimensions	2
3.3 General Tolerances	2
4 PACKING	2
5 NOTE	2

Table

Table 1	Parts Number	1
Table 2-1	Parts and Materials	2
Table 2-2	Parts and Materials of Main Body	2
Table 3	General Tolerance	2

Figure

Figure 1	SLC-P1 Connector Plug	3
Figure 2	Main Body	4
Figure 3 to 4	Parts Dimensions	5

1 PROVISION

1.1 Application Limit

These specifications apply to the SLC-P1 LC connector plug for \varnothing 0.9 mm supplied by SII.

2 PARTS NUMBER

Parts number of the connector plug is shown in Table 1.

Table 1 Parts Number

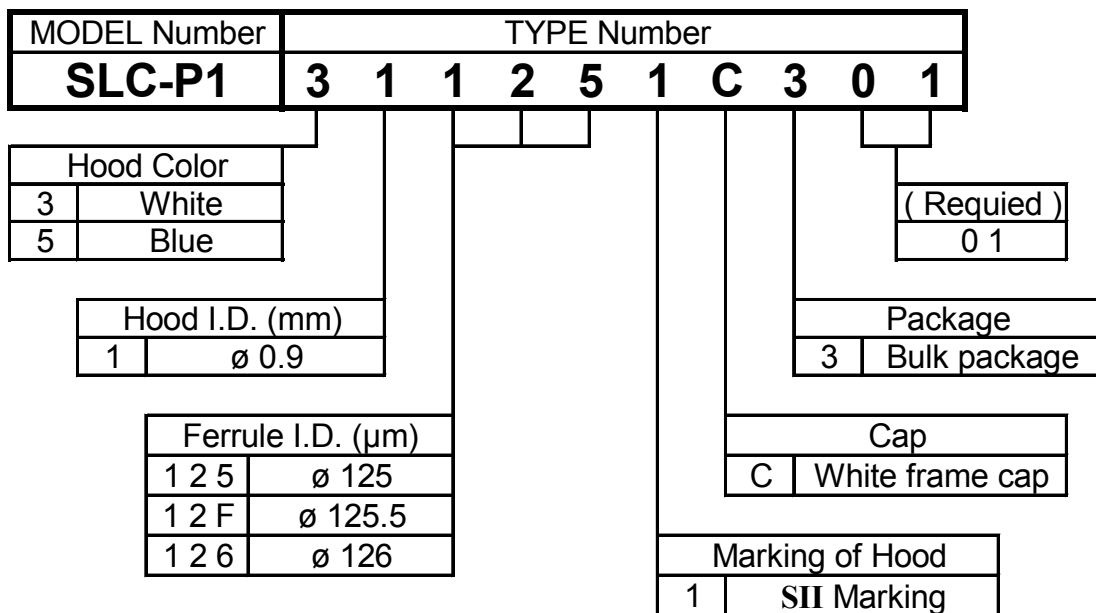

3 GENERAL SPECIFICATIONS

3.1 Parts and Materials

Parts and the materials are shown in Table 2-1 and 2-2.

Table 2-1 Parts and Materials

No.	Part Name	Qty	Material	Notes
①	Main body	1	See Table 2-2	Sub-assembled
②	Hood	1	TPE	UL94V-0
⑨	Cap	1	PP	White, UL94V-0

Table 2-2 Parts and Materials of Main Body

No.	Part Name	Qty	Material	Notes
③	Ferrule	1	Zirconia ceramics	-
④	Flange	1	Brass	Nickel plating
⑤	Tube	1	TPFE	Clear
⑥	Plug frame	1	PEI	Blue, UL94V-0
⑦	Spring	1	Stainless steel	-
⑧	Stopper	1	PBT GF	Blue, UL94V-0

3.2 Physical Dimensions

Figure 1 shows the assembled state of SLC-P1.

Figure 2 shows the Main body dimensions.

Figure 3 and 4 show the parts dimensions.

3.3 General Tolerances

Permissible deviation in dimensions without tolerance indication is in accordance with JIS B 0405 class m, as shown in Table 3.

Table 3 General tolerance (JIS B 0405 class m)

Basic size step [mm]		Permissible deviation [mm]
Over	Under	
0.5	3	±0.1
3	6	±0.1
6	30	±0.2
30	120	±0.3

4 PACKING

The product is packed to prevent damage during shipment.

5. NOTE

When discarding this product, please follow the regulations of your own country.

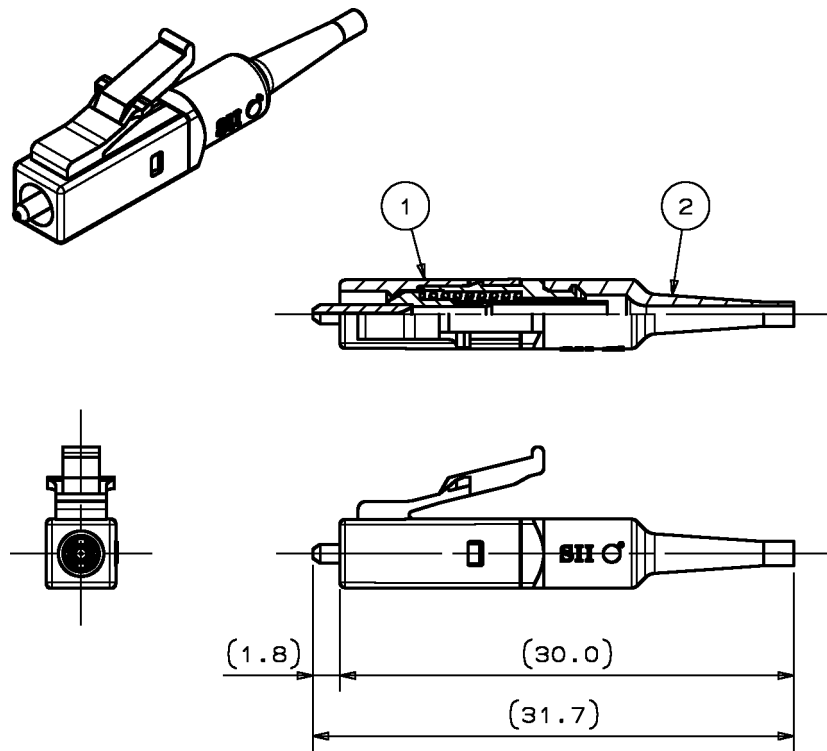

Notes 1: This drawing shows the tentatively assembled condition. In practice, the connector plug is not assembled like this.

2: This drawing does not include the cap.

Unit: mm

Figure 1 SLC-P1 Connector Plug

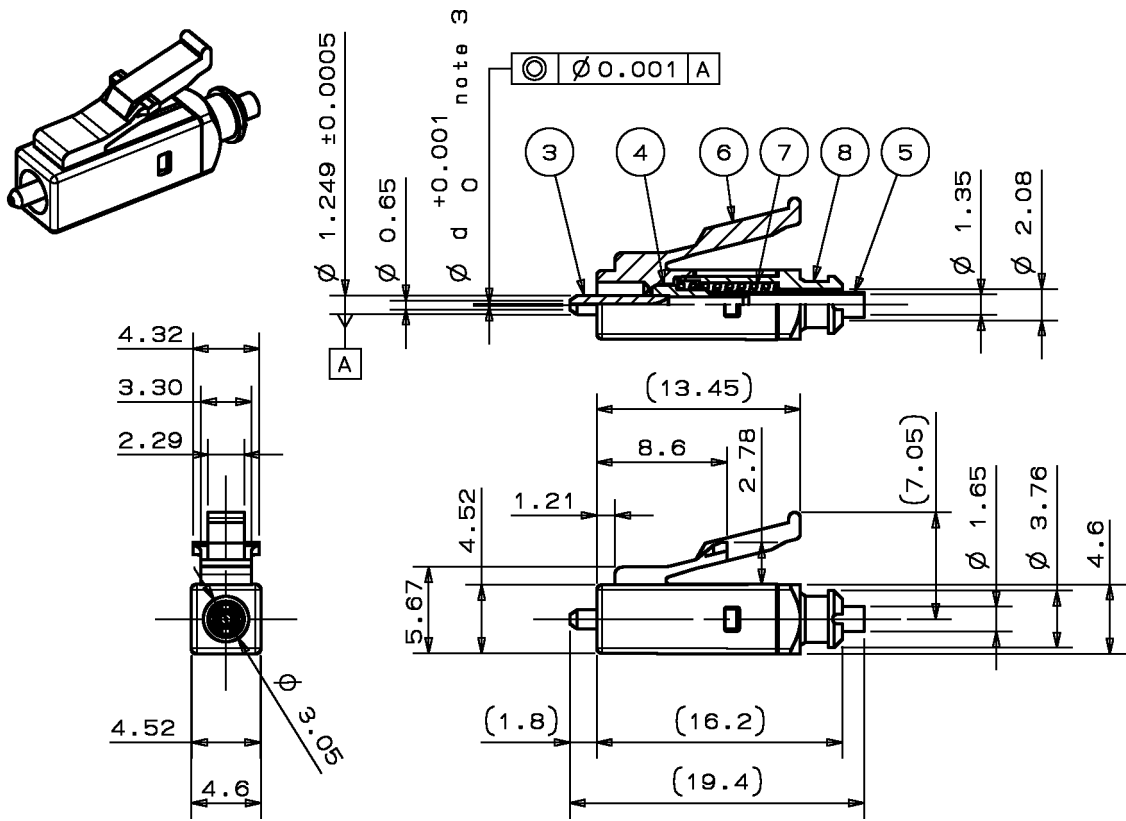

Note 3: Ferrule hole inner diameter (d) shown in Table 1.

Unit: mm

Figure 2 ① Main Body

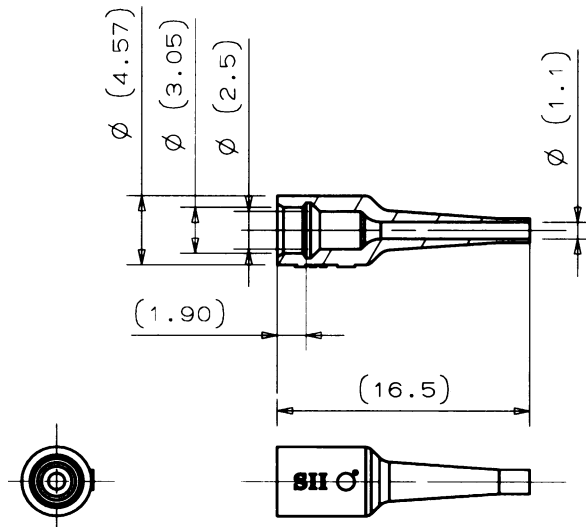

Figure 3 ② Hood

Unit: mm

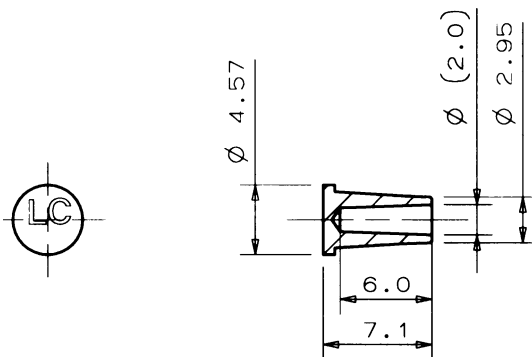

Figure 4 ⑨ Cap

Unit: mm