

# GSD

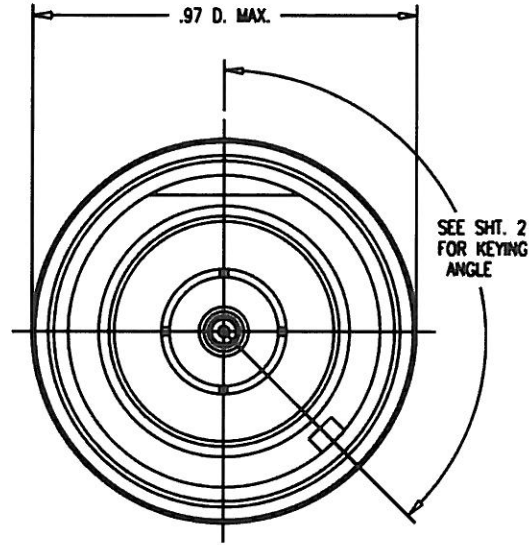
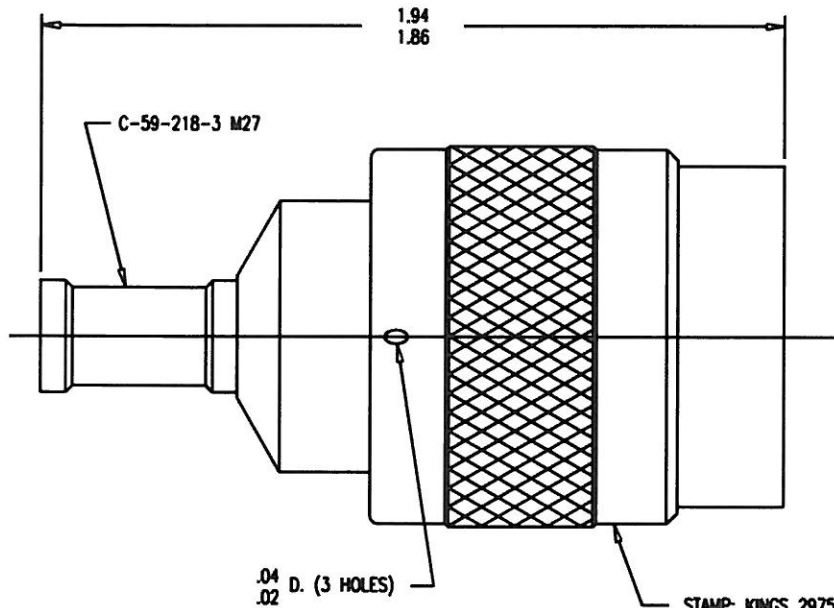

**NOTES:**

1. FOR USE WITH RG-142B, 223/U & TIMES AA-6343 CABLES.
2. FOR CABLING INSTRUCTIONS SEE CP-489.
3. FOR CRIMPING USE DIE KTH-2101.
4. INTERFACE PER MIL-STD-348, FIG. 304-1 (EX. KEYING).
5. CENTER CONTACT (1-547-30M9) SUPPLIED UNASSEMBLED.
6. MARK PACKAGE: KINGS 2975-4-\* YRWK (DATE CODE) SEE SHEET 2
7. MATERIALS:
  - INSULATOR-TEFLON, ASTM-D4894
  - C-RING-PHOS. BRONZE, ASTM-B103
  - GASKET-SILICONE RUBBER, A-A-59588
  - K-GRIP SLEEVE-COMMERCIAL BRONZE, ASTM-B135
  - OUTER CONTACT-BER. COP., ASTM-B-196
  - ALL OTHER METAL PARTS-BRASS, ASTM-B16
8. FINISHES:
  - CENTER CONTACT-GOLD PLATE PER ASTM-B488
  - OUTER CONTACT-SILVER PLATE PER ASTM-B700
  - ALL OTHER METAL PARTS-KINGS TARNISH RESISTANT FINISH (TR-5)
9. ELECTRICAL CHARACTERISTICS:
  - NOMINAL IMPEDANCE-50 OHMS
  - FREQUENCY RANGE-DC TO 11 GHZ
  - WORKING VOLTAGE-1000 VRMS

STAMP: KINGS 2975-2-\*  
YRWK (DATE CODE) SEE SHEET 2

# GSD

2975-2-\* (SHEET 1 OF 2)

REVISIONS	
ISSUE	CHANGES
0	ER 30586 MZB 03/10/89
1	CN 31058 A MZB 09/14/89
2	CN 39577 C JPK 08/16/06

29752SD1

SCALE 3:1	
APPROX SURFACE AREA	
WAS: E-15550	
USED ON	
REF: BOEING	
<b>PLUG, N (KEYED)</b>	
DRAWN MZB	DATE 03/09/89
DESIGN JT	DATE 03/10/89
APPR.	DATE

**KINGS**  
ELECTRONICS CO., INC.  
ROCK HILL, SOUTH CAROLINA 29730

2975-2-\*  
(SHEET 1 OF 2)

KINGS PART NO.	KEYING ANGLE
2975-2-1	42°
2975-2-2	54°
2975-2-3	66°
2975-2-4	78°
2975-2-5	90°
2975-2-6	102°
2975-2-7	114°
2975-2-8	126°
2975-2-9	138°
2975-2-10	150°
2975-2-11	162°
2975-2-12	174°
2975-2-13	186°
2975-2-14	198°
2975-2-15	210°
2975-2-16	222°
2975-2-17	234°
2975-2-18	246°
2975-2-19	258°
2975-2-20	270°
2975-2-21	282°
2975-2-22	294°
2975-2-23	306°
2975-2-24	318°

GSD

GSD

2975-2-\* (SHT 2 OF 2)

REVISIONS	
ISSUE	CHANGES
0	ER 30586 MZB 03/09/89
1	CN 31058 A MZB 09/14/89
2	CN 39577 C JPK 08/16/06

29752SD2

SCALE 1:1

APPROX SURFACE AREA

WAS: E-15550

USED ON

REF: BOEING

## ANGLE TABLE

DRAWN MZB DATE 03/09/89

DESIGN JT DATE 03/10/89

APPR. DATE

 **KINGS**  
ELECTRONICS CO., INC.  
ROCK HILL, SOUTH CAROLINA 29730

2975-2-\*  
(SHEET 2 OF 2)