

ALT02x TMR Analog Magnetometer Sensors

Equivalent Circuit

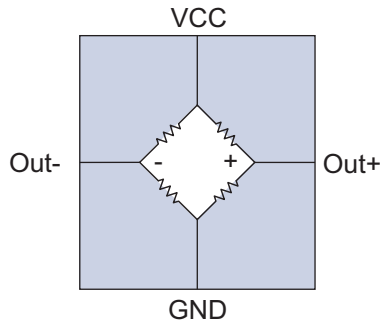

Transfer Function

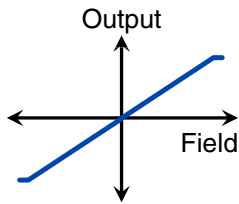

ALT02x Transfer Function.

Features

- Tunneling Magnetoresistive (TMR) technology
- Large signals (200 mV/V typ. full scale)
- ± 1 mT and ± 10 mT versions
- Highly linear output (< 1 %F.S.)
- Low temperature coefficient of output (± 0.1 %/°C)
- Up to 350 kHz frequency bandwidth
- 20 k Ω typ. device resistance for low power
- Operation to near-zero supply voltage
- Up to 125 °C operating temperature
- DFN6 or ultraminiature DFN4 packages

Applications

- Motion, speed, and position control
- Proximity sensing
- Noncontact current sensing
- Mechatronics and robotics
- Compassing

Description

ALT02x sensors are Tunneling Magnetoresistance (TMR) analog bridge sensors with an extraordinary amount of signal and wide linear range.

The differential bridge output is bipolar, meaning it is positive for a positive field and negative for an opposite field polarity.

The Wheatstone bridge configuration allows the sensors to be pure ratiometric devices. They operate at extremely low supply voltages and the output signal is proportional to the supply.

The output is stable over the operating temperature range of -40 to 125 °C.

Absolute Maximum Ratings

Parameter	Symbol	Min.	Typical	Max.	Units
Supply voltage	V_{CC}			7	Volts
Operating temperature	T_{min}, T_{max}		-40	125	°C
Storage temperature			-65	150	°C
ESD (Human Body Model) ¹				2000	Volts
Applied magnetic field ²	H			Unlimited	Tesla
Voltage from sensor connections to center pad				63	Volts DC

Operating Specifications

Parameter	Symbol	Min.	Typical	Max.	Units
Operating temperature	T	-40		125	°C
Supply voltage	V _{cc}	0		5.5	Volts
Offset voltage	V _{offset}	-20		20	mV/V
Device resistance	R	8	20	55	kΩ
Frequency bandwidth ³	f	DC		350	kHz
Operating field linear range ²					
ALT023	H	-1		1	mT
ALT025		-10		10	
Saturation field ²					
ALT023	H _{sat}		1.5		mT
ALT025			30		
Sensitivity ²					
ALT023	Sen	400	500		mV/V/mT
ALT025		6	20		
Field Detectivity ²					
1 Hz	H _{min}		30		nT/√Hz
5 kHz			0.7		
Hysteresis ⁴	H _c			1	%F.S.
Linearity ^{4,5}					
±20% of linear range, -40 – 85 °C	Lin		0.1	0.2	%F.S.
±50% of linear range, -40 – 85 °C			0.2	0.4	
±20% of linear range, -40 – 125 °C			0.2	0.5	
±50% of linear range, -40 – 125 °C			0.5	1	
Output at maximum operating field	V _{max}		200	400	mV/V
Temperature coefficient of device resistance ⁶	TCR		-0.08		%/°C
Temperature coefficient of output ⁶	TCO	-0.1	0	0.1	%/°C
Off-axis characteristic ⁷			Cos ² (β)		

Package Parameters	Symbol	Min.	Typical	Max.	Units
Junction–ambient thermal resistance ⁸					
ALT025-14E (DFN4)	θ _{JA}		500		°C/W
ALT02x-10E (DFN6)			320		
Power dissipation					
ALT025-14E (DFN4)	P _D		100		mW
ALT02x-10E (DFN6)			500		

Notes:

- Human Body Model (HBM) per JESD22-A114
- 1 millitesla (mT) = 10⁶nanotesla (nT) = 10 Gauss (G) = 10 Oersted (Oe) in air
- Specified for amplitude reduction of -3 dB.
- Full scale is defined as the operating field range.
- Maximum deviation from best linear fit. Excludes contributions from hysteresis.
- TCR is the device resistance change with temperature in constant applied field. TCO is the output change with temperature using either a constant current or constant voltage source to power the sensor.
- Beta (β) is any angle from the sensitive axis.
- Measured per JESD51 with ground pad not connected to circuit board.

Typical Performance Graphs

Figure 1 shows the typical response of the ALT025 TMR sensors.

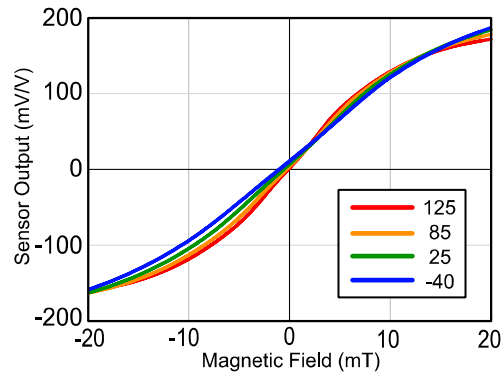

Figure 1. Typical ALT025 output at various temperatures.

Cross-Axis Directional Sensitivity

The ALT02x sensors have cross-axis sensitivity to magnetic fields, which corresponds to fields oriented from pad 1 to pad 4 or 6. This configuration is useful in current sensor applications where current-carrying circuit board traces oriented perpendicular to the sensitive direction produce magnetic fields in the sensitive direction while avoiding circuit board traces to the part.

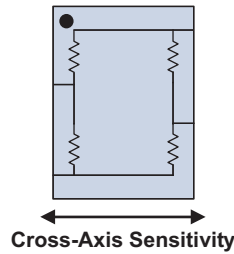

Figure 2. ALT02x sensor direction of sensitivity.

Bipolar

ALT02x sensors are bipolar as shown in Figure 3. The sensor output changes sign with the magnetic field direction. This is ideal for AC current sensing and many proximity-sensing applications. When the magnetic fields are oriented in the direction from pad 1 to pad 4 or 6 the sensor output ($V_{out+} - V_{out-}$) is positive.

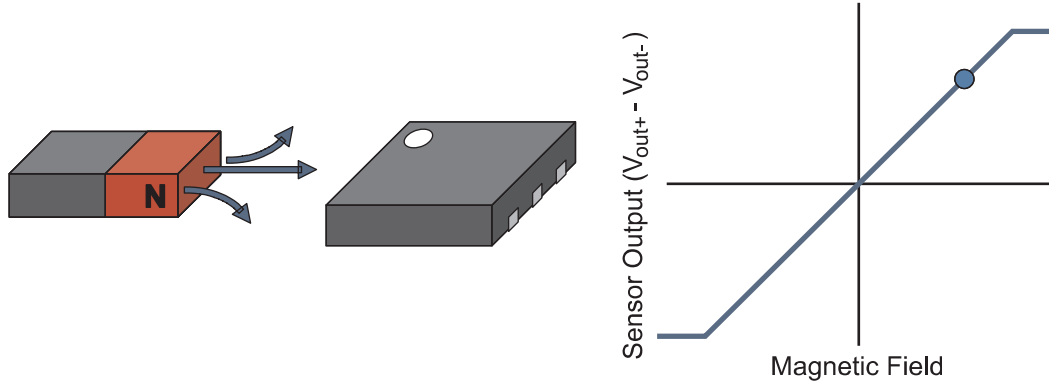

Figure 3. The ALT02x bipolar response.

The output of the sensor follows a $\cos(\theta)$ relationship, where θ is the angle between the sensor’s positive output sensitive direction and the applied field.

In-Plane Sensitivity

Unlike Hall Effect or other sensors, the direction of sensitivity of ALT02x sensors is in the plane of the package, which is more convenient for many applications. Two alternative permanent magnet orientations are shown in Figure 4.

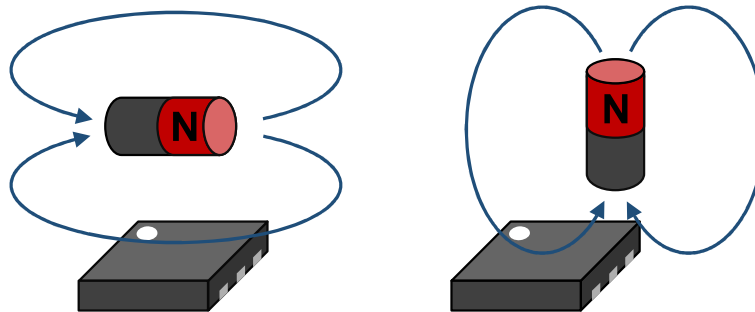

Figure 4. Planar magnetic sensitivity.

Minimum Magnetic Field Detectivity

ALT02x TMR sensors have a remarkably high sensitivity and low noise. These parameters define the sensor’s minimum detectable field. The noise spectrum of ALT02x sensors follows a classical $1/f$ noise profile at low frequency and is white noise at high frequency. Therefore, the detectivity varies with frequency. For more information, see NVE’s TMR magnetometer noise application note, SB-00-101.

Illustrative Applications

Dual-Supply Differential Amplifier

The ALT02x sensor's bipolar output is ideal for applications requiring positive and negative output voltages. The circuit below converts the output from differential to a single-ended positive or negative voltage. A low-cost, low bias-current op amp allows large resistors to avoid loading the sensor bridge. The 1 MΩ input resistors are 100 times the 10 kΩ sensor output impedance to avoid loading. The amplifiers in the example has a gain of five:

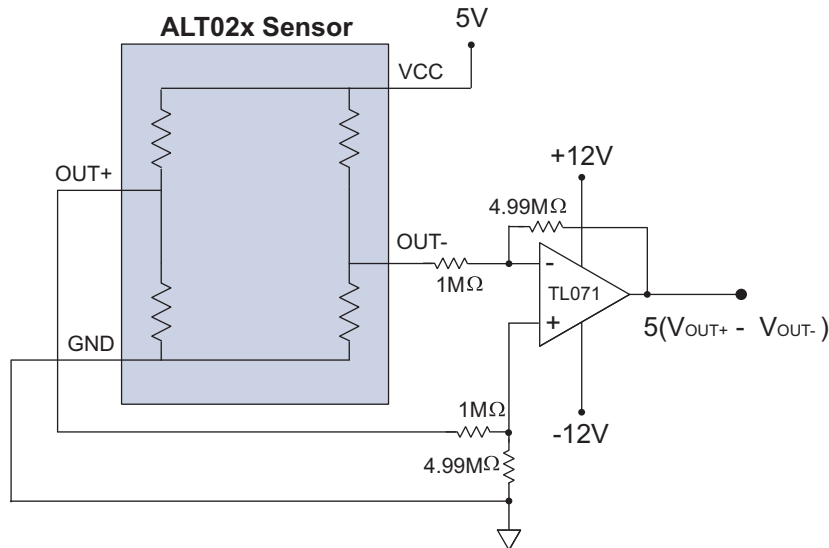

Figure 5. Dual-supply differential amplifier.

Single-Ended Instrumentation Amplifier

A circuit like the one below can be used to generate a positive, single-ended output. A voltage divider provides a 2.5 V reference voltage to center the amplifier output with zero field. Without the gain resistor, the gain is one and the output is 80% of rail-to-rail at the ±400 mV/V maximum output. A gain resistor can be added to increase the output, although this could narrow the usable field range.

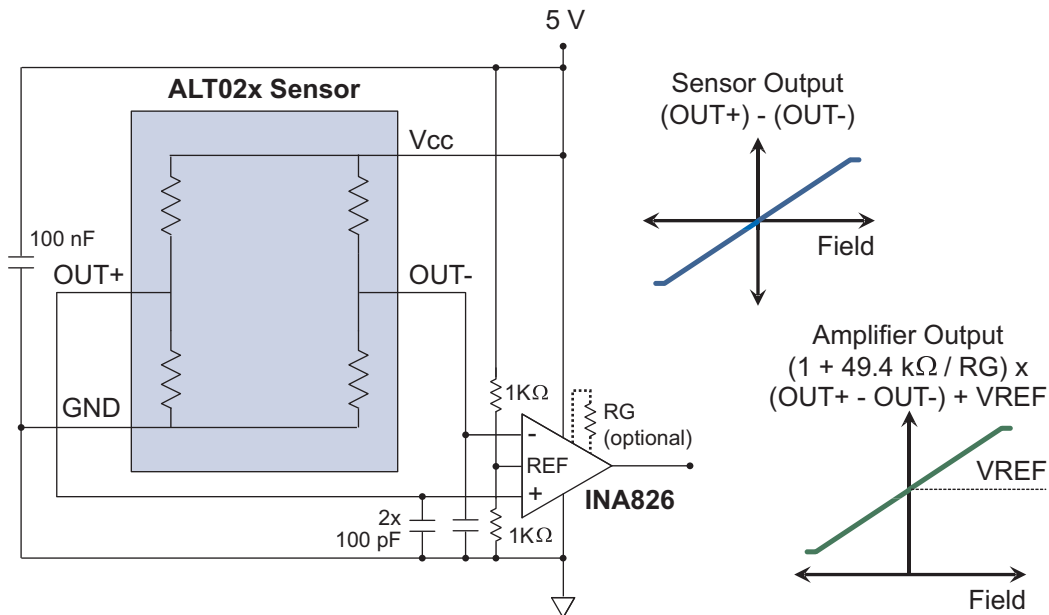

Figure 6. Single-ended analog sensor instrumentation amplifier.

Simple Direct Microcontroller Interfaces

With their large output signals, ALT02x sensors can often interface directly to microcontrollers, even the simple 10-bit ADCs built into inexpensive microcontrollers such as Atmel AVR[®]s. Such microcontrollers are common in Arduino and other sensor interface boards. The ALT02x's 20 kΩ typical device resistance provides 10 kΩ output impedances, ideal for direct interface to many microcontrollers:

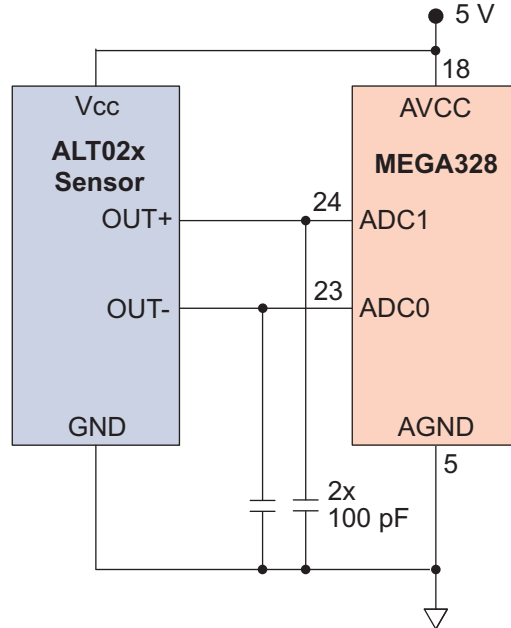

Figure 7. Typical direct microcontroller interface.

Here is an illustrative Arduino sketch:

```

/*****
Reads an analog magnetometer with an Arduino Uno.
Arduino-Sensor connections: A0 = sensor OUT-; A1 = OUT+; 5V = Vcc
www.nve.com * www.YouTube.com/NveCorporation * sensor-apps@nve.com
*****/
const float sens = 0.02; //Sensor sensitivity in V/V/mT
const int offset = 3; //Sensor offset (bits)
void setup() {
  Serial.begin(57600); //Initialize the serial port
}
void loop() { //Read, scale, & print sensor output.
  Serial.print(float(analogRead(A1)-analogRead(A0)-offset)/1024/sens);
  Serial.print(" mT \r" );
  delay(100); //10 samples/second
}

```

High-Resolution ADC Interface

A separate ADC can be used for higher resolution or higher speed than a typical direct microcontroller interface. The following circuit uses a 24-bit ADC that can be clocked at up to 20 MHz, and uses the ADC’s two-wire interface mode for simple wiring:

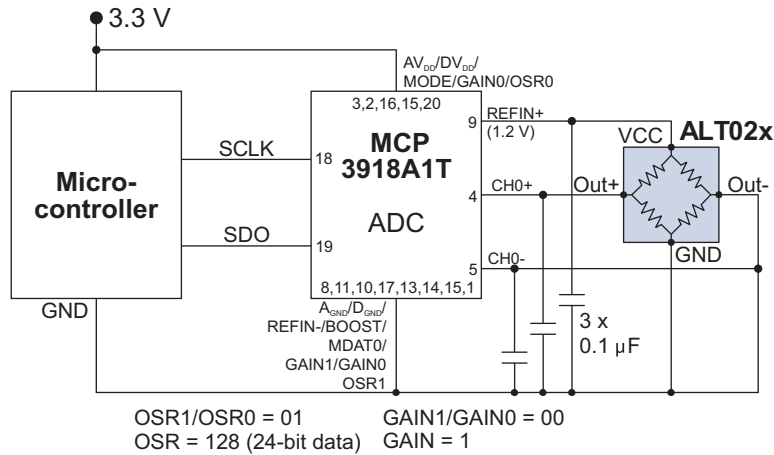

Figure 8. Typical high-resolution ADC interface.

The sensor is low power and has no minimum supply voltage, so it can be powered by the 1.2-volt ADC reference. Since sensor is ratiometric, reference variations and noise cancel. Additionally, the sensor output is differential, which further increases the Common-Mode Rejection Ratio.

Magnetic Switch Using a Comparator

ALT02x sensors can be combined with simple comparators to form magnetic switches. Like NCS2200 comparators, the sensors have no minimum supply voltages, and because they are ratiometric, power supply variations cancel. This makes the sensors ideal for battery-powered applications:

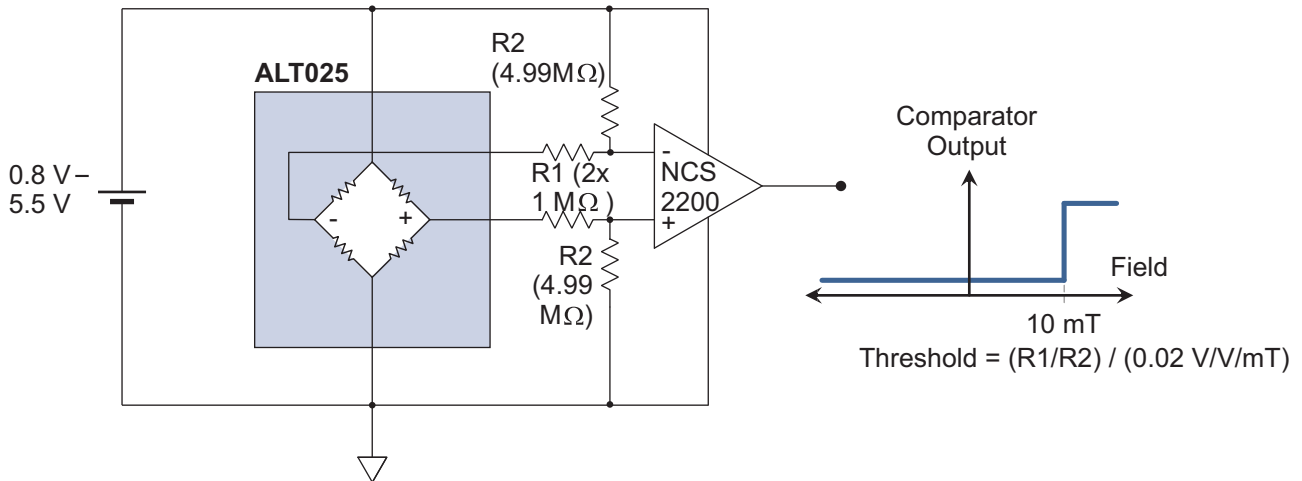

Figure 9. An adjustable magnetic switch using an ALT025 and a comparator.

The matched resistors in the circuit above preserve the sensor bridge’s inherent cancellation of temperature and power supply variations. The switching threshold is set by the R1/R2 ratio (1/5 in the example above), combined with the sensor’s sensitivity (20 mV/V/mT or 0.02 V/V/mT for the ALT025 sensor). The relatively large resistors avoid loading the bridge. Since the sensor has a bipolar magnetic response, the comparator only switches with a large enough field of the correct polarity.

The circuit above has only the small amount of hysteresis provided by the comparator, so the comparator output could “chatter” around the switching point in some applications. Hysteresis can be added in the following circuit.

Adding Comparator Hysteresis

A positive feedback resistor on the comparator adds hysteresis:

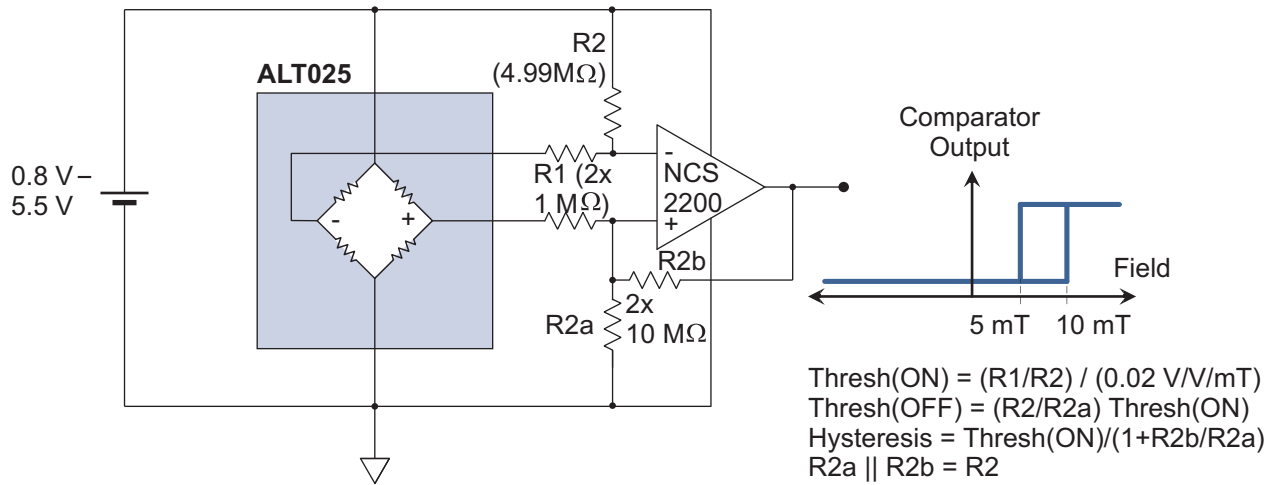

Figure 9. Magnetic switch with added hysteresis.

LED Field-Strength Indicator

The ALT02x's true bipolar output allows detection of field polarity. The op-amp circuit below detects the polarity of the magnetic field and change brightness to show field strength at a glance:

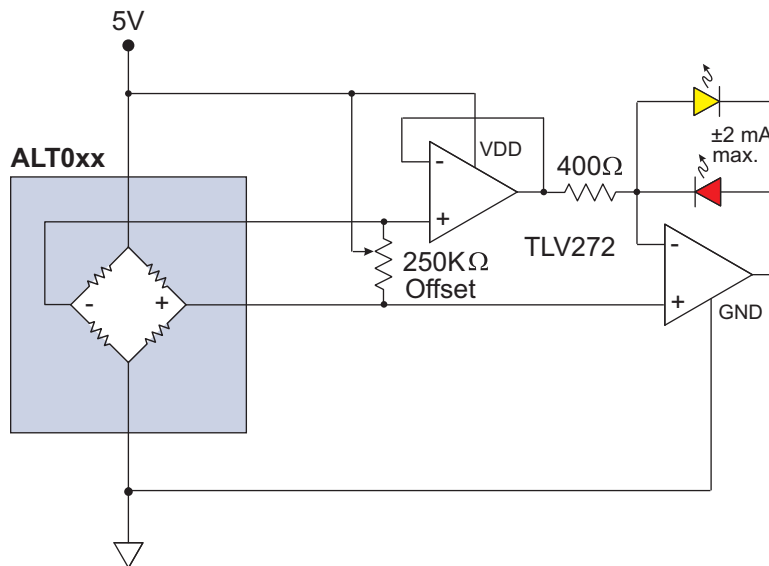

Figure 11. LED brightness indicates the magnetic field and color indicates polarity.

A positive field turns on the red LED and a negative field turns on the yellow LED. The 250 kΩ potentiometer is optional to correct sensor offset.

Noncontact Current Sensing

With low hysteresis, high linearity at low fields, and high speed, ALT02x sensors are ideal for noncontact current measurement. Due to their convenient in-plane sensitivity, they can be mounted directly over PCB traces. The sensor measures the current by detecting the magnetic field generated by the current through the trace.

These sensors feature cross-axis sensitivity, so they are able to detect current traces directly beneath the part for maximum accuracy. These sensors have a wide linear range, so they can detect a wide range of currents. By tailoring the PCB trace to the application, they can detect currents from 0.1 mA to 250 A.

Two typical high-resolution current sensing configurations are shown below. The current trace runs directly under the sensor on a single side of the PCB.

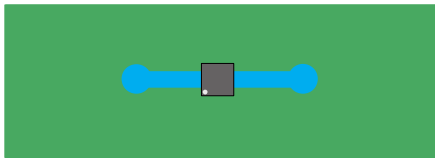

Figure 10a. 0.05" (1.3 mm) trace for currents 0 – 5 A.

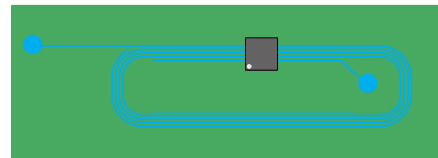

Figure 10b. Five turns of 0.0055" (0.14 mm) trace for currents 0 – 1 A.

The generated magnetic field is easily calculated with Ampere’s Law:

$$H = 5nI \quad \text{[“H” in oersteds and “I” in amps. “n” is the number of turns.]}$$

For high current sensing, larger traces are required. The sensor is typically mounted opposite a high current trace on a standard PCB, as shown in Figure 1. In this case, the width of the trace is significant, and a formula can be obtained by breaking the trace into a finite element array of thin traces, and calculating the field from each array element.

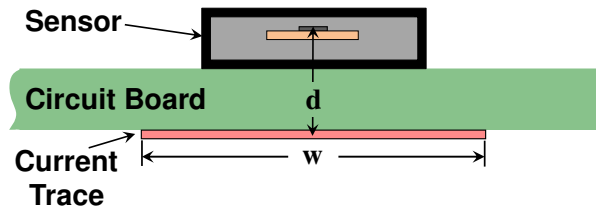

Figure 1. The geometry of current sensing over a circuit board trace. Depending on the trace’s width and thickness, currents up to 250 A can be measured.

$$H = \frac{4I}{w} \cdot \arctan \left[\frac{w}{2d} \right] \quad \text{[“H” in oersteds, “I” in amps, “d” in millimeters includes half of the package thickness, and “w” in millimeters.]}$$

To simplify these calculations, we have a free, Web-based application with these formulas to calculate magnetic fields and sensor outputs in current-sensing applications:

www.nve.com/spec/calculators.php#tabs-Current-Sensing

To help with the design of high current traces for current sensing applications, see our application note, which provides a comprehensive guide.

www.nve.com/Downloads/SB-00-083_Precision_High_Current_Sensing_Over_PCB_Traces.pdf

1.1 mm x 1.1 mm DFN4 Package (-14E suffix)

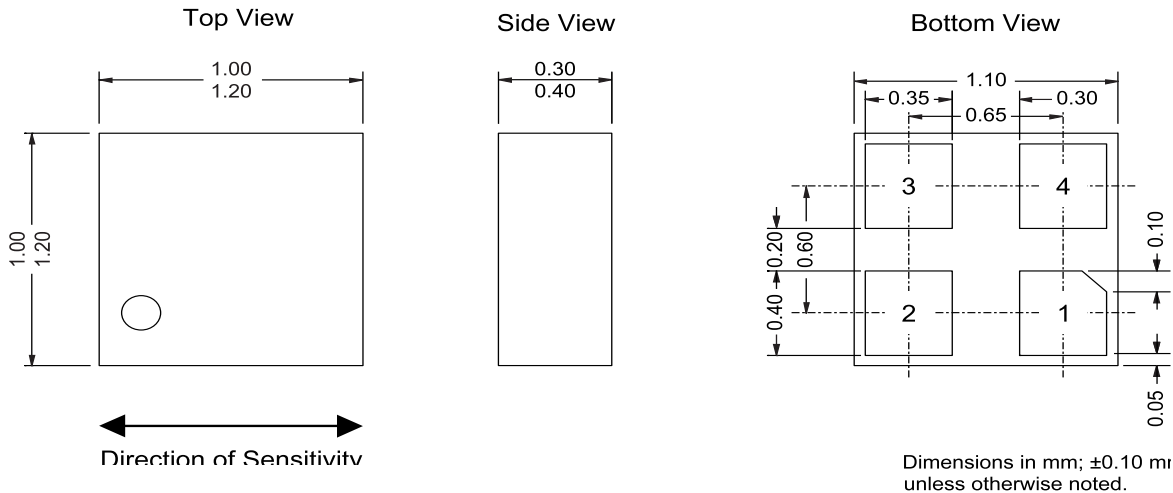

2.5 mm x 2.5 mm DFN6 Package (-10 suffix)

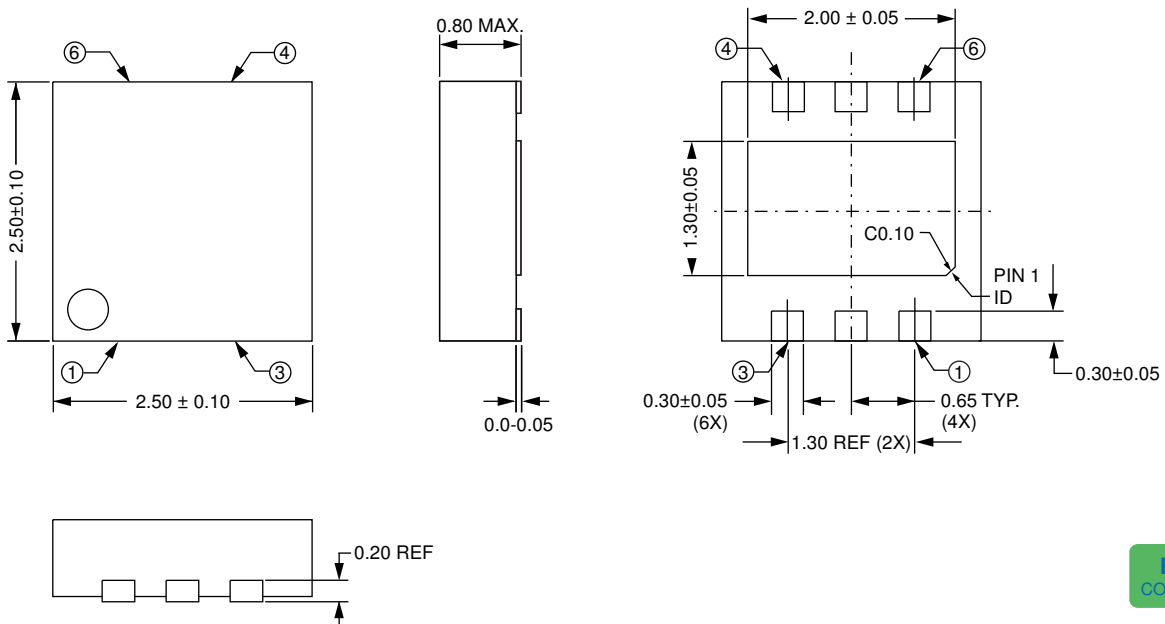

Notes:

- Dimensions in millimeters.
- Soldering profile per JEDEC J-STD-020C, MSL 1.

Functional Diagram and Pinout

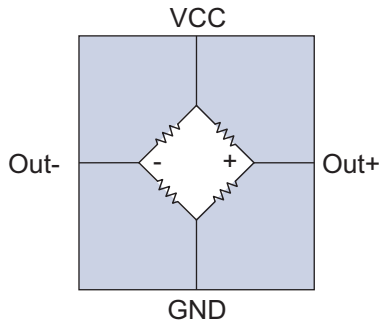

Symbol	Description	Pad #	
		DFN4	DFN6
V _{cc}	Positive bridge supply.	2	6
GND	Negative bridge supply or ground.	4	3
Out+	Positive bridge output.	1	1
Out-	Negative bridge output.	3	4
NC	No internal connection.		2, 5
-	Internally connected to leadframe	N/A	Center Pad

Part Numbering

ALT025-10E

Base Part

ALT = Analog TMR
Magnetometer Sensors

Sensitivity Direction

02 = Cross-Axis

Linear Range

3 = ±1 mT
5 = ±10 mT

Package Type

14 = 1.1 x 1.1 mm DFN4
10 = 2.5 x 2.5 mm DFN6
E = RoHS

Available Parts

Part Number	Linear Range	Package	Package Marking
ALT023-10E	±1.5 mT	2.5 x 2.5 mm DFN6	FGH
ALT025-10E	±10 mT	2.5 x 2.5 mm DFN6	FHC
ALT025-14E	±10 mT	1.1 x 1.1 mm DFN4	x

Bare Circuit Boards

NVE offers bare circuit boards for easy connections to DFN4 and DFN6 sensors such as the ALT02x series:



AG904-06: DFN4 connection board for -14E suffix sensors.
(1.2" x 0.25" / 30 mm x 6 mm; actual size).



AG935-06: DFN6 connection board for -10E suffix sensors.
(1.57" x 0.25" / 40 mm x 6 mm; actual size).

Current Sensor Evaluation Board

This demonstration board shows the ALT025's remarkable linear range and accuracy for up to ± 200 A noncontact current measurement:

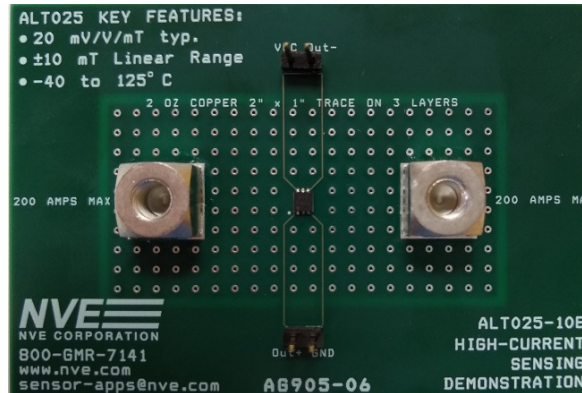

AG905-07E: ALT025-10E High-Current Demonstration Board
(3" x 2.065" / 76 mm x 52 mm; actual size).

Revision History

SB-00-102 – Rev. F

July 2021

Changes

- Added high-sensitivity version (ALT023-10E).
- Added DFN4 version (ALT025-14E).
- Dropped “standard-axis” version (ALT005).
- Added instrumentation amplifier gain equation (Fig. 6).
- Added illustrative Arduino program.
- 24-bit ADC application circuit (Fig. 8).
- Comparator application circuits (Figs. 9 and 10).

SB-00-102 – Rev. E

April 2020

Change

- Increased maximum resistance rating for lower power.

SB-00-102 – Rev. D

November 2019

Change

- Added ALT005 part for standard-axis sensitivity.
- Updates and clarifications for standard axis and cross-axis sensitivities.

SB-00-102 – Rev. C

August 2019

Change

- Revised Fig. 4 (p. 4).
- Added AG905-07E current sensing demonstration board (p. 9).
- Minor typographical changes.

SB-00-102 – Rev. B

June 2019

Change

- Added part marking.
- Added minimum sensor detectivity.
- Clarified definition of full scale and corrected offset specification.

SB-00-102 – Rev. A

June 2019

Change

- Clarified connections on application circuits.
- Increased typical sensitivity consistent with test data.

SB-00-102– Prelim

June 2019

Change

- Preliminary release.

Datasheet Limitations

The information and data provided in datasheets shall define the specification of the product as agreed between NVE and its customer, unless NVE and customer have explicitly agreed otherwise in writing. All specifications are based on NVE test protocols. In no event however, shall an agreement be valid in which the NVE product is deemed to offer functions and qualities beyond those described in the datasheet.

Limited Warranty and Liability

Information in this document is believed to be accurate and reliable. However, NVE does not give any representations or warranties, expressed or implied, as to the accuracy or completeness of such information and shall have no liability for the consequences of use of such information.

In no event shall NVE be liable for any indirect, incidental, punitive, special or consequential damages (including, without limitation, lost profits, lost savings, business interruption, costs related to the removal or replacement of any products or rework charges) whether or not such damages are based on tort (including negligence), warranty, breach of contract or any other legal theory.

Right to Make Changes

NVE reserves the right to make changes to information published in this document including, without limitation, specifications and product descriptions at any time and without notice. This document supersedes and replaces all information supplied prior to its publication.

Use in Life-Critical or Safety-Critical Applications

Unless NVE and a customer explicitly agree otherwise in writing, NVE products are not designed, authorized or warranted to be suitable for use in life support, life-critical or safety-critical devices or equipment. NVE accepts no liability for inclusion or use of NVE products in such applications and such inclusion or use is at the customer's own risk. Should the customer use NVE products for such application whether authorized by NVE or not, the customer shall indemnify and hold NVE harmless against all claims and damages.

Applications

Applications described in this datasheet are illustrative only. NVE makes no representation or warranty that such applications will be suitable for the specified use without further testing or modification.

Customers are responsible for the design and operation of their applications and products using NVE products, and NVE accepts no liability for any assistance with applications or customer product design. It is customer's sole responsibility to determine whether the NVE product is suitable and fit for the customer's applications and products planned, as well as for the planned application and use of customer's third party customers. Customers should provide appropriate design and operating safeguards to minimize the risks associated with their applications and products.

NVE does not accept any liability related to any default, damage, costs or problem which is based on any weakness or default in the customer's applications or products, or the application or use by customer's third party customers. The customer is responsible for all necessary testing for the customer's applications and products using NVE products in order to avoid a default of the applications and the products or of the application or use by customer's third party customers. NVE accepts no liability in this respect.

Limiting Values

Stress above one or more limiting values (as defined in the Absolute Maximum Ratings System of IEC 60134) will cause permanent damage to the device. Limiting values are stress ratings only and operation of the device at these or any other conditions above those given in the recommended operating conditions of the datasheet is not warranted. Constant or repeated exposure to limiting values will permanently and irreversibly affect the quality and reliability of the device.

Terms and Conditions of Sale

In case an individual agreement is concluded only the terms and conditions of the respective agreement shall apply. NVE hereby expressly objects to applying the customer's general terms and conditions with regard to the purchase of NVE products by customer.

No Offer to Sell or License

Nothing in this document may be interpreted or construed as an offer to sell products that is open for acceptance or the grant, conveyance or implication of any license under any copyrights, patents or other industrial or intellectual property rights.

Export Control

This document as well as the items described herein may be subject to export control regulations. Export might require a prior authorization from national authorities.

Automotive Qualified Products

Unless the datasheet expressly states that a specific NVE product is automotive qualified, the product is not suitable for automotive use. It is neither qualified nor tested in accordance with automotive testing or application requirements. NVE accepts no liability for inclusion or use of non-automotive qualified products in automotive equipment or applications.

In the event that customer uses the product for design-in and use in automotive applications to automotive specifications and standards, customer (a) shall use the product without NVE's warranty of the product for such automotive applications, use and specifications, and (b) whenever customer uses the product for automotive applications beyond NVE's specifications such use shall be solely at customer's own risk, and (c) customer fully indemnifies NVE for any liability, damages or failed product claims resulting from customer design and use of the product for automotive applications beyond NVE's standard warranty and NVE's product specifications.

An ISO 9001 Certified Company

NVE Corporation
11409 Valley View Road
Eden Prairie, MN 55344-3617 USA
Telephone: (952) 829-9217
www.nve.com
www.youtube.com/NveCorporation

e-mail: sensor-info@nve.com

©NVE Corporation

All rights are reserved. Reproduction in whole or in part is prohibited without the prior written consent of the copyright owner.