

T-46-07-11



DM74AS533 Octal D-Type Transparent Latch with TRI-STATE® Outputs

General Description

These 8-bit registers feature totem-pole TRI-STATE outputs designed specifically for driving highly-capacitive or relatively low-impedance loads. The high-impedance state and increased high-logic-level drive provide these registers with the capability of being connected directly to and driving the bus lines in a bus-organized system without need for interface or pull-up components. They are particularly attractive for implementing buffer registers, I/O ports, bidirectional bus drivers, and working registers.

The eight inverting latches of the AS533 are transparent D-type latches, meaning that while the enable (G) is high the \bar{Q} outputs will follow the complement of the data (D) inputs. When the enable is taken low the output will be latched at the complement of the level of the data that was set up.

A buffered output control input can be used to place the eight outputs in either a normal logic state (high or low logic

levels) or a high-impedance state. In the high-impedance state the outputs neither load nor drive the bus lines significantly.

The output control does not affect the internal operation of the latches. That is, the old data can be retained or new data can be entered even while the outputs are off.

Features

- Switching specifications at 50 pF
- Switching specifications guaranteed over full temperature and V_{CC} range
- Advanced oxide-isolated, ion-implanted Schottky TTL process
- TRI-STATE buffer-type outputs drive bus lines directly

Connection Diagram

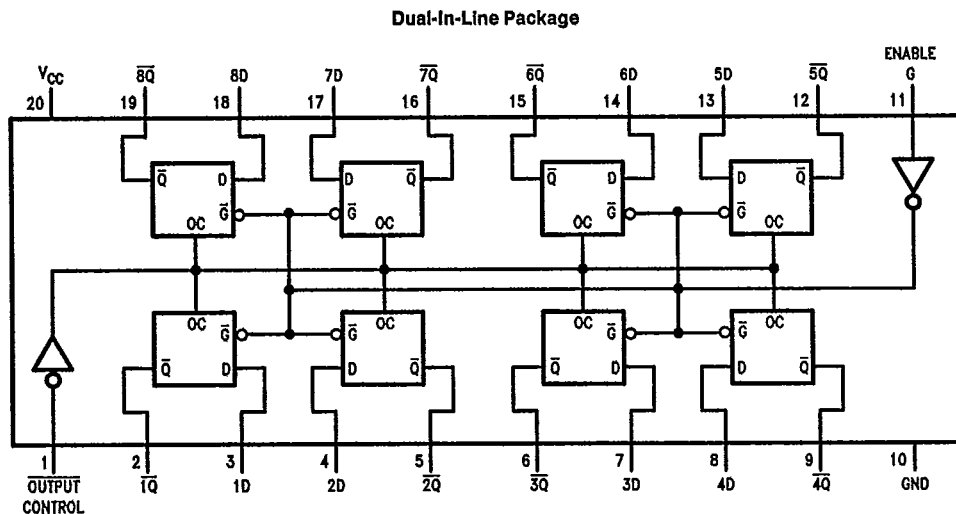

Order Number DM74AS533WM or DM74AS533N
See NS Package Number M20B or N20A

TL/F/6311-1



533

Absolute Maximum Ratings

Supply Voltage	7V
Input Voltage	7V
Voltage Applied to Disabled Output	5.5V
Operating Free Air Temperature Range	0°C to +70°C
Storage Temperature Range	-65°C to +150°C
Typical θ_{JA}	
N Package	52.5°C/W
M Package	70.5°C/W

T-46-07-11

Note: The "Absolute Maximum Ratings" are those values beyond which the safety of the device cannot be guaranteed. The device should not be operated at these limits. The parametric values defined in the "Electrical Characteristics" table are not guaranteed at the absolute maximum ratings. The "Recommended Operating Conditions" table will define the conditions for actual device operation.

Recommended Operating Conditions

Symbol	Parameter	Min	Nom	Max	Units
V _{CC}	Supply Voltage	4.5	5	5.5	V
V _{IH}	High Level Input Voltage	2			V
V _{IL}	Low Level Input Voltage			0.8	V
I _{OH}	High Level Output Current			-15	mA
I _{OL}	Low Level Output Current			48	mA
t _w	Width of Enable Pulse, High or Low	2			ns
t _{SU}	Data Setup Time	2 ↑			ns
t _H	Data Hold Time	3 ↑			ns
T _A	Free Air Operating Temperature	0		70	°C

The (↑) arrow indicates the positive edge of the Clock is used for reference.

Electrical Characteristics

over recommended operating free air temperature range. All typical values are measured at V_{CC} = 5V, T_A = 25°C.

Symbol	Parameter	Conditions	Min	Typ	Max	Units	
V _{IK}	Input Clamp Voltage	V _{CC} = 4.5V, I _I = -18 mA			-1.2	V	
V _{OH}	High Level Output Voltage	V _{CC} = 4.5V, I _{OH} = Max	2.4	3.2		V	
		I _{OH} = -2 mA, V _{CC} = 4.5V to 5.5V	V _{CC} - 2				
V _{OL}	Low Level Output Voltage	V _{CC} = 4.5V, I _{OL} = Max		0.35	0.5	V	
I _I	Input Current @ Max Input Voltage	V _{CC} = 5.5V, V _{IH} = 7V			0.1	mA	
I _{IH}	High Level Input Current	V _{CC} = 5.5V, V _{IH} = 2.7V			20	μA	
I _{IL}	Low Level Input Current	V _{CC} = 5.5V, V _{IL} = 0.4V			-0.5	mA	
I _O	Output Drive Current	V _{CC} = 5.5V, V _O = 2.25V	-30		-112	mA	
I _{OZH}	Off-State Output Current, High Level Voltage Applied	V _{CC} = 5.5V, V _O = 2.7V			50	μA	
I _{OZL}	Off-State Output Current, Low Level Voltage Applied	V _{CC} = 5.5V, V _O = 0.4V			-50	μA	
I _{CC}	Supply Current	V _{CC} = 5.5V Outputs Open	Outputs High	62	100	mA	
			Outputs Low		64		100
			Outputs Disabled		71		110

T-46-07-11

533

Switching Characteristics over recommended operating free air temperature range (Note 1)

Symbol	Parameter	Conditions	From	To	Min	Max	Units
t_{PLH}	Propagation Delay Time Low to High Level Output	$V_{CC} = 4.5V$ to $5.5V$ $R_L = 500\Omega$ $C_L = 50 pF$	Data	Any \bar{Q}	4	7.5	ns
t_{PHL}	Propagation Delay Time High to Low Level Output		Data	Any \bar{Q}	4	7	ns
t_{PLH}	Propagation Delay Time Low to High Level Output		Enable	Any \bar{Q}	6	9	ns
t_{PHL}	Propagation Delay Time High to Low Level Output		Enable	Any \bar{Q}	4.5	8	ns
t_{pZH}	Output Enable Time to High Level Output		Output Control	Any \bar{Q}	2	6.5	ns
t_{pZL}	Output Enable Time to Low Level Output		Output Control	Any \bar{Q}	4.5	9.5	ns
t_{PHZ}	Output Disable Time from High Level Output		Output Control	Any \bar{Q}	3	6.5	ns
t_{PLZ}	Output Disable Time from Low Level Output		Output Control	Any \bar{Q}	3	7	ns

Note 1: See Section 1 for test waveforms and output load.

Logic Diagram

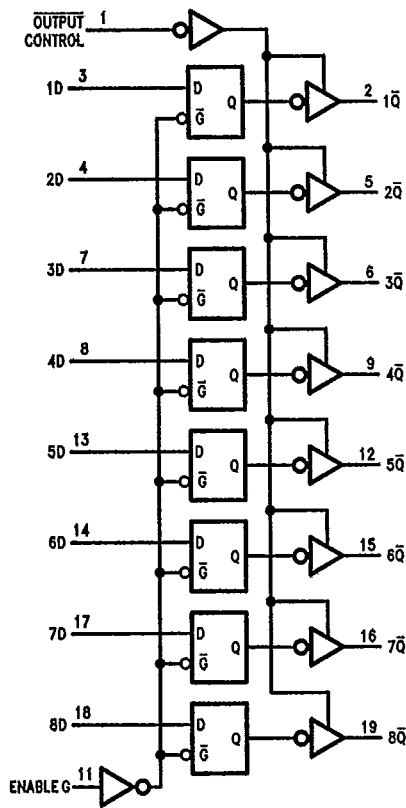

TL/F/6311-2

Function Table

Output Control	Enable G	D	Output \bar{Q}
L	H	H	L
L	H	L	H
L	L	X	\bar{Q}_0
H	X	X	Z

L = Low State, H = High State, X = Don't Care
Z = High Impedance State
 \bar{Q}_0 = Previous Condition of \bar{Q}

