

Octal bus transceiver/register (3-State)

74AC646
74ACT646

FEATURES

- 74ACT646 has TTL-compatible inputs
- 74AC646 has CMOS-compatible inputs
- 3-State outputs source/sink 24mA
- 3-State outputs drive bus lines or buffer memory address registers
- Meets or exceeds JEDEC standard for 74AC(T)XX family
- Superior ground bounce noise immunity

DESCRIPTION

The 74AC646/74ACT646 is an octal bus transceiver/register consisting of non-inverting bus transceiver circuits with 3-State outputs, D-type flip-flops and control circuitry arranged for multiplexed transmission of data directly from the internal registers.

Data on the 'A' or 'B' bus will be clocked in the internal registers, as the appropriate clock (CP_{AB} or CP_{BA}) goes to a HIGH logic level. Output enable (\overline{OE}) and direction (DIR) inputs are provided to control the transceiver function. In the transceiver mode, data present at the high-impedance port may be stored in either the 'A' or 'B' register, or in both. The select source inputs (S_{AB} and S_{BA}) can multiplex stored and real-time (transparent mode) data.

The direction (DIR) input determines which bus will receive data when \overline{OE} is active (LOW). In the isolation mode (OE = HIGH), 'A' data may be stored in the 'B' register and/or 'B' data may be stored in the 'A' register.

When an output function is disabled, the input function is still enabled and may be used to store and transmit data. Only one of the two buses, 'A' or 'B' may be driven at a time.

The '646' is functionally identical to the '648' but has non-inverting data paths.

QUICK REFERENCE DATA

GND = 0V; T_{amb} = 25°C; t_r = t_f ≤ 2.5 ns

SYMBOL	PARAMETER	CONDITIONS	TYPICAL			UNIT
			AC		ACT	
			V _{CC} = 3.3V	V _{CC} = 5.0V	V _{CC} = 5.0V	
t _{PLH} /t _{PHL}	Propagation delay An, Bn to Bn, An; CP _{AB} , CP _{BA} to Bn, An; S _{AB} , S _{BA} to Bn, An	C _L = 50pF	5.1 6.0 6.5	3.5 4.2 4.6	5.8 5.9 6.6	ns
C _I	Input capacitance		4.5			pF
C _{PD}	Power dissipation capacitance per channel	V _{in} = GND to V _{CC} ¹ outputs enabled outputs disabled	33 6		30 6	pF

NOTES:

1. C_{PD} is used to determine the dynamic power dissipation (P_D in μW)

$P_D = C_{PD} \times V_{CC}^2 \times f_i + \sum (C_L \times V_{CC}^2 \times f_o)$ where:

f_i = input frequency in MHz; C_L = output load capacity in pF;

f_o = output frequency in MHz; V_{CC} = supply voltage in V;

$\sum (C_L \times V_{CC}^2 \times f_o)$ = sum of the outputs.

ORDERING AND PACKAGE INFORMATION

PACKAGES	TEMPERATURE RANGE	OUTSIDE NORTH AMERICA	NORTH AMERICA	PKG. DWG. #
24-Pin Plastic SO	-40°C to +85°C	74AC646 D 74ACT646 D	74AC646 D 74ACT646 D	SOT137-1
24-Pin Plastic SSOP Type II	-40°C to +85°C	74AC646 DB 74ACT646 DB	74AC646 DB 74ACT646 DB	SOT340-1
24-Pin Plastic TSSOP Type I	-40°C to +85°C	74AC646 PW 74ACT646 PW	74AC646PW DH 74ACT646PW DH	SOT355-1

Octal bus transceiver/register (3-State)

74AC646
74ACT646

PIN DESCRIPTION

PIN NUMBER	SYMBOL	FUNCTION
1	CP _{AB}	'A' to 'B' clock input (LOW-to-HIGH, edge-triggered)
2	S _{AB}	Select 'A' to 'B' source input
3	DIR	Direction control input
4, 5, 6, 7, 8, 9, 10, 11	A ₀ to A ₇	'A' data inputs/outputs
12	GND	Ground (0V)
20, 19, 18, 17, 16, 15, 14, 13	B ₀ to B ₇	'B' data inputs/outputs
21	\overline{OE}	Output enable input (active LOW)
22	S _{BA}	Select 'B' to 'A' source input
23	CP _{BA}	'B' to 'A' clock input (LOW-to-HIGH, edge-triggered)
24	V _{CC}	Positive supply voltage

PIN CONFIGURATION

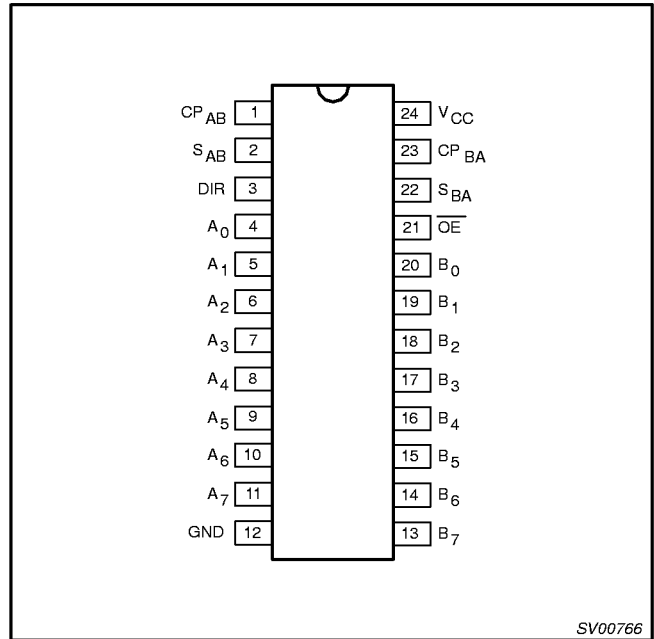

SV00766

FUNCTION TABLE

INPUTS						DATA I/O *		FUNCTION
\overline{OE}	DIR	CP _{AB}	CP _{BA}	S _{AB}	S _{BA}	A ₀ to A ₇	B ₀ to B ₇	
X	X	↑	X	X	X	input	un *	Store A, B unspecified * Store B, A unspecified *
X	X	X	↑	X	X	un *	input	
H	X	↑	↑	X	X	input	input	Store A and B data, Isolation hold storage
H	X	H or L	H or L	X	X			
L	L	X	X	X	L	output	input	Real-time B data to A bus Stored B data to A bus
L	L	X	H or L	X	H			
L	H	X	X	L	X	input	output	Real-time A data to B bus Stored A data to B bus
L	H	H or L	X	H	X			

* The data output functions may be enabled or disabled by various signals at the \overline{OE} and DIR inputs. Data input functions are always enabled, i.e., data at the bus inputs will be stored on every LOW-to-HIGH transition on the clock inputs.

- un = unspecified
- H = HIGH voltage level
- L = LOW voltage level
- X = Don't care
- ↑ = LOW-to-HIGH level transition

Octal bus transceiver/register (3-State)

74AC646
74ACT646

LOGIC SYMBOL

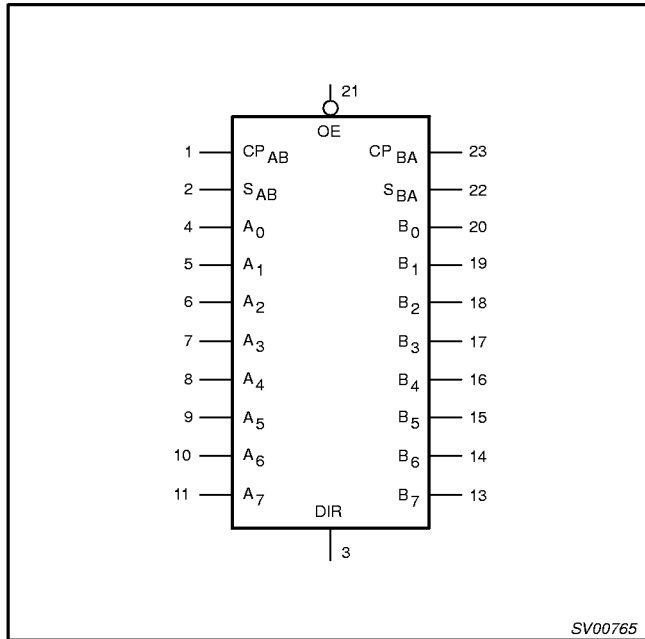

LOGIC SYMBOL (IEEE/IEC)

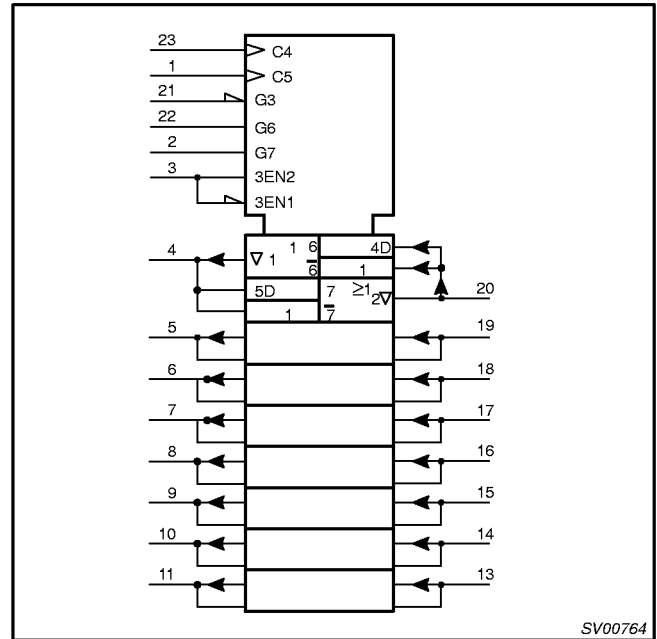

FUNCTIONAL DIAGRAM

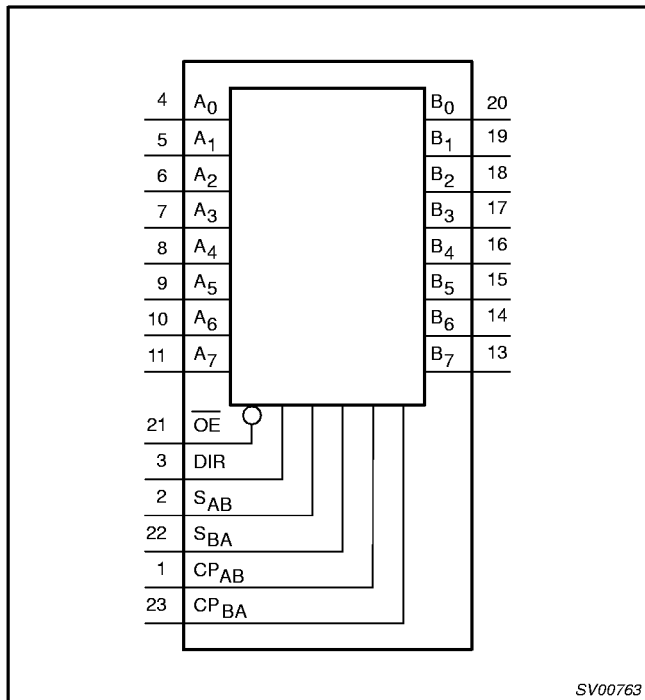

Octal bus transceiver/register (3-State)

74AC646
74ACT646

LOGIC DIAGRAM

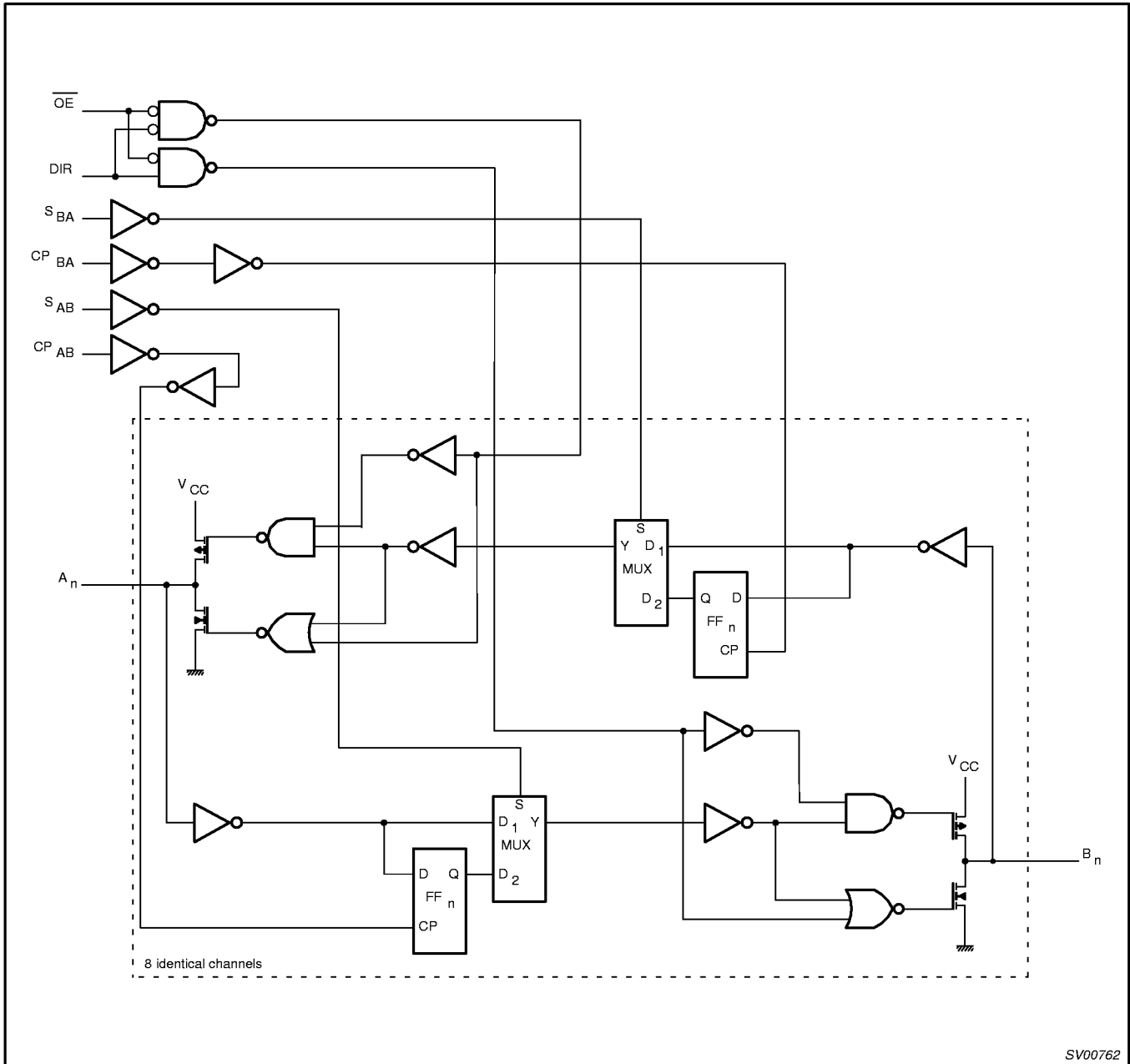

SV00762

Octal bus transceiver/register (3-State)

74AC646
74ACT646

RECOMMENDED OPERATING CONDITIONS

SYMBOL	PARAMETER	LIMITS		UNIT
		MIN	MAX	
V _{CC}	DC supply voltage for 'AC	2.0	6.0	V
V _{CC}	DC supply voltage for 'ACT	4.5	5.5	V
V _I	DC input voltage range	0	V _{CC}	V
V _O	DC output voltage range	0	V _{CC}	V
T _{amb}	Operating free-air temperature range	-40	+85	°C
ΔV/Δt	Minimum input edge rate — AC devices V _{IN} from 30% to 70% of V _{CC} V _{CC} @ 3.3V, 4.5V, 5.5V	125		mV/ns
	— ACT devices V _{IN} from 0.8V to 2.0V V _{CC} @ 4.5V, 5.5V	125		

ABSOLUTE MAXIMUM RATINGS¹

in accordance with the Absolute Maximum Rating System (IEC134)

Voltages are referenced to GND (ground = 0V)

SYMBOL	PARAMETER	CONDITIONS	RATING	UNIT
V _{CC}	DC supply voltage		-0.5 to +7.0	V
I _{IK}	DC input diode current	V _I = -0.5V	-20	mA
		V _I = V _{CC} + 0.5V	+20	
V _I	DC input voltage		-0.5 to V _{CC} + 0.5	V
I _{OK}	DC output diode current	V _O = -0.5V	-20	mA
		V _O = V _{CC} + 0.5V	+20	
V _O	DC output voltage		-0.5 to V _{CC} + 0.5	V
I _O	DC output source or sink current		± 50	mA
I _{CC} , I _{GND}	DC V _{CC} or GND current per output		± 50	mA
I _{CC} , I _{GND}	DC V _{CC} or GND current		± 200	mA
T _{stg}	Storage temperature range		-65 to 150	°C
P _{TOT}	Power dissipation per package — plastic mini-pack (SO) — plastic shrink mini-pack (SSOP and TSSOP)	above +70°C derate linearly with 8 mW/K	500	mW
		above +60°C derate linearly with 5.5 mW/K	500	

NOTES:

- Stresses beyond those listed may cause permanent damage to the device. These are stress ratings only and functional operation of the device at these or any other conditions beyond those indicated under "recommended operating conditions" is not implied. Exposure to absolute-maximum-rated conditions for extended periods may affect device reliability.

Octal bus transceiver/register (3-State)

74AC646
74ACT646

DC ELECTRICAL CHARACTERISTICS FOR AC FAMILY

Over recommended operating conditions voltages are referenced to GND (ground = 0V)

SYMBOL	PARAMETER	TEST CONDITIONS	V _{CC} (V)	LIMITS			UNIT
				Temp = -40°C to +85°C			
				MIN	TYP ¹	MAX	
V _{IH}	HIGH level Input voltage	V _{OUT} = 0.1V or (V _{CC} - 0.1V)	3.0	2.1	1.5		V
			4.5	3.15	2.25		
			5.5	3.85	2.75		
V _{IL}	LOW level Input voltage	V _{OUT} = 0.1V or (V _{CC} - 0.1V)	3.0		1.5	0.9	V
			4.5		2.25	1.35	
			5.5		2.75	1.65	
V _{OH}	HIGH level output voltage	I _{OUT} = -50 μA	3.0	2.9	2.99		V
			4.5	4.4	4.49		
			5.5	5.4	5.49		
		V _{IN} = V _{IL} or V _{IH} ; I _{OH} = -12mA ¹	3.0	2.46			V
		V _{IN} = V _{IL} or V _{IH} ; I _{OH} = -24mA ¹	4.5	3.76			
V _{IN} = V _{IL} or V _{IH} ; I _{OH} = -24mA ¹	5.5	4.76					
V _{OL}	LOW level output voltage	I _{OUT} = 50 μA	3.0		0.01	0.1	V
			4.5		0.01	0.1	
			5.5		0.01	0.1	
		V _{IN} = V _{IL} or V _{IH} ; I _{OL} = 12mA ¹	3.0			0.44	V
		V _{IN} = V _{IL} or V _{IH} ; I _{OL} = 24mA ¹	4.5			0.44	
V _{IN} = V _{IL} or V _{IH} ; I _{OL} = 24mA ¹	5.5			0.44			
I _{IN}	Input leakage current	V _{IN} = V _{CC} ; GND	5.5			±1.0	μA
I _{OZ}	3-State output OFF-state current	V _{IN} = V _{IL} ; V _{IH} V _{OUT} = V _{CC} ; GND	5.5			±2.5	μA
I _{OLD}	Dynamic output current ²	V _{OLD} = 1.65V max	5.5	75			mA
I _{OHD}	Dynamic output current ²	V _{OHD} = 3.85V min	5.5			-75	mA
I _{CC}	Quiescent supply current	V _{IN} = V _{CC} or GND	5.5			40	μA

NOTES:

1. All outputs loaded
2. Maximum test duration 2.0 ms; one output loaded at a time

Octal bus transceiver/register (3-State)

74AC646
74ACT646

DC ELECTRICAL CHARACTERISTICS FOR ACT FAMILY

Over recommended operating conditions voltages are referenced to GND (ground = 0V)

SYMBOL	PARAMETER	TEST CONDITIONS	V _{CC} (V)	LIMITS			UNIT
				Temp = -40°C to +85°C			
				MIN	TYP ¹	MAX	
V _{IH}	HIGH level Input voltage	V _{OUT} = 0.1V or (V _{CC} - 0.1V)	4.5	2.0	1.5		V
			5.5	2.0	1.5		
V _{IL}	LOW level Input voltage	V _{OUT} = 0.1V or (V _{CC} - 0.1V)	4.5		1.5	0.8	V
			5.5		1.5	0.8	
V _{OH}	HIGH level output voltage	I _{OUT} = -50 μA	4.5	4.4	4.49		V
			5.5	5.4	5.49		
		V _{IN} = V _{IL} or V _{IH} ; I _{OH} = -24mA ¹	4.5	3.76			V
		V _{IN} = V _{IL} or V _{IH} ; I _{OH} = -24mA ¹	5.5	4.76			
V _{OL}	LOW level output voltage	I _{OUT} = 50 μA	4.5		0.01	0.1	V
			5.5		0.01	0.1	
		V _{IN} = V _{IL} or V _{IH} ; I _{OL} = 24mA ¹	4.5			0.44	V
		V _{IN} = V _{IL} or V _{IH} ; I _{OL} = 24mA ¹	5.5			0.44	
I _{IN}	Input leakage current	V _{IN} = V _{CC} , GND	5.5			±1.0	μA
I _{OZ}	3-State output OFF-state current	V _{IN} = V _{IL} , V _{IH} V _{OUT} = V _{CC} , GND	5.5			±2.5	μA
ΔI _{CC}	Additional quiescent supply current per input pin	V _{IN} = V _{CC} - 2.1V Other inputs at V _{CC} or GND; I _{OUT} = 0	5.5			1.5	mA
I _{OLD}	Dynamic output current ²	V _{OLD} = 1.65V max	5.5	75			mA
I _{OHD}	Dynamic output current ²	V _{OHD} = 3.85V min	5.5			-75	mA
I _{CC}	Quiescent supply current	V _{IN} = V _{CC} or GND	5.5			40	μA

NOTES:

1. All outputs loaded
2. Maximum test duration 2.0ms, one output loaded at a time

Octal bus transceiver/register (3-State)

74AC646
74ACT646

AC CHARACTERISTICS FOR (74AC646)

GND = 0V; $t_R = t_F = 2.5\text{ns}$; $C_L = 50\text{pF}$; $R_L = 500\Omega$; .

SYMBOL	PARAMETER	V _{CC} ¹	LIMITS					UNIT	WAVEFORM
			T _{amb} = +25°C			T _{amb} = -40°C to +85°C			
			MIN	TYP	MAX	MIN	MAX		
t _{PLH}	Propagation delay A _n , B _n to B _n , A _n	3.3 5.0	2.0 1.5	5.0 3.4	12 8	1.5 1.0	13.5 9	ns	1
t _{PHL}	Propagation delay A _n , B _n to B _n , A _n	3.3 5.0	2.0 1.5	5.2 3.7	12 8	1.5 1.0	13.5 9	ns	1
t _{PLH}	Propagation delay CP _{AB} , CP _{BA} to B _n , A _n	3.3 5.0	2.0 1.5	5.9 4.0	14 9.5	1.5 1.0	16 11	ns	2
t _{PHL}	Propagation delay CP _{AB} , CP _{BA} to B _n , A _n	3.3 5.0	2.0 1.5	6.1 4.3	14 9.5	1.5 1.0	16 11	ns	2
t _{PLH}	Propagation delay S _{AB} , S _{BA} to B _n , A _n	3.3 5.0	2.0 1.5	6.2 4.2	13 9	1.5 1.0	15 10	ns	3
t _{PHL}	Propagation delay S _{AB} , S _{BA} to B _n , A _n	3.3 5.0	2.0 1.5	6.8 4.9	13 9	1.5 1.0	15 10	ns	3
t _{PZH}	3-State output enable time \overline{OE} to B _n , A _n	3.3 5.0	2.0 1.5	5.6 3.9	11 7.5	1.5 1.0	12.5 8.5	ns	4
t _{PZL}	3-State output enable time \overline{OE} to B _n , A _n	3.3 5.0	2.0 1.5	6.5 4.5	11 7.5	1.5 1.0	12.5 8.5	ns	4
t _{PHZ}	3-State output disable time \overline{OE} to B _n , A _n	3.3 5.0	2.0 1.5	4.9 3.2	11 7.5	1.5 1.0	12 8.5	ns	4
t _{PLZ}	3-State output disable time \overline{OE} to B _n , A _n	3.3 5.0	2.0 1.5	4.5 3.2	11 7.5	1.5 1.0	12 8.5	ns	4
t _{PZH}	3-State output enable time DIR to B _n , A _n	3.3 5.0	2.0 1.5	5.5 3.8	10.5 7	1.5 1.0	12 8	ns	5
t _{PZL}	3-State output enable time DIR to B _n , A _n	3.3 5.0	2.0 1.5	6.4 4.5	10.5 7	1.5 1.0	12 8	ns	5
t _{PHZ}	3-State output disable time DIR to B _n , A _n	3.3 5.0	2.0 1.5	5.1 2.9	10.5 7	1.5 1.0	11.5 8	ns	5
t _{PLZ}	3-State output disable time DIR to B _n , A _n	3.3 5.0	2.0 1.5	4.6 2.7	10.5 7	1.5 1.0	11.5 8	ns	5
t _w	Clock pulse width HIGH or LOW CP _{AB} or CP _{BA}	3.3 5.0	4 3	2 1		4.5 3.5		ns	2
t _{su}	Set up time A _n , B _n to CP _{AB} , CP _{BA}	3.3 5.0	3.5 3.0	0.5 0.3		4 3.5		ns	2
t _h	Hold time A _n , B _n to CP _{AB} , CP _{BA}	3.3 5.0	0.5 1.0	-0.2 -0.1		1.0 1.5		ns	2
f _{max}	Maximum clock pulse frequency	3.3 5.0	75 110	120 180		60 100		MHz	2

NOTE:

1. Voltage range 3.3V is V_{CC} = 3.3V ± 0.3V
Voltage range 5.0V is V_{CC} = 5.0V ± 0.5V

Octal bus transceiver/register (3-State)

74AC646
74ACT646

AC CHARACTERISTICS FOR (74ACT646)

GND = 0V; $t_R = t_F = 2.5\text{ns}$; $C_L = 50\text{pF}$; $R_L = 500\Omega$; .

SYMBOL	PARAMETER	V _{CC} ¹	LIMITS					UNIT	WAVEFORM
			T _{amb} = +25°C			T _{amb} = -40°C to +85°C			
			MIN	TYP	MAX	MIN	MAX		
t _{PLH}	Propagation delay A _n , B _n to B _n , A _n	5.0	2.0	6.1	10	1.5	11.5	ns	1
t _{PHL}	Propagation delay A _n , B _n to B _n , A _n	5.0	2.0	5.5	10	1.5	11.5	ns	1
t _{PLH}	Propagation delay CP _{AB} , CP _{BA} to B _n , A _n	5.0	2.0	5.9	14	1.5	16	ns	2
t _{PHL}	Propagation delay CP _{AB} , CP _{BA} to B _n , A _n	5.0	2.0	5.9	14	1.5	16	ns	2
t _{PLH}	Propagation delay S _{AB} , S _{BA} to B _n , A _n	5.0	2.0	6.4	11	1.5	12.5	ns	3
t _{PHL}	Propagation delay S _{AB} , S _{BA} to B _n , A _n	5.0	2.0	6.9	11	1.5	12.5	ns	3
t _{PZH}	3-State output enable time OE to B _n , A _n	5.0	2.0	4.9	10.5	1.5	12	ns	4
t _{PZL}	3-State output enable time OE to B _n , A _n	5.0	2.0	6	10.5	1.5	12	ns	4
t _{PHZ}	3-State output disable time OE to B _n , A _n	5.0	2.0	4.6	10.5	1.5	11.5	ns	4
t _{PLZ}	3-State output disable time OE to B _n , A _n	5.0	2.0	4.5	10.5	1.5	11.5	ns	4
t _{PZH}	3-State output enable time DIR to B _n , A _n	5.0	2.0	4.9	10	1.5	11.5	ns	5
t _{PZL}	3-State output enable time DIR to B _n , A _n	5.0	2.0	5.8	10	1.5	11.5	ns	5
t _{PHZ}	3-State output disable time DIR to B _n , A _n	5.0	2.0	3.8	10	1.5	11	ns	5
t _{PLZ}	3-State output disable time DIR to B _n , A _n	5.0	2.0	3.9	10	1.5	11	ns	5
t _w	Clock pulse width HIGH or LOW CP _{AB} or CP _{BA}	5.0	5.0	3		5.5		ns	2
t _{su}	Set up time A _n , B _n to CP _{AB} , CP _{BA}	5.0	5.0	1.4		5.5		ns	2
t _h	Hold time A _n , B _n to CP _{AB} , CP _{BA}	5.0	0.5	-1.3		1.0		ns	2
f _{max}	Maximum clock pulse frequency	5.0	110	180		100		MHz	2

NOTE:

1. These values are at V_{CC} = 5.0V ± 0.5V

Octal bus transceiver/register (3-State)

74AC646
74ACT646

AC WAVEFORMS

V_{OL} and V_{OH} are the typical output voltage drops that occur with the output load.

$$V_X = V_{OL} + 0.3V$$

$$V_Y = V_{OH} - 0.3V$$

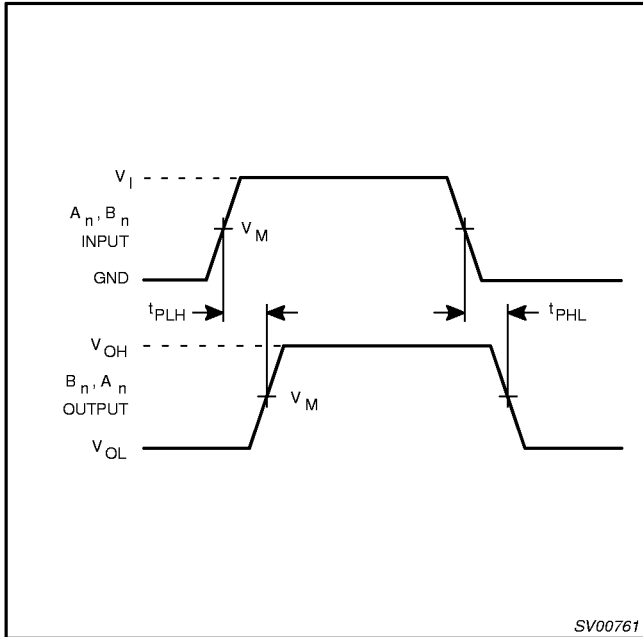

Waveform 1. Input A_n, B_n to output B_n, A_n propagation delays.

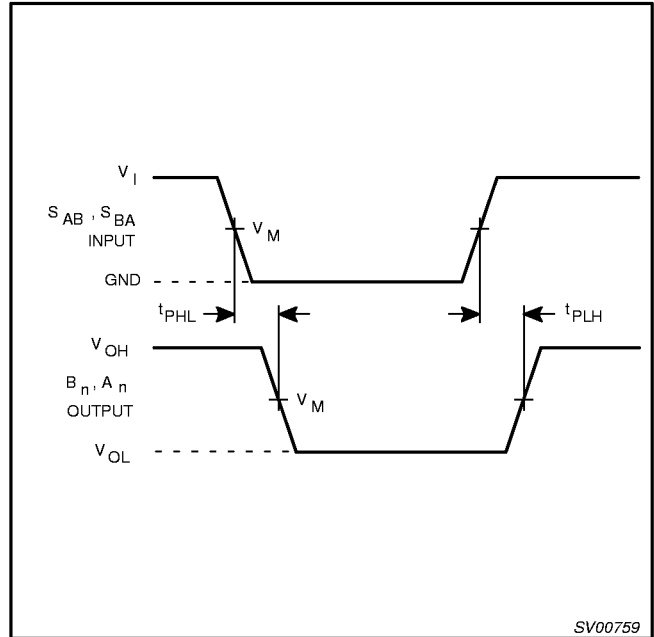

Waveform 3. Input S_{AB}, S_{BA} to output B_n, A_n propagation delay times.

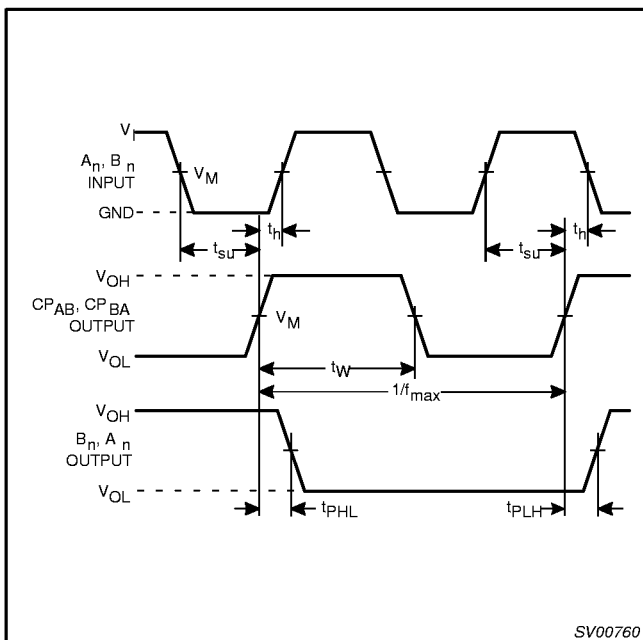

Waveform 2. A_n, B_n to CP_{AB}, CP_{BA} set-up and hold times, clock CP_{AB}, CP_{BA} pulse width, maximum clock pulse frequency and the CP_{AB}, CP_{BA} to output B_n, A_n propagation delays.

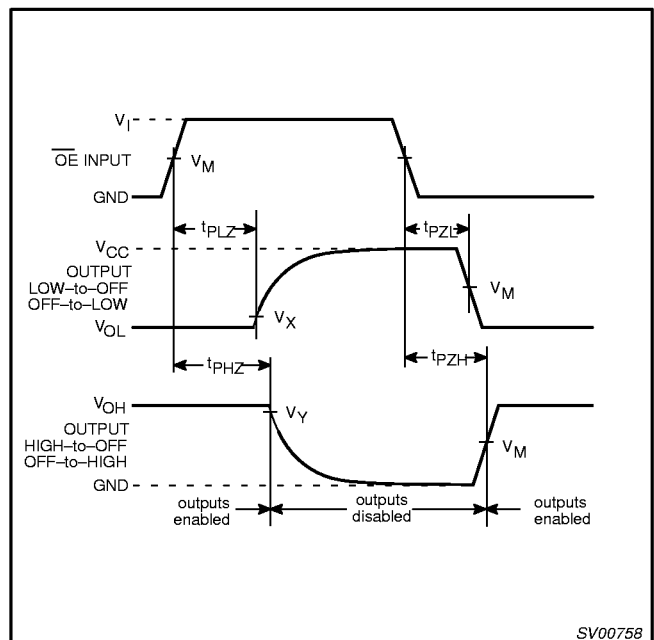

Waveform 4. Input \overline{OE} to output A_n, B_n 3-State enable and disable times.

Octal bus transceiver/register (3-State)

74AC646
74ACT646

AC WAVEFORMS (Continued)

V_{OL} and V_{OH} are the typical output voltage drops that occur with the output load.

$V_X = V_{OL} + 0.3V$

$V_Y = V_{OH} - 0.3V$

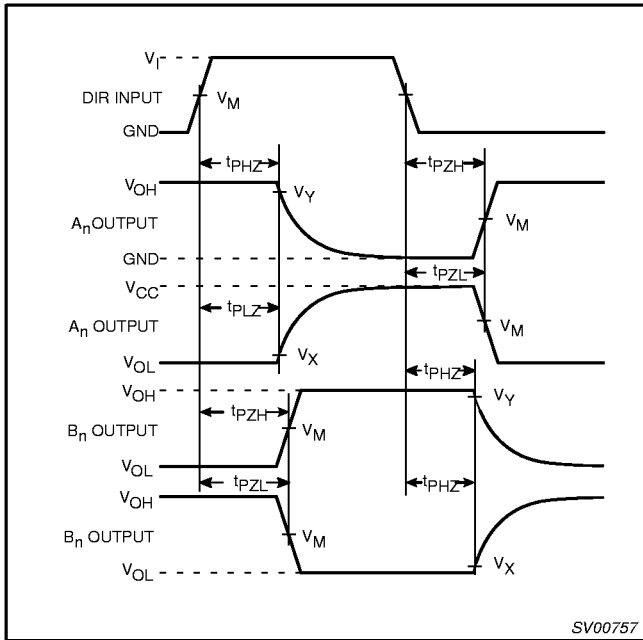

Waveform 5. Input DIR to output A_n, B_n 3-State enable and disable times.

TEST CIRCUIT

Test Circuit for 3-State Outputs

The test circuit consists of a PULSE GENERATOR connected to the input V_{IN} of a D.U.T. (Device Under Test). The output V_{OUT} is connected to a load circuitry consisting of a load resistor R_L and a load capacitor C_L. A switch is used to connect the load resistor R_L to either 2 x V_{CC} or GND. A termination resistor R_T is connected to the input V_{IN}.

SWITCH POSITION		FAMILY	V _{IN} Input Requirements	V _m Input	V _m Output
TEST	SWITCH				
t _{PLH} /t _{PHL}	Open	AC	GND to V _{CC}	50% V _{CC}	50% V _{CC}
t _{PLZ} /t _{PZL}	2 x V _{CC}				
t _{PHZ} /t _{PZH}	Open	ACT	GND to 3.0V	1.5V	50% V _{CC}

DEFINITIONS

R_L = Load resistor; see AC characteristics for value.

C_L = Load capacitance, see AC characteristics

R_T = Termination resistance should be equal to Z_{OUT} of pulse generators.

Waveform 6. Load circuitry for switching times.

Octal bus transceiver/register (3-State)

74AC646
74ACT646

SO24: plastic small outline package; 24 leads; body width 7.5 mm

SOT137-1

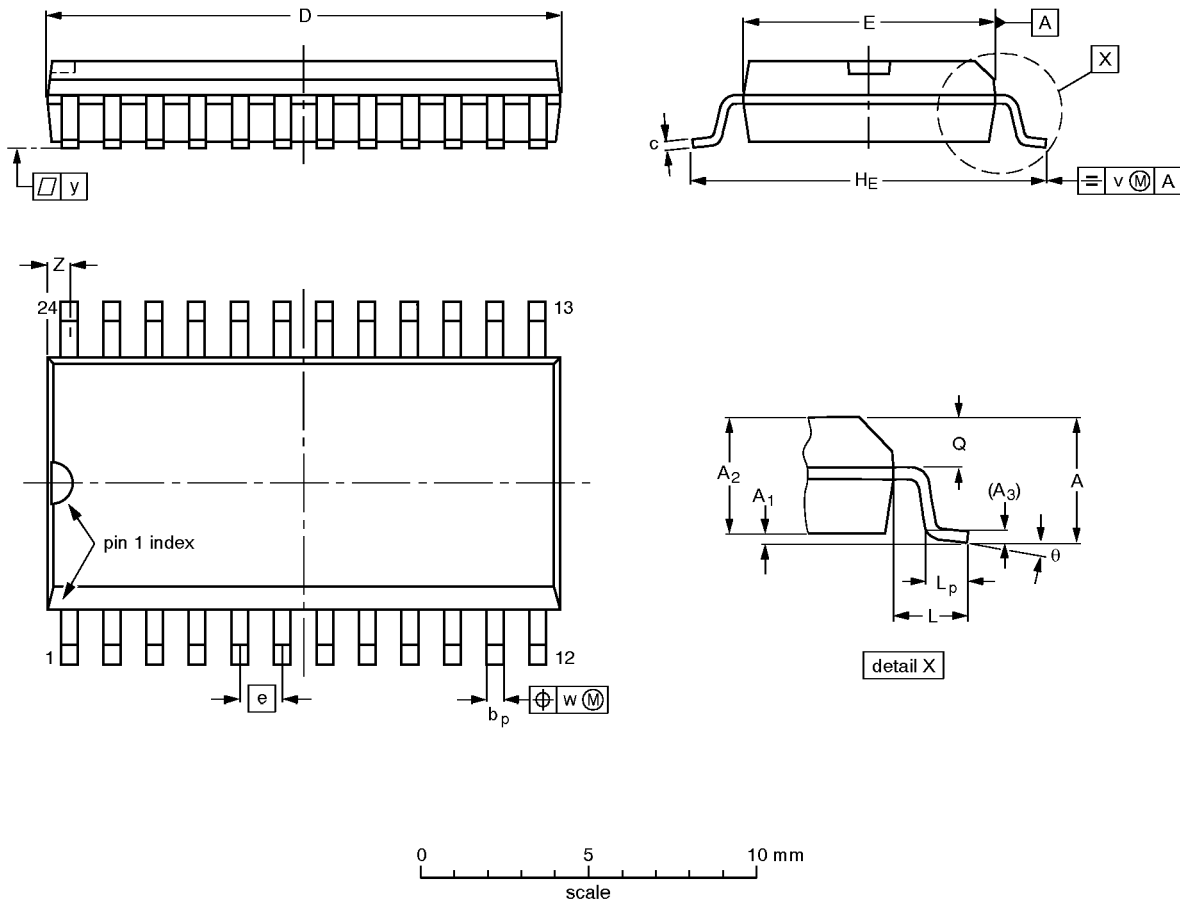

DIMENSIONS (inch dimensions are derived from the original mm dimensions)

UNIT	A max.	A ₁	A ₂	A ₃	b _p	c	D ⁽¹⁾	E ⁽¹⁾	e	H _E	L	L _p	Q	v	w	y	Z ⁽¹⁾	θ
mm	2.65	0.30 0.10	2.45 2.25	0.25	0.49 0.36	0.32 0.23	15.6 15.2	7.6 7.4	1.27	10.65 10.00	1.4	1.1 0.4	1.1 1.0	0.25	0.25	0.1	0.9 0.4	8° 0°
inches	0.10	0.012 0.004	0.096 0.089	0.01	0.019 0.014	0.013 0.009	0.61 0.60	0.30 0.29	0.050	0.42 0.39	0.055	0.043 0.016	0.043 0.039	0.01	0.01	0.004	0.035 0.016	

Note

1. Plastic or metal protrusions of 0.15 mm maximum per side are not included.

OUTLINE VERSION	REFERENCES				EUROPEAN PROJECTION	ISSUE DATE
	IEC	JEDEC	EIAJ			
SOT137-1	075E05	MS-013AD				-92-11-17 95-01-24

Octal bus transceiver/register (3-State)

74AC646
74ACT646

SSOP24: plastic shrink small outline package; 24 leads; body width 5.3 mm

SOT340-1

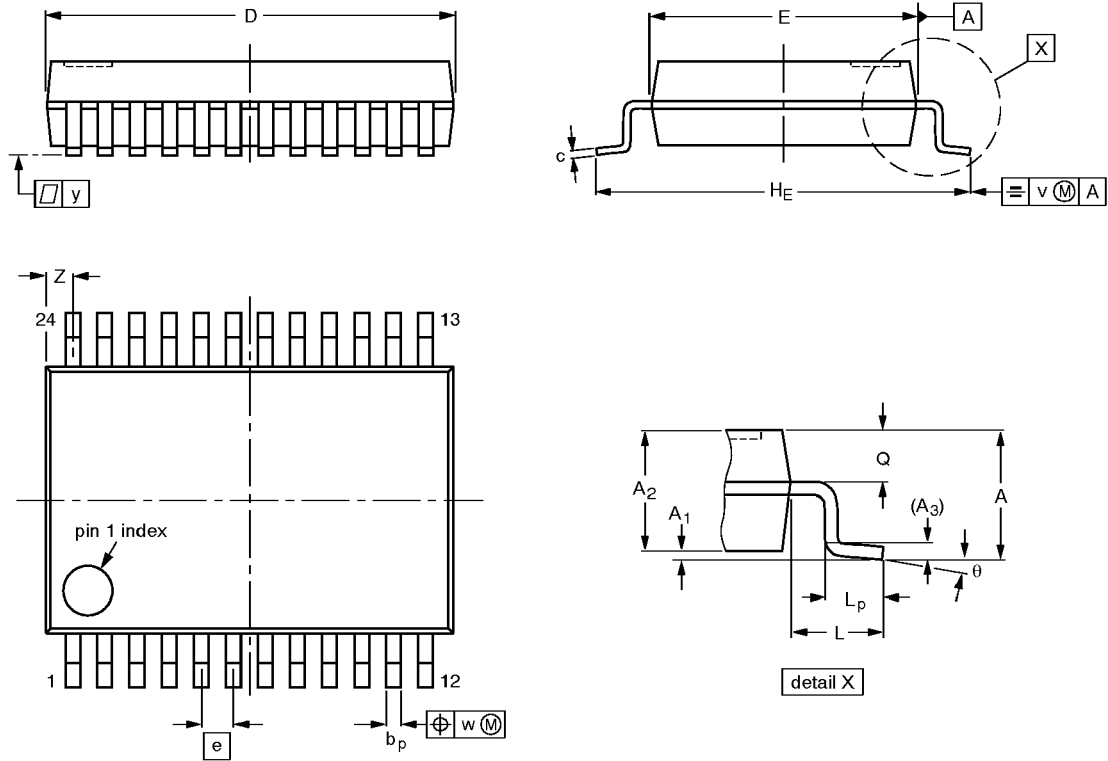

DIMENSIONS (mm are the original dimensions)

UNIT	A max.	A ₁	A ₂	A ₃	b _p	c	D ⁽¹⁾	E ⁽¹⁾	e	H _E	L	L _p	Q	v	w	y	Z ⁽¹⁾	θ
mm	2.0	0.21 0.05	1.80 1.65	0.25	0.38 0.25	0.20 0.09	8.4 8.0	5.4 5.2	0.65	7.9 7.6	1.25	1.03 0.63	0.9 0.7	0.2	0.13	0.1	0.8 0.4	8° 0°

Note

1. Plastic or metal protrusions of 0.20 mm maximum per side are not included.

OUTLINE VERSION	REFERENCES			EUROPEAN PROJECTION	ISSUE DATE
	IEC	JEDEC	EIAJ		
SOT340-1		MO-150AG			93-09-08 95-02-04

Octal bus transceiver/register (3-State)

74AC646
74ACT646

TSSOP24: plastic thin shrink small outline package; 24 leads; body width 4.4 mm

SOT355-1

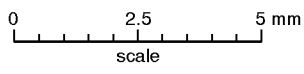
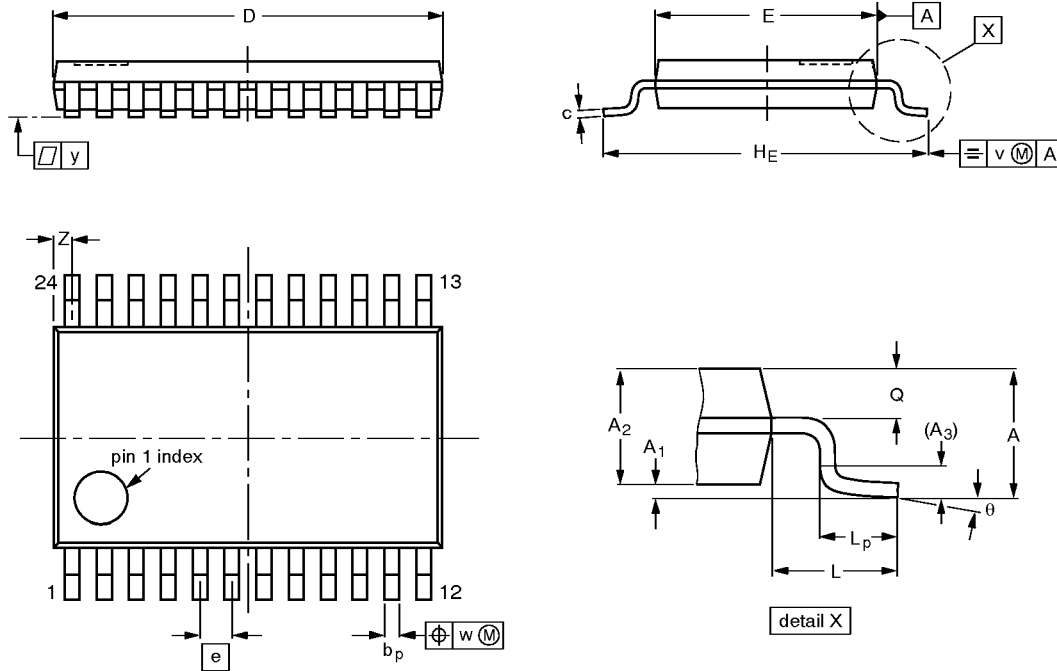

DIMENSIONS (mm are the original dimensions)

UNIT	A max.	A ₁	A ₂	A ₃	b _p	c	D ⁽¹⁾	E ⁽²⁾	e	H _E	L	L _p	Q	v	w	y	Z ⁽¹⁾	θ
mm	1.10	0.15 0.05	0.95 0.80	0.25	0.30 0.19	0.2 0.1	7.9 7.7	4.5 4.3	0.65	6.6 6.2	1.0	0.75 0.50	0.4 0.3	0.2	0.13	0.1	0.5 0.2	8° 0°

Notes

1. Plastic or metal protrusions of 0.15 mm maximum per side are not included.
2. Plastic interlead protrusions of 0.25 mm maximum per side are not included.

OUTLINE VERSION	REFERENCES				EUROPEAN PROJECTION	ISSUE DATE
	IEC	JEDEC	EIAJ			
SOT355-1		MO-153AD				93-06-16 95-02-04