

HD74HCT651 ● Octal Bus Transceivers and Registers (with inverted 3-state outputs)

HD74HCT652 ● Octal Bus Transceivers and Registers (with 3-state outputs)

This device consists of bus transceiver circuits, D-type flip-flops, and control circuitry arranged for multiplexed transmission of data directly from the data bus or from the internal storage registers. Enable GAB and \overline{GBA} are provide to control the transceiver functions. Select AB and Select BA control pins are provided to select whether real-time or stored data is transferred. A low input level selects real-time data, and a high selects stored data. The following examples demonstrate the four fundamental busmanagement functions that can be performed with the HD74HCT651 and HD74HCT652.

Data on the A or B data bus, or both, can be stored in the internal D flip-flops by low-to-high transitions at the appropriate clock pins Clock AB or Clock BA regardless of the select or enable control pins. When Select AB and Select BA are in the real-time transfer mode, it is also possible to store data without using the internal D-type flip-flops by simultaneously enabling Enable GAB and \overline{GBA} . In this configuration each output reinforces its input. Thus, when all other data sources to the two sets of bus lines are at high impedance, each set of bus lines will remain at its last state.

■ PIN ARRANGEMENT

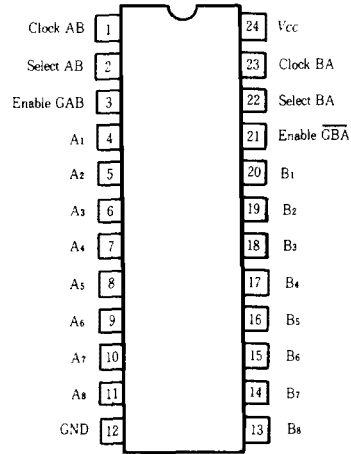

(Top View)

■ FEATURES

- LSTTL Output Logic Level Compatibility as well as CMOS Output Compatibility
- High Speed Operation
- High Output Current: Fanout of 15 LSTTL Loads
- Wide Operating Voltage: $V_{CC}=4.5\sim 5.5V$
- Low Input Current: $1\mu A$ max.
- Low Quiescent Supply Current: I_{CC} (static)= $4\mu A$ max. ($T_a=25^\circ C$)

■ FUNCTION TABLE

	Real-Time Transfer Bus B to Bus A	Real-Time Transfer Bus A to Bus B	Storage	Transfer Stored Data to A and/or B
Clock AB	x	x		L or H
Select AB	x	L	x	H
Enable GAB	L	H	L	H
Clock BA	x	x		L or H
Select BA	L	x	x	H
Enable GBA	L	H	H	L

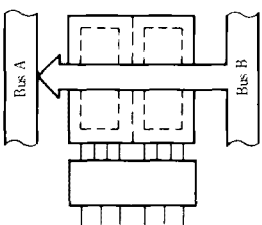

Real-Time Transfer Bus B to Bus A

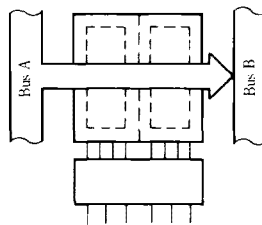

Real-Time Transfer Bus A to Bus B

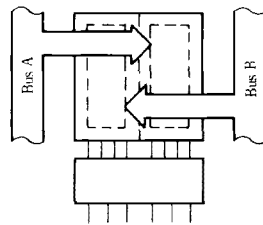

Storage

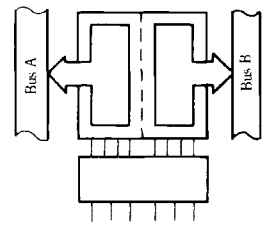

Transfer Stored Data to A and/or B

NOTE
The specifications of this device are subject to change without notice.
Please contact your nearest Hitachi's Sales Dept. regarding specifications.

LOGIC DIAGRAM

● HD74HCT651

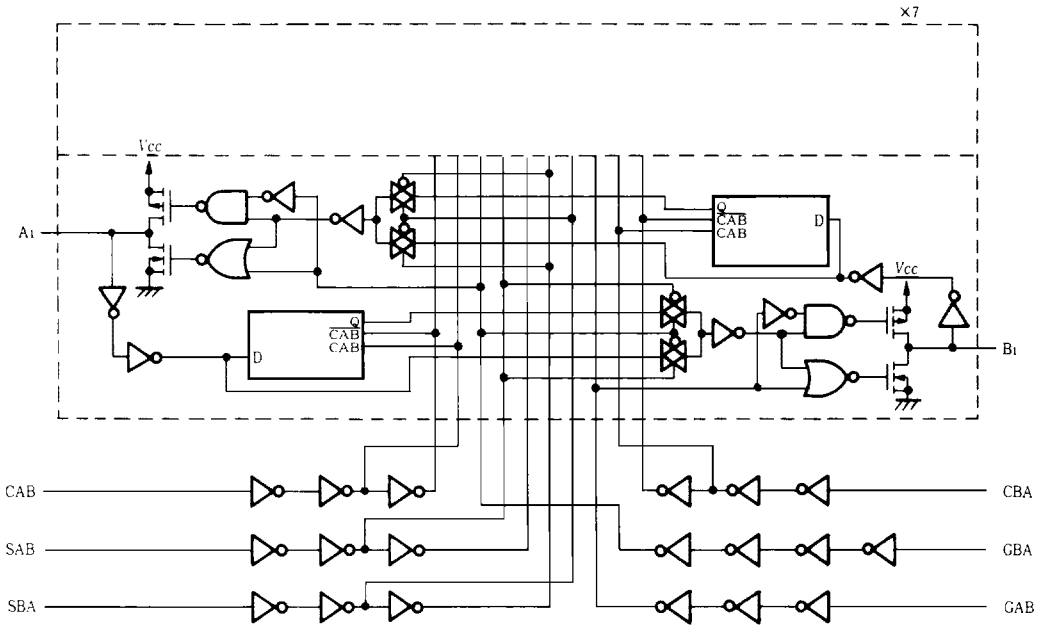

● HD74HCT652

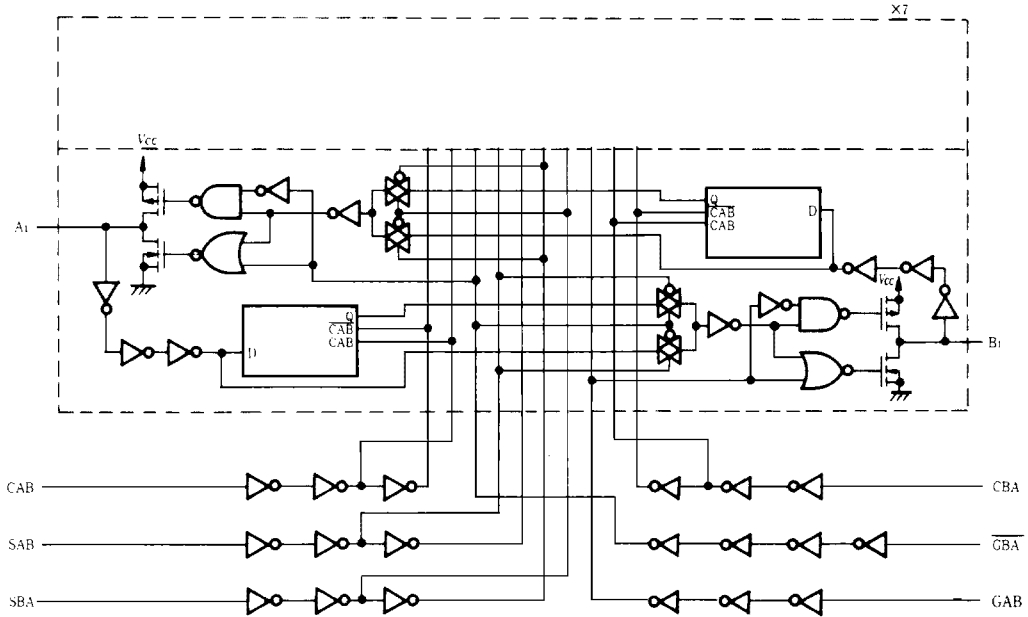

■ ABSOLUTE MAXIMUM RATINGS

Item	Symbol	Rating	Unit
Supply Voltage Range	V_{CC}	-0.5~+7.0	V
Input Voltage	V_{IN}	-0.5~ $V_{CC}+0.5$	V
Output Voltage	V_{OUT}	-0.5~ $V_{CC}+0.5$	V
DC Current Drain per pin	I_{OUT}	±35	mA
DC Current Drain per Vcc,GND	I_{CC}, I_{GND}	±75	mA
DC Input Diode Current	I_{IK}	±20	mA
DC Output Diode Current	I_{OK}	±20	mA
Power Dissipation per Package	P_T	500	mW
Storage Temperature	T_{stg}	-65~+150	°C

■ DC CHARACTERISTICS

Item	Symbol	$V_{CC}(V)$	Test Conditions	$T_a=25^{\circ}C$			$T_a=-40\sim+85^{\circ}C$		Unit	
				min	typ	max	min	max		
Input Voltage	V_{IH}	4.5~5.5		2.0	—	—	2.0	—	V	
	V_{IL}	4.5~5.5		—	—	0.8	—	0.8	V	
Output Voltage	V_{OH}	4.5	$V_{in}=V_{IH}$ or V_{IL}	$I_{OH}=-20\mu A$	4.4	—	—	4.4	—	V
		4.5		$I_{OH}=-6mA$	4.18	—	—	4.13	—	V
	V_{OL}	4.5	$V_{in}=V_{IH}$ or V_{IL}	$I_{OL}=20\mu A$	—	—	0.1	—	0.1	V
		4.5		$I_{OL}=6mA$	—	—	0.26	—	0.33	V
Off-state output current	I_{OZ}	5.5	$V_{in}=V_{IH}$ or $V_{IL}, V_{out}=V_{CC}$ or GND	—	—	±0.5	—	±5.0	μA	
Input Current	I_{in}	5.5	$V_{in}=V_{CC}$ or GND	—	—	±0.1	—	±1.0	μA	
Quiescent Current	I_{CC}	5.5	$V_{in}=V_{CC}$ or GND, $I_{out}=0\mu A$	—	—	4.0	—	40	μA	

■ AC CHARACTERISTICS ($C_L=50pF$, Input $t_r=t_f=6ns$)

Item	Symbol	$V_{CC}(V)$	Test Conditions	$T_a=25^{\circ}C$			$T_a=-40\sim+85^{\circ}C$		Unit
				min.	typ.	max.	min.	max.	
Propagation Delay Time	t_{PLH}	4.5	Clock to Bus	—	—	35	—	44	ns
	t_{PHL}	4.5		—	—	35	—	44	
	t_{PLH}	4.5	Bus to Bus	—	—	27	—	34	ns
	t_{PHL}	4.5		—	—	27	—	34	
	t_{PLH}	4.5	Select to Bus	—	—	38	—	48	ns
	t_{PHL}	4.5		—	—	38	—	48	
Output Enable Time	t_{ZH}	4.5		—	—	30	—	38	ns
	t_{ZL}	4.5		—	—	30	—	38	
Output Disable Time	t_{HZ}	4.5		—	—	30	—	38	ns
	t_{LZ}	4.5		—	—	30	—	38	
Pulse Width	t_w	4.5		16	—	—	20	—	ns
Setup Time	t_{su}	4.5		10	—	—	13	—	ns
Hold Time	t_h	4.5		15	—	—	19	—	ns
Output Rise/Fall Time	t_{rHL} t_{fHL}	4.5		—	—	12	—	15	ns
Input Capacitance	C_{in}	—		—	5	10	—	10	pF