

General-purpose CMOS Logic IC Series (BU4000B Series)

# High Voltage CMOS Logic ICs

## <Function Logic>



**BU4015B/F, BU4021B/F, BU4094BC/F/FV, BU4538B, BU4028B**

### ●Description

BU4015B series ICs are 4-stage static shift registers, each consisting of 2 circuits. The D flip-flops of each stage share a common reset input, enabling asynchronous reset at any time.

BU4021B series ICs are 8-bit static shift registers configured with 8 register cells, each of which has parallel input. Control of the parallel/serial input (P/S) enables serial input/output with clock synchronization and well as parallel input/serial output conversions.

BU4094BC series ICs are shift/store registers, each consisting of an 8-bit shift register and an 8-bit latch. Output can be held in the data transfer mode because the data read into the shift register can be latched by the asynchronous strobe input,

The BU4538B IC is a monostable multivibrator that can be reset and retriggered from either edge of an input pulse. A wide range of accurate output pulse widths is available because the output pulse width and accuracy are determined by the external timing constants Cx and Rx.

The BU4028B IC is a decoder which converts BCD signals into decimal signals. Of the 10 outputs (Q0 ~ Q9), those corresponding to the input codes A-D are set to "H", while the others are set to "L".

### ●Features

- 1) Low power consumption
- 2) Wide operating supply voltage range
- 3) High impedance
- 4) High fan out
- 5) L-TTL2 and LS-TTL1 inputs can be driven directly.

### ●Applications

BU4015B: serial / parallel data conversion and ring counter.

BU4021B: control circuits, timing circuits and as a general purpose register requiring high degree of noise tolerance.

BU4094BC: series/parallel data conversion and data receivers.

BU4538B: can obtain the output pulse amplitude with improved accuracy by external capacity and resistance.

BU4028B: code conversion, address decoding, memory selection control, demultiplexing or readout and decoding, etc.

### ●Lineup

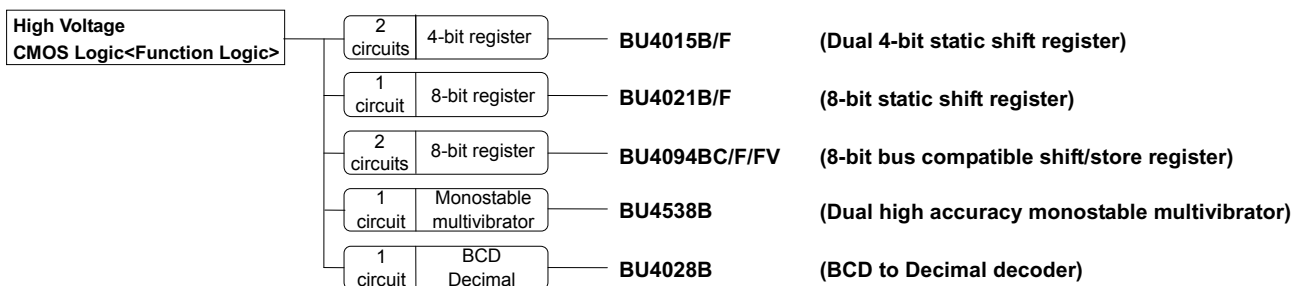

● Absolute Maximum Ratings

Parameter	Symbol	Limit					Unit
		BU4015B	BU4021B	BU4094BC	BU4538B	BU4028B	
Power Supply Voltage	VDD	-0.3 to 18					V
Supply Current	Iin	±10					mA
Operating Temperature	Topr	-40 to 85					°C
Storage Temperature	Tstg	-55 to 150					°C
Input Voltage	VIN	-0.3 to VDD+0.3					V
Maximum Junction Temperature	Tjmax	150					°C

● Recommended Operating Conditions

Parameter	Symbol	Limit					Unit
		BU4015B	BU4021B	BU4094BC	BU4538B	BU4028B	
Operating Power Supply	VDD	3 to 16 (3 to 18V @BU4094BC)					V
Input Voltage	VIN	0 to VDD					V

● Thermal Derating Curve

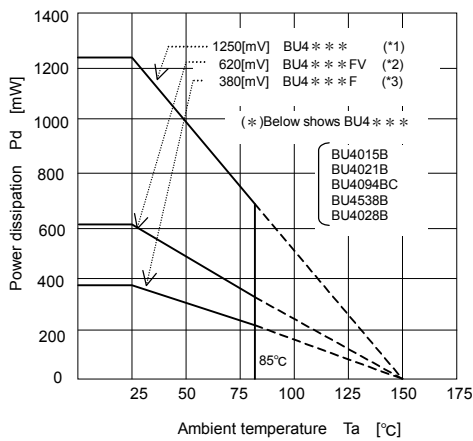

(* 1)	(* 2)	(* 3)	Unit
10.0	5.0	3.1	mW/°C

When used at Ta=25°C or higher the value above is reduced per 1°C. Power Dissipation is measured by using the sample mounted on a 70mm × 70mm × 1.6mm FR4 glass-epoxy PCB (copper area is less than 3%)

● Input / Output Equivalent Circuits

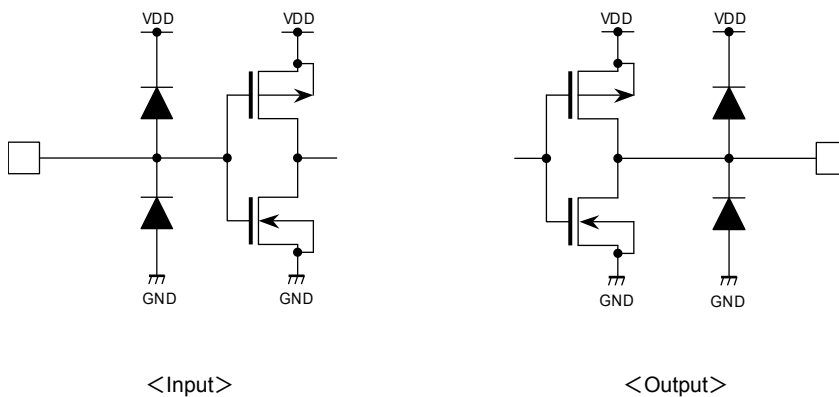

●Electrical Characteristics (BU4015B)

DC Characteristics (Unless otherwise noted VSS=0[V], Ta=25[°C])

Parameter	Symbol	Limits			Unit	VDD[V]	Condition	Fig. No
		Min	Typ	Max				
Input 'H' voltage	VIH	3.5	—	—	V	5	—	—
		7.0	—	—		10		
		11.0	—	—		15		
Input 'L' voltage	VIL	—	—	1.5	V	5	—	—
		—	—	3.0		10		
		—	—	4.0		15		
Input 'H' current	I <sub>IH</sub>	—	—	0.3	μA	15	VIH=15[V]	—
Input 'L' current	I <sub>IL</sub>	—	—	-0.3	μA	15	VIL=0[V]	—
Output 'H' voltage	VOH	4.95	—	—	V	5	IO=0[mA]	1
		9.95	—	—		10		
		14.95	—	—		15		
Output 'L' voltage	VOL	—	—	0.05	V	5	IO=0[mA]	2
		—	—	0.05		10		
		—	—	0.05		15		
Output 'H' current	IOH	-0.16	—	—	mA	5	VOH=4.6[V]	1
		-0.4	—	—		5	VOH=9.5[V]	
		-1.2	—	—		15	VOH=13.5[V]	
Output 'L' current	IOL	0.44	—	—	mA	5	VOL=0.4[V]	2
		1.1	—	—		10	VOL=0.5[V]	
		3.0	—	—		15	VOL=1.5[V]	
Static supply current	IDD	—	—	20	μA	5	VI=VSS or GND	—
		—	—	40		10		
		—	—	80		15		

Switching Characteristics (Unless otherwise noted VSS=0[V], Ta=25[°C], CL=50[pF])

Parameter	Symbol	Limits			Unit	VDD[V]	Condition	Fig. No
		Min	Typ	Max				
Output rising time	t <sub>TLH</sub>	—	180	—	ns	5	—	—
		—	90	—		10		
		—	65	—		15		
Output falling time	T <sub>T<sub>HL</sub></sub>	—	100	—	ns	5	—	—
		—	50	—		10		
		—	40	—		15		
Propagation delay time CLOCK, D→Q	t <sub>PLH</sub> t <sub>PHL</sub>	—	310	—	ns	5	—	3 · 4
		—	125	—		10		
		—	90	—		15		
Propagation delay time RESET→Q	t <sub>PLH</sub> t <sub>PHL</sub>	—	460	—	ns	5	—	5 · 6
		—	180	—		10		
		—	120	—		15		
Set up time	T <sub>su</sub>	—	100	—	ns	5	—	7 · 8
		—	50	—		10		
		—	40	—		15		
Minimum clock pulse width	t <sub>W(CLK)</sub>	—	185	—	ns	5	—	9
		—	85	—		10		
		—	55	—		15		
Minimum reset pulse width	t <sub>W(RST)</sub>	—	200	—	ns	5	—	10
		—	80	—		10		
		—	60	—		15		
Maximum clock frequency	f (CLK) Max.	—	20	—	MHz	5	—	—
		—	6.0	—		10		
		—	7.5	—		15		
Maximum clock rising/falling time	t <sub>r</sub> (CLK) t <sub>f</sub> (CLK)	—	100	—	μs	5	—	—
		—	40	—		10		
		—	15	—		15		
Input capacitance	C <sub>IN</sub>	—	5	—	pF	—	—	—

●Electrical Characteristics (BU4021B)

DC Characteristics (Unless otherwise noted VSS=0[V], Ta=25[°C])

Parameter	Symbol	Limits			Unit	VDD[V]	Condition	Fig. No
		Min	Typ	Max				
Input 'H' voltage	VIH	3.5	—	—	V	5	—	—
		7.0	—	—		10		
		11.0	—	—		15		
Input 'L' voltage	VIL	—	—	1.5	V	5	—	—
		—	—	3.0		10		
		—	—	4.0		15		
Input 'H' current	I <sub>IH</sub>	—	—	0.3	μA	15	VIH=15[V]	—
Input 'L' current	I <sub>IL</sub>	—	—	-0.3	μA	15	VIL=0[V]	—
Output 'H' voltage	VOH	4.95	—	—	V	5	IO=0[mA]	11
		9.95	—	—		10		
		14.95	—	—		15		
Output 'L' voltage	VOL	—	—	0.05	V	5	IO=0[mA]	12
		—	—	0.05		10		
		—	—	0.05		15		
Output 'H' current	IOH	-0.16	—	—	mA	5	VOH=4.6[V]	11
		-0.4	—	—		5	VOH=9.5[V]	
		-1.2	—	—		15	VOH=13.5[V]	
Output 'L' current	IOL	0.44	—	—	mA	5	VOL=0.4[V]	12
		1.1	—	—		10	VOL=0.5[V]	
		3.0	—	—		15	VOL=1.5[V]	
Static supply current	IDD	—	—	20	μA	5	VI=VDD or GND	—
		—	—	40		10		
		—	—	80		15		

Switching Characteristics (Unless otherwise noted VSS=0[V], Ta=25[°C], CL=50[pF])

Parameter	Symbol	Limits			Unit	VDD[V]	Condition	Fig. No
		Min	Typ	Max				
Output rising time	t <sub>TLH</sub>	—	180	—	ns	5	—	—
		—	90	—		10		
		—	65	—		15		
Output falling time	t <sub>THL</sub>	—	100	—	ns	5	—	—
		—	50	—		10		
		—	40	—		15		
"L" to "H" Propagation delay time CLOCK→Q P/S→Q	t <sub>PLH</sub>	—	400	—	ns	5	—	13 · 15
		—	170	—		10		
		—	115	—		15		
"H" to "L" Propagation delay time CLOCK→Q P/S→Q	t <sub>PHL</sub>	—	400	—	ns	5	—	14 · 16
		—	170	—		10		
		—	115	—		15		
Set up time	t <sub>su</sub>	—	150	—	ns	5	—	17
		—	50	—		10		
		—	30	—		15		
Minimum clock pulse width	t <sub>W(CLK)</sub>	—	150	—	ns	5	—	19
		—	75	—		10		
		—	40	—		15		
Maximum clock frequency	f (CLK) Max.	—	3.0	—	MHz	5	—	—
		—	6.0	—		10		
		—	8.0	—		15		
Maximum clock rising/falling time	tr(CLK) tf(CLK)	—	—	15	μs	5	—	—
		—	—	5.0		10		
		—	—	4.0		15		
Minimum P/S Control pulse width	t <sub>w(P/S)</sub>	—	150	—	ns	5	—	20
		—	75	—		10		
		—	40	—		15		
Input capacitance	C <sub>IN</sub>	—	5	—	pF	—	—	—

●Electrical Characteristics (BU4094BC)

DC Characteristics (Unless otherwise noted VSS=0[V], Ta=25[°C])

Parameter	Symbol	Limits			Unit	VDD[V]	Condition	Fig. No
		Min	Typ	Max				
Input 'H' voltage	VIH	3.5	—	—	V	5	—	—
		7.0	—	—		10		
		11.0	—	—		15		
Input 'L' voltage	VIL	—	—	1.5	V	5	—	—
		—	—	3.0		10		
		—	—	4.0		15		
Input 'H' current	I <sub>IH</sub>	—	—	0.3	μA	15	VIH=15[V]	—
Input 'L' current	I <sub>IL</sub>	—	—	-0.3	μA	15	VIL=0[V]	—
Output 'H' voltage	VOH	4.95	—	—	V	5	IO=0[mA]	21
		9.95	—	—		10		
		14.95	—	—		15		
Output 'L' voltage	VOL	—	—	0.05	V	5	IO=0[mA]	22
		—	—	0.05		10		
		—	—	0.05		15		
Output 'H' current	IOH	-0.44	—	—	mA	5	VOH=4.6[V]	21
		-1.1	—	—		5	VOH=9.5[V]	
		-3.0	—	—		15	VOH=13.5[V]	
Output 'L' current	IOL	0.44	—	—	mA	5	VOL=0.4[V]	22
		1.1	—	—		10	VOL=0.5[V]	
		3.0	—	—		15	VOL=1.5[V]	
Static supply current	IDD	—	—	5	μA	5	VI=VDD or GND	—
		—	—	10		10		
		—	—	20		15		

Switching Characteristics (Unless otherwise noted VSS=0[V], Ta=25[°C], CL=50[pF])

Parameter	Symbol	Limits			Unit	VDD[V]	Condition	Fig. No
		Min	Typ	Max				
Output rising time	t <sub>TLH</sub>	—	100	200	ns	5	—	—
		—	50	100		10		
		—	40	80		15		
Output falling time	t <sub>THL</sub>	—	100	200	ns	5	—	—
		—	50	100		10		
		—	40	80		15		
Propagation delay time CLOCK→QS	t <sub>PLH</sub> t <sub>PHL</sub>	—	350	600	ns	5	—	23
		—	125	250		10		
		—	95	190		15		
Propagation delay time CLOCK→Q'S	t <sub>PLH</sub> t <sub>PHL</sub>	—	230	460	ns	5	—	24
		—	110	220		10		
		—	75	150		15		
Propagation delay time CLOCK→QN	t <sub>PLH</sub> t <sub>PHL</sub>	—	420	840	ns	5	—	25
		—	195	390		10		
		—	135	270		15		
Propagation delay time STROBE→QN	t <sub>PLH</sub> t <sub>PHL</sub>	—	290	580	ns	5	—	26
		—	145	290		10		
		—	100	200		15		
3state Propagation delay time Output Enable→QN	t <sub>PHZ</sub> t <sub>PZH</sub>	—	140	280	ns	5	RL=1[kΩ]	27
		—	75	150		10		
		—	55	110		15		
3 state Propagation delay time Output Enable→QN	t <sub>PLZ</sub> t <sub>PZL</sub>	—	140	280	ns	5	RL=1[kΩ]	28
		—	75	150		10		
		—	55	110		15		
Minimum set up time DATA→CLOCK	tsu	—	20	125	ns	5	—	29
		—	8	55		10		
		—	6	35		15		
Minimum hold time CLOCK →DATA	tH	—	10	40	ns	5	—	30
		—	10	20		10		
		—	5	15		15		
Minimum clock pulse width	tW(CLK)	—	100	200	ns	5	—	31
		—	50	100		10		
		—	40	80		15		
Maximum clock rising/falling time	tr(CL) tf(CL)	NO Limit			μs	5	—	—
						10		
						15		
Maximum clock frequency	f CL	1.25	2.5	—	MHz	—	—	—
		2.5	5	—		—		
		3.0	12.5	—		—		
Minimum strobe pulse width	T <sub>WH</sub>	—	100	200	ns	—	—	—
		—	40	80		—		
		—	35	70		—		
Input capacitance	CIN	—	5	—	pF	—	—	—

●Electrical Characteristics (BU4538B)

DC Characteristics (Unless otherwise noted VSS=0[V], Ta=25[°C])

Parameter	Symbol	Limits			Unit	VDD[V]	Condition	Fig. No
		Min	Typ	Max				
Input 'H' voltage	VIH	3.5	—	—	V	5	—	—
		7.0	—	—		10		
		11.0	—	—		15		
Input 'L' voltage	VIL	—	—	1.5	V	5	—	—
		—	—	3.0		10		
		—	—	4.0		15		
Input 'H' current	I <sub>IH</sub>	—	—	0.3	μA	15	VIH=15[V]	—
Input 'L' current	I <sub>IL</sub>	—	—	-0.3	μA	15	VIL=0[V]	—
Output 'H' voltage	VOH	4.95	—	—	V	5	IO=0[mA]	—
		9.95	—	—		10		
		14.95	—	—		15		
Output 'L' voltage	VOL	—	—	0.05	V	5	IO=0[mA]	—
		—	—	0.05		10		
		—	—	0.05		15		
Output 'H' current	IOH	-0.16	—	—	mA	5	VOH=4.6[V]	—
		-0.4	—	—		5	VOH=9.5[V]	
		-1.2	—	—		15	VOH=13.5[V]	
Output 'L' current	IOL	0.44	—	—	mA	5	VOL=0.4[V]	—
		1.1	—	—		10	VOL=0.5[V]	
		3.0	—	—		15	VOL=1.5[V]	
Static supply current	IDD	—	—	20	μA	5	VI=VDD or GND	—
		—	—	40		10		
		—	—	80		15		

Switching Characteristics (Unless otherwise noted VSS=0[V], Ta=25[°C], CL=50[pF])

Parameter	Symbol	Limits			Unit	VDD[V]	Condition	Fig. No
		Min	Typ	Max				
Output rising time	t <sub>TLH</sub>	—	100	—	ns	5	—	—
		—	50	—		10		
		—	40	—		15		
Output falling time	t <sub>THL</sub>	—	100	—	ns	5	—	—
		—	50	—		10		
		—	40	—		15		
Propagation delay time A,B→Q, $\bar{Q}$	t <sub>PLH</sub> t <sub>PHL</sub>	—	300	—	ns	5	—	32 · 33
		—	150	—		10		
		—	100	—		15		
Propagation delay time CD→Q, $\bar{Q}$	t <sub>PLH</sub> t <sub>PHL</sub>	—	250	—	ns	5	—	34 · 35
		—	125	—		10		
		—	95	—		15		
Minimum input pulse width	t <sub>WIN</sub>	—	50	—	ns	5	—	36
		—	30	—		10		
		—	25	—		15		
Output pulse width 1	t <sub>WOUT1</sub>	185	200	215	μs	5	CX=2000[pF] RX=100[kΩ]	38
		185	200	215		10		
		185	200	215		15		
Output pulse width 2	t <sub>WOUT2</sub>	8.8	9.4	10.0	ms	5	CX=0.1[μF] RX=100[kΩ]	39
		8.8	9.4	10.0		10		
		8.8	9.4	10.0		15		
Minimum trigger time	t <sub>tr</sub>	—	0	—	ns	5	—	—
		—	0	—		10		
		—	0	—		15		
Input capacitance	C <sub>IN</sub>	—	5	—	pF	—	—	—

●Electrical Characteristics (BU4028B)

DC Characteristics (Unless otherwise noted VSS=0[V], Ta=25[°C])

Parameter	Symbol	Limits			Unit	VDD[V]	Condition	Fig. No
		Min	Typ	Max				
Input 'H' voltage	VIH	3.5	—	—	V	5	—	—
		7.0	—	—		10		
		11.0	—	—		15		
Input 'L' voltage	VIL	—	—	1.5	V	5	—	—
		—	—	3.0		10		
		—	—	4.0		15		
Input 'H' current	I <sub>IH</sub>	—	—	0.3	μA	15	VIH=15[V]	—
Input 'L' current	I <sub>IL</sub>	—	—	-0.3	μA	15	VIL=0[V]	—
Output 'H' voltage	VOH	4.95	—	—	V	5	IO=0[mA]	40
		9.95	—	—		10		
		14.95	—	—		15		
Output 'L' voltage	VOL	—	—	0.05	V	5	IO=0[mA]	41
		—	—	0.05		10		
		—	—	0.05		15		
Output 'H' current	IOH	-0.16	—	—	mA	5	VOH=4.6[V]	40
		-0.4	—	—		5	VOH=9.5[V]	
		-1.2	—	—		15	VOH=13.5[V]	
Output 'L' current	IOL	0.44	—	—	mA	5	VOL=0.4[V]	41
		1.1	—	—		10	VOL=0.5[V]	
		3.0	—	—		15	VOL=1.5[V]	
Static supply current	IDD	—	—	1	μA	5	VI=VDD or GND	—
		—	—	2		10		
		—	—	4		15		

Switching Characteristics (Unless otherwise noted VSS=0[V], Ta=25[°C], CL=50[pF])

Parameter	Symbol	Limits			Unit	VDD[V]	Condition	Fig. No
		Min	Typ	Max				
Output rising time	t <sub>TLH</sub>	—	180	—	ns	5	—	42
		—	90	—		10		
		—	65	—		15		
Output falling time	t <sub>THL</sub>	—	100	—	ns	5	—	43
		—	50	—		10		
		—	40	—		15		
"L" to "H" Propagation delay time	t <sub>PLH</sub>	—	300	—	ns	5	—	44
		—	130	—		10		
		—	90	—		15		
"H" to "L" Propagation delay time	t <sub>PHL</sub>	—	300	—	ns	5	—	45
		—	130	—		10		
		—	90	—		15		
Input capacitance	C <sub>IN</sub>	—	5	—	pF	—	—	—

● Electrical Characteristics Curves (BU4015B)

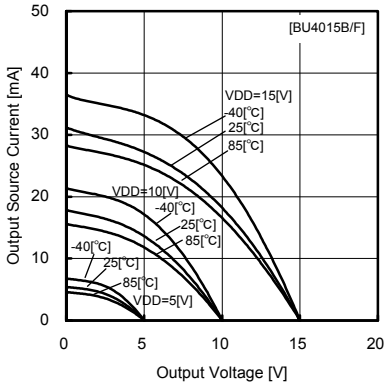

Fig.1 Output source current – voltage

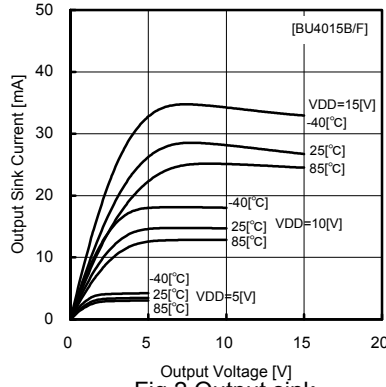

Fig.2 Output sink current – voltage

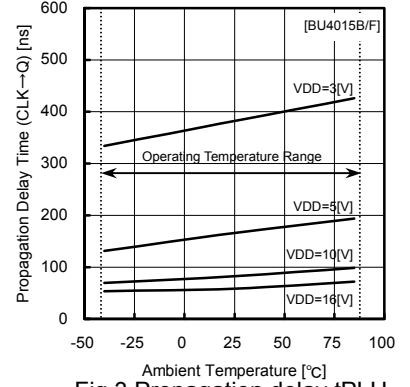

Fig.3 Propagation delay tPLH CLK→Q

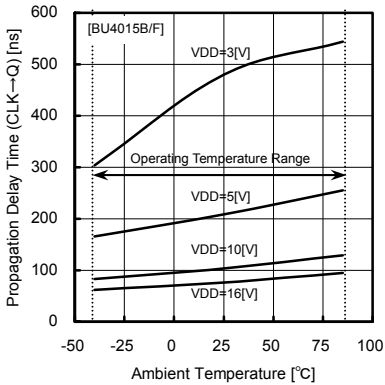

Fig.4 Propagation delay tPHL CLK→Q

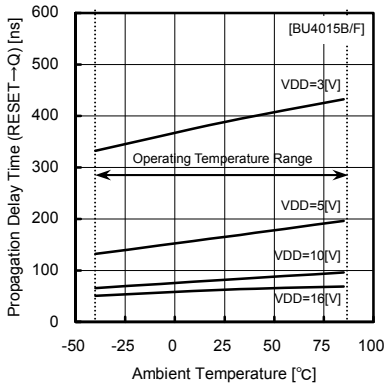

Fig.5 Propagation delay tPLH RESET→Q

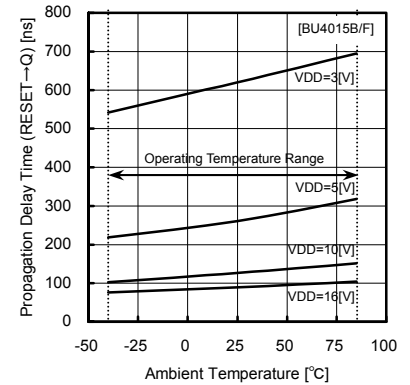

Fig.6 Propagation delay tPHL RESET→Q

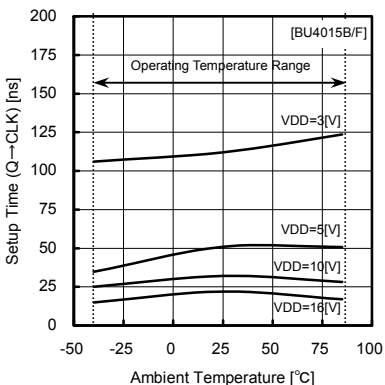

Fig.7 Set up time tsu Q→CLK

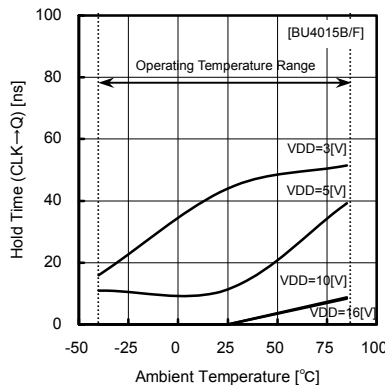

Fig.8 Hold time th CLK→Q

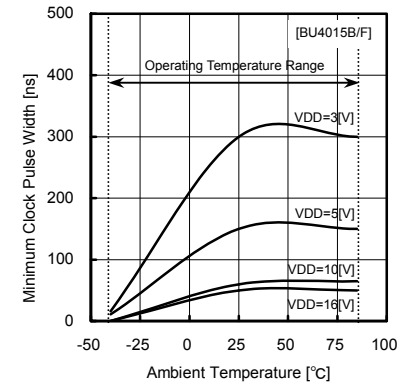

Fig.9 Minimum CLK pulse width

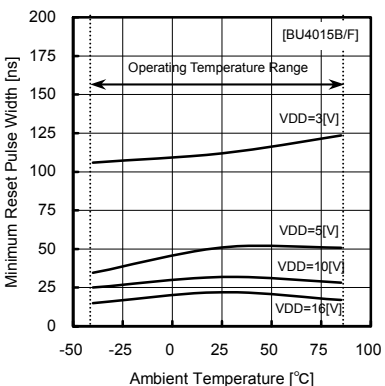
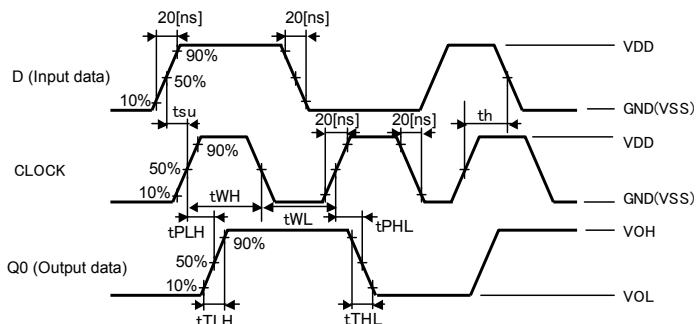

Fig.10 Minimum RESET pulse width

○ Switching characteristics



● Electrical Characteristics Curves (BU4021B)

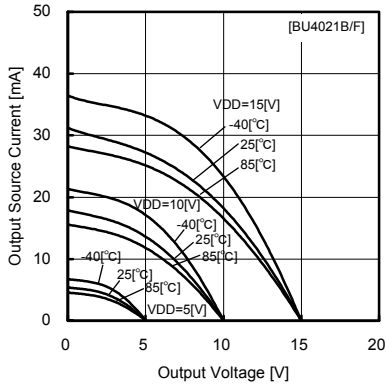

Fig. 11 Output source current - voltage

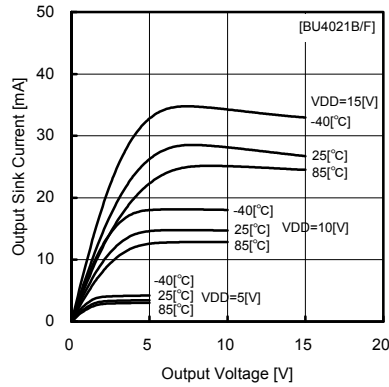

Fig. 12 Output sink current - voltage

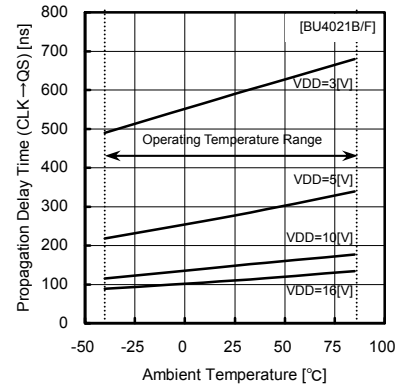

Fig. 13 Propagation delay tPLH CLK -> QS

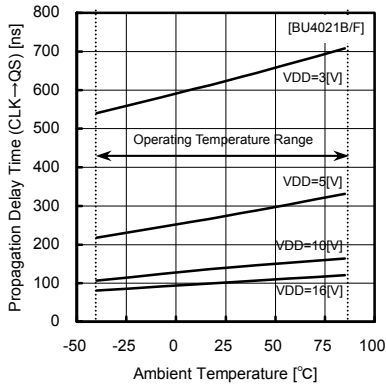

Fig. 14 Propagation delay tPHL CLK -> QS

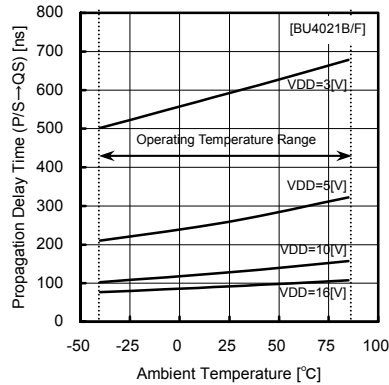

Fig. 15 Propagation delay tPLH P/S -> QS

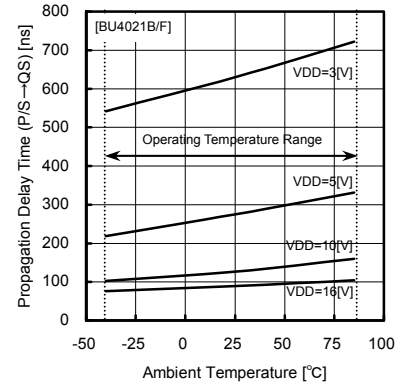

Fig. 16 Propagation delay tPHL P/S -> QS

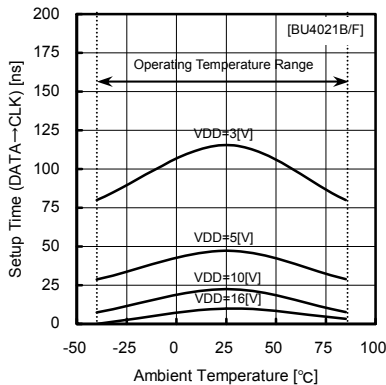

Fig. 17 Set up time tsu Q -> CLK

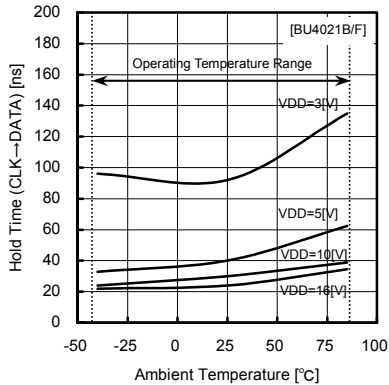

Fig. 18 Hold time th CLK -> Q

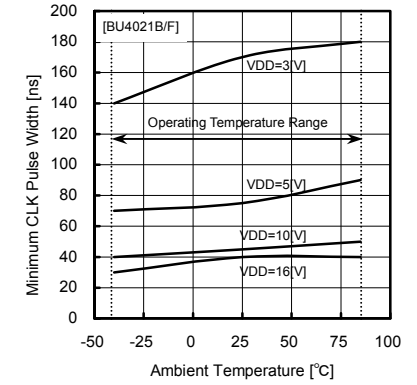

Fig. 19 Minimum CLK pulse width

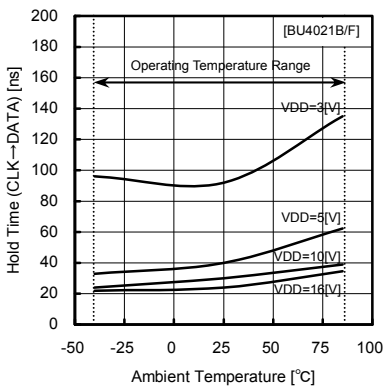
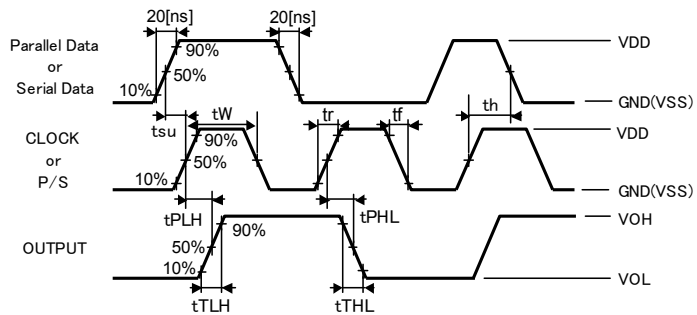

Fig. 20 Minimum P/S pulse width

○ Switching characteristics



● Electrical Characteristics Curves (BU4094BC)

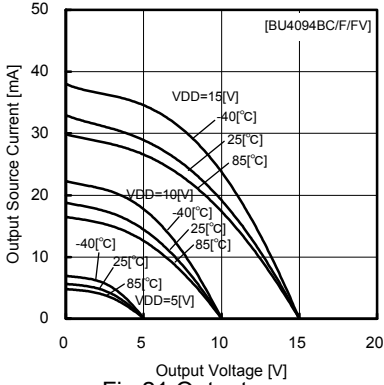

Fig.21 Output source current - voltage

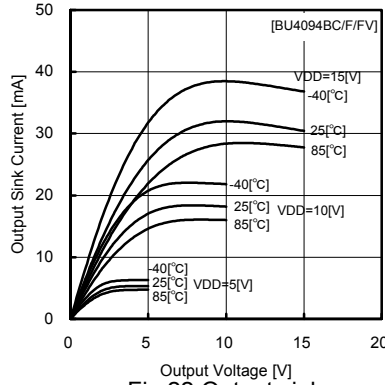

Fig.22 Output sink current - voltage

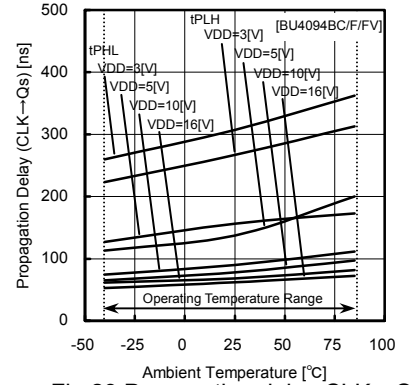

Fig.23 Propagation delay CLK -> QS

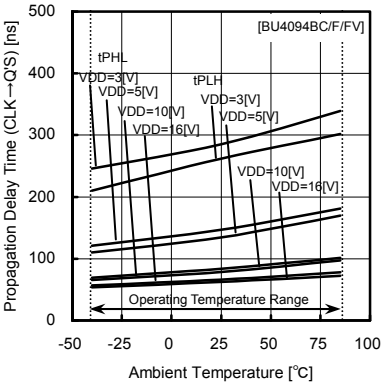

Fig.24 Propagation delay CLK -> Q'S

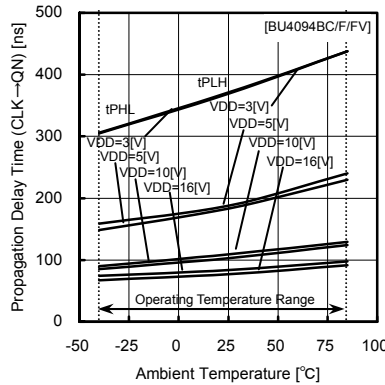

Fig.25 Propagation delay CLK -> QN

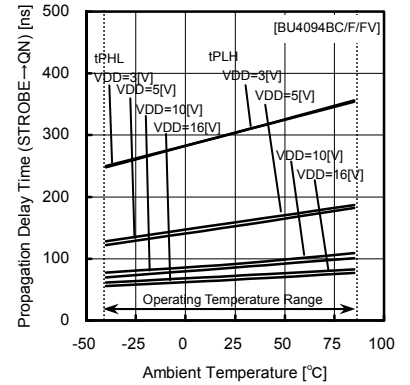

Fig.26 Propagation delay STROBE -> QN

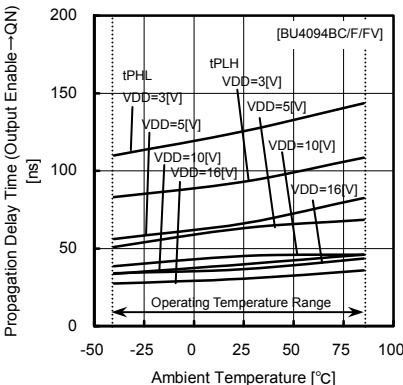

Fig.27 Propagation delay tPHZ Output Enable -> QN

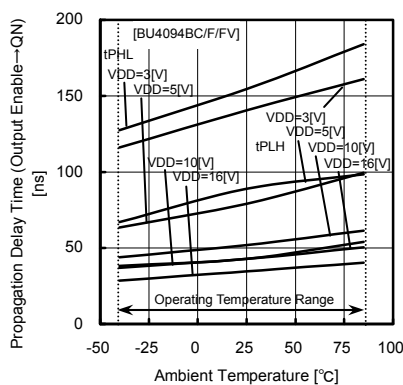

Fig.28 Propagation delay tPLZ Output Enable -> QN

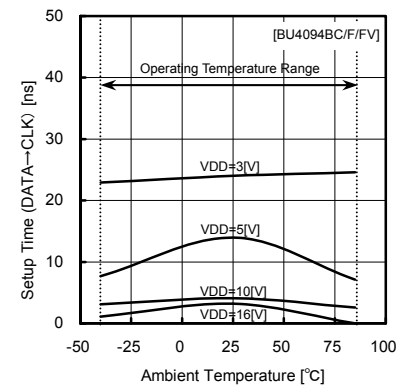

Fig.29 Set up time tsu DATA -> CLK

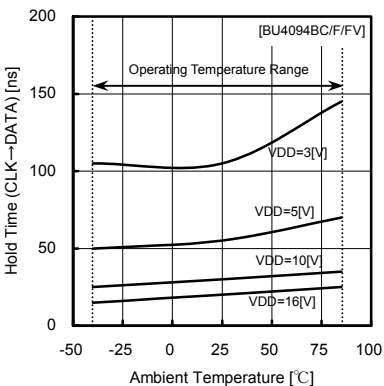

Fig.30 Hold time tH CLK -> DATA

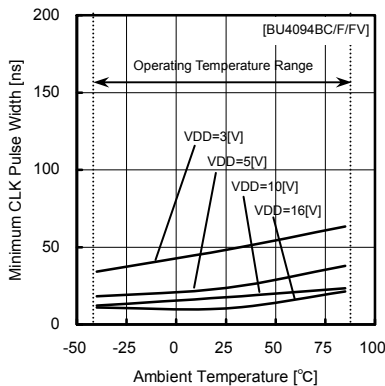

Fig.31 Minimum CLK pulse width tW(CLK)

○ Switching characteristics are stated on page 14.

● Electrical Characteristics Curves (BU4538B)

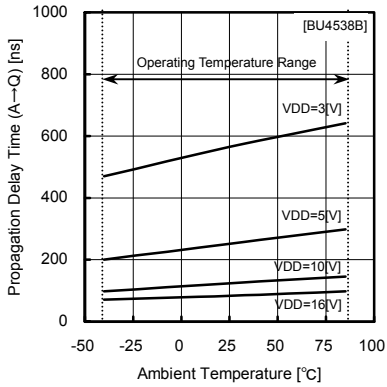

Fig.32 Propagation delay  $t_{PLH}$  A→Q

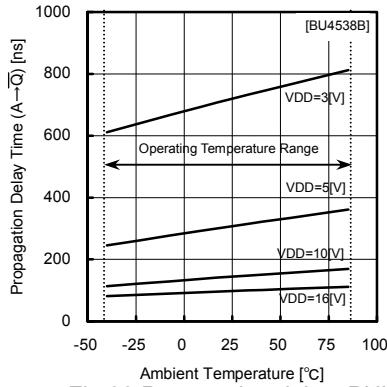

Fig.33 Propagation delay  $t_{PHL}$  A→Q

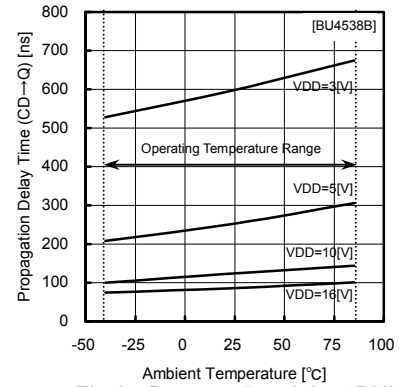

Fig.34 Propagation delay  $t_{PHL}$  CD→Q

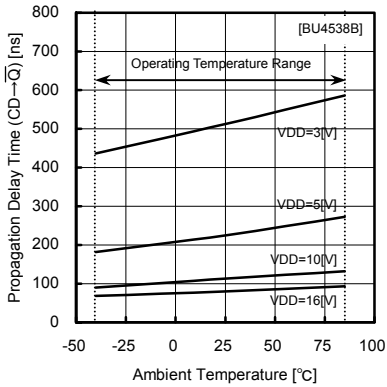

Fig.35 Propagation delay  $t_{PLH}$  CD→Q

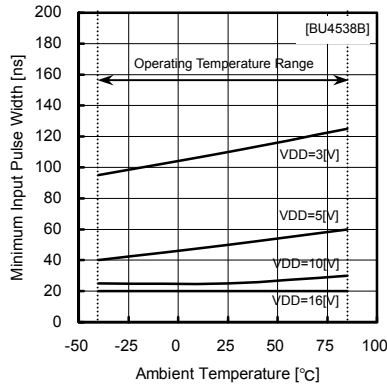

Fig.36 Minimum input pulse width  $t_{WIN}$

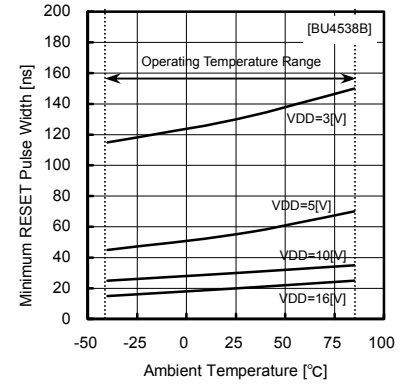

Fig.37 Minimum RESET pulse width  $t_{RESET}$

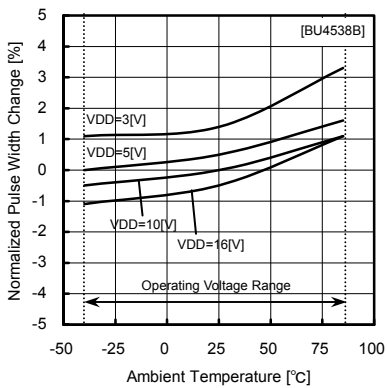

Fig.38 Output pulse width  $t_{WOUT1}$  (CX=2000[pF],RX=100[kΩ])

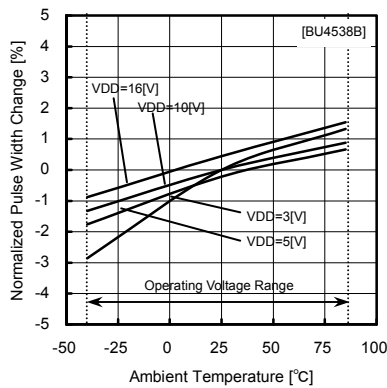
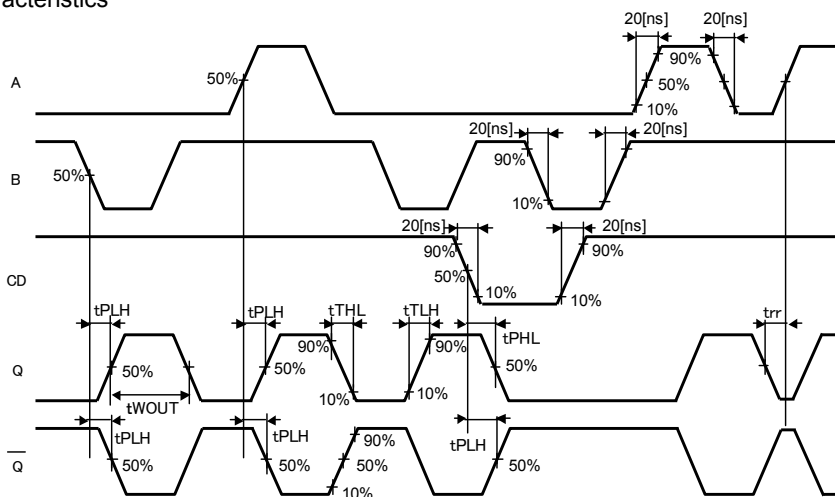

Fig.39 Output pulse width  $t_{WOUT2}$  (CX=0.1[μF],RX=100[kΩ])

○ Switching Characteristics



●Reference data (BU4028B)

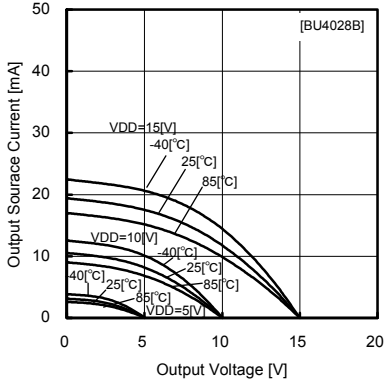

Fig.40 Output source current-voltage

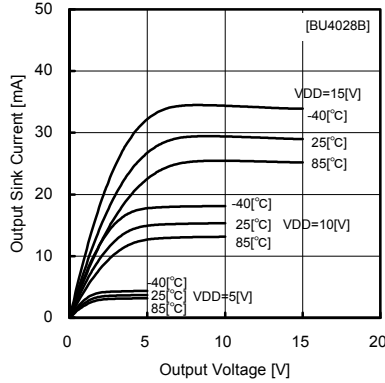

Fig.41 Output sink current-voltage

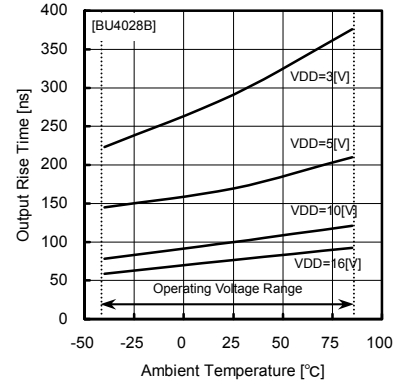

Fig.42 Propagation delay tTLH

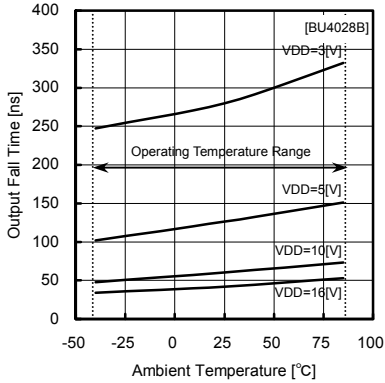

Fig.43 Propagation delay tTHL

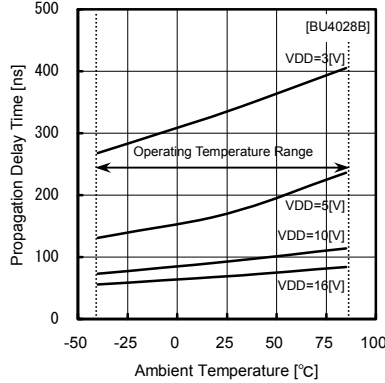

Fig.44 Propagation delay tPLH

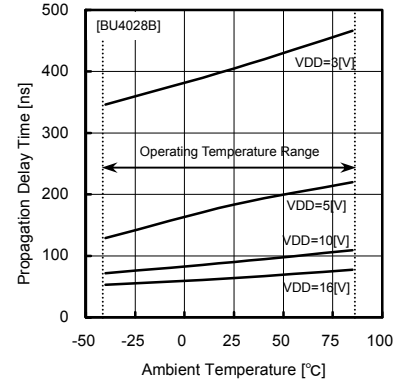

Fig.45 Propagation delay tPHL

(\* ) Switching characteristics is shown in P15.

●Description of BU4015B series model

Function : Dual 4-bit static shift register

1) Description of operation

Dual 4-bit static shift register of BU4015B is configured with 2 independent serial input/parallel output registers of the same 4-state.

Each register is provided with an independent clock and reset input having one series data input. Register state is the D type master/slave flip-flop. Data is shifted to the next stage during the rise time of the clock. Each register can be cleared by addition of "H" level to reset.

PIN arrangement

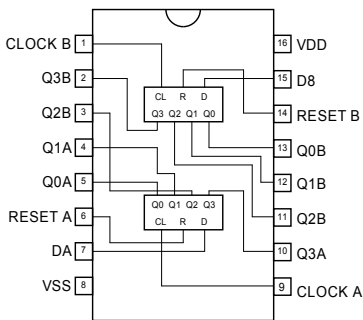

Block diagram

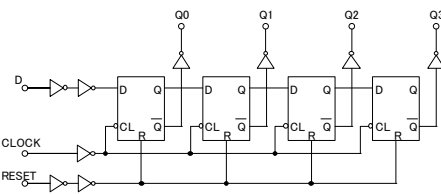

Truth table

CLOCK	D	RESET	Q0	Q1	Q2	Q3
↑	L	L	L	Q0	Q1	Q2
↑	H	L	H	Q0	Q1	Q2
↓	X	L	L	No Change		
X	X	H	L	L	L	L

X: Don't Care

PIN description

PIN No.	Symbol	I/O	Function
1	CLOCKB	I	Clock input (CHB)
2	Q3B	O	Output 3 (CHB)
3	Q2A	O	Output 2 (CHA)
4	Q1A	O	Output 1 (CHB)
5	Q0A	O	Output 0 (CHA)
6	RESETA	I	Reset input (CHA)
7	DA	I	Data input (CHA)
8	VSS	—	Power supply(-)
9	CLOCKA	I	Clock input (CHA)
10	Q3A	O	Output 3 (CHA)
11	Q2B	O	Output 2 (CHB)
12	Q1B	O	Output 1 (CHB)
13	Q0B	O	Output 0 (CHB)
14	RESETB	I	Reset input (CHB)
15	DB	I	Data input (CHB)
16	VDD	—	Power supply(+)

●Description of BU4021B series model

Function: 8-stage static shift register

1) Description of operation

BU4021B is an 8-bit static shift register capable of parallel input/series output and series input/series output. In parallel operation, DS (data) being asynchronous with the clock is inputted into each F/F and obtained at output. In series operation, DS (data) is triggered by clock.

When P/S input level is “H”, parallel operation is effective, and when P/S input level is “L”, series operation is effective.

PIN arrangement

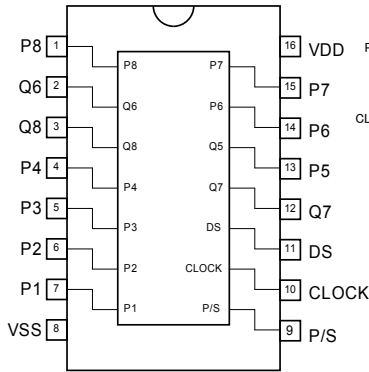

Block diagram

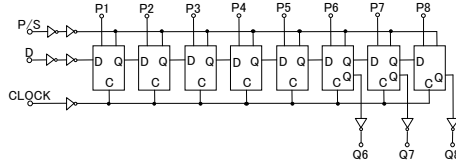

PIN description

PIN No.	Symbol	I/O	Function
1	P8	I	Parallel data input 8
2	Q6	O	Output 6
3	Q8	O	Output 8
4	P4	I	Parallel data input 4
5	P3	I	Parallel data input 3
6	P2	I	Parallel data input 2
7	P1	I	Parallel data input 1
8	VSS	—	Power supply(-)
9	P/S	I	Parallel/Serial control
10	CLOCK	I	Clock input
11	DS	I	Serial data input
12	Q7	O	Output 7
13	P5	I	Parallel data input 5
14	P6	I	Parallel data input 6
15	P7	I	Parallel data input 7
16	VDD	—	Power supply (+)

Truth table

CLOCK	D	RESET	Q0	Q1	Q2	Q3
↓	L	L	L	Q0	Q1	Q2
↓	H	L	H	Q0	Q1	Q2
↓	X	L	No Change			
X	X	H	L	L	L	L

CLOCK	DS	P/S	Dm	Qm*
↓	X	H	L	L
↓	X	H	H	H

X: Don't Care  
\*: Q6, Q7, Q8: outside

X: Don't Care

●Description of BU4094BC series model

Function: Dual 4-bit static shift register

1) Description of operation

BU4094BC is an 8-stage shift/store register provided in each stage with a data latch with 3-state output. Data read into shift register is read into the latch during the fall time of asynchronous STROBE input, and in the data transfer mode, output can be held. Data is passed through the latch and outputted when the STROBE is in “H” level. Because the parallel output becomes high impedance when the OUTPUT ENABLE terminal is set to “L” level by 3-state, the parallel output can be connected directly with the 8-bit pass line.

PIN arrangement

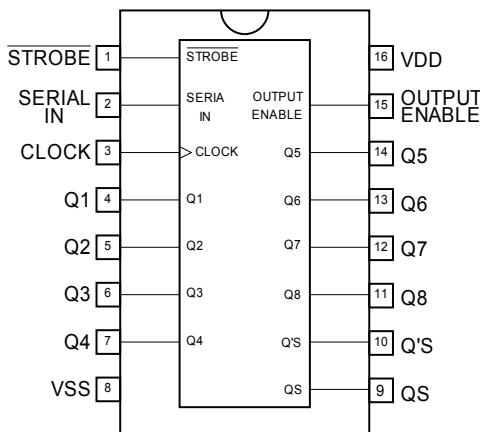

PIN description

PIN No.	Symbol	I/O	Function
1	STROBE	I	Latch input
2	SERIALIN	I	Data input
3	CLOCK	I	Clock input
4	Q1	O	Parallel data input Q1
5	Q2	O	Parallel data input Q2
6	Q3	O	Parallel data input Q3
7	Q4	O	Parallel data input Q4
8	VSS	—	Power supply(-)
9	QS	O	Serial data output QS
10	Q'S	O	Serial data output Q'S
11	Q8	O	Parallel data output Q8
12	Q7	O	Parallel data output Q7
13	Q6	O	Parallel data output Q6
14	Q5	O	Parallel data output Q5
15	ENABLE	I	Output enable
16	VDD	—	Power supply (+)

Block diagram

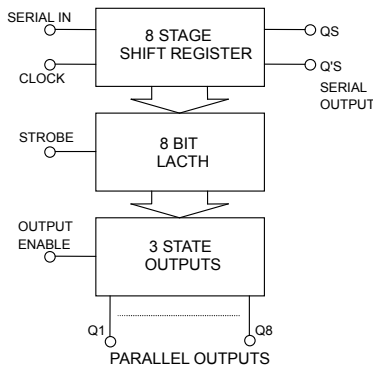

Truth table

CLOCK	OUTPUT ENABLE	STROBE	SERIAL IN	Parallel Output		Serial Output	
				Q1	Qn	Qs	Q's
	H	H	L	L	Qn-1	Q7	NC
	H	H	H	H	Qn-1	Q7	NC
	H	L	X	NC	NC	Q7	NC
	L	X	X	Z	Z	Q7	NC
	H	X	X	NC	NC	NC	Qs
	H	H	X	Z	Z	NC	Qs

○ Switching characteristics

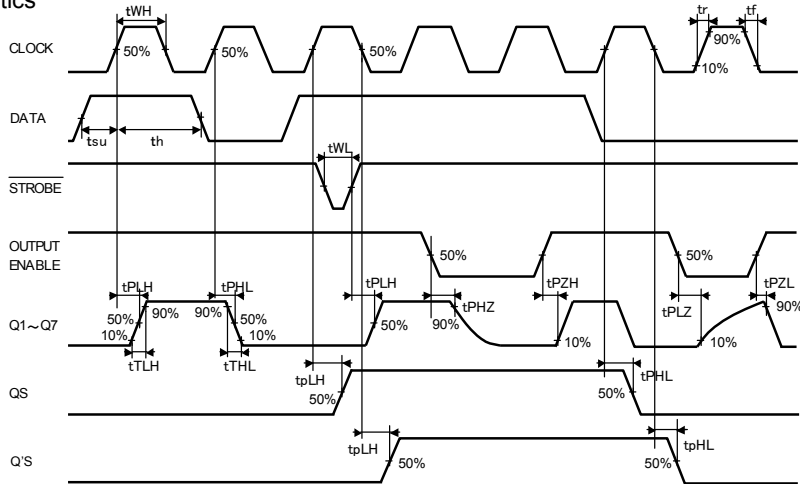

● Description of BU4538B series model

Function: Dual high accuracy monostable multivibrator

1) Description of operation

BU4538B is a re-triggerable monostable multi vibrator. Triggering is possible from either edge of the rise time and fall time of input pulse. Output pulse setting is determined by the time constant ( $R_x \cdot C_x$ ) of external  $R_x$  and  $C_x$ . Recommended output pulse amplitude is  $200[\mu s] \sim 1[s]$ .

(Cautions on use: In case of system power down, etc., electric charge accumulated in the capacity  $C_x$  is discharged to the VDD terminal through protective diode of 2 pins of 14 pins. When the electric current due to accumulated electric charge exceeds  $10[mA]$ , IC may be destructed. When a large capacity  $C_x$  is used, electric current flowing into the IC can be restricted by inserting the diode  $D_x$ .)

PIN arrangement

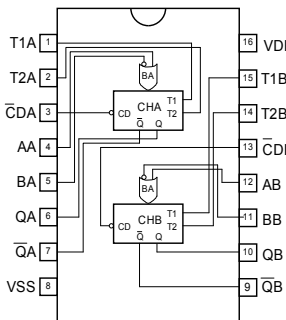

Block diagram

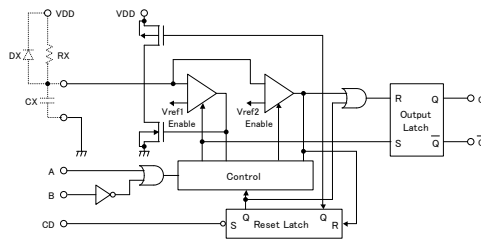

Truth table

INPUT			OUTPUT	
A	B	CD	Q	$\bar{Q}$
	H	H		
	L	H	L	H
H		H	L	H
L		H		
X	H	L	L	H

X: Don't Care

PIN description

PIN No.	Symbol	I/O	Function
1	T1A	—	Passive component connection pin 1(CHA)
2	T2A	—	Passive component connection pin 2(CHA)
3	CDA	I	Reset input (CHA)
4	AA	I	Input A(CHA)
5	BA	I	Input B(CHA)
6	QA	O	Output Q(CHA)
7	QAB	O	Output QB(CHA)
8	VSS	—	Power supply(-)
9	QBB	O	Output QB(CHB)
10	QB	O	Output Q(CHB)
11	BB	I	Input B(CHB)
12	AB	I	Input A(CHB)
13	CCB	I	Reset input (CHB)
14	T2B	—	Passive component connection pin 1(CHB)
15	T1B	—	Passive component connection pin 2(CHB)
16	VDD	—	Power supply (+)

●Description of BU4028B series model

Function: BCD to decimal decoder

1) Description of operation

BU4028B is a decoder to convert BCD signals into decimal signals. Out of 10 outputs of Q0~Q9, output applicable for the input code of A~D becomes "H" level and all other outputs become "L" level. When the input of D is made to be inhibit input by using 3 inputs of A~C, this product can be used as a 1-OF-8 decoder.

PIN arrangement

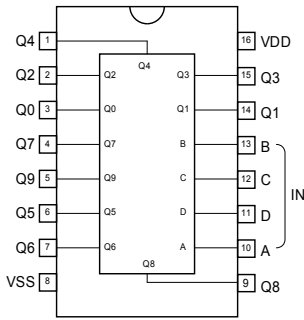

Block diagram

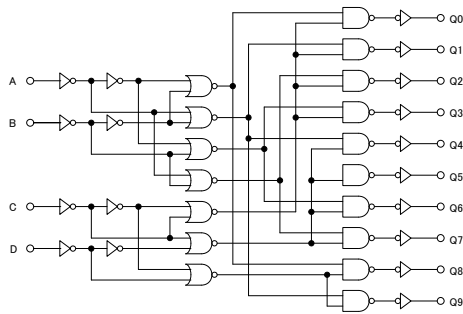

Truth table

INPUT				OUTPUT									
D	C	B	A	Q9	Q8	Q7	Q6	Q5	Q4	Q3	Q2	Q1	Q0
L	L	L	L	L	L	L	L	L	L	L	L	L	H
L	L	L	H	L	L	L	L	L	L	L	L	H	L
L	L	H	L	L	L	L	L	L	L	L	H	L	L
L	L	H	H	L	L	L	L	L	L	H	L	L	L
L	H	L	L	L	L	L	L	L	H	L	L	L	L
L	H	L	H	L	L	L	L	H	L	L	L	L	L
L	H	H	L	L	L	L	H	L	L	L	L	L	L
L	H	H	H	L	L	H	L	L	L	L	L	L	L
H	L	L	L	L	H	L	L	L	L	L	L	L	L
H	L	L	H	L	L	L	L	L	L	L	L	L	L
H	L	H	L	L	L	L	L	L	L	L	L	L	L
H	L	H	H	L	L	L	L	L	L	L	L	L	L
H	H	L	L	L	L	L	L	L	L	L	L	L	L
H	H	L	H	L	L	L	L	L	L	L	L	L	L
H	H	H	L	L	L	L	L	L	L	L	L	L	L
H	H	H	H	L	L	L	L	L	L	L	L	L	L

Switching characteristics

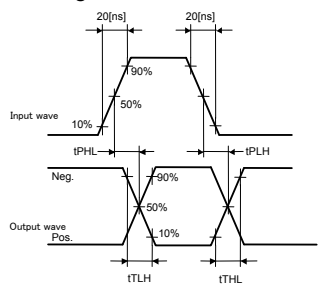

PIN description

PIN No.	Symbol	I/O	Function
1	Q4	O	Output 4
2	Q2	O	Output 2
3	Q0	O	Output 0
4	Q7	O	Output 7
5	Q9	O	Output 9
6	Q5	O	Output 5
7	Q6	O	Output 6
8	VSS	—	Power supply(-)
9	Q8	O	Output 8
10	A	I	Input A
11	D	I	Input D
12	C	I	Input C
13	B	I	Input B
14	Q1	O	Output 1
15	Q3	O	Output 3
16	VDD	—	Power supply(+)

●Operation Notes

1. Absolute maximum ratings

An excess in the absolute maximum ratings, such as supply voltage, temperature range of operating conditions, etc., can break down the devices, thus making impossible to identify breaking mode, such as a short circuit or an open circuit. If any over rated values will expect to exceed the absolute maximum ratings, consider adding circuit protection devices, such as fuses.

2. Connecting the power supply connector backward

Connecting of the power supply in reverse polarity can damage IC. Take precautions when connecting the power supply lines. An external direction diode can be added.

3. Power supply lines

Design PCB layout pattern to provide low impedance GND and supply lines. To obtain a low noise ground and supply line, separate the ground section and supply lines of the digital and analog blocks. Furthermore, for all power supply terminals to ICs, connect a capacitor between the power supply and the GND terminal. When applying electrolytic capacitors in the circuit, not that capacitance characteristic values are reduced at low temperatures.

4. GND voltage

The potential of GND pin must be minimum potential in all operating conditions.

5. Thermal design

Use a thermal design that allows for a sufficient margin in light of the power dissipation (Pd) in actual operating conditions.

6. Inter-pin shorts and mounting errors

Use caution when positioning the IC for mounting on printed circuit boards. The IC may be damaged if there is any connection error or if pins are shorted together.

7. Actions in strong electromagnetic field

Use caution when using the IC in the presence of a strong electromagnetic field as doing so may cause the IC to malfunction.

8. Testing on application boards

When testing the IC on an application board, connecting a capacitor to a pin with low impedance subjects the IC to stress. Always discharge capacitors after each process or step. Always turn the IC's power supply off before connecting it to or removing it from a jig or fixture during the inspection process. Ground the IC during assembly steps as an antistatic measure. Use similar precaution when transporting or storing the IC.

9. Ground Wiring Pattern

When using both small signal and large current GND patterns, it is recommended to isolate the two ground patterns, placing a single ground point at the ground potential of application so that the pattern wiring resistance and voltage variations caused by large currents do not cause variations in the small signal ground voltage. Be careful not to change the GND wiring pattern of any external components, either.

10. Unused input terminals

Connect all unused input terminals to VDD or VSS in order to prevent excessive current or oscillation

Insertion of a resistor (100kΩ approx.) is also recommended.

●Dimension

**DIP16**

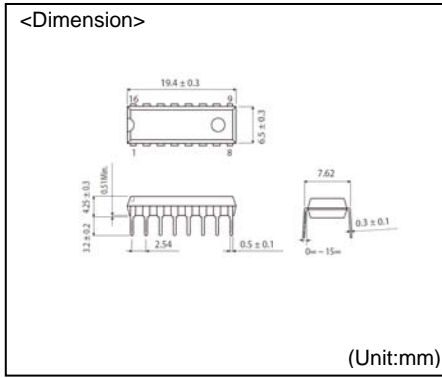

**SOP16**

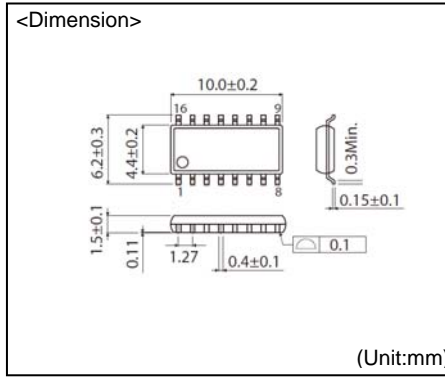

**SSOP-B16**

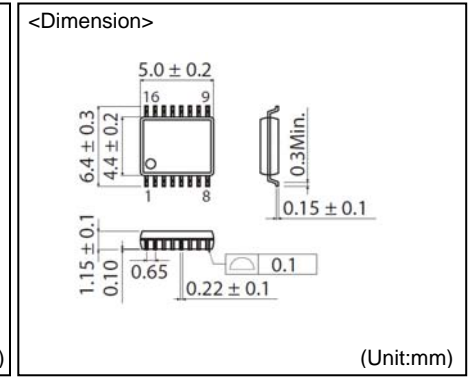

●Part Number Explanation



Part Number

- BU4015B    • BU4538B
- BU4021B    • BU4028B
- BU4094BC

Package Type

- Blank : DIP16
- F : SOP16
- FV : SSOP-B16

Package and forming specification

- Blank : Container tube
- E2 : Embossed tape reel  
Pin 1 opposite of feeding side

**DIP16**

<Packing information>

Container	Tube
Quantity	1,000pcs
Direction of feed	Direction of products is fixed in a container tube.

※Please order in multiples of the minimum package quantity.

**SOP16, SSOP-B16**

<Tape and Reel information>

Tape	Embossed carrier tape
Quantity	2500pcs
Direction of feed	E2 (The direction is the 1pin of product is at the upper left when you hold reel on the left hand and you pull out the tape on the right hand)

Reel      1Pin      Direction of feed

※When you order , please order in times the amount of package quantity.

### Notes

- No technical content pages of this document may be reproduced in any form or transmitted by any means without prior permission of ROHM CO.,LTD.
- The contents described herein are subject to change without notice. The specifications for the product described in this document are for reference only. Upon actual use, therefore, please request that specifications to be separately delivered.
- Application circuit diagrams and circuit constants contained herein are shown as examples of standard use and operation. Please pay careful attention to the peripheral conditions when designing circuits and deciding upon circuit constants in the set.
- Any data, including, but not limited to application circuit diagrams information, described herein are intended only as illustrations of such devices and not as the specifications for such devices. ROHM CO.,LTD. disclaims any warranty that any use of such devices shall be free from infringement of any third party's intellectual property rights or other proprietary rights, and further, assumes no liability of whatsoever nature in the event of any such infringement, or arising from or connected with or related to the use of such devices.
- Upon the sale of any such devices, other than for buyer's right to use such devices itself, resell or otherwise dispose of the same, no express or implied right or license to practice or commercially exploit any intellectual property rights or other proprietary rights owned or controlled by
- ROHM CO., LTD. is granted to any such buyer.
- Products listed in this document are no antiradiation design.

The products listed in this document are designed to be used with ordinary electronic equipment or devices (such as audio visual equipment, office-automation equipment, communications devices, electrical appliances and electronic toys).

Should you intend to use these products with equipment or devices which require an extremely high level of reliability and the malfunction of which would directly endanger human life (such as medical instruments, transportation equipment, aerospace machinery, nuclear-reactor controllers, fuel controllers and other safety devices), please be sure to consult with our sales representative in advance.

It is our top priority to supply products with the utmost quality and reliability. However, there is always a chance of failure due to unexpected factors. Therefore, please take into account the derating characteristics and allow for sufficient safety features, such as extra margin, anti-flammability, and fail-safe measures when designing in order to prevent possible accidents that may result in bodily harm or fire caused by component failure. ROHM cannot be held responsible for any damages arising from the use of the products under conditions out of the range of the specifications or due to non-compliance with the NOTES specified in this catalog.

Thank you for your accessing to ROHM product informations.

More detail product informations and catalogs are available, please contact your nearest sales office.

**ROHM** Customer Support System

THE AMERICAS / EUROPE / ASIA / JAPAN

[www.rohm.com](http://www.rohm.com)

Contact us : [webmaster@rohm.co.jp](mailto:webmaster@rohm.co.jp)