

ZN460, ZN460AM, ZN460CP

ULTRA LOW NOISE WIDEBAND PREAMPLIFIER

The ZN460 is a versatile high performance AC preamplifier, designed for applications requiring ultra low noise such as infra-red imaging and low noise wideband amplifiers e.g microphone, acoustic emission, transducer bridge amplifier. The matching of open loop gain, coupled with small physical size, makes the ZN460 ideal for multichannel amplification.

The programmable gain feature allows variable detector gain factors to be trimmed out. The programmable bandwidth feature allows the noise bandwidth to be reduced to the required signal bandwidth, thus minimising the wideband output noise.

FEATURES

- High Controlled Gain : 60dB \pm 1dB typical
- Programmable Gain : 50-60dB typical
- Programmable Bandwidth : 6MHz downwards
- Low Noise : 40 Ω Equivalent Noise Resistance, or 800pV/ $\sqrt{\text{Hz}}$
- Low Supply Current : <3mA from 5V

ABSOLUTE MAXIMUM RATINGS

Supply voltage	6 Volts
Operating Temperature Range:	
for ZN460 and ZN460AM	-55 to +125°C
for ZN460CP	0 to +70°C
Storage Temperature Range	-55 to +125°C

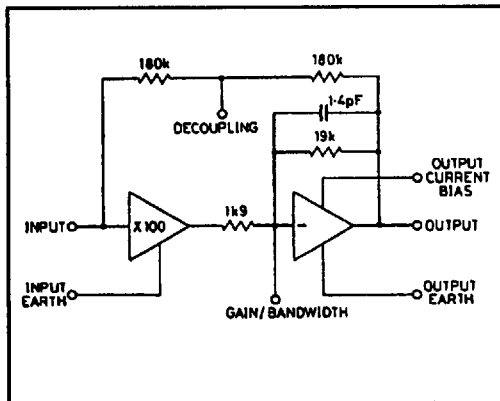
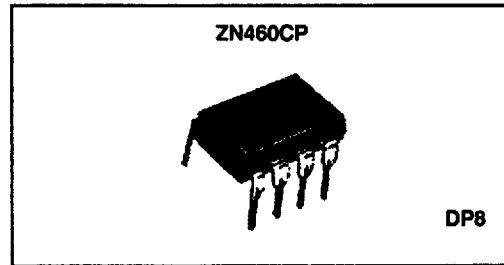
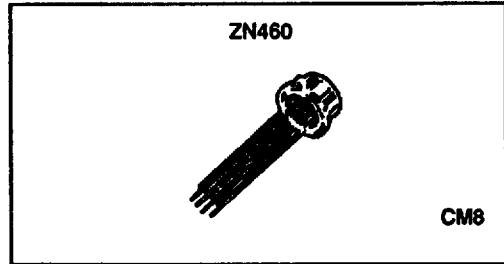
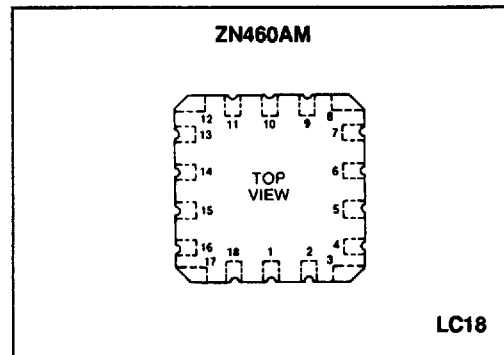

Fig.1 Circuit diagram



ELECTRICAL CHARACTERISTICS

Test conditions (unless otherwise stated):

$$(V_{cc} = 5V, T_{amb} = 25^{\circ}C)$$

Parameter	Min.	Typ.	Max.	Units	Conditions
Supply Current	2.0	2.5	3.0	mA	
Voltage Gain	59	60	61	dB	10KHz (Note 1)
TC of Voltage Gain		-0.2		%/°C	
V _{cc} Coefficient of Voltage Gain		25		%/V	
Cut-off Frequency		6		MHz	3dB down (Note 1)
Input Resistance	3.5	7		kΩ	10KHz
Input Capacitance		80		pF	Note 2
Noise Resistance		40		Ω	R _s = 0
White Noise Voltage		800	1100	pV/√Hz	R _s = 0
L.F. Spot Noise		3		nV/√Hz	R _s = 0, f = 25Hz
White Noise Current		1		pA/√Hz	
Output Level	1.5	2.0	2.5	V	
Output Swing		4		V _{pp}	R _F = ∞
	2			V _{pp}	R _F = 6KΩ
Supply Voltage Coefficient of Output Level		0.34		V/V	
Output Current Limit	0.6	0.8	1.1	mA	Note 3
Total Harmonic Distortion		0.15		%	1 V _{pp} at 10KHz
Output Resistance		75		Ω	10KHz
Supply Rejection Ratio		42.5		dB	
Delay Time		20		ns	Small signal
Delay Time		40		ns	100mV rms input
Positive Input Overdrive			10	mA	
Negative Input Overdrive			-5	V	

Note 1: Without external components

Note 2: In P.C.B. The input capacitance may be reduced to 25pF by screening between output and input.

Note 3: Sink current without external bias resistor

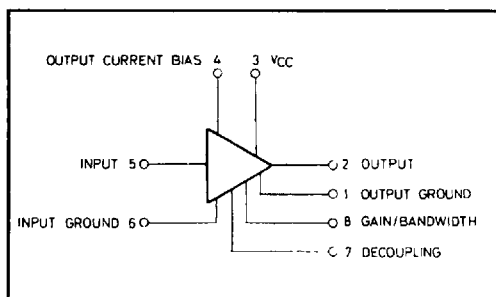

Fig.2 Pinning configuration - ZN460 and ZN460CP

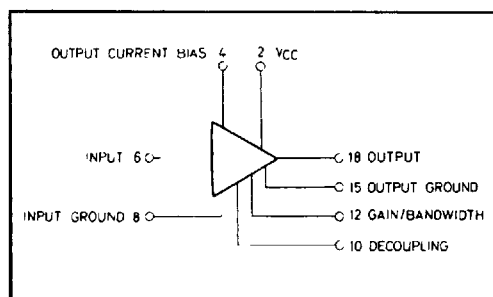

Fig.3 Pinning configuration - ZN460AM

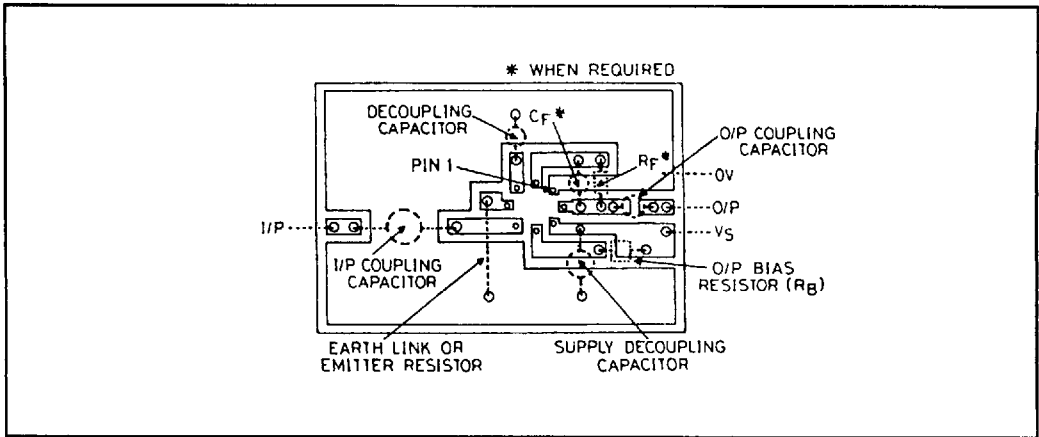

Fig.6 PCB Layout - ZN460

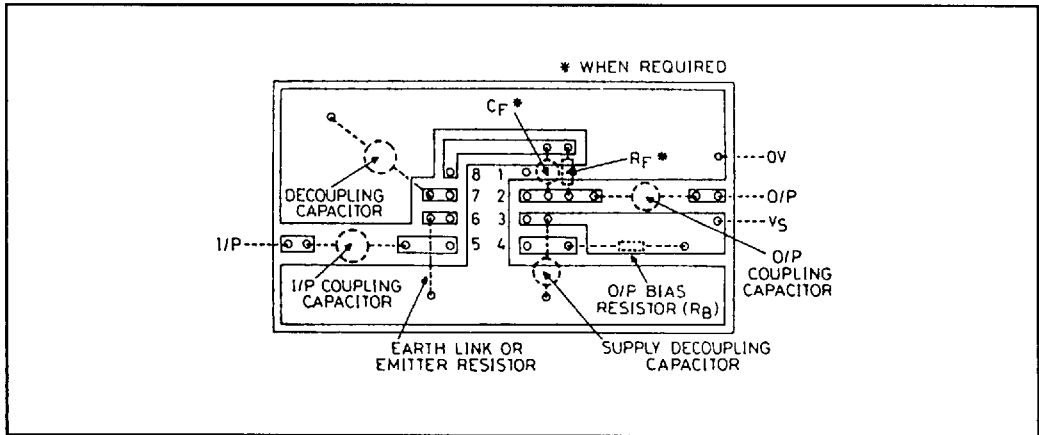

Fig.7 PCB Layout - ZN460CP

TYPICAL CHARACTERISTICS

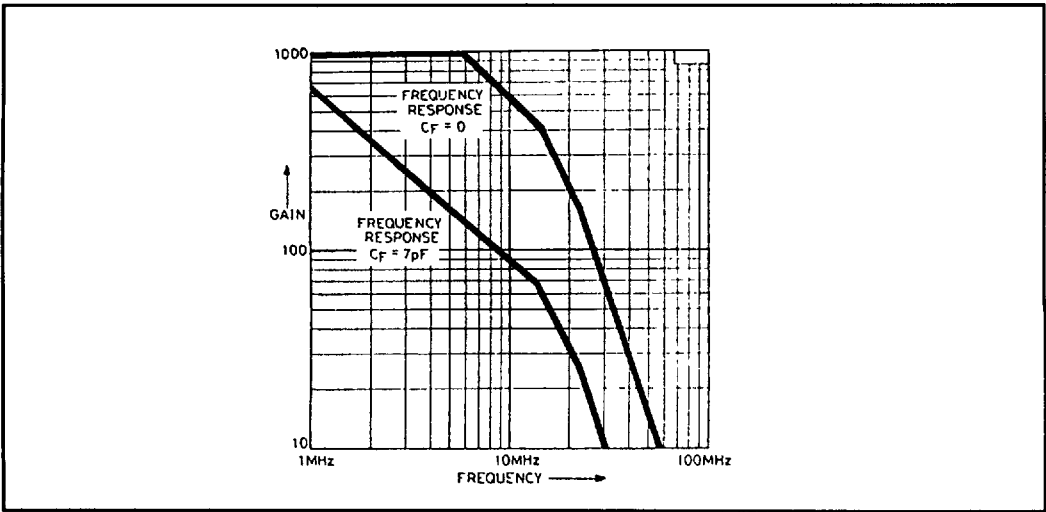

Fig.8 Gain V_s Frequency ($R_F = \infty$)

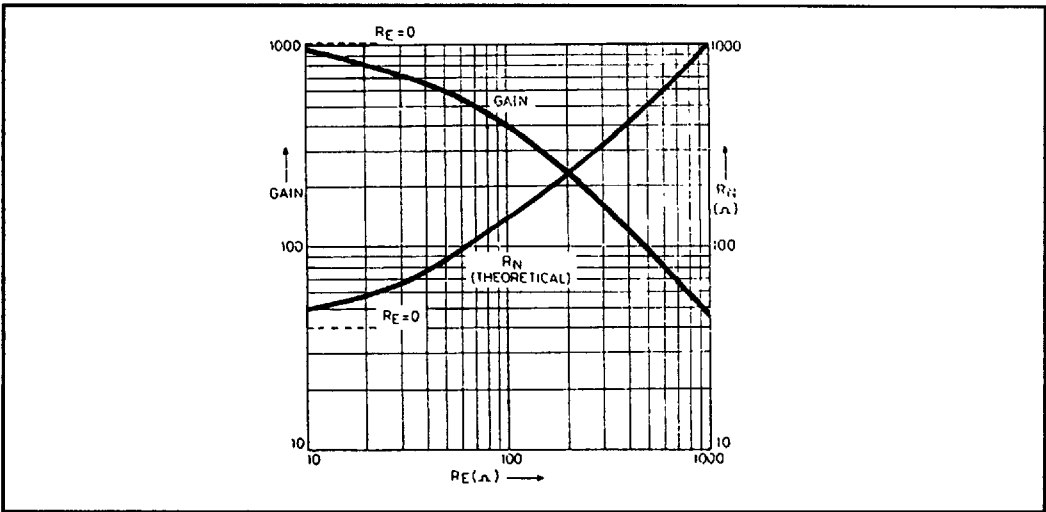

Fig.9 Gain and noise resistance V_s emitter resistance ($R_F = \infty$)

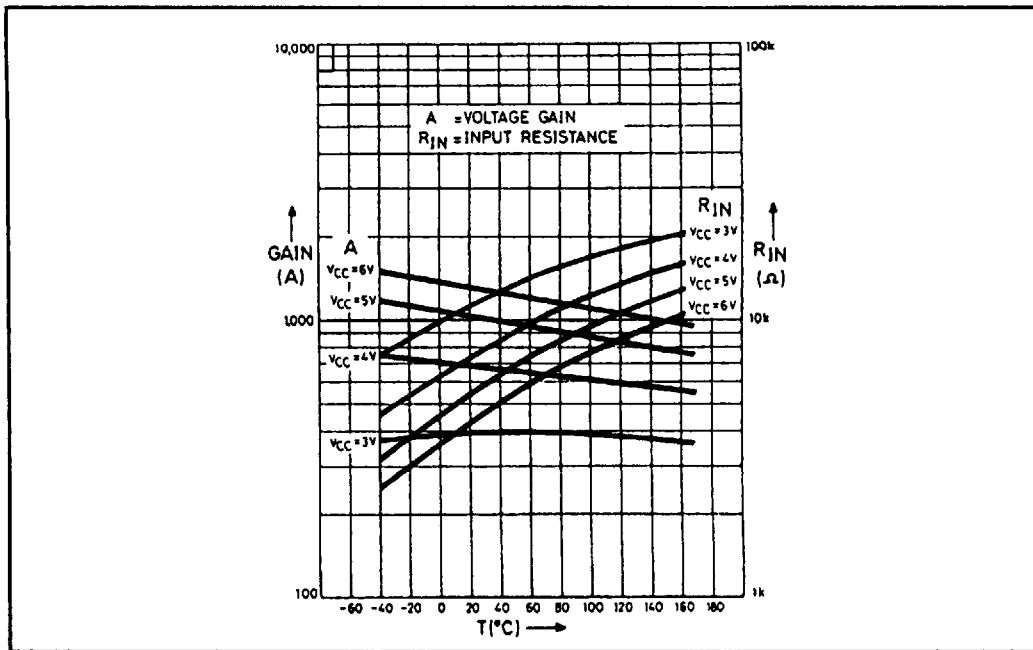

Fig.10 Gain and Input Impedance

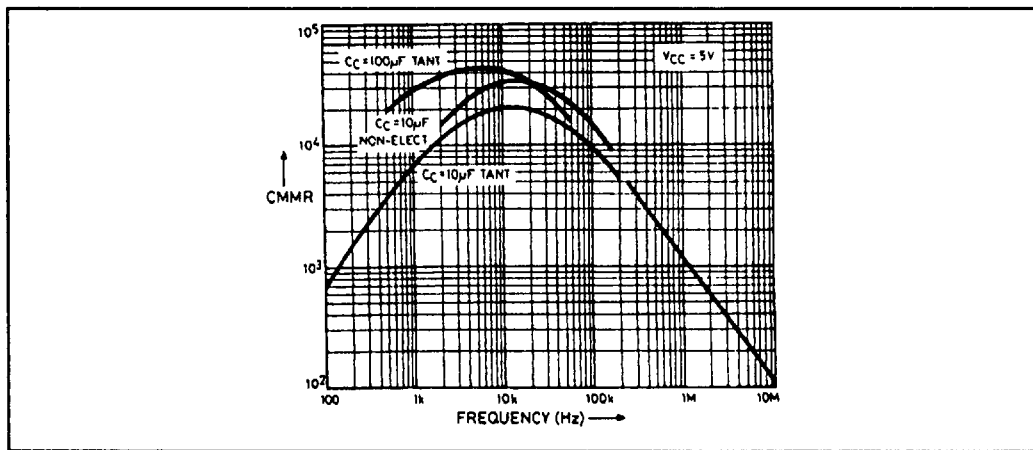

Fig.11 Common Mode Rejection Vs Frequency
(Measured between input earth and output earth)

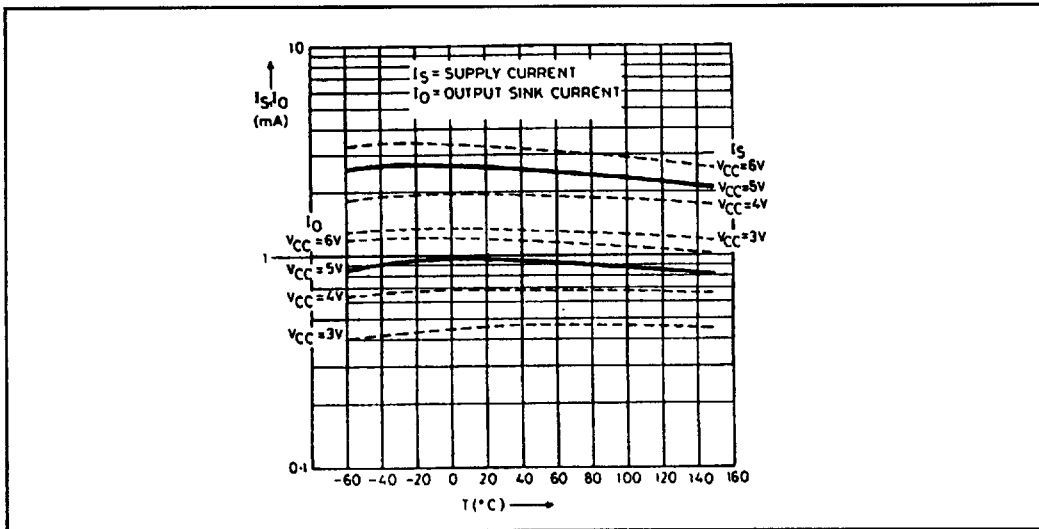

Fig.12 Supply current and output sink current

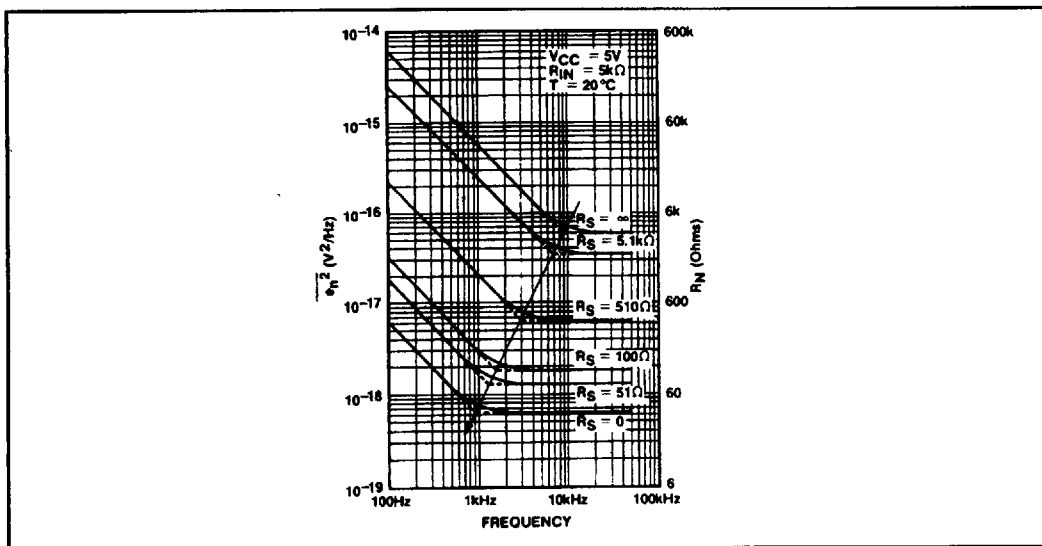

Fig.13 Noise voltage

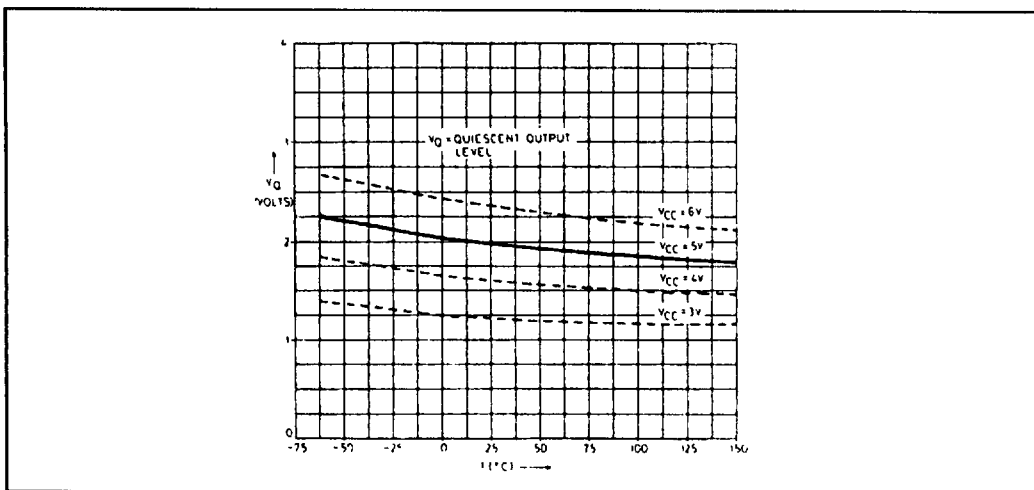

Fig.13 Quiescent Output Level