

THIS DRAWING IS UNPUBLISHED. RELEASED FOR PUBLICATION JAN , 2005.  
 © COPYRIGHT 2005 BY TYCO ELECTRONICS CORPORATION. ALL RIGHTS RESERVED.

LOC	DIST	REVISIONS					
E	B	P	LTR	DESCRIPTION	DATE	DWN	APVD
		B		ECO-09-003420	14 Feb 09	RITA	BOB

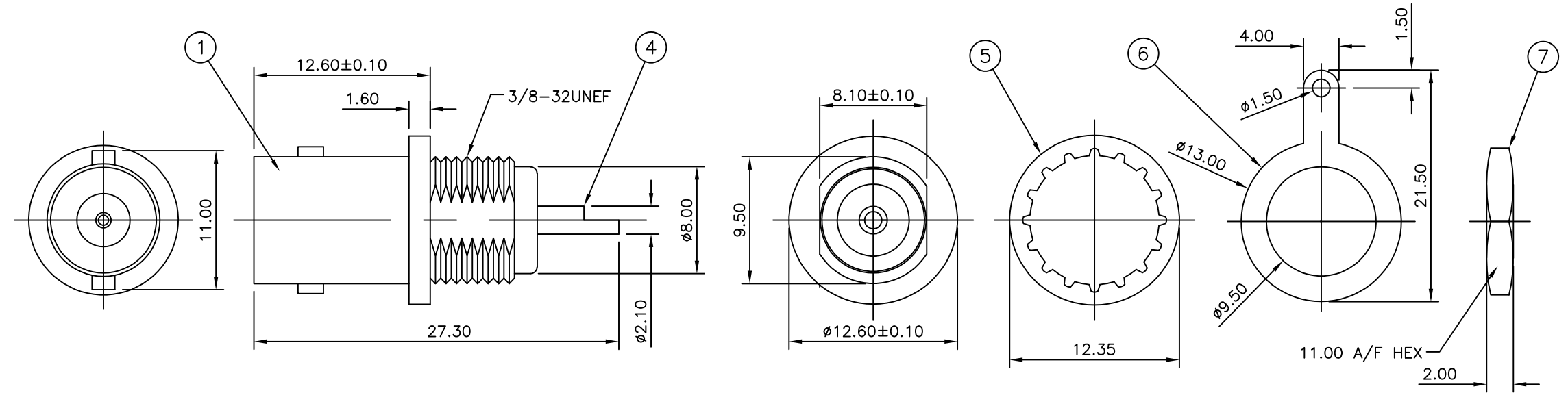

- NOTES**
- 1 100 TRAY PACK IN ACCORDANCE WITH AMP SPEC 107-3275
  - 2 SINGLE PACK IN ACCORDANCE WITH AMP SPEC 107-3275
  - 3 Au PLATING OVER Ni PLATING OVER Cu PLATING
  - 4 Ni PLATING OVER Cu PLATING
  - 5. FOR TECHNICAL DATA REFER TO YOUR LOCAL TYCO ELECTRONICS SALES OFFICE
  - 6. ALL DIMENSIONS ARE NOMINAL FOR REFERENCE ONLY UNLESS OTHERWISE STATED

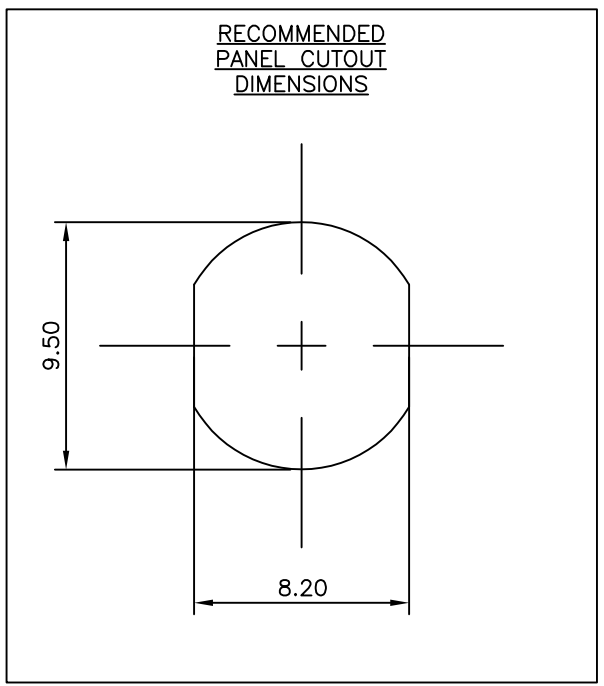
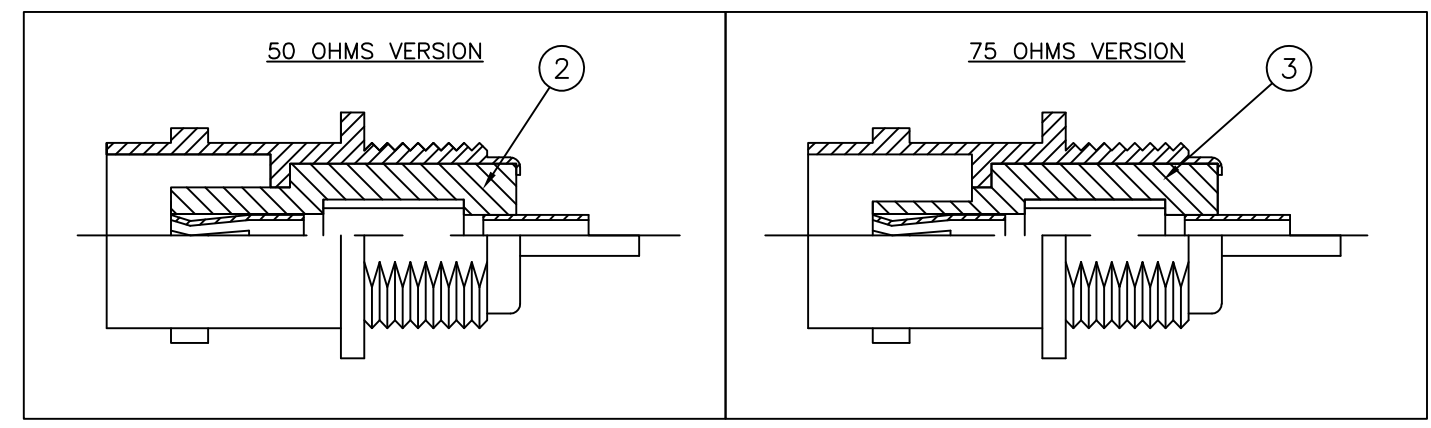

					1	1	1	1	BRASS	4	HEX NUT	7
					1	1	1	1	BRASS	4	SOLDER TAG	6
					1	1	1	1	STEEL	4	LOCK WASHER	5
					1	1	1	1	PHOS BRONZE	3	CONTACT	4
					1	1	-	-	POLYMETHYLPENTENE	3	INSULATOR	3
					-	-	1	1	POLYMETHYLPENTENE	2	INSULATOR	2
					1	1	-	-	ZINC ALLOY	4	BODY	1
					5--3	5--2	5--1	5--0				
					4	4	4	4				
QUANTITY PER ASSY										PARTS LIST		

THIS DRAWING IS A CONTROLLED DOCUMENT.		DWN	RITA ZUO	14 Feb 09	Tyco Electronics Corporation Kunshan, Jiangsu, PRC 215312			
		CHK	ANSON MA	14 Feb 09				
		APVD	BOB ZHAO	14 Feb 09	NAME			
		PRODUCT SPEC			BNC BULKHEAD SOCKET FRONT MOUNT WITH SOLDER TAG			
		APPLICATION SPEC			108-112000			
		WEIGHT			-			
MATERIAL		FINISH			SIZE	CAGE CODE	DRAWING NO	RESTRICTED TO
SEE TABLE		-			A3	00779	C-1634523	-
CUSTOMER DRAWING					SCALE	SHEET	REV	
					NTS	1 OF 1	B	