

Table of Contents

1 Features	1	8.2 Functional Block Diagram	19
2 Applications	1	8.3 Feature Description	19
3 Description	1	8.4 Device Functional Modes	23
4 Revision History	2	9 Application and Implementation	25
5 Pin Configuration and Functions	3	9.1 Application Information	25
6 Specifications	3	9.2 Typical Application	25
6.1 Absolute Maximum Ratings	3	10 Power Supply Recommendations	26
6.2 ESD Ratings	4	11 Layout	27
6.3 ESD Ratings, IEC Specification	4	11.1 Layout Guidelines	27
6.4 Recommended Operating Conditions	4	11.2 Layout Example	28
6.5 Thermal Information	4	12 Device and Documentation Support	29
6.6 Power Supply Characteristics	5	12.1 Documentation Support	29
6.7 Electrical Characteristics	5	12.2 Receiving Notification of Documentation Updates	29
6.8 AC Switching Characteristics	8	12.3 Community Resources	29
6.9 Typical Characteristics	9	12.4 Trademarks	29
7 Parameter Measurement Information	10	12.5 Electrostatic Discharge Caution	30
8 Detailed Description	19	12.6 Glossary	30
8.1 Overview	19	13 Mechanical, Packaging, and Orderable Information	30

4 Revision History

NOTE: Page numbers for previous revisions may differ from page numbers in the current version.

DATE	REVISION	NOTES
October 2017	*	Initial release.

5 Pin Configuration and Functions

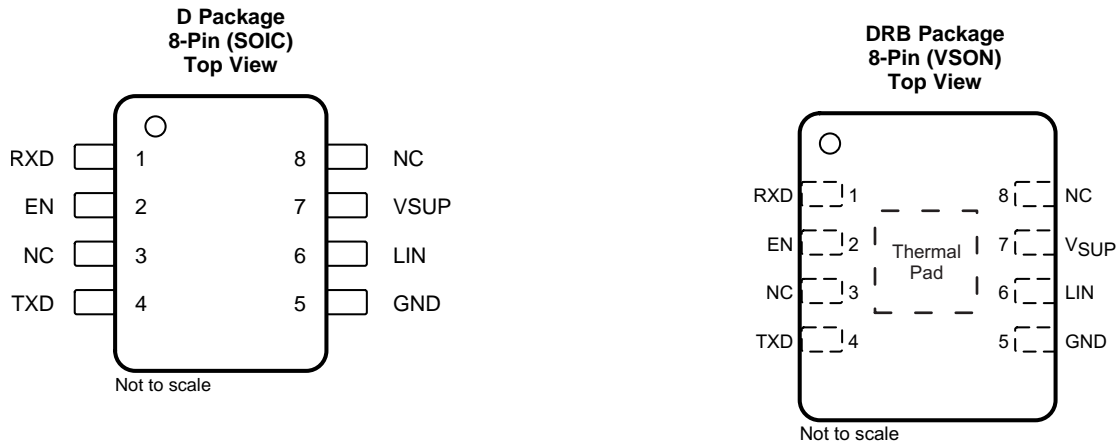

Pin Functions

PIN		Type	DESCRIPTION
NO.	NAME		
1	RXD	D O	RXD output (open-drain) interface reporting state of LIN bus voltage
2	EN	D I	Enable input - High put the device in normal operation mode and low put the device in sleep mode
3	NC	–	Not connected
4	TXD	D I	TXD input interface to control state of LIN output - Internal pulled to ground
5	GND	GND	Ground
6	LIN	HV I/O	LIN bus single-wire transmitter and receiver
7	V _{SUP}	Supply	Device supply voltage (connected to battery in series with external reverse blocking diode)
8	NC	–	Not connected
DRB Thermal Pad	GND	GND	Ground and should be soldered

6 Specifications

6.1 Absolute Maximum Ratings

over operating free-air temperature range (unless otherwise noted)⁽¹⁾

		MIN	MAX	UNIT
V _{SUP}	Supply voltage range (ISO/DIS 17987)	–0.3	60	V
V _{LIN}	LIN Bus input voltage (ISO/DIS 17987)	–58	58	V
V _{LOGIC}	Logic Pin Voltage (RXD, TXD, EN)	–0.3	5.5	V
T _J	Junction temperature range	–55	150	°C
Storage temperature, T _{stg}	Storage temperature range	–65	165	

(1) Stresses beyond those listed under *Absolute Maximum Ratings* may cause permanent damage to the device. These are stress ratings only, which do not imply functional operation of the device at these or any other conditions beyond those indicated under *Recommended Operating Conditions*. Exposure to absolute-maximum-rated conditions for extended periods may affect device reliability.

6.2 ESD Ratings

			VALUE	UNIT
$V_{(ESD)}$ Electrostatic discharge	Human-body model (HBM), per ANSI/ESDA/JEDEC JS-001 ⁽¹⁾	Pins TXD, RXD, EN ⁽²⁾	±4000	V
		Pins LIN bus, Vsup ⁽³⁾	±8000	
	Charged-device model (CDM), per JEDEC specification JESD22-C101 ⁽⁴⁾	All pins	±1500	

- (1) JEDEC document JEP155 states that 500-V HBM allows safe manufacturing with a standard ESD control process. Manufacturing with less than 500-V HBM is possible with the necessary precautions.
- (2) Tested in accordance to AEC-Q100-002
- (3) Test method based upon AEC-Q100-002, LIN bus and V_{SUP} are stressed with respect to GND.
- (4) JEDEC document JEP157 states that 250-V CDM allows safe manufacturing with a standard ESD control process. Manufacturing with less than 250-V CDM is possible with the necessary precautions.

6.3 ESD Ratings, IEC Specification

			VALUE	UNIT
IEC 61000-4-2 according to IBEE EMC test spec ⁽¹⁾	LIN , Vsup terminal to GND ⁽²⁾		±8000	V
ISO7637-2 & IEC 62215-3 Transients according to IBEE LIN EMC test spec ⁽³⁾	LIN , Vsup	Pulse 1	-100	V
		Pulse 2	75	V
		Pulse 3a	-150	V
		Pulse 3b	100	V
Powered ESD Performance SAEJ2962-1	SAEJ2962-1 ⁽⁴⁾	Contact	±8000	V
		Air Discharge	±25000	V

- (1) IEC 61000-4-2 is a system level ESD test. Results given here are specific to the IBEE LIN EMC Test specification conditions. Different system level configurations may lead to different results
- (2) Testing performed at 3rd party IBEE Zwickau test house, test report available upon request.
- (3) ISO7637 is a system level transient test. Results given here are specific to the IBEE LIN EMC Test specification conditions. Different system level configurations may lead to different results.
- (4) SAEJ2962-1 Testing performed at 3rd party US3 approved EMC test facility, test report available upon request.

6.4 Recommended Operating Conditions

over operating free-air temperature range (unless otherwise noted)

		MIN	NOM	MAX	UNIT
V_{SUP}	Supply boltage	4		48	V
V_{LIN}	LIN bus input voltage	0		48	V
V_{LOGIC}	Logic pin voltage (RXD, TXD, EN)	0		5.25	V
T_A	Operational free-air temperature (see Thermal Information table)	-40		125	°C

6.5 Thermal Information

THERMAL METRIC ⁽¹⁾		TLIN2029-Q1		UNIT
		D	DRB	
		8 PINS	8 PINS	
$R_{\theta JA}$	Junction-to-ambient thermal resistance	115.5	48.5	°C/W
$R_{\theta JC(top)}$	Junction-to-case (top) thermal resistance	58.7	55.5	°C/W
$R_{\theta JB}$	Junction-to-board thermal resistance	58.9	22.2	°C/W
Ψ_{JT}	Junction-to-top characterization parameter	14.1	1.2	°C/W
Ψ_{JB}	Junction-to-board characterization parameter	58.2	22.2	°C/W
$R_{\theta JC(bot)}$	Junction-to-case (bottom) thermal resistance	n/a	4.8	°C/W

- (1) For more information about traditional and new thermal metrics, see the [Semiconductor and IC Package Thermal Metrics](#) application report.

6.6 Power Supply Characteristics

Over operating free-air temperature range (unless otherwise noted)

PARAMETER		TEST CONDITIONS	MIN	TYP	MAX	UNIT
V _{SUP}	Operational supply voltage (ISO/DIS 17987 Param 10, 53)	Device is operational beyond the LIN defined nominal supply voltage range See Figure 8 and Figure 9	4		48	V
V _{SUP}	Nominal supply voltage (ISO/DIS 17987 Param 10, 53): Normal Mode: Ramp V _{SUP} while LIN signal is a 10 kHz square wave with 50 % duty cycle and 18V swing. Watch RXD	Normal and Standby Modes: Ramp V _{SUP} while LIN signal is a 10 kHz square wave with 50 % duty cycle and 36 V swing. See Figure 8 and Figure 9	4		48	V
		Sleep Mode	4		48	V
U _{VSUP}	Under voltage V _{SUP} threshold		3		3.75	V
U _{VHYS}	Delta hysteresis voltage for V _{SUP} under voltage threshold			0.2		V
I _{CC}	Supply current	Normal Mode: EN = high, bus dominant; total bus load where R _{LIN} ≥ 500 Ω and C _{LIN} ≤ 10 nF (See Figure 14),		1.2	5	mA
		Standby Mode: EN = low, bus dominant; total bus load where R _{LIN} ≥ 500 Ω and C _{LIN} ≤ 10 nF (See Figure 14),		1	2.1	mA
I _{CC}	Supply current	Normal Mode: EN = high, Bus recessive: LIN = V _{SUP} ,		400	700	μA
		Standby Mode: EN = low, bus recessive: LIN = V _{SUP} ,		20	35	μA
		Sleep Mode: 4.0 V < V _{SUP} ≤ 27 V, LIN = V _{SUP} , EN = 0 V, TXD and RXD floating		9	15	μA
		Sleep Mode: 27 V < V _{SUP} ≤ 48 V, LIN = V _{SUP} , EN = 0 V, TXD and RXD floating			30	μA
P _D	Power dissipation in normal mode (dominant)					mW
TSD	Thermal shutdown temperature		165			°C
TSD _(HYS)	Thermal shutdown hysteresis			25		°C

6.7 Electrical Characteristics

over operating free-air temperature range (unless otherwise noted)

PARAMETER		TEST CONDITIONS	MIN	TYP	MAX	UNIT
RXD OUTPUT PIN (OPEN DRAIN)						
V _{OL}	Output Low voltage	Based upon external pull-up to V _{CC}			0.6	V
I _{OL}	Low level output current, open drain	LIN = 0 V, RXD = 0.4 V	1.5			mA
I _{ILG}	Leakage current, high-level	LIN = V _{SUP} , RXD = 5 V	-5	0	5	μA
TXD INPUT PIN						
V _{IL}	Low level input voltage		-0.3		0.8	V
V _{IH}	High level input voltage		2		5.5	V
I _{IL}	Low level input leakage current	TXD = low	-5	0	5	μA
R _{TXD}	Internal pull-down resistor value		125	350	800	kΩ
LIN PIN (REFERENCED TO V_{SUP})						
V _{OH}	High level output voltage	LIN recessive, TXD = high, I _O = 0 mA, V _{SUP} = 4 V to 48 V	0.85 x V _{SUP}			V
		LIN dominant, TXD = high, V _{SUP} = 4 V ≤ V _{OH} < 7 V	3.0			V

Electrical Characteristics (continued)

over operating free-air temperature range (unless otherwise noted)

PARAMETER	TEST CONDITIONS	MIN	TYP	MAX	UNIT	
V _{OL}	Low level output voltage			0.2 x V _{SUP}	V	
		LIN dominant, TXD = low, V _{SUP} = 7 V to 48 V		1.2		
V _{SUP_NON_OP}	V _{SUP} where Impact of recessive LIN bus < 5% (ISO/DIS 17987 Param , 54/56)	TXD & RXD open LIN = 4 V to 58 V	-0.3	58	V	
I _{BUS_LIM}	Limiting current (ISO/DIS 17987 Param , 57)	TXD = 0 V, V _{LIN} = 48 V, R _{MEAS} = 440 Ω, V _{SUP} = 48 V, V _{BUSdom} < 4.518 V Figure 13	40	90	200	mA
I _{BUS_PAS_dom}	Receiver leakage current, dominant (ISO/DIS 17987 Param , 58)	LIN = 0 V, V _{SUP} = 24 V Driver off/recessive Figure 14	-1			mA
I _{BUS_PAS_rec1}	Receiver leakage current, recessive (ISO/DIS 17987 Param , 59)	LIN ≥ V _{SUP} , 4 V ≤ V _{SUP} ≤ 48 V Driver off; Figure 15			20	μA
I _{BUS_PAS_rec2}	Receiver leakage current, recessive (ISO/DIS 17987 Param , 59)	LIN = V _{SUP} , Driver off; Figure 15	-5		5	μA
I _{BUS_NO_GND}	Leakage current, loss of ground (ISO/DIS 17987 Param , 60)	GND = V _{SUP} , V _{SUP} = 27 V, LIN = 0 V; Figure 16	-1		1	mA
I _{BUS_NO_GND}	Leakage current, loss of ground (ISO/DIS 17987 Param 15,60)	GND = V _{SUP} , V _{SUP} ≥ 36 V, LIN = 0 V; Figure 16	-1.5		1.5	mA
I _{BUS_NO_BAT}	Leakage current, loss of supply (ISO/DIS 17987 Param , 61)	LIN = 48 V, V _{SUP} = GND; Figure 17			5	μA
V _{BUSdom}	Low level input voltage (ISO/DIS 17987 Param , 62)	LIN dominant (including LIN dominant for wake up) Figure 11 , Figure 10			0.4 x V _{SUP}	V
V _{BUSrec}	High level input voltage (ISO/DIS 17987 Param , 63)	Lin recessive Figure 11 , Figure 10	0.6 x V _{SUP}			V
V _{BUS_CNT}	Receiver center threshold (ISO/DIS 17987 Param , 64)	V _{BUS_CNT} = (V _{IL} + V _{IH})/2 Figure 11 , Figure 10	0.475 x V _{SUP}	0.5 x V _{SUP}	0.525 x V _{SUP}	V
V _{HYS}	Hysteresis voltage (ISO/DIS 17987 Param , 65)	V _{HYS} = (V _{IL} - V _{IH}) Figure 11 , Figure 10			0.175 x V _{SUP}	V
V _{SERIAL_DIODE}	Serial diode LIN term pull-up path (ISO/DIS 17987 Parameters , 66)		0.4	0.7	1.0	V
R _{SLAVE}	Pull-up resistor to V _{SUP} (ISO/DIS 17987 Parameters , 71)	Normal and Standby modes	20	45	60	kΩ
I _{RSLEEP}	Pull-up current source to V _{SUP}	Sleep mode, V _{SUP} = 27 V, LIN = GND	-2		-20	μA
C _{LIN_PIN}	Capacitance of the LIN pin				45	pF
EN INPUT PIN						
V _{IL}	Low level input voltage		-0.3		0.8	V
V _{IH}	High level input voltage		2		5.5	V
V _{HYS}	Hysteresis voltage	By design and characterization		50	500	
I _{IL}	Low level input current	EN = Low	-5	0	5	μA
R _{EN}	Internal pull-down resistor		125	350	800	kΩ
AC Characteristics						
D _{112V}	Duty Cycle 1 (ISO/DIS 17987 Param 27)	TH _{REC(MAX)} = 0.744 x V _{SUP} , TH _{DOM(MAX)} = 0.581 x V _{SUP} , V _{SUP} = 7 V to 18 V, t _{BIT} = 50 μs (20 kbps), D1 = t _{BUS_rec(min)} /(2 x t _{BIT}) (See Figure 18 , Figure 19)	0.396			

Electrical Characteristics (continued)

over operating free-air temperature range (unless otherwise noted)

PARAMETER		TEST CONDITIONS	MIN	TYP	MAX	UNIT
D1 _{12V}	Duty Cycle 1	$TH_{REC(MAX)} = 0.625 \times V_{SUP}$, $TH_{DOM(MAX)} = 0.581 \times V_{SUP}$, $V_{SUP} = 4\text{ V to }7\text{ V}$, $t_{BIT} = 50\ \mu\text{s}$ (20 kbps), $D1 = t_{BUS_rec(min)}/(2 \times t_{BIT})$ (See Figure 18 , Figure 19)	0.396			
D2 _{12V}	Duty Cycle 2 (ISO/DIS 17987 Param 28)	$TH_{REC(MIN)} = 0.422 \times V_{SUP}$, $TH_{DOM(MIN)} = 0.284 \times V_{SUP}$, V_{SUP} $= 4.6\text{ V to }18\text{ V}$, $t_{BIT} = 50\ \mu\text{s}$ (20 kbps), $D2 =$ $t_{BUS_rec(MAX)}/(2 \times t_{BIT})$ (See Figure 18 , Figure 19)			0.581	
D3 _{12V}	Duty Cycle 3 (ISO/DIS 17987 Param 29)	$TH_{REC(MAX)} = 0.778 \times V_{SUP}$, $TH_{DOM(MAX)} = 0.616 \times V_{SUP}$, $V_{SUP} = 7\text{ V to }18\text{ V}$, $t_{BIT} = 96\ \mu\text{s}$ (10.4 kbps), $D3 = t_{BUS_rec(min)}/(2 \times t_{BIT})$ (See Figure 18 , Figure 19)	0.417			
D3 _{12V}	Duty Cycle	$TH_{REC(MAX)} = 0.645 \times V_{SUP}$, $TH_{DOM(MAX)} = 0.616 \times V_{SUP}$, $V_{SUP} = 4\text{ V to }7\text{ V}$, $t_{BIT} = 96\ \mu\text{s}$ (10.4 kbps), $D3 = t_{BUS_rec(min)}/(2 \times t_{BIT})$ (See Figure 18 , Figure 19)	0.417			
D4 _{12V}	Duty Cycle 4 (ISO/DIS 17987 Param 30)	$TH_{REC(MIN)} = 0.389 \times V_{SUP}$, $TH_{DOM(MIN)} = 0.251 \times V_{SUP}$, $V_{SUP} = 4.6\text{ V to }18\text{ V}$, $t_{BIT} = 96\ \mu\text{s}$ (10.4 kbps), $D4 = t_{BUS_rec(MAX)}/(2 \times t_{BIT})$ (See Figure 18 , Figure 19)			0.59	
D1 _{24V}	Duty Cycle 1 (ISO/DIS 17987 Param 72)	$TH_{REC(MAX)} = 0.710 \times V_{SUP}$, $TH_{DOM(MAX)} = 0.554 \times V_{SUP}$, V_{SUP} $= 15\text{ V to }36\text{ V}$, $t_{BIT} = 50\ \mu\text{s}$, $D1 =$ $t_{BUS_rec(min)}/(2 \times t_{BIT})$ (See Figure 18 , Figure 19)	0.330			
D2 _{24V}	Duty Cycle 2 (ISO/DIS 17987 Param 73)	$TH_{REC(MIN)} = 0.446 \times V_{SUP}$, $TH_{DOM(MIN)} = 0.302 \times V_{SUP}$, V_{SUP} $= 15.6\text{ V to }36\text{ V}$, $t_{BIT} = 50\ \mu\text{s}$, $D2 =$ $t_{BUS_rec(MAX)}/(2 \times t_{BIT})$ (See Figure 18 , Figure 19)			0.642	
D3 _{24V}	Duty Cycle 3 (ISO/DIS 17987 Param 74)	$TH_{REC(MAX)} = 0.744 \times V_{SUP}$, $TH_{DOM(MAX)} = 0.581 \times V_{SUP}$, V_{SUP} $= 7\text{ V to }36\text{ V}$, $t_{BIT} = 96\ \mu\text{s}$, $D3 =$ $t_{BUS_rec(min)}/(2 \times t_{BIT})$ (See Figure 18 , Figure 19)	0.386			
D3 _{24V}	Duty Cycle 3	$TH_{REC(MAX)} = 0.645 \times V_{SUP}$, $TH_{DOM(MAX)} = 0.581 \times V_{SUP}$, V_{SUP} $= 4\text{ V to }7\text{ V}$, $t_{BIT} = 96\ \mu\text{s}$, $D3 =$ $t_{BUS_rec(min)}/(2 \times t_{BIT})$ (See Figure 18 , Figure 19)	0.386			
D4 _{24V}	Duty Cycle 4 (ISO/DIS 17987 Param 75)	$TH_{REC(MIN)} = 0.442 \times V_{SUP}$, $TH_{DOM(MIN)} = 0.284 \times V_{SUP}$, V_{SUP} $= 4.6\text{ V to }36\text{ V}$, $t_{BIT} = 96\ \mu\text{s}$, $D4 =$ $t_{BUS_rec(MAX)}/(2 \times t_{BIT})$ (See Figure 18 , Figure 19)			0.591	

ADVANCE INFORMATION

6.8 AC Switching Characteristics

over operating free-air temperature range (unless otherwise noted)

PARAMETER		TEST CONDITIONS	MIN	TYP	MAX	UNIT
t_{rx_pdr} t_{rx_pdf}	Receiver rising/falling propagation delay time (ISO/DIS 17987 Param , 76)	$R_{RXD} = 2.4\text{ k}\Omega$, $C_{RXD} = 20\text{ pF}$ (See Figure 20 Figure 21 and)			6	μs
t_{rs_sym}	Symmetry of receiver propagation delay time Receiver rising propagation delay time (ISO/DIS 17987 Param , 77)	Rising edge with respect to falling edge, ($t_{rx_sym} = t_{rx_pdf} - t_{rx_pdr}$), $R_{RXD} = 2.4\text{ k}\Omega$, $C_{RXD} = 20\text{ pF}$ (Figure 20 Figure 21 and)	-2		2	μs
t_{LINBUS}	LIN wakeup time (Minimum dominant time on LIN bus for wakeup)	See Figure 24 , Figure 27 , and Figure 28	25	65	150	μs
t_{CLEAR}	Time to clear false wakeup prevention logic if LIN bus had a bus stuck dominant fault (recessive time on LIN bus to clear bust stuck dominant fault)	See Figure 28	8	25	50	μs
t_{DST}	Dominant state time out		20	45	80	ms
t_{MODE_CHANGE}	Mode change delay time	Time to change from standby mode to normal mode or normal mode to sleep mode through EN pin: See Figure 22 and Figure 29	2		15	μs
t_{NOMINT}	Normal mode initialization time	Time for normal mode to initialize and data on RXD pin to be valid See Figure 22			35	μs
t_{PWR}	Power up time	Upon power up time it takes for valid data on RXD			1.5	ms

6.9 Typical Characteristics

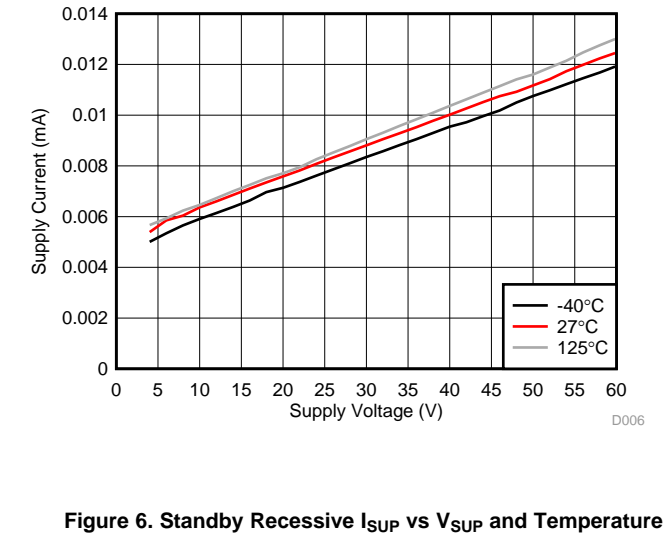
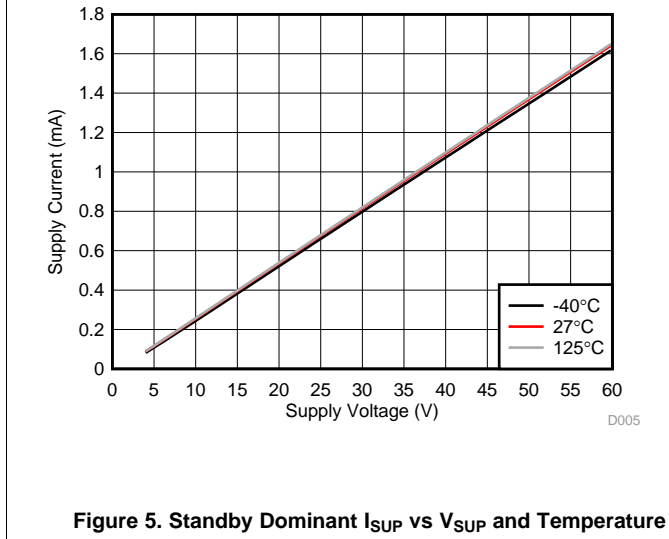
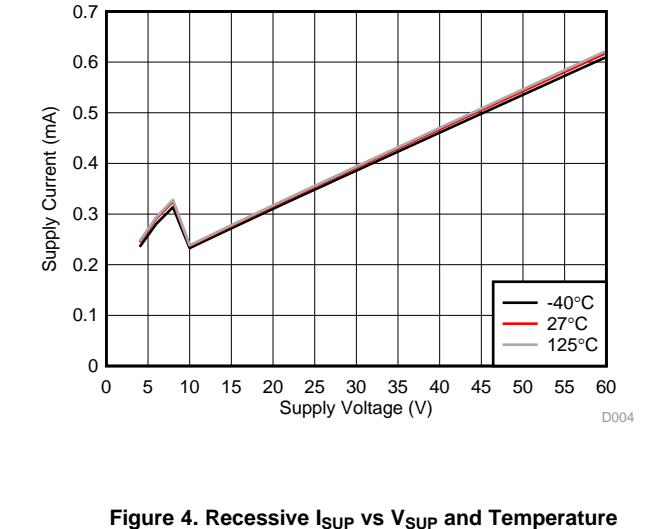
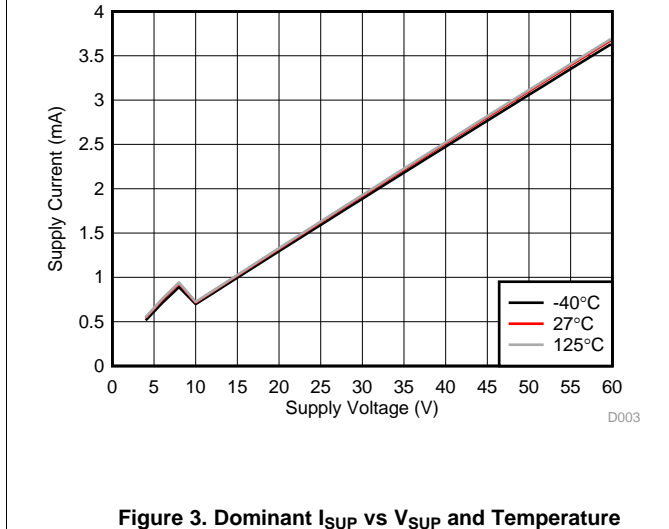
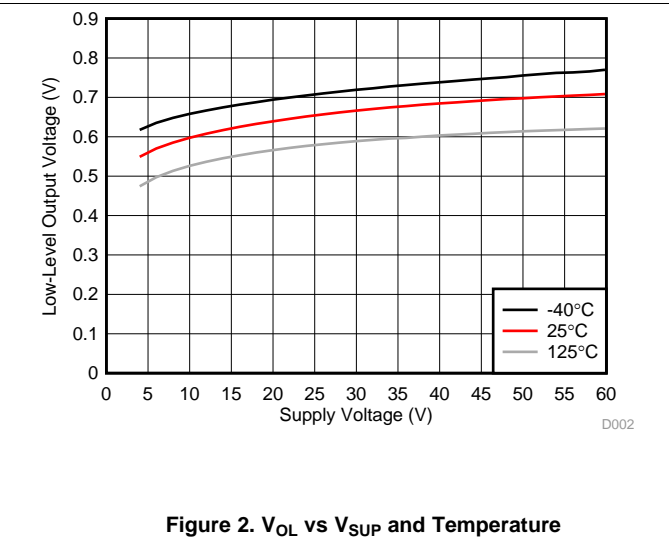
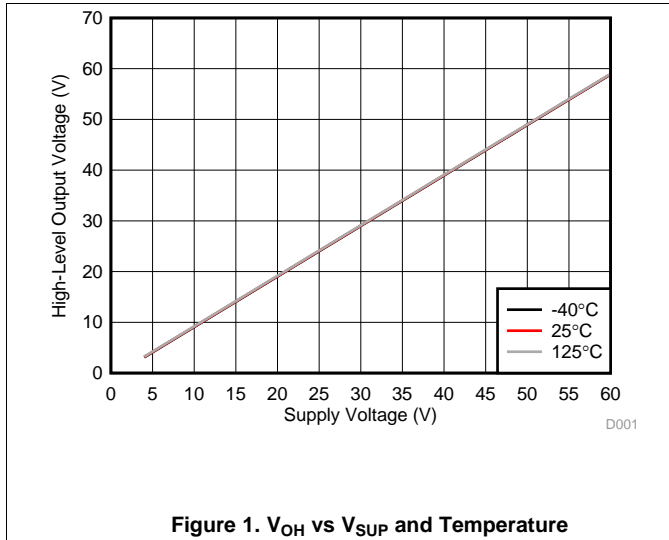

ADVANCE INFORMATION

Typical Characteristics (continued)

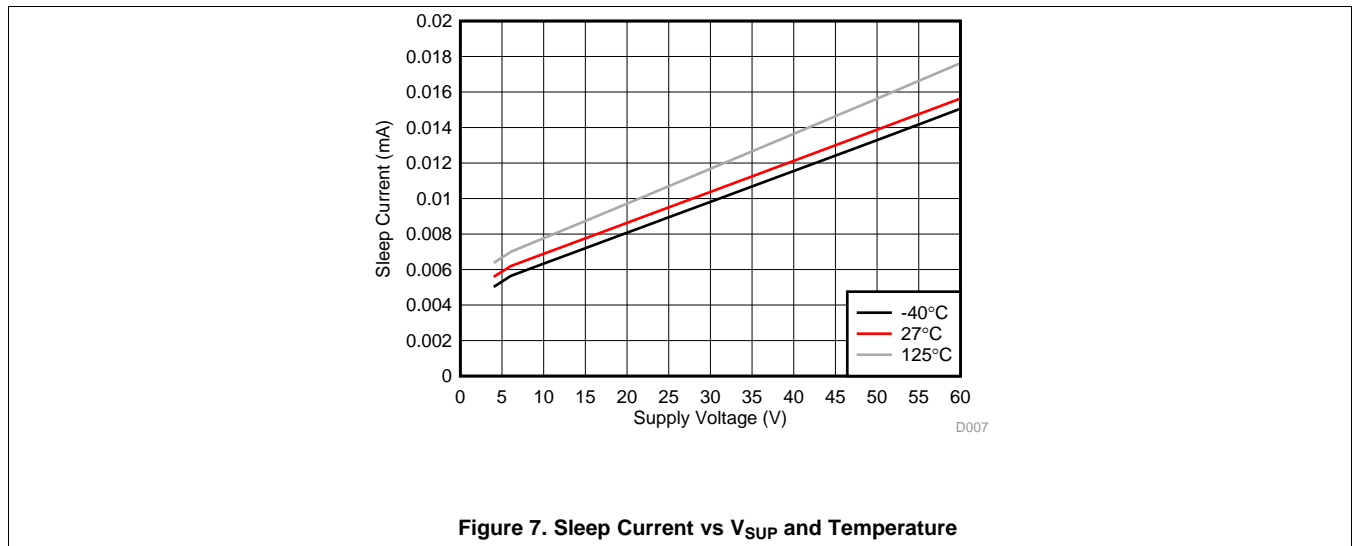
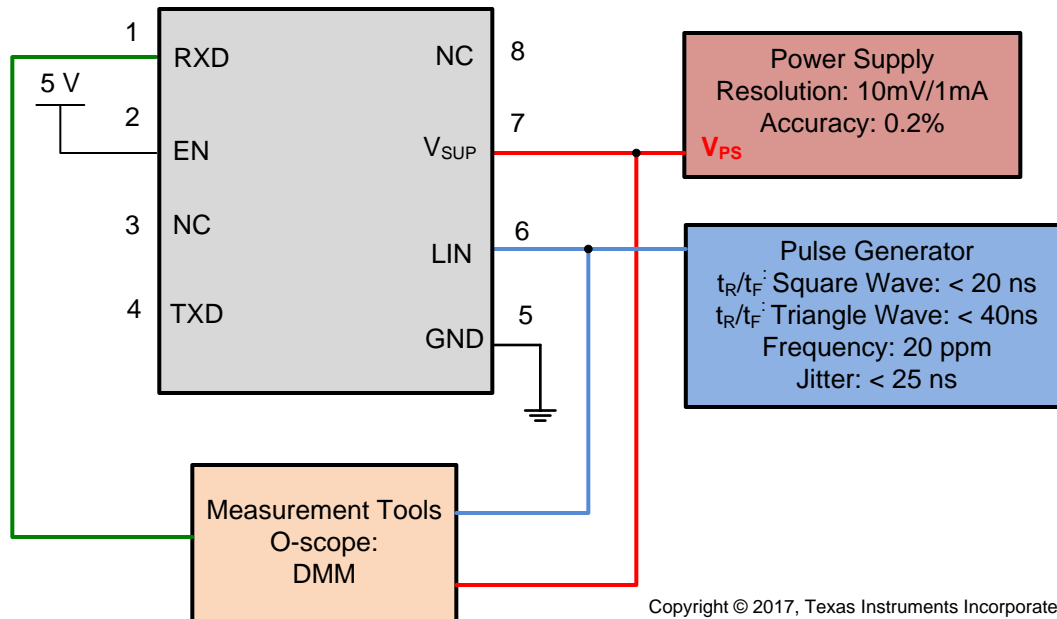

Figure 7. Sleep Current vs V_{SUP} and Temperature

7 Parameter Measurement Information



Copyright © 2017, Texas Instruments Incorporated

Figure 8. Test System: Operating Voltage Range with RX and TX Access: Parameters 9, 10

ADVANCE INFORMATION

Parameter Measurement Information (continued)

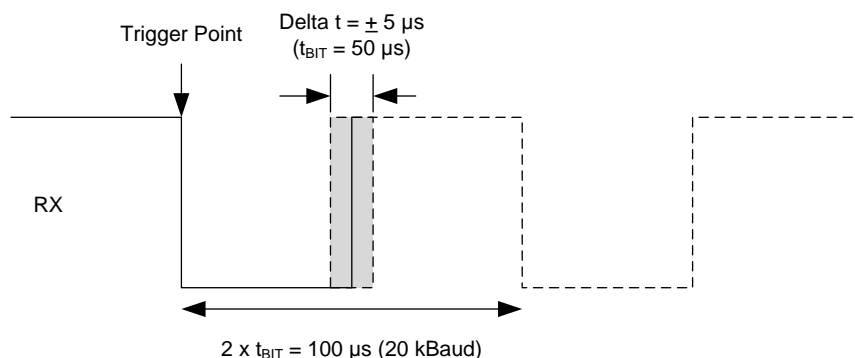

Figure 9. RX Response: Operating Voltage Range

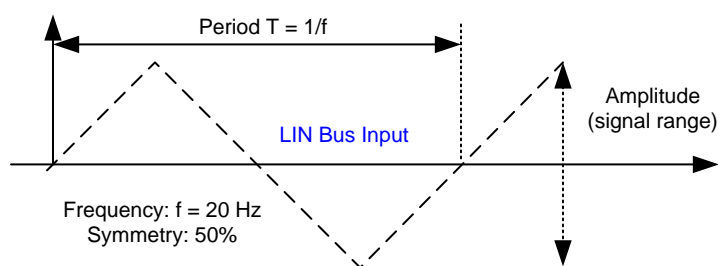

Figure 10. LIN Bus Input Signal

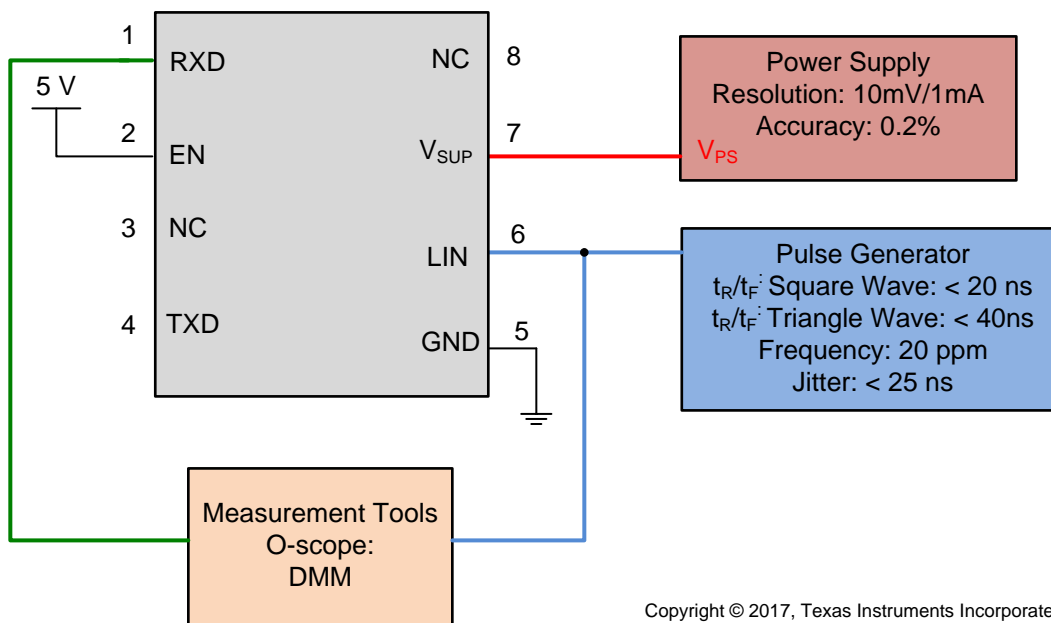
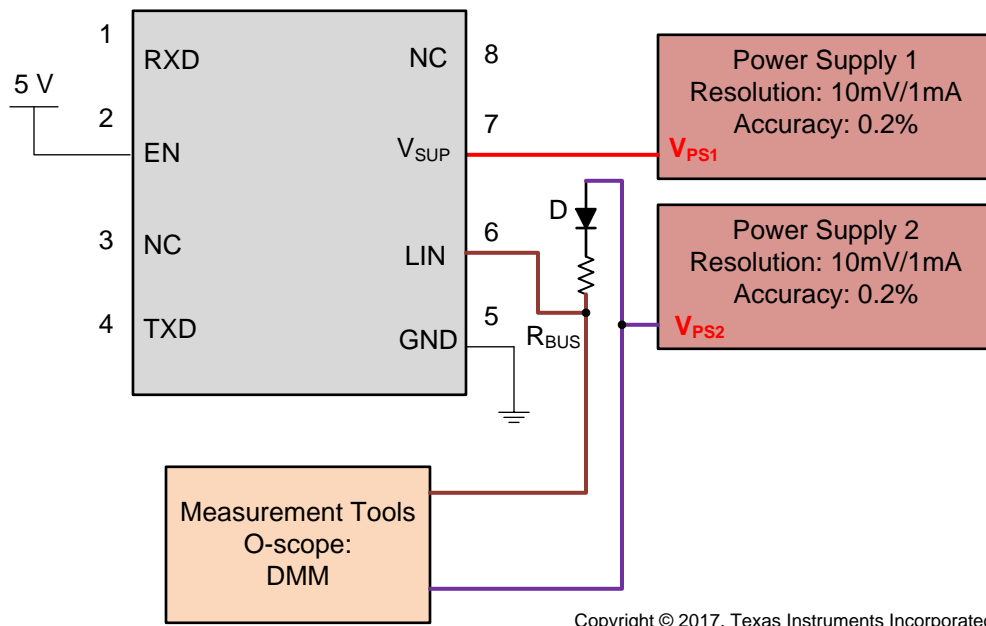

Figure 11. LIN Receiver Test with RX access Param 17, 18, 19, 20

ADVANCE INFORMATION

Parameter Measurement Information (continued)



Copyright © 2017, Texas Instruments Incorporated

Figure 12. V_{SUP_NON_OP} Param 1154/56

ADVANCE INFORMATION

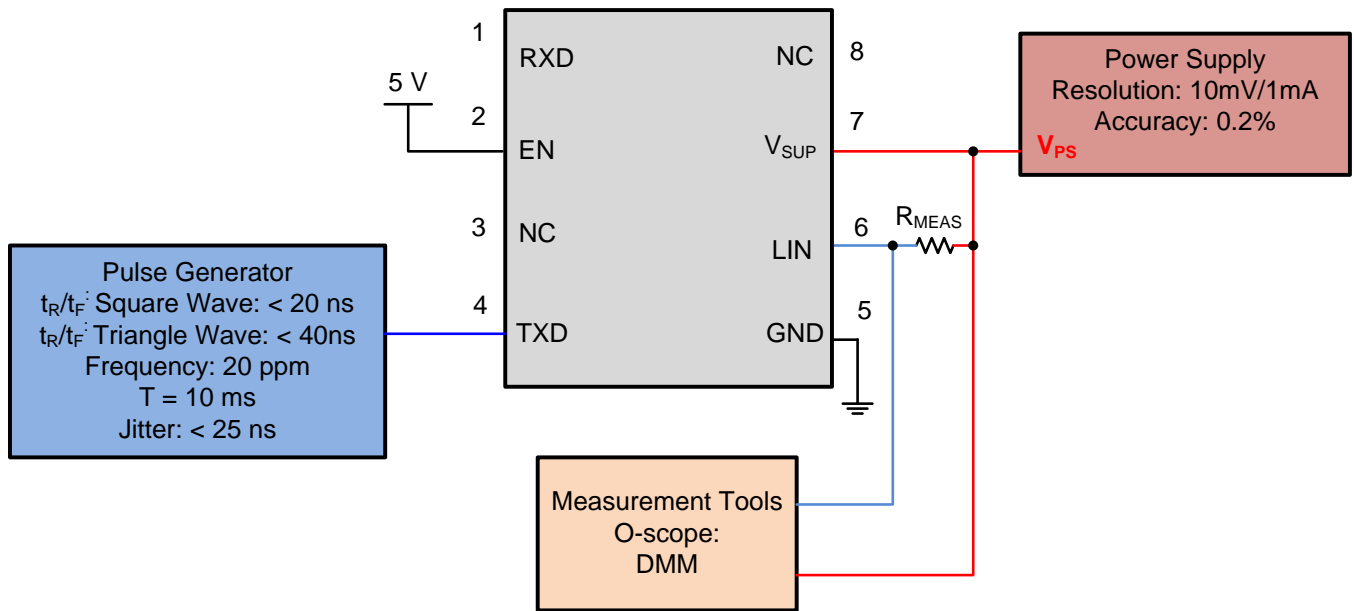

Copyright © 2017, Texas Instruments Incorporated

Figure 13. Test Circuit for I_{BUS_LIM} at Dominant State (Driver on) Param 12

Parameter Measurement Information (continued)

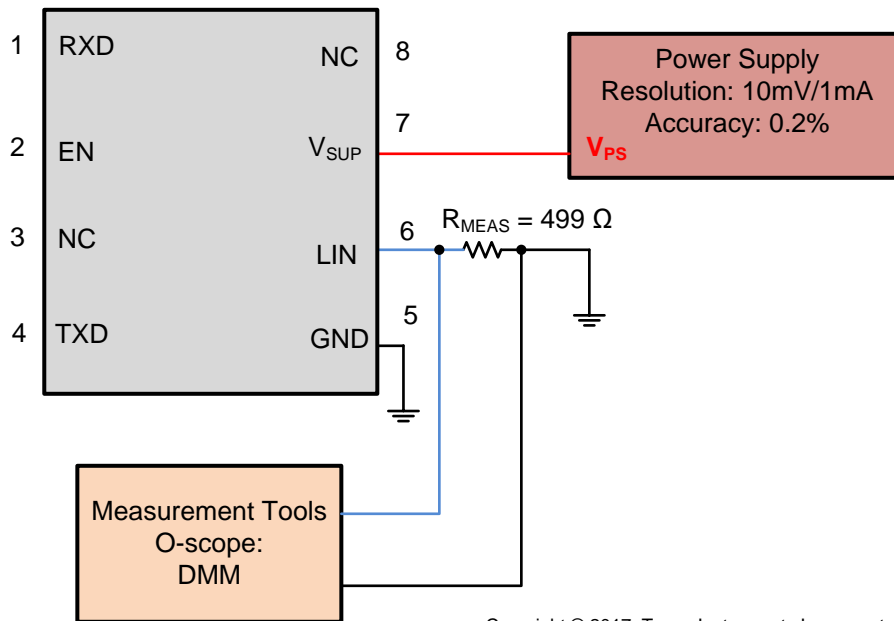

Copyright © 2017, Texas Instruments Incorporated

Figure 14. Test Circuit for $I_{BUS_PAS_dom}$; TXD = Recessive State $V_{BUS} = 0 V$, Param 13

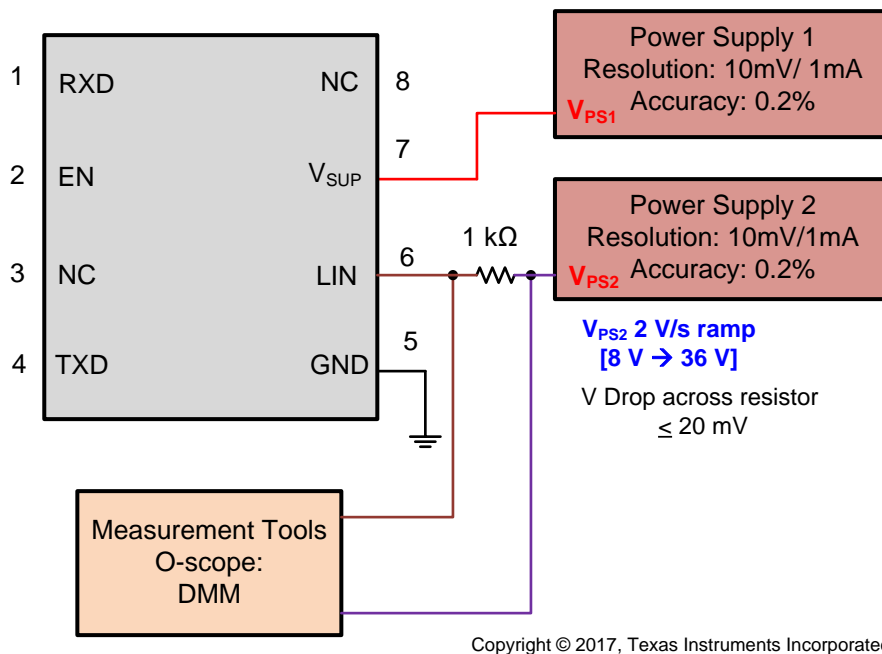

Copyright © 2017, Texas Instruments Incorporated

Figure 15. Test Circuit for $I_{BUS_PAS_rec}$ Param 14

Parameter Measurement Information (continued)

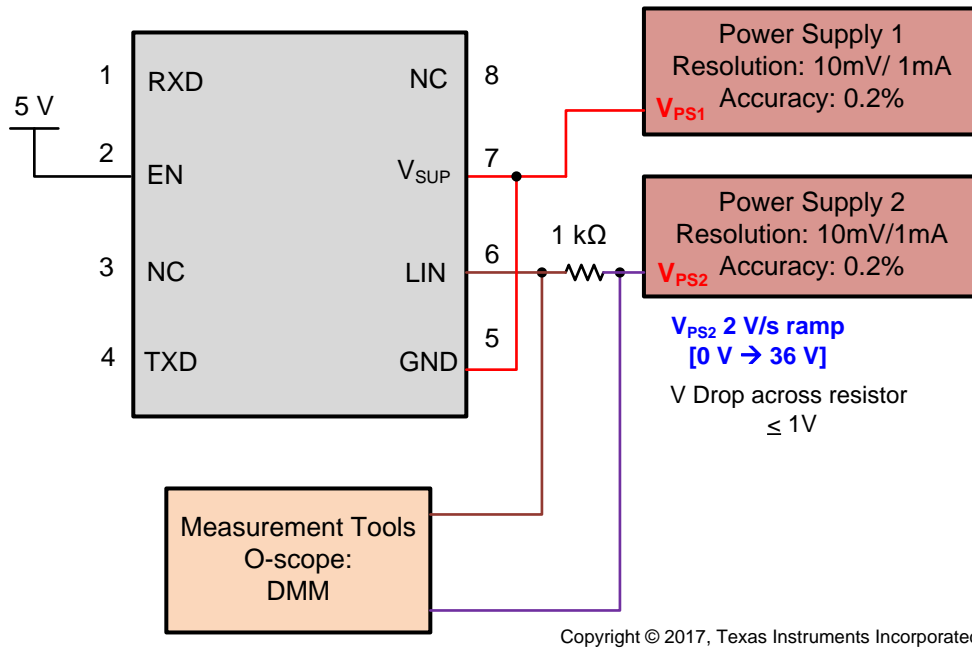

Figure 16. Test Circuit for $I_{BUS_NO_GND}$ Loss of GND

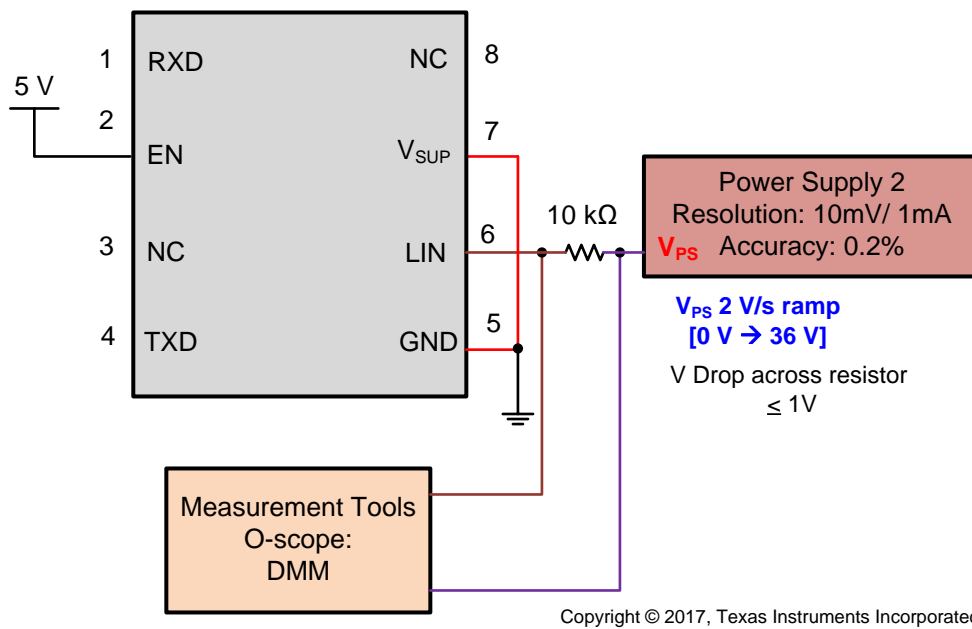

Figure 17. Test Circuit for $I_{BUS_NO_BAT}$ Loss of Battery

Parameter Measurement Information (continued)

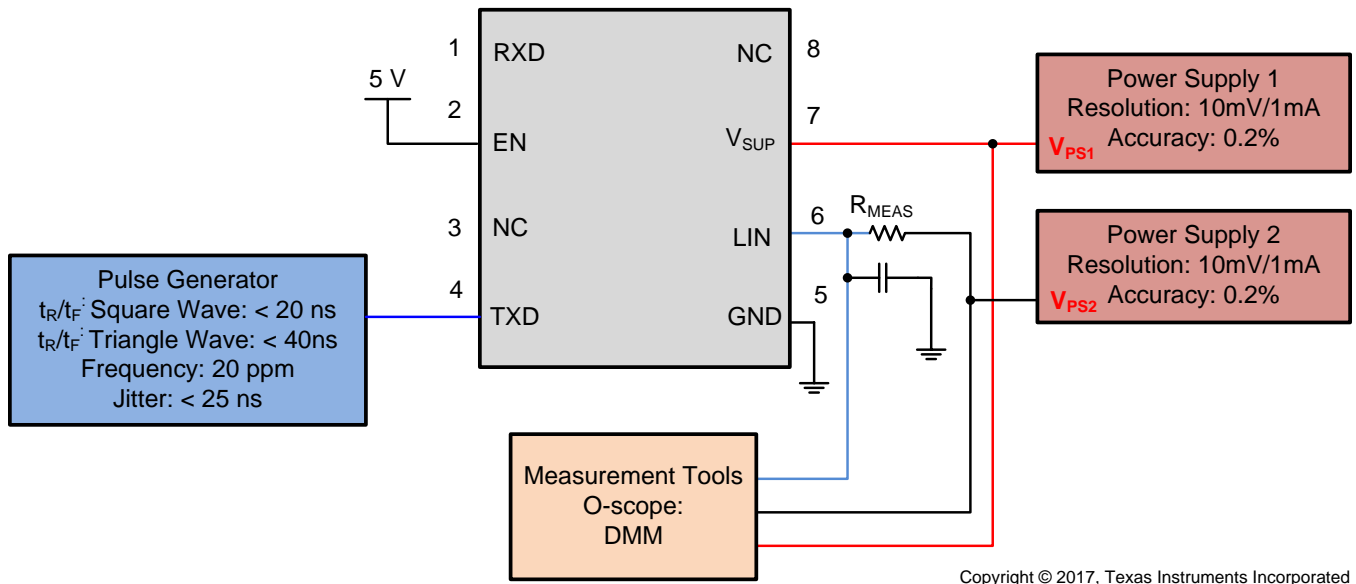

Figure 18. Test Circuit Slope Control and Duty Cycle Param 27, 28, 29, 30, 72, 73, 74, 75

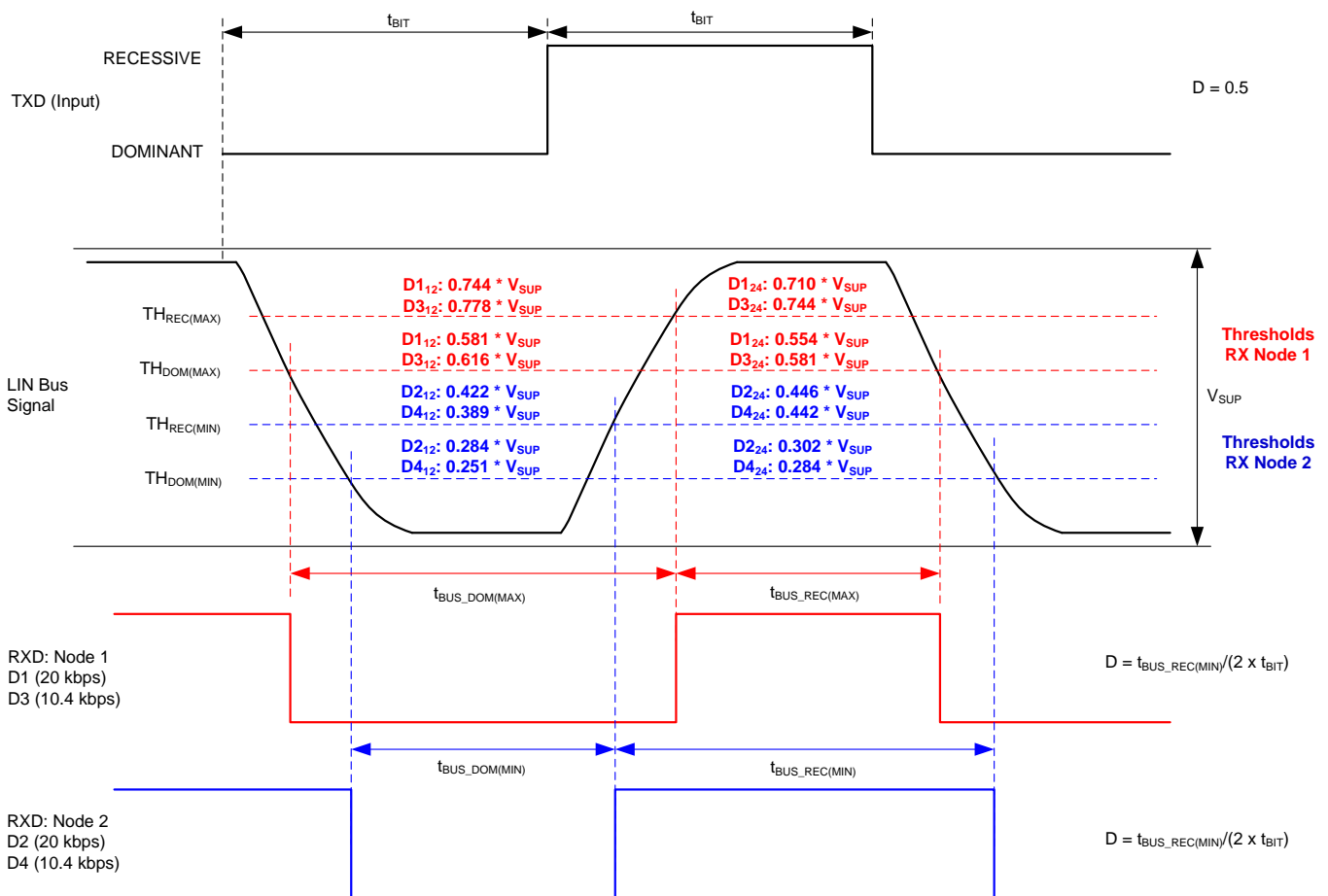

Figure 19. Definition of Bus Timing Parameters

ADVANCE INFORMATION

Parameter Measurement Information (continued)

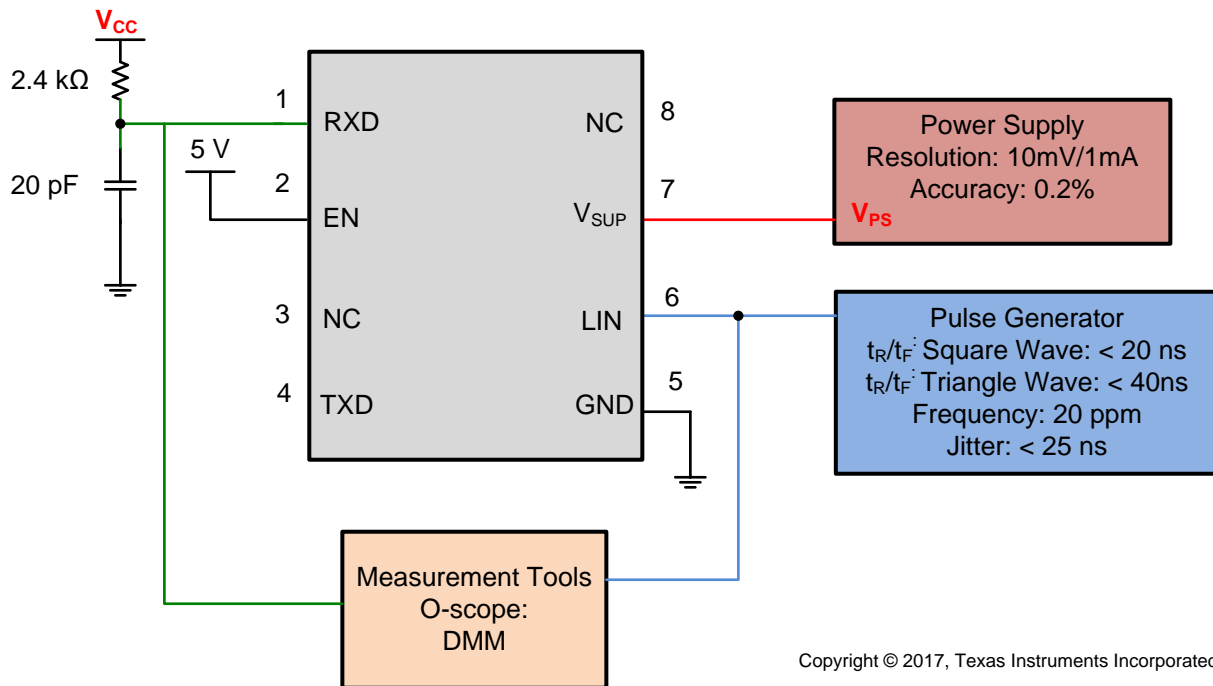

Figure 20. Propagation Delay Test Circuit; Param 31, 32

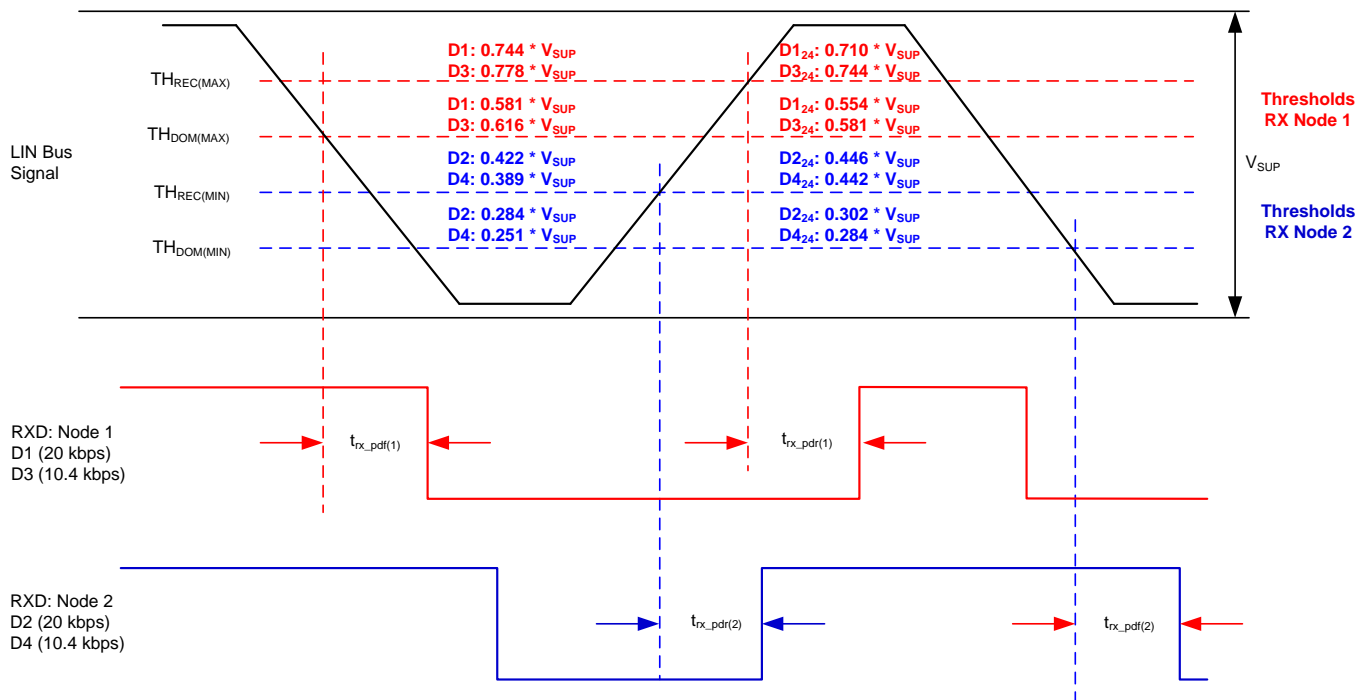

Figure 21. Propagation Delay

Parameter Measurement Information (continued)

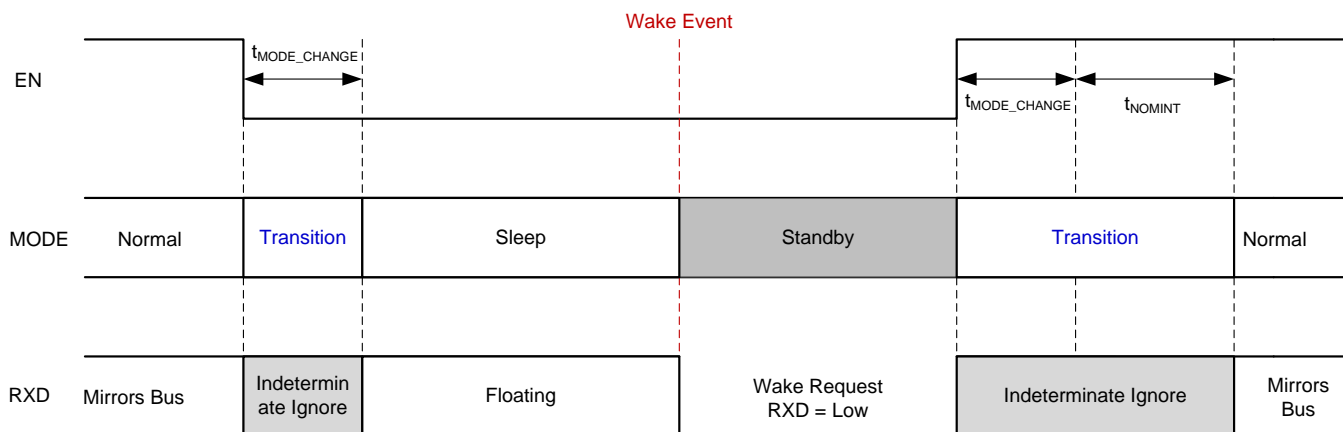

Figure 22. Mode Transitions

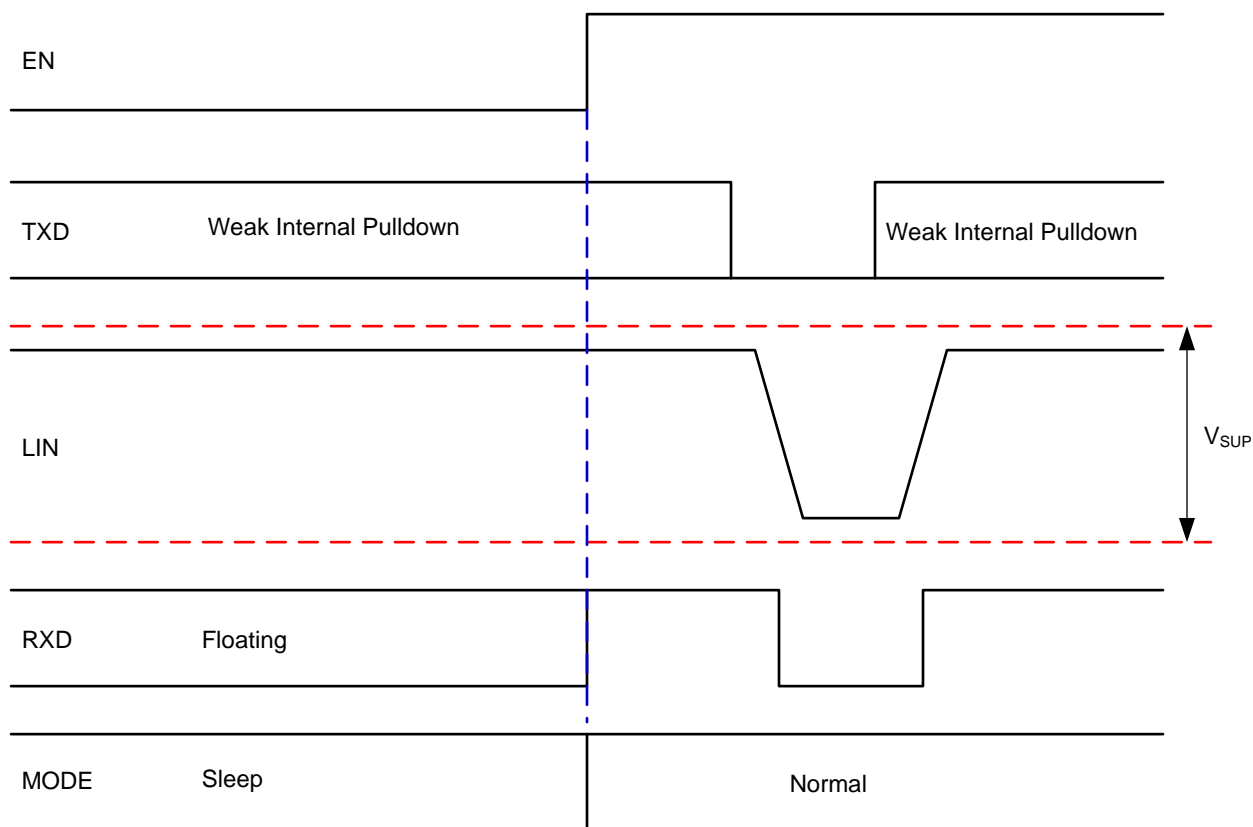

Figure 23. Wakeup Through EN

ADVANCE INFORMATION

Parameter Measurement Information (continued)

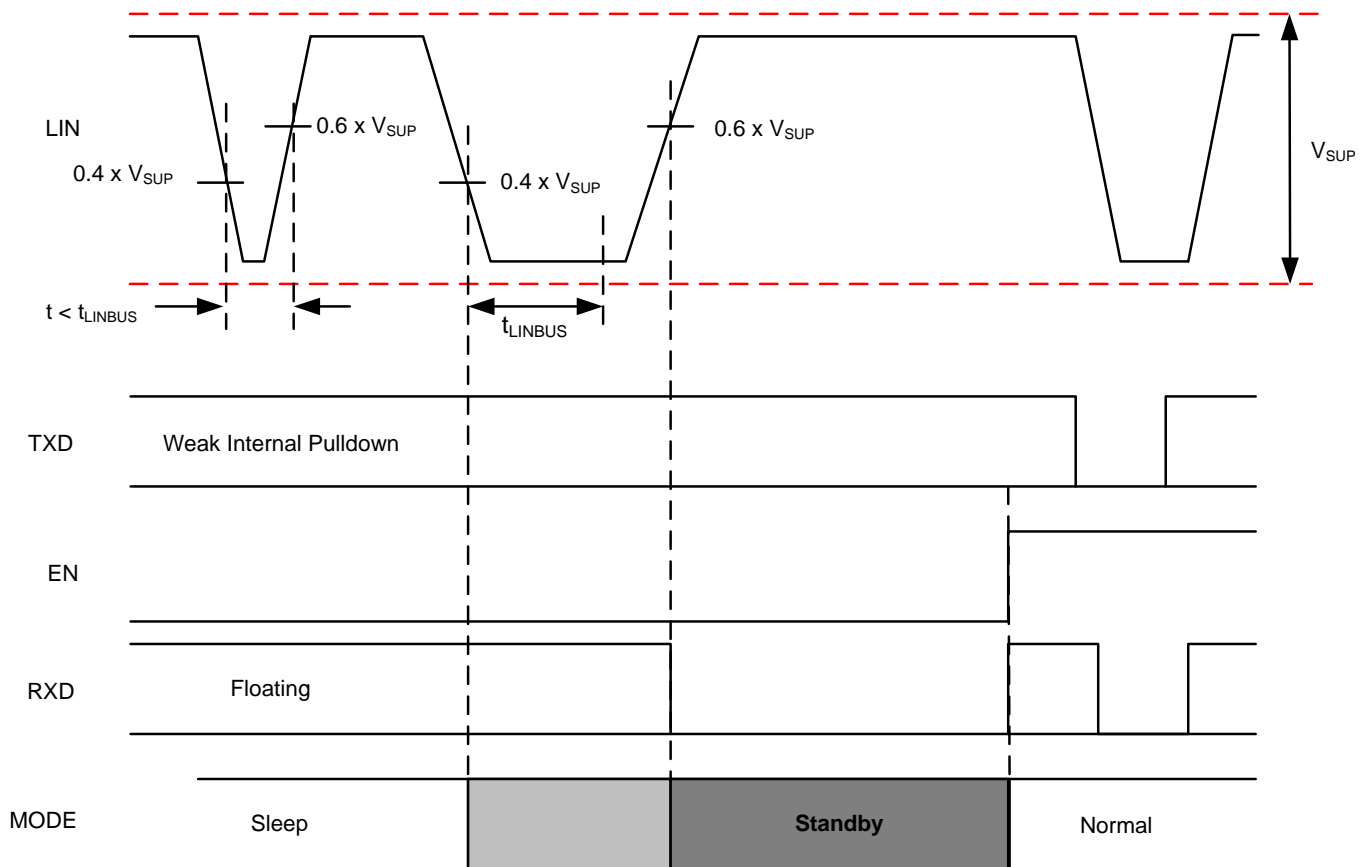
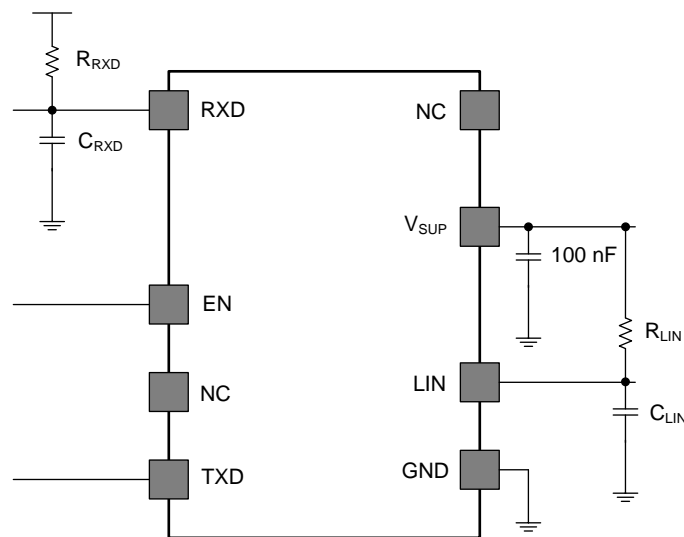

Figure 24. Wakeup through LIN



Copyright © 2017, Texas Instruments Incorporated

Figure 25. Test Circuit for AC Characteristics

8 Detailed Description

8.1 Overview

The TLIN2029-Q1 is a Local Interconnect Network (LIN) physical layer transceiver, compliant to LIN 2.0, LIN 2.1, LIN 2.2, LIN 2.2A, ISO/DIS 17987–4.2 and IBEE Zwickau standards, with integrated wake-up and protection features. The LIN bus is a single wire bidirectional bus typically used for low speed in-vehicle networks using data rates from 2.4 kbps to 20 kbps. The TLIN2029-Q1 LIN receiver works up to 100 kbps supporting in-line programming. The LIN protocol data stream on the TXD input is converted by the TLIN2029-Q1 into a LIN bus signal using a current-limited wave-shaping driver as outlined by the LIN physical layer specification. The receiver converts the data stream to logic level signals that are sent to the microprocessor through the open-drain RXD pin. The LIN bus has two states: dominant state (voltage near ground) and recessive state (voltage near battery). In the recessive state, the LIN bus is pulled high by the internal pull-up resistor (45 kΩ) and a series diode. No external pull-up components are required for slave applications. Master applications require an external pull-up resistor (1 kΩ) plus a series diode per the LIN specification. The TLIN2029-Q1 provides many protection features such as immunity to ESD and high bus standoff voltage. The device also provides two methods to wake up: EN pin and from the LIN bus.

8.2 Functional Block Diagram

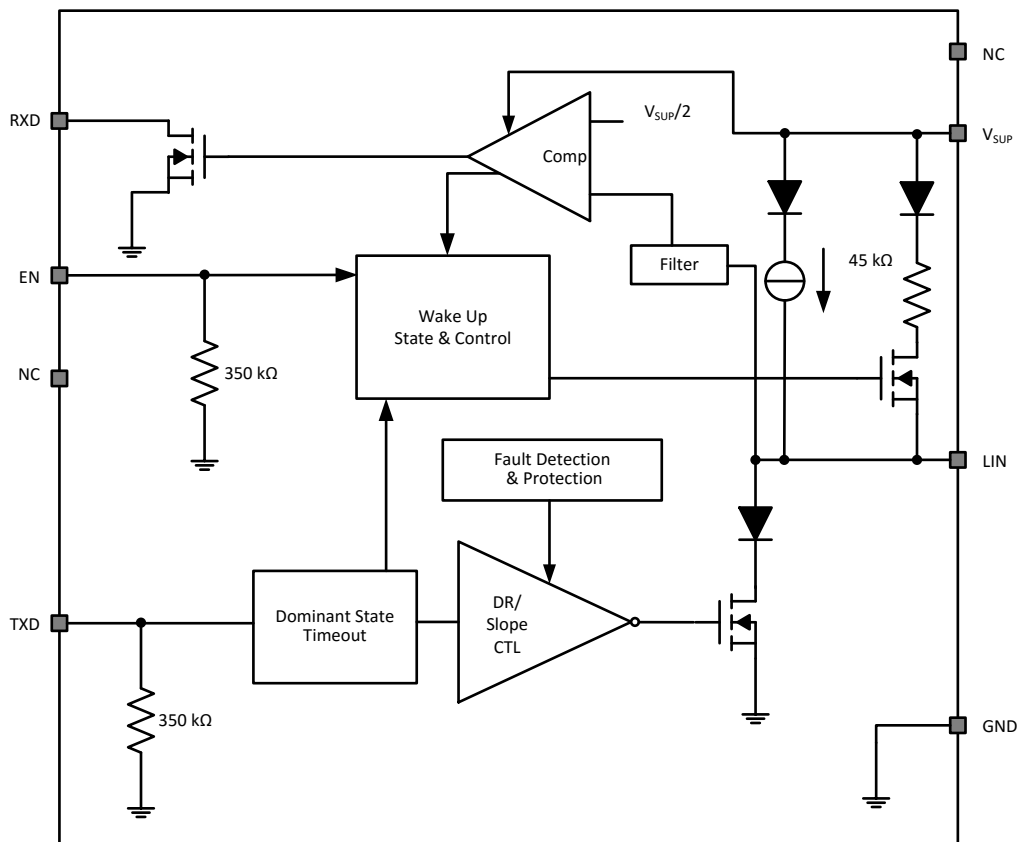

Copyright © 2017, Texas Instruments Incorporated

8.3 Feature Description

8.3.1 LIN (Local Interconnect Network) Bus

This high voltage input/output pin is a single wire LIN bus transmitter and receiver. The LIN pin can survive transient voltages up to 60 V. Reverse currents from the LIN to supply (V_{SUP}) are minimized with blocking diodes, even in the event of a ground shift or loss of supply (V_{SUP}).

Feature Description (continued)

8.3.1.1 LIN Transmitter Characteristics

The transmitter has thresholds and AC parameters according to the LIN specification. The transmitter is a low side transistor with internal current limitation and thermal shutdown. During a thermal shut-down condition, the transmitter is disabled to protect the device. There is an internal pull-up resistor with a serial diode structure to V_{SUP} , so no external pull-up components are required for the LIN slave mode applications. An external pull-up resistor and series diode to V_{SUP} must be added when the device is used for a master node application.

8.3.1.2 LIN Receiver Characteristics

The receiver's characteristic thresholds are proportional to the device supply pin in accordance to the LIN specification.

The receiver is capable of receiving higher data rates (> 100 kbps) than supported by LIN or SAEJ2602 specifications. This allows the TLIN2029-Q1 to be used for high speed downloads at the end-of-line production or other applications. The actual data rate achievable depends on system time constants (bus capacitance and pullup resistance) and driver characteristics used in the system.

8.3.1.2.1 Termination

There is an internal pull-up resistor with a serial diode structure to V_{SUP} , so no external pull-up components are required for the LIN slave mode applications. An external pull-up resistor (1 kΩ) and a series diode to V_{SUP} must be added when the device is used for master node applications as per the LIN specification.

Figure 26 shows a Master Node configuration and how the voltage levels are defined

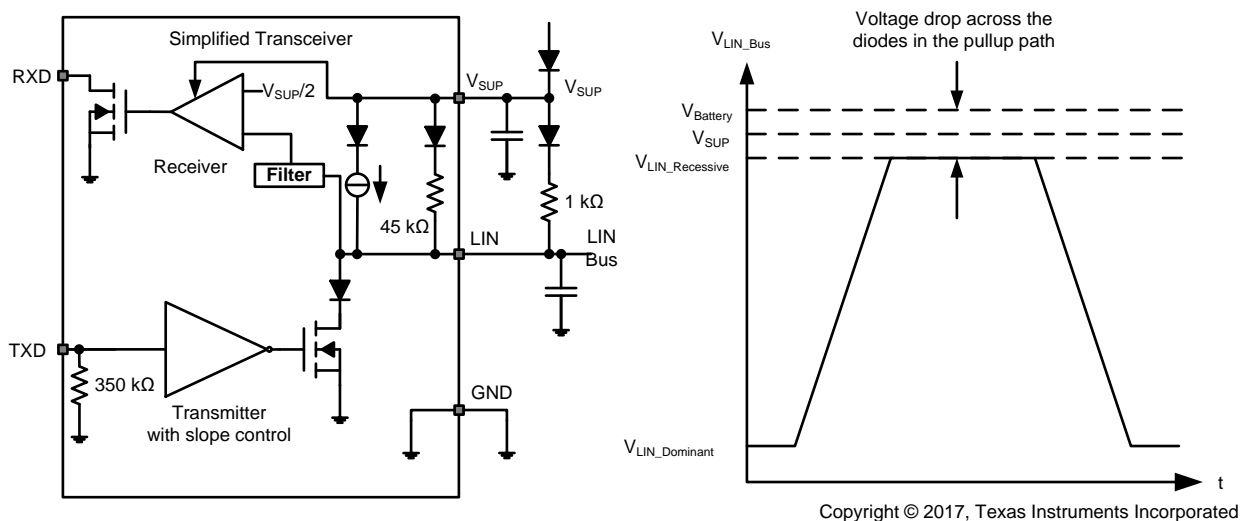

Figure 26. Master Node Configuration with Voltage Levels

8.3.2 TXD (Transmit Input and Output)

TXD is the interface to the MCU's LIN protocol controller or SCI and UART that is used to control the state of the LIN output. When TXD is low the LIN output is dominant (near ground). When TXD is high the LIN output is recessive (near $V_{Battery}$). See Figure 26. The TXD input structure is compatible with microcontrollers with 3.3 V and 5 V I/O. TXD has an internal pull-down resistor. The LIN bus is protected from being stuck dominant through a system failure driving TXD low through the dominant state timer-out timer.

Feature Description (continued)

8.3.3 RXD (Receive Output)

RXD is the interface to the MCU's LIN protocol controller or SCI and UART, which reports the state of the LIN bus voltage. LIN recessive (near V_{Battery}) is represented by a high level on the RXD and LIN dominant (near ground) is represented by a low level on the RXD pin. The RXD output structure is an open-drain output stage. This allows the device to be used with 3.3 V and 5 V I/O microcontrollers. If the microcontroller's RXD pin does not have an integrated pullup, an external pullup resistor to the microcontroller I/O supply voltage is required. In standby mode the RXD pin is driven low to indicate a wake up request from the LIN bus.

8.3.4 V_{SUP} (Supply Voltage)

V_{SUP} is the power supply pin. V_{SUP} is connected to the battery through an external reverse-blocking diode (Figure 26). If there is a loss of power at the ECU level, the device has extremely low leakage from the LIN pin, which does not load the bus down. This is optimal for LIN systems in which some of the nodes are unpowered (ignition supplied) while the rest of the network remains powered (battery supplied).

8.3.5 GND (Ground)

GND is the device ground connection. The device can operate with a ground shift as long as the ground shift does not reduce the V_{SUP} below the minimum operating voltage. If there is a loss of ground at the ECU level, the device has extremely low leakage from the LIN pin, which does not load the bus down. This is optimal for LIN systems in which some of the nodes are unpowered (ignition supplied) while the rest of the network remains powered (battery supplied).

8.3.6 EN (Enable Input)

EN controls the operational modes of the device. When EN is high the device is in normal operating mode allowing a transmission path from TXD to LIN and from LIN to RXD. When EN is low the device is put into sleep mode and there are no transmission paths available. The device can enter normal mode only after wake up. EN has an internal pull-down resistor to ensure the device remains in low power mode even if EN floats.

8.3.7 Protection Features

The TLIN2029-Q1 has several protection features that will now be described.

8.3.8 TXD Dominant Time Out (DTO)

During normal mode, if TXD is inadvertently driven permanently low by a hardware or software application failure, the LIN bus is protected by the dominant state timeout timer. This timer is triggered by a falling edge on the TXD pin. If the low signal remains on TXD for longer than t_{DST} , the transmitter is disabled, thus allowing the LIN bus to return to recessive state and communication to resume on the bus. The protection is cleared and the t_{DST} timer is reset by a rising edge on TXD. The TXD pin has an internal pull-down to ensure the device fails to a known state if TXD is disconnected. During this fault, the transceiver remains in normal mode (assuming no change of stated request on EN), the transmitter is disabled, the RXD pin reflects the LIN bus and the LIN bus pull-up termination remains on.

8.3.9 Bus Stuck Dominant System Fault: False Wake Up Lockout

The TLIN2029-Q1 contains logic to detect bus stuck dominant system faults and prevents the device from waking up falsely during the system fault. Upon entering sleep mode, the device detects the state of the LIN bus. If the bus is dominant, the wake up logic is locked out until a valid recessive on the bus "clears" the bus stuck dominant, preventing excessive current use. Figure 27 and Figure 28 show the behavior of this protection.

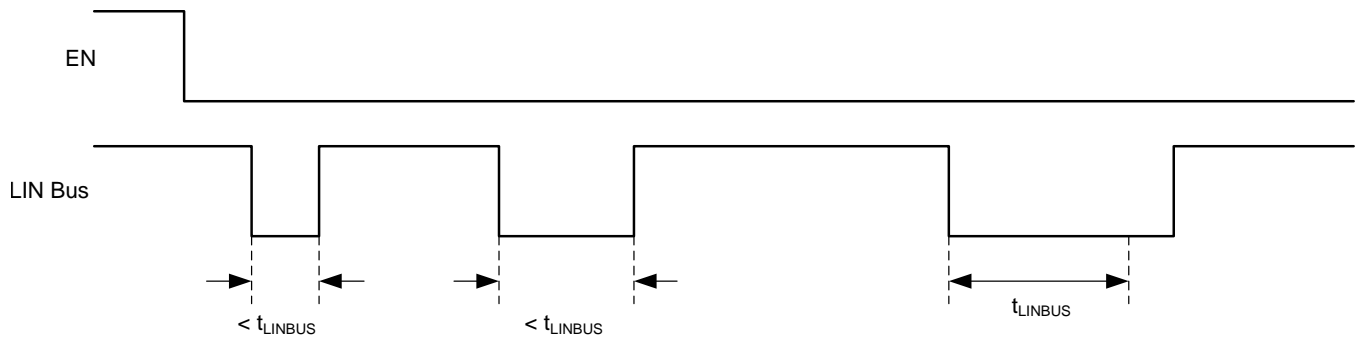
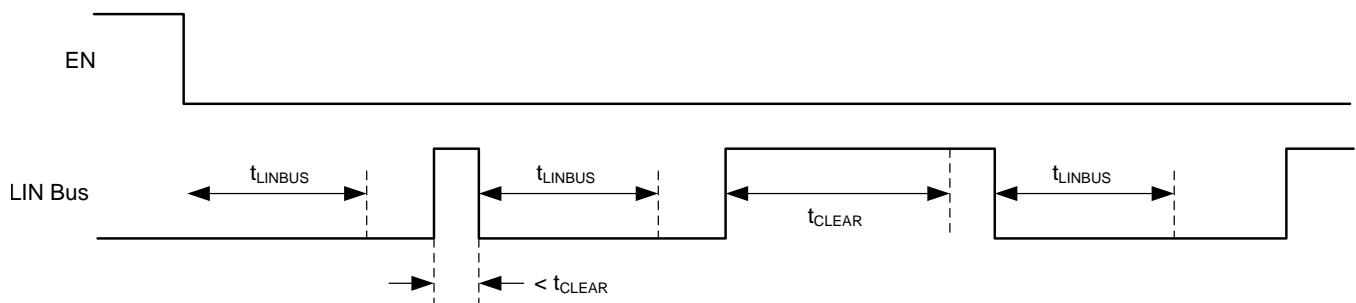
Feature Description (continued)

Figure 27. No Bus Fault: Entering Sleep Mode with Bus Recessive Condition and Wakeup

Figure 28. Bus Fault: Entering Sleep Mode with Bus Stuck Dominant Fault, Clearing, and Wakeup
8.3.10 Thermal Shutdown

The LIN transmitter is protected by limiting the current; however if the junction temperature of the device exceeds the thermal shutdown threshold, the device puts the LIN transmitter into the recessive state. Once the over temperature fault condition has been removed and the junction temperature has cooled beyond the hysteresis temperature, the transmitter is re-enabled, assuming the device remained in the normal operation mode. During this fault, the transceiver remains in normal mode (assuming no change of state request on EN), the transmitter is in recessive state, the RXD pin reflects the LIN bus and LIN bus pullup termination remains on.

8.3.11 Under Voltage on V_{SUP}

The TLIN2029-Q1 contains a power on reset circuit to avoid false bus messages during under voltage conditions when V_{SUP} is less than UV_{SUP} .

8.3.12 Unpowered Device and LIN Bus

In automotive applications some LIN nodes in a system can be unpowered (ignition supplied) while others in the network remains powered by the battery. The TLIN2029-Q1 has extremely low unpowered leakage current from the bus so an unpowered node does not affect the network or load it down.

8.4 Device Functional Modes

The TLIN2029-Q1 has three functional modes of operation: normal, sleep, and standby. The next sections will describe these modes as well as how the device moves between the different modes. Figure 29 graphically shows the relationship while Table 1 shows the state of pins.

Table 1. Operating Modes

MODE	EN	RXD	LIN BUS TERMINATION	TRANSMITTER	COMMENT
Sleep	Low	Floating	Weak Current Pullup	Off	
Standby	Low	Low	45 kΩ (typical)	Off	Wake up event detected, waiting on MCU to set EN
Normal	High	LIN Bus Data	45 kΩ (typical)	On	LIN transmission up to 20 kbps

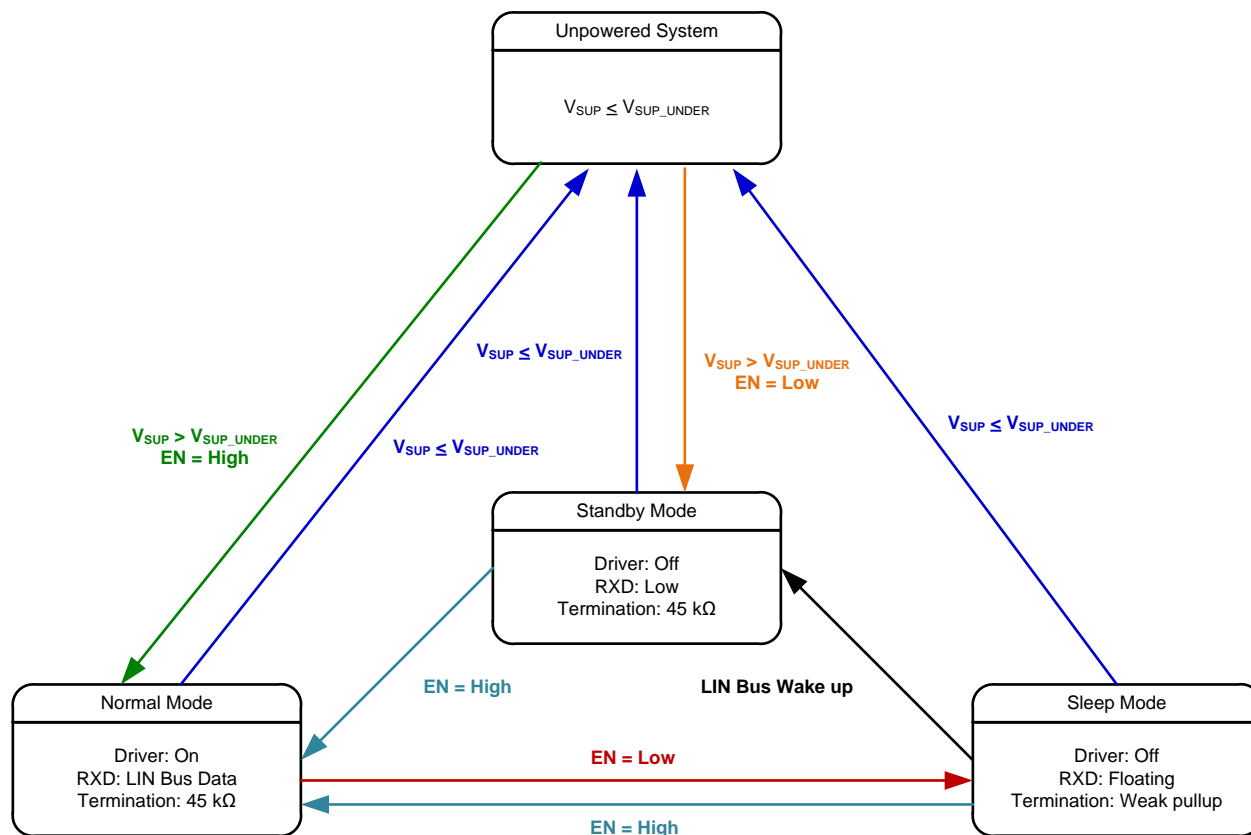

Copyright © 2017, Texas Instruments Incorporated

Figure 29. Operating State Diagram

8.4.1 Normal Mode

If the EN pin is high at power up the device will power up in normal mode and if low will power up in standby mode. The EN pin controls the mode of the device. In normal operational mode the receiver and transmitter are active and the LIN transmission up to the LIN specified maximum of 20 kbps is supported. The receiver detects the data stream on the LIN bus and outputs it on RXD for the LIN controller. A recessive signal on the LIN bus is a logic high and a dominant signal on the LIN bus is a logic low. The driver transmits input data from TXD to the LIN bus. Normal mode is entered as EN transitions high while the TLIN2029-Q1 is in sleep or standby mode for $> t_{MODE_CHANGE}$ plus t_{NOMINT} .

ADVANCE INFORMATION

8.4.2 Sleep Mode

Sleep Mode is the power saving mode for the TLIN2029-Q1. Sleep mode is only entered when the EN pin is low and from normal mode. Even with extremely low current consumption in this mode, the TLIN2029-Q1 can still wake up from LIN bus through a wake up signal or if EN is set high for $> t_{\text{MODE_CHANGE}}$. The LIN bus is filtered to prevent false wake up events. The wake up events must be active for the respective time periods (t_{LINBUS}).

The sleep mode is entered by setting EN low for longer than $t_{\text{MODE_CHANGE}}$.

While the device is in sleep mode, the following conditions exist.

- The LIN bus driver is disabled and the internal LIN bus termination is switched off (to minimize power loss if LIN is short circuited to ground). However, the weak current pull-up is active to prevent false wake up events in case an external connection to the LIN bus is lost.
- The normal receiver is disabled.
- EN input and LIN wake up receiver are active.

8.4.3 Standby Mode

This mode is entered whenever a wake up event occurs through LIN bus while the device is in sleep mode. The LIN bus slave termination circuit is turned on when standby mode is entered. Standby mode is signaled through a low level on RXD. See [Standby Mode Application Note](#) for more application information.

When EN is set high for longer than $t_{\text{MODE_CHANGE}}$ while the device is in standby mode the device returns to normal mode and the normal transmission paths from TXD to LIN bus and LIN bus to RXD are enabled.

8.4.4 Wake Up Events

There are two ways to wake up from sleep mode:

- Remote wake up initiated by the falling edge of a recessive (high) to dominant (low) state transition on LIN bus where the dominant state is held for t_{LINBUS} filter time. After this t_{LINBUS} filter time has been met and a rising edge on the LIN bus going from dominant state to recessive state initiates a remote wake up event, eliminating false wake ups from disturbances on the LIN bus or if the bus is shorted to ground.
- Local wake up through EN being set high for longer than $t_{\text{MODE_CHANGE}}$.

8.4.4.1 Wake Up Request (RXD)

When the TLIN2029-Q1 encounters a wake up event from the LIN bus, RXD goes low and the device transitions to standby mode until EN is reasserted high and the device enters normal mode. Once the device enters normal mode, the RXD pin releases the wake up request signal and the RXD pin then reflects the receiver output from the LIN bus.

8.4.4.2 Mode Transitions

When the TLIN2029-Q1 is transitioning from normal to sleep or standby modes the device needs the time $t_{\text{MODE_CHANGE}}$ to allow the change to fully propagate from the EN pin through the device into the new state. When transitioning from sleep or standby to normal mode the device needs $t_{\text{MODE_CHANGE}}$ plus t_{NOMINT} .

9 Application and Implementation

NOTE

Information in the following applications sections is not part of the TI component specification, and TI does not warrant its accuracy or completeness. TI's customers are responsible for determining suitability of components for their purposes. Customers should validate and test their design implementation to confirm system functionality.

9.1 Application Information

The TLIN2029-Q1 can be used as both a slave device and a master device in a LIN network. The device comes with the ability to support both remote wake up request and local wake up request.

9.2 Typical Application

The device integrates a 45 kΩ pull-up resistor and series diode for slave applications. For master applications an external 1 kΩ pull-up resistor with series blocking diode can be used. shows the device being used in both master and slave applications.

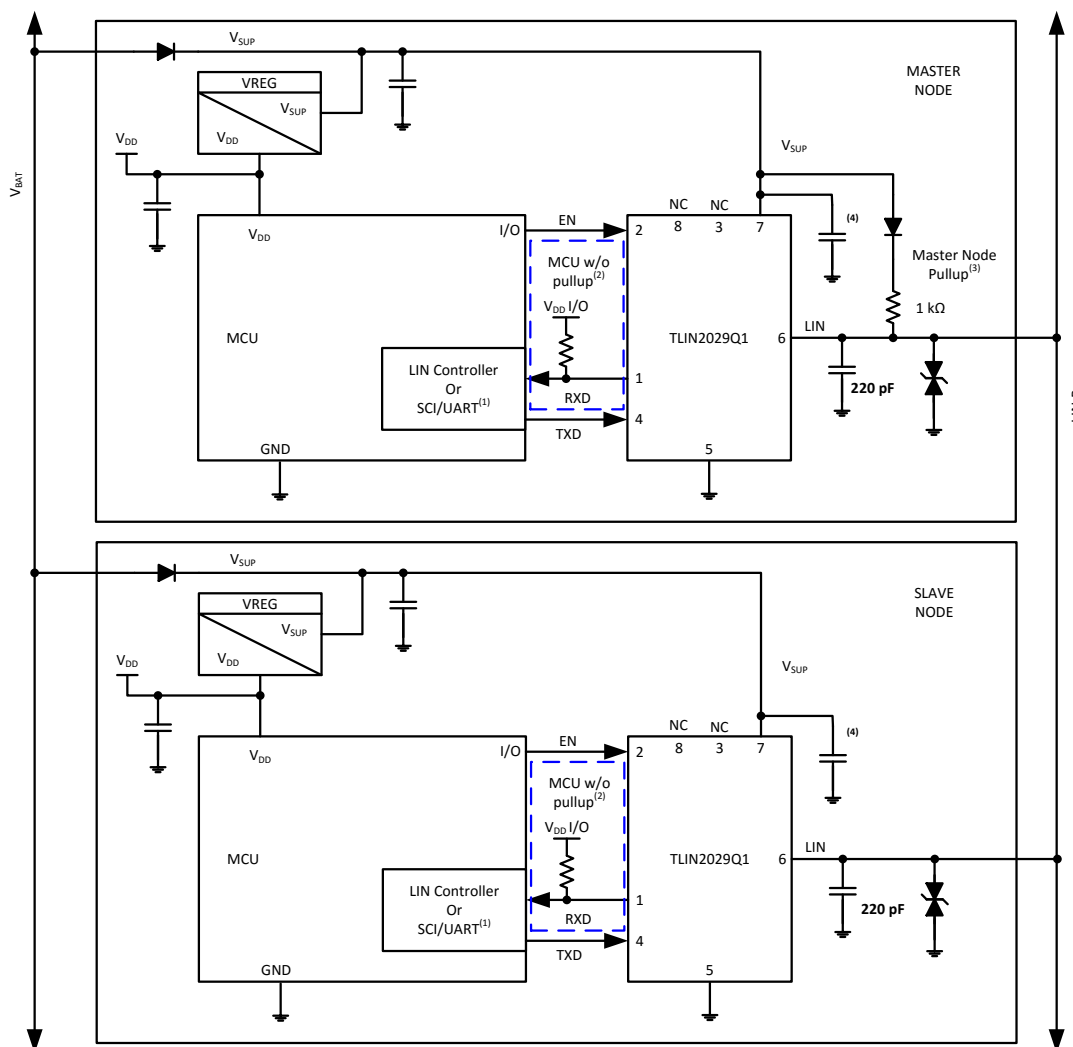

- (1) If RXD on MCU or LIN slave has internal pullup; no external pullup resistor is needed.
- (2) If RXD on MCU or LIN slave does not have an internal pullup requires external pullup resistor.
- (3) Master node applications require an external 1 kΩ pullup resistor and serial diode.
- (4) Decoupling capacitor values are system dependent but usually have 100 nF, 1 μF and ≥10 μF

Copyright © 2017, Texas Instruments Incorporated

Figure 30. Typical LIN Bus

Typical Application (continued)

9.2.1 Design Requirements

The RXD output structure is an open-drain output stage. This allows the TLIN2029-Q1 to be used with 3.3-V and 5-V I/O processor. If the RXD pin of the processor does not have an integrated pull-up, an external pull-up resistor to the processor's I/O supply voltage is required. The select external pull-up resistor value should be between 1 k Ω to 10 k Ω . The V_{SUP} pin of the device should be decoupled with a 100-nF capacitor as close to the supply pin of the device as possible. The system should include 1 μ F and \geq 10 μ F decoupling capacitors on V_{SUP} as per each application requirements.

9.2.2 Detailed Design Procedures

9.2.2.1 Normal Mode Application Note

When using the TLIN2029-Q1 in systems which are monitoring the RXD pin for a wake up request, special care should be taken during the mode transitions. The output of the RXD pin is indeterminate for the transition period between states as the receivers are switched. The application software should not look for an edge on the RXD pin indicating a wake up request until t_{MODE_CHANGE}. This is shown in Figure 22

9.2.2.2 Standby Mode Application Note

If the TLIN2029-Q1 detects an under voltage on V_{SUP} the RXD pin transitions low and would signal to the software that the TLIN2029-Q1 is in standby mode and should be returned to sleep mode for the lowest power state.

9.2.2.2.1 TXD Dominant State Timeout Application Note

The maximum dominant TXD time allowed by the TXD dominant state time out limits the minimum possible data rate of the device. The LIN protocol has different constraints for master and slave applications thus there are different maximum consecutive dominant bits for each application case and thus different minimum data rates.

9.2.3 Application Curves

and show the propagation delay from the TXD pin to the LIN pin for both dominant to recessive and recessive to dominant stated under lightly loaded conditions.

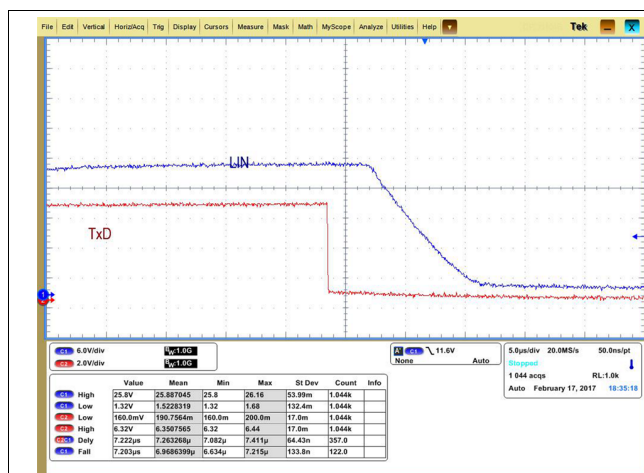

Figure 31. Dominant to Recessive Propagation

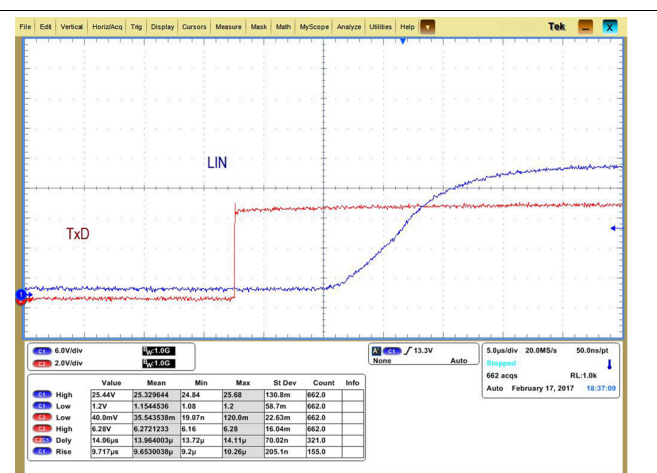

Figure 32. Recessive to Dominant Propagation

10 Power Supply Recommendations

The TLIN2029-Q1 was designed to operate directly off a car battery, or any other DC supply ranging from 4 V to 45 V. A 100 nF decoupling capacitor should be placed as close to the V_{SUP} pin of the device as possible.

11 Layout

In order for your PCB design to be successful, start with design of the protection and filtering circuitry. Because ESD and EFT transients have a wide frequency bandwidth from approximately 3 MHz to 3 GHz, high frequency layout techniques must be applied during PCB design. On chip IEC ESD protection is good for laboratory and portable equipment but is usually not sufficient for EFT and surge transients occurring in industrial environments. Therefore robust and reliable bus node design requires the use of external transient protection devices at the bus connectors. Placement at the connector also prevents these noisy events from propagating further into the PCB and system.

11.1 Layout Guidelines

- **Pin 1 (RXD):** The pin is an open drain output and requires an external pull-up resistor in the range of 1 k Ω and 10 k Ω to function properly. If the microprocessor paired with the transceiver does not have an integrated pull-up, an external resistor should be placed between RXD and the regulated voltage supply for the microprocessor.
- **Pin 2 (EN):** EN is an input pin that is used to place the device in a low power sleep mode. If this feature is not used the pin should be pulled high to the regulated voltage supply of the microprocessor through a series resistor, values between 1 k Ω and 10 k Ω . Additionally, a series resistor may be placed on the pin to limit current on the digital lines in the case of an over voltage fault.
- **Pin 3 (NC):** Not Connected.
- **Pin 4 (TXD):** The TXD pin is the transmit input signal to the device from the microcontroller. A series resistor can be placed to limit the input current to the device in the case of an over-voltage on this pin. A capacitor to ground can be placed close to the input pin of the device to filter noise.
- **Pin 5 (GND):** This is the ground connection for the device. This pin should be tied to the ground plane through a short trace with the use of two vias to limit total return inductance.
- **Pin 6 (LIN):** This pin connects to the LIN bus. For slave applications a 220 pF capacitor to ground is implemented. For master applications an additional series resistor and blocking diode should be placed between the LIN pin and the V_{SUP} pin. See .
- **Pin 7 (VSUP):** This is the supply pin for the device. A 100 nF decoupling capacitor should be placed as close to the device as possible.
- **Pin 8 (NC):** Not Connected.

NOTE

All ground and power connections should be made as short as possible and use at least two vias to minimize the total loop inductance.

11.2 Layout Example

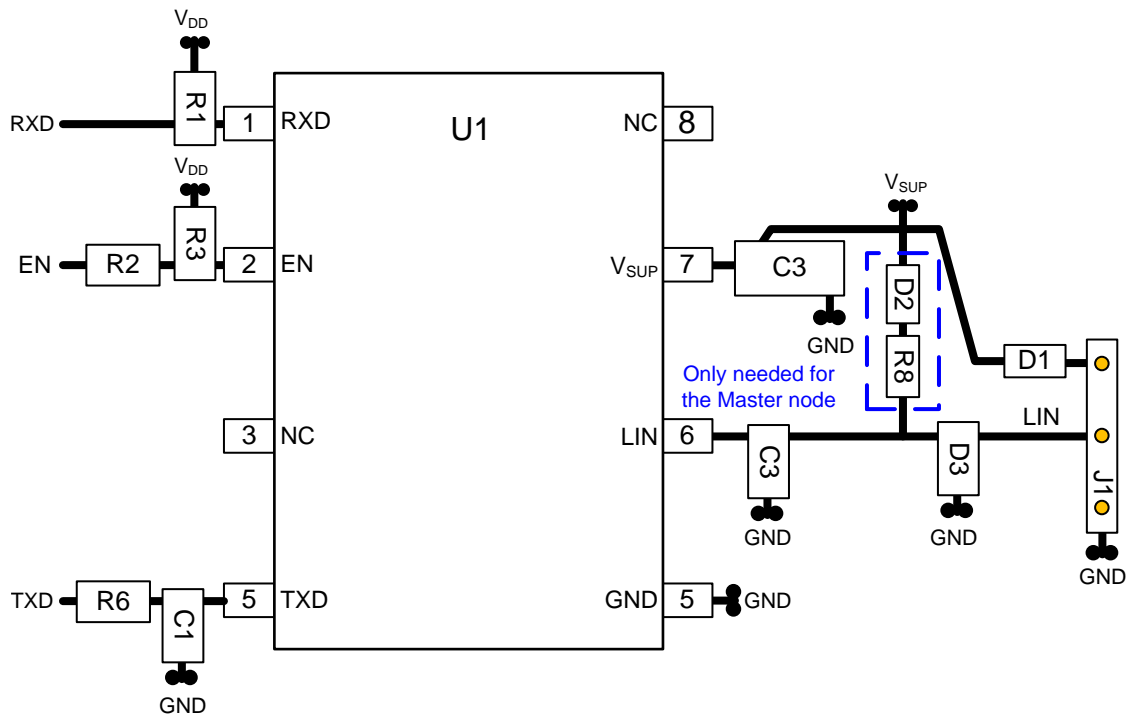

Figure 33. Layout Example

12 Device and Documentation Support

12.1 Documentation Support

12.1.1 Related Documentation

For related documentation see the following:

LIN Standards:

- ISO/DIS 17987-1.2: Road vehicles -- Local Interconnect Network (LIN) -- Part 1: General information and use case definition
- ISO/DIS 17987-4.2: Road vehicles -- Local Interconnect Network (LIN) -- Part 4: Electrical Physical Layer (EPL) specification 12V/24V
- SAEJ2602-1: LIN Network for Vehicle Applications
- LIN Specifications LIN 2.0, LIN 2.1, LIN 2.2 and LIN 2.2A

EMC requirements:

- SAEJ2962-1: Communication Transceivers Qualification Requirements - LIN
- HW Requirements for CAN, LIN, FR V1.3: German OEM requirements for LIN
- ISO 10605: Road vehicles - Test methods for electrical disturbances from electrostatic discharge
- ISO 11452-4:2011: Road vehicles - Component test methods for electrical disturbances from narrowband radiated electromagnetic energy - Part 4: Harness excitation methods
- ISO 7637-1:2015: Road vehicles - Electrical disturbances from conduction and coupling - Part 1: Definitions and general considerations
- ISO 7637-3: Road vehicles - Electrical disturbances from conduction and coupling - Part 3: Electrical transient transmission by capacitive and inductive coupling via lines other than supply lines
- IEC 62132-4:2006: Integrated circuits - Measurement of electromagnetic immunity 150 kHz to 1 GHz - Part 4: Direct RF power injection method
- IEC 61000-4-2
- IEC 61967-4
- CISPR25

Conformance Test requirements:

- ISO/DIS 17987-7.2: Road vehicles -- Local Interconnect Network (LIN) -- Part 7: Electrical Physical Layer (EPL) conformance test specification
- SAEJ2602-2: LIN Network for Vehicle Applications Conformance Test

12.2 Receiving Notification of Documentation Updates

To receive notification of documentation updates, navigate to the device product folder on ti.com. In the upper right corner, click on *Alert me* to register and receive a weekly digest of any product information that has changed. For change details, review the revision history included in any revised document.

12.3 Community Resources

The following links connect to TI community resources. Linked contents are provided "AS IS" by the respective contributors. They do not constitute TI specifications and do not necessarily reflect TI's views; see TI's [Terms of Use](#).

TI E2E™ Online Community *TI's Engineer-to-Engineer (E2E) Community*. Created to foster collaboration among engineers. At e2e.ti.com, you can ask questions, share knowledge, explore ideas and help solve problems with fellow engineers.

Design Support *TI's Design Support* Quickly find helpful E2E forums along with design support tools and contact information for technical support.

12.4 Trademarks

E2E is a trademark of Texas Instruments.

All other trademarks are the property of their respective owners.

12.5 Electrostatic Discharge Caution



This integrated circuit can be damaged by ESD. Texas Instruments recommends that all integrated circuits be handled with appropriate precautions. Failure to observe proper handling and installation procedures can cause damage.

ESD damage can range from subtle performance degradation to complete device failure. Precision integrated circuits may be more susceptible to damage because very small parametric changes could cause the device not to meet its published specifications.

12.6 Glossary

[SLYZ022](#) — *TI Glossary*.

This glossary lists and explains terms, acronyms, and definitions.

13 Mechanical, Packaging, and Orderable Information

The following pages include mechanical, packaging, and orderable information. This information is the most current data available for the designated devices. This data is subject to change without notice and revision of this document. For browser-based versions of this data sheet, refer to the left-hand navigation.



PACKAGE OUTLINE

D0008B

SOIC - 1.75 mm max height

SOIC

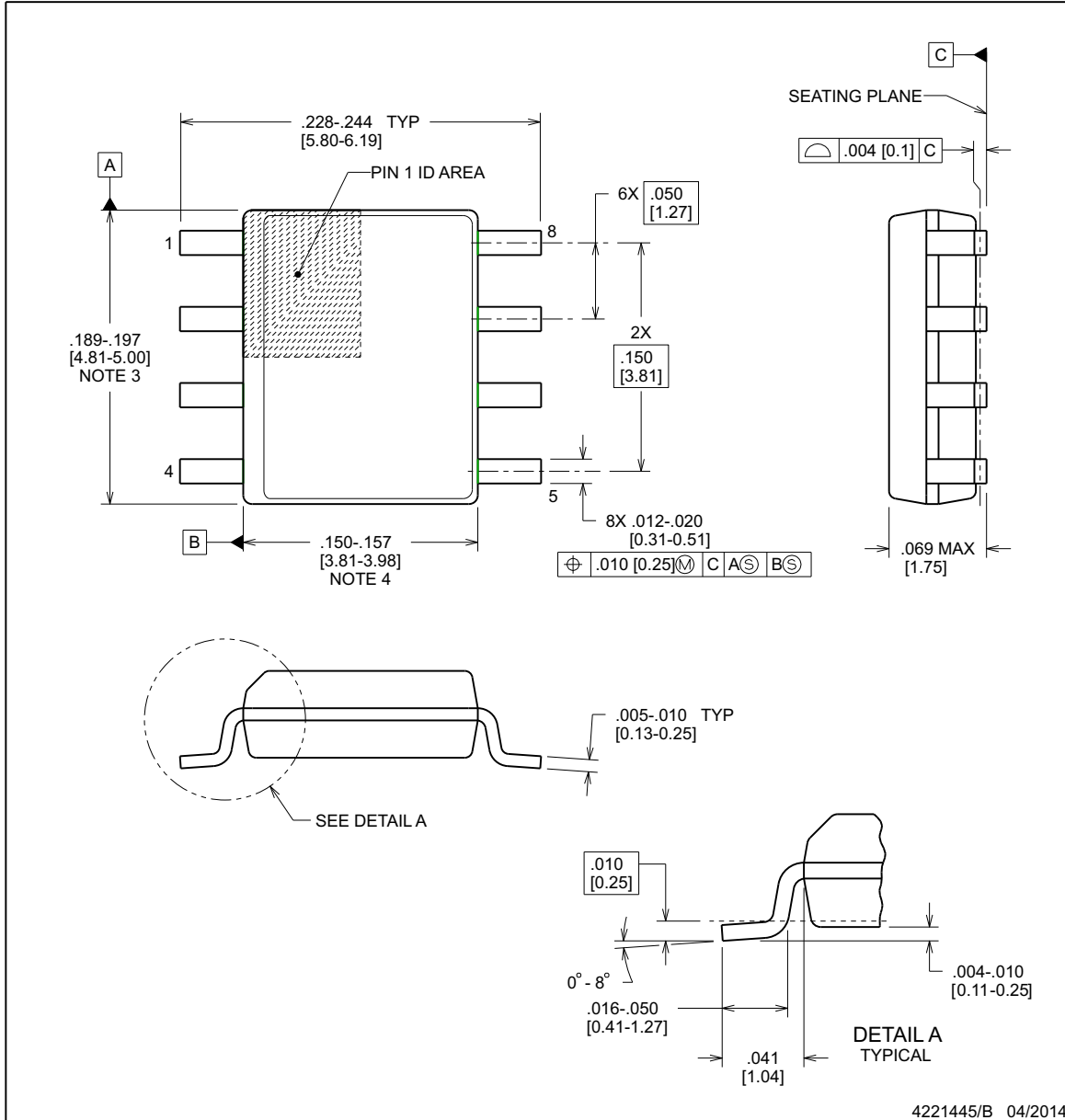

NOTES:

1. Linear dimensions are in inches [millimeters]. Dimensions in parenthesis are for reference only. Controlling dimensions are in inches. Dimensioning and tolerancing per ASME Y14.5M.
2. This drawing is subject to change without notice.
3. This dimension does not include mold flash, protrusions, or gate burrs. Mold flash, protrusions, or gate burrs shall not exceed $.006$ [0.15], per side.
4. This dimension does not include interlead flash.
5. Reference JEDEC registration MS-012, variation AA.

ADVANCE INFORMATION

EXAMPLE BOARD LAYOUT

D0008B

SOIC - 1.75 mm max height

SOIC

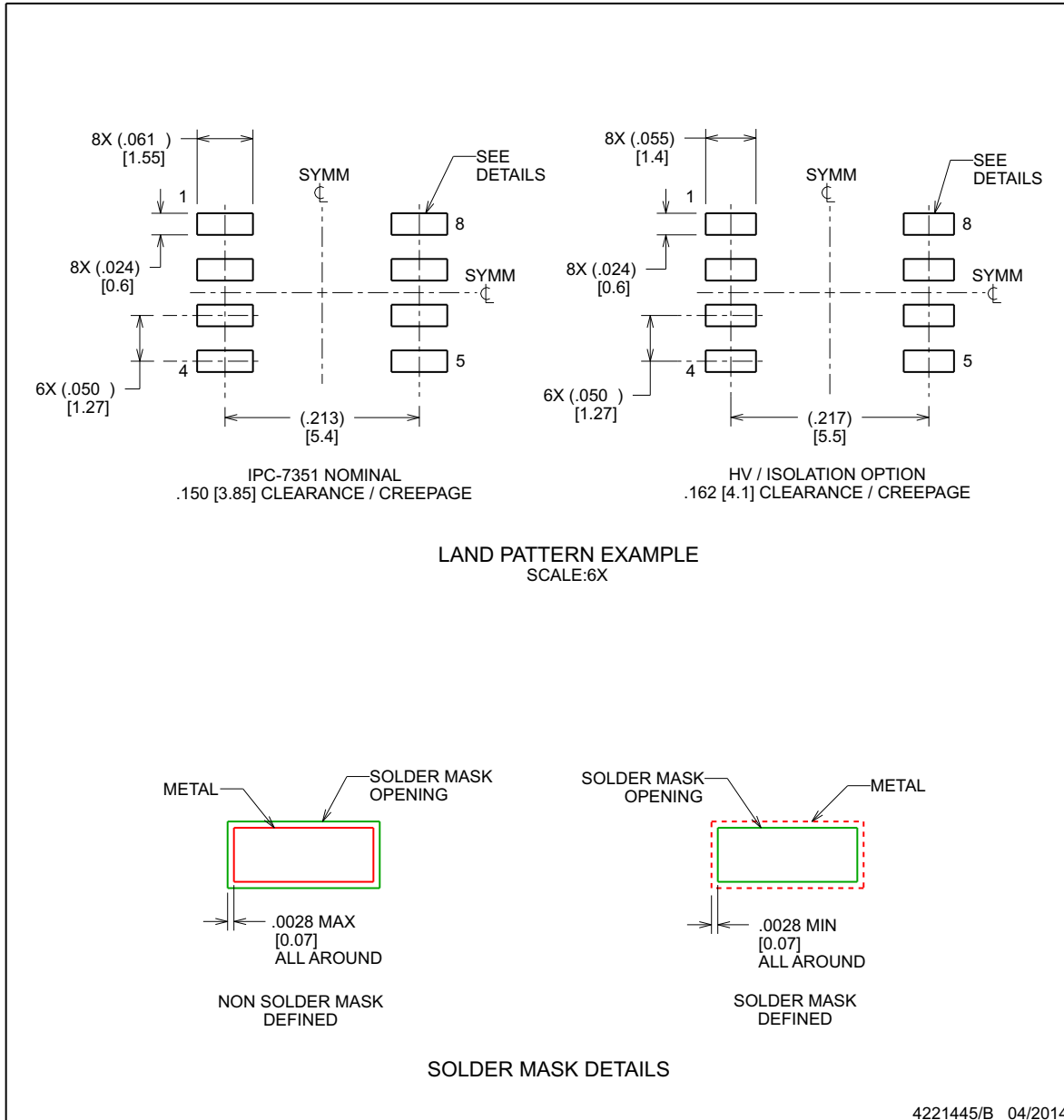

NOTES: (continued)

- 6. Publication IPC-7351 may have alternate designs.
- 7. Solder mask tolerances between and around signal pads can vary based on board fabrication site.

ADVANCE INFORMATION

EXAMPLE STENCIL DESIGN

D0008B

SOIC - 1.75 mm max height

SOIC

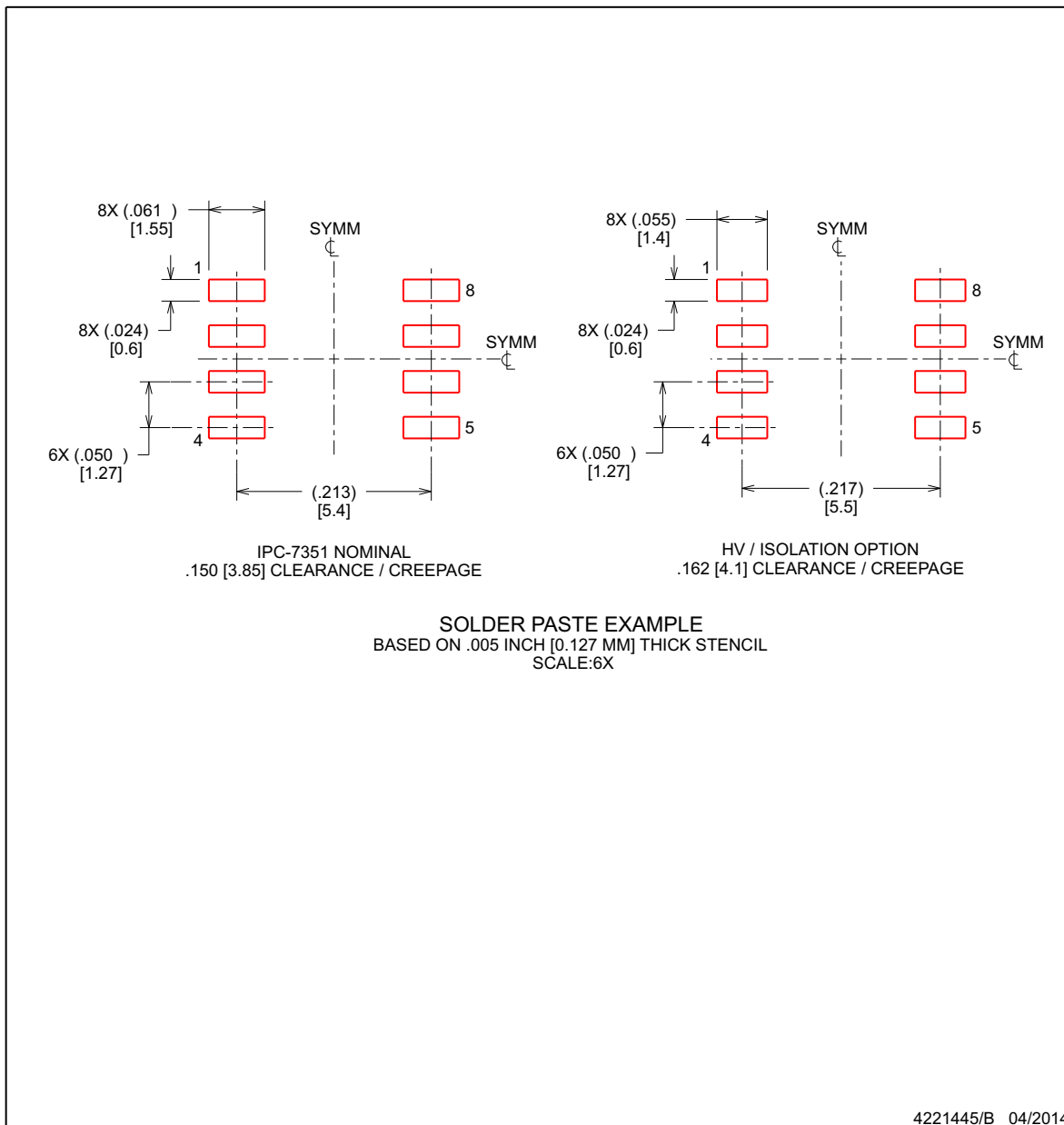

NOTES: (continued)

- 8. Laser cutting apertures with trapezoidal walls and rounded corners may offer better paste release. IPC-7525 may have alternate design recommendations.
- 9. Board assembly site may have different recommendations for stencil design.

ADVANCE INFORMATION



DRB0008F

PACKAGE OUTLINE

VSON - 1 mm max height

PLASTIC SMALL OUTLINE - NO LEAD

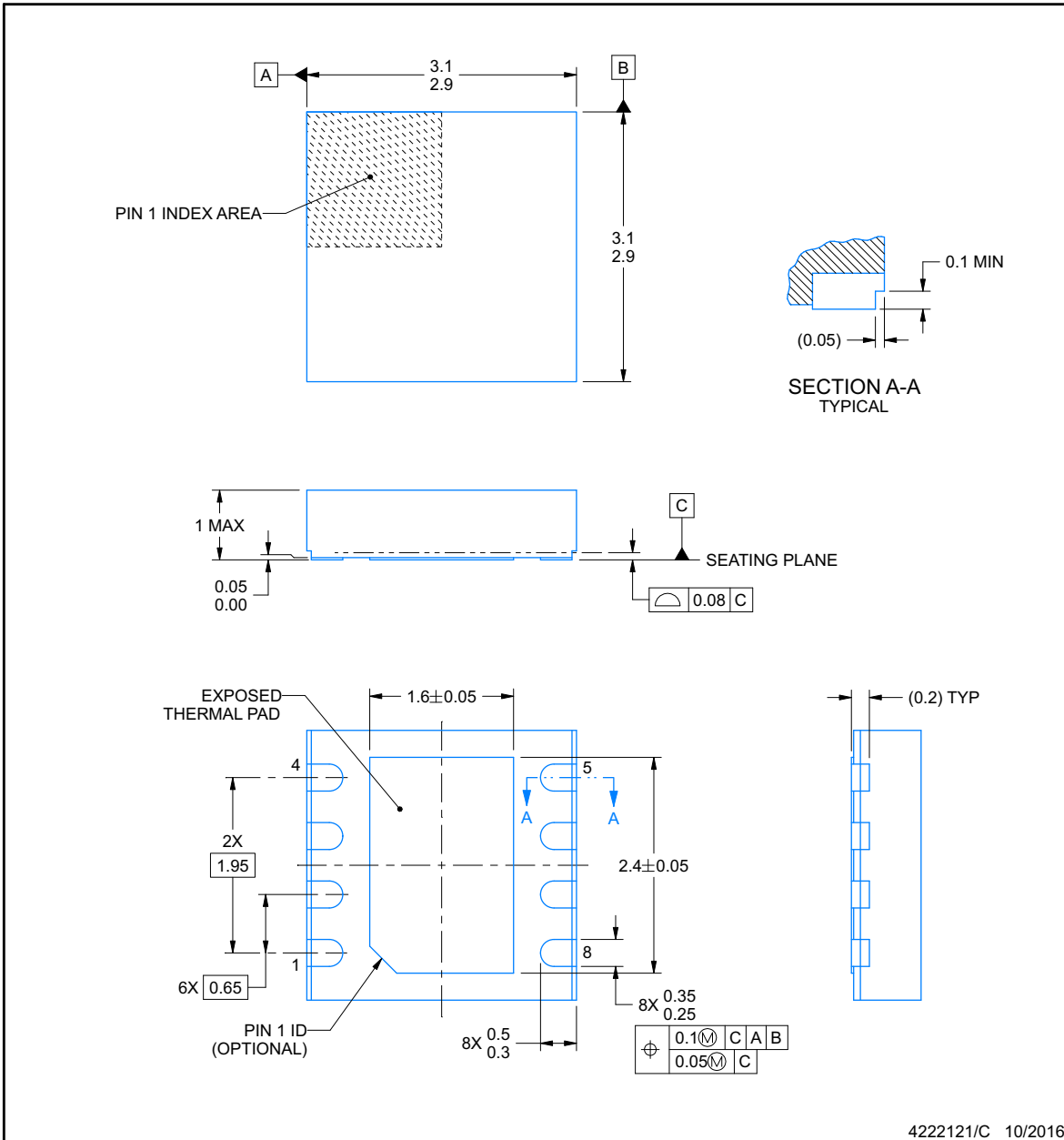

4222121/C 10/2016

NOTES:

1. All linear dimensions are in millimeters. Any dimensions in parenthesis are for reference only. Dimensioning and tolerancing per ASME Y14.5M.
2. This drawing is subject to change without notice.
3. The package thermal pad must be soldered to the printed circuit board for thermal and mechanical performance.

ADVANCE INFORMATION

EXAMPLE BOARD LAYOUT

DRB0008F

VSON - 1 mm max height

PLASTIC SMALL OUTLINE - NO LEAD

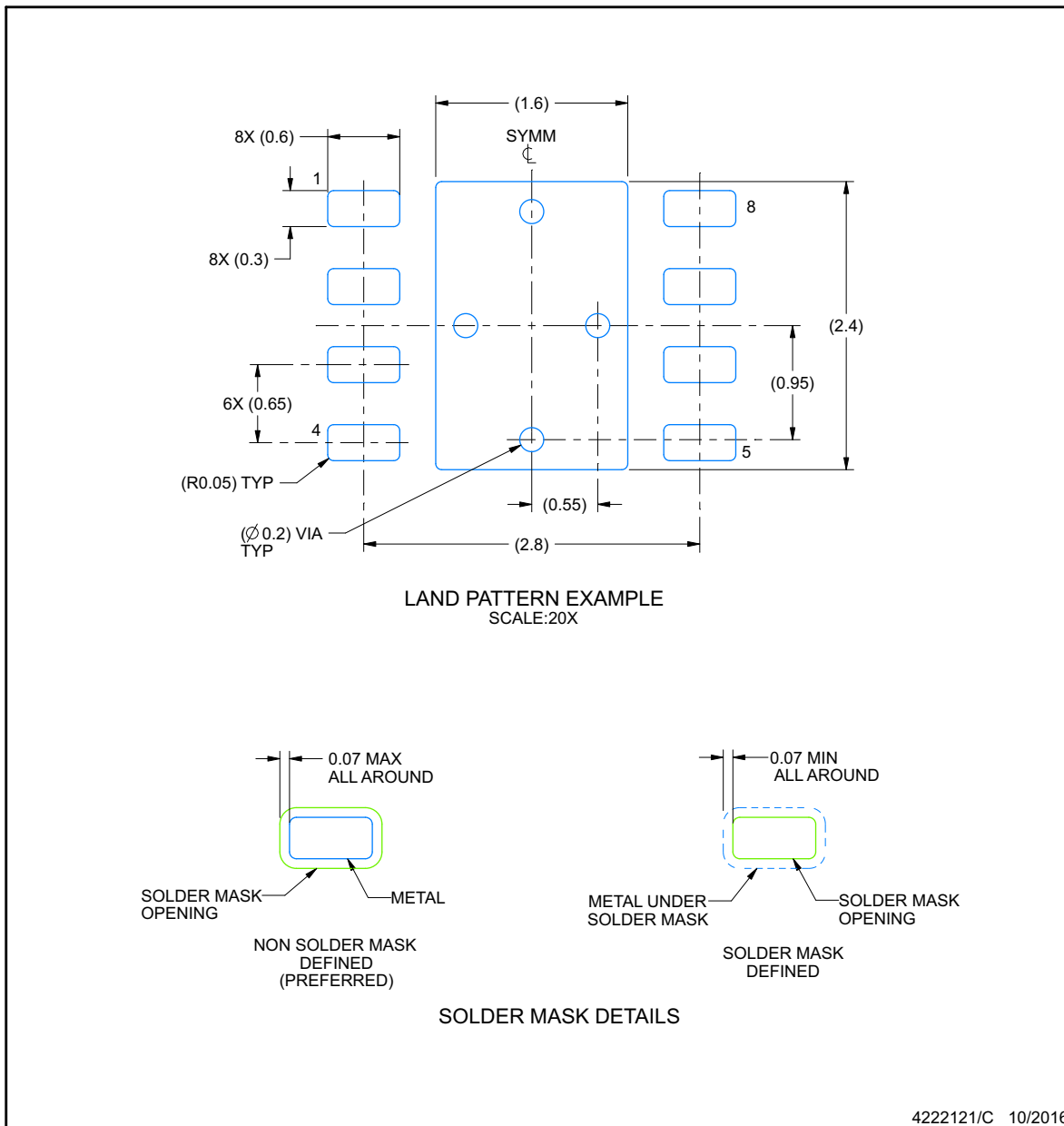

ADVANCE INFORMATION

NOTES: (continued)

- This package is designed to be soldered to a thermal pad on the board. For more information, see Texas Instruments literature number SLUA271 (www.ti.com/lit/sluea271).
- Vias are optional depending on application, refer to device data sheet. If any vias are implemented, refer to their locations shown on this view. It is recommended that vias under paste be filled, plugged or tented.

EXAMPLE STENCIL DESIGN

DRB0008F

VSON - 1 mm max height

PLASTIC SMALL OUTLINE - NO LEAD

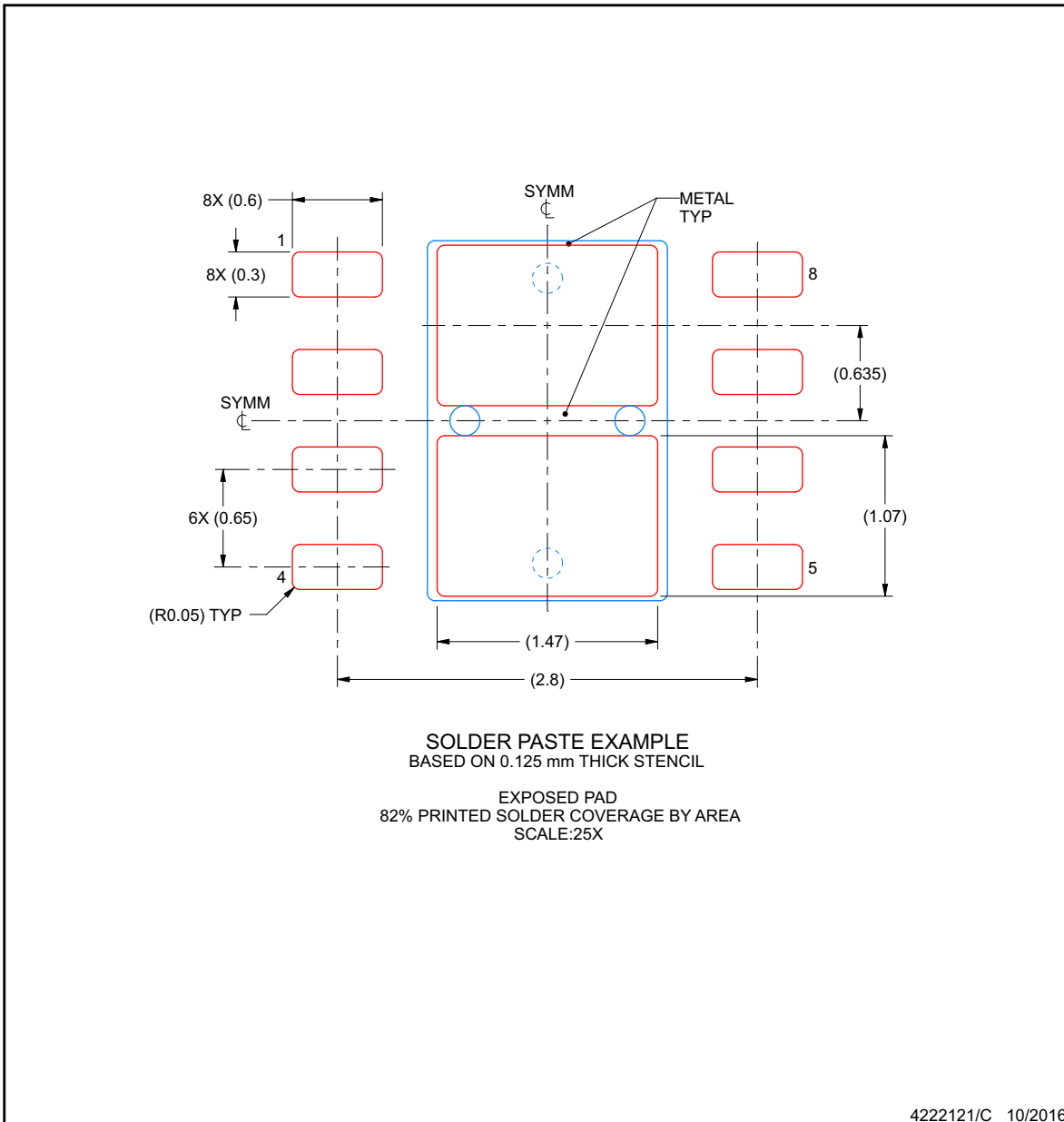

NOTES: (continued)

6. Laser cutting apertures with trapezoidal walls and rounded corners may offer better paste release. IPC-7525 may have alternate design recommendations.

ADVANCE INFORMATION

PACKAGING INFORMATION

Orderable Device	Status (1)	Package Type	Package Drawing	Pins	Package Qty	Eco Plan (2)	Lead/Ball Finish (6)	MSL Peak Temp (3)	Op Temp (°C)	Device Marking (4/5)	Samples
PTLIN2029DQ1	ACTIVE	SOIC	D	8	75	TBD	Call TI	Call TI	-40 to 125		Samples
TLIN2029DQ1	PREVIEW	SOIC	D	8	75	TBD	Call TI	Call TI	-40 to 125		
TLIN2029DRBRQ1	PREVIEW	SON	DRB	8	3000	TBD	Call TI	Call TI	-40 to 125	TL029	
TLIN2029DRBTQ1	PREVIEW	SON	DRB	8	250	TBD	Call TI	Call TI	-40 to 125	TL029	
TLIN2029DRQ1	PREVIEW	SOIC	D	8	2500	TBD	Call TI	Call TI	-40 to 125		

(1) The marketing status values are defined as follows:

ACTIVE: Product device recommended for new designs.

LIFEBUY: TI has announced that the device will be discontinued, and a lifetime-buy period is in effect.

NRND: Not recommended for new designs. Device is in production to support existing customers, but TI does not recommend using this part in a new design.

PREVIEW: Device has been announced but is not in production. Samples may or may not be available.

OBSELETE: TI has discontinued the production of the device.

(2) **RoHS:** TI defines "RoHS" to mean semiconductor products that are compliant with the current EU RoHS requirements for all 10 RoHS substances, including the requirement that RoHS substance do not exceed 0.1% by weight in homogeneous materials. Where designed to be soldered at high temperatures, "RoHS" products are suitable for use in specified lead-free processes. TI may reference these types of products as "Pb-Free".

RoHS Exempt: TI defines "RoHS Exempt" to mean products that contain lead but are compliant with EU RoHS pursuant to a specific EU RoHS exemption.

Green: TI defines "Green" to mean the content of Chlorine (Cl) and Bromine (Br) based flame retardants meet JS709B low halogen requirements of <=1000ppm threshold. Antimony trioxide based flame retardants must also meet the <=1000ppm threshold requirement.

(3) MSL, Peak Temp. - The Moisture Sensitivity Level rating according to the JEDEC industry standard classifications, and peak solder temperature.

(4) There may be additional marking, which relates to the logo, the lot trace code information, or the environmental category on the device.

(5) Multiple Device Markings will be inside parentheses. Only one Device Marking contained in parentheses and separated by a "~" will appear on a device. If a line is indented then it is a continuation of the previous line and the two combined represent the entire Device Marking for that device.

(6) Lead/Ball Finish - Orderable Devices may have multiple material finish options. Finish options are separated by a vertical ruled line. Lead/Ball Finish values may wrap to two lines if the finish value exceeds the maximum column width.

Important Information and Disclaimer:The information provided on this page represents TI's knowledge and belief as of the date that it is provided. TI bases its knowledge and belief on information provided by third parties, and makes no representation or warranty as to the accuracy of such information. Efforts are underway to better integrate information from third parties. TI has taken and continues to take reasonable steps to provide representative and accurate information but may not have conducted destructive testing or chemical analysis on incoming materials and chemicals. TI and TI suppliers consider certain information to be proprietary, and thus CAS numbers and other limited information may not be available for release.

In no event shall TI's liability arising out of such information exceed the total purchase price of the TI part(s) at issue in this document sold by TI to Customer on an annual basis.

IMPORTANT NOTICE

Texas Instruments Incorporated (TI) reserves the right to make corrections, enhancements, improvements and other changes to its semiconductor products and services per JESD46, latest issue, and to discontinue any product or service per JESD48, latest issue. Buyers should obtain the latest relevant information before placing orders and should verify that such information is current and complete.

TI's published terms of sale for semiconductor products (<http://www.ti.com/sc/docs/stdterms.htm>) apply to the sale of packaged integrated circuit products that TI has qualified and released to market. Additional terms may apply to the use or sale of other types of TI products and services.

Reproduction of significant portions of TI information in TI data sheets is permissible only if reproduction is without alteration and is accompanied by all associated warranties, conditions, limitations, and notices. TI is not responsible or liable for such reproduced documentation. Information of third parties may be subject to additional restrictions. Resale of TI products or services with statements different from or beyond the parameters stated by TI for that product or service voids all express and any implied warranties for the associated TI product or service and is an unfair and deceptive business practice. TI is not responsible or liable for any such statements.

Buyers and others who are developing systems that incorporate TI products (collectively, "Designers") understand and agree that Designers remain responsible for using their independent analysis, evaluation and judgment in designing their applications and that Designers have full and exclusive responsibility to assure the safety of Designers' applications and compliance of their applications (and of all TI products used in or for Designers' applications) with all applicable regulations, laws and other applicable requirements. Designer represents that, with respect to their applications, Designer has all the necessary expertise to create and implement safeguards that (1) anticipate dangerous consequences of failures, (2) monitor failures and their consequences, and (3) lessen the likelihood of failures that might cause harm and take appropriate actions. Designer agrees that prior to using or distributing any applications that include TI products, Designer will thoroughly test such applications and the functionality of such TI products as used in such applications.

TI's provision of technical, application or other design advice, quality characterization, reliability data or other services or information, including, but not limited to, reference designs and materials relating to evaluation modules, (collectively, "TI Resources") are intended to assist designers who are developing applications that incorporate TI products; by downloading, accessing or using TI Resources in any way, Designer (individually or, if Designer is acting on behalf of a company, Designer's company) agrees to use any particular TI Resource solely for this purpose and subject to the terms of this Notice.

TI's provision of TI Resources does not expand or otherwise alter TI's applicable published warranties or warranty disclaimers for TI products, and no additional obligations or liabilities arise from TI providing such TI Resources. TI reserves the right to make corrections, enhancements, improvements and other changes to its TI Resources. TI has not conducted any testing other than that specifically described in the published documentation for a particular TI Resource.

Designer is authorized to use, copy and modify any individual TI Resource only in connection with the development of applications that include the TI product(s) identified in such TI Resource. NO OTHER LICENSE, EXPRESS OR IMPLIED, BY ESTOPPEL OR OTHERWISE TO ANY OTHER TI INTELLECTUAL PROPERTY RIGHT, AND NO LICENSE TO ANY TECHNOLOGY OR INTELLECTUAL PROPERTY RIGHT OF TI OR ANY THIRD PARTY IS GRANTED HEREIN, including but not limited to any patent right, copyright, mask work right, or other intellectual property right relating to any combination, machine, or process in which TI products or services are used. Information regarding or referencing third-party products or services does not constitute a license to use such products or services, or a warranty or endorsement thereof. Use of TI Resources may require a license from a third party under the patents or other intellectual property of the third party, or a license from TI under the patents or other intellectual property of TI.

TI RESOURCES ARE PROVIDED "AS IS" AND WITH ALL FAULTS. TI DISCLAIMS ALL OTHER WARRANTIES OR REPRESENTATIONS, EXPRESS OR IMPLIED, REGARDING RESOURCES OR USE THEREOF, INCLUDING BUT NOT LIMITED TO ACCURACY OR COMPLETENESS, TITLE, ANY EPIDEMIC FAILURE WARRANTY AND ANY IMPLIED WARRANTIES OF MERCHANTABILITY, FITNESS FOR A PARTICULAR PURPOSE, AND NON-INFRINGEMENT OF ANY THIRD PARTY INTELLECTUAL PROPERTY RIGHTS. TI SHALL NOT BE LIABLE FOR AND SHALL NOT DEFEND OR INDEMNIFY DESIGNER AGAINST ANY CLAIM, INCLUDING BUT NOT LIMITED TO ANY INFRINGEMENT CLAIM THAT RELATES TO OR IS BASED ON ANY COMBINATION OF PRODUCTS EVEN IF DESCRIBED IN TI RESOURCES OR OTHERWISE. IN NO EVENT SHALL TI BE LIABLE FOR ANY ACTUAL, DIRECT, SPECIAL, COLLATERAL, INDIRECT, PUNITIVE, INCIDENTAL, CONSEQUENTIAL OR EXEMPLARY DAMAGES IN CONNECTION WITH OR ARISING OUT OF TI RESOURCES OR USE THEREOF, AND REGARDLESS OF WHETHER TI HAS BEEN ADVISED OF THE POSSIBILITY OF SUCH DAMAGES.

Unless TI has explicitly designated an individual product as meeting the requirements of a particular industry standard (e.g., ISO/TS 16949 and ISO 26262), TI is not responsible for any failure to meet such industry standard requirements.

Where TI specifically promotes products as facilitating functional safety or as compliant with industry functional safety standards, such products are intended to help enable customers to design and create their own applications that meet applicable functional safety standards and requirements. Using products in an application does not by itself establish any safety features in the application. Designers must ensure compliance with safety-related requirements and standards applicable to their applications. Designer may not use any TI products in life-critical medical equipment unless authorized officers of the parties have executed a special contract specifically governing such use. Life-critical medical equipment is medical equipment where failure of such equipment would cause serious bodily injury or death (e.g., life support, pacemakers, defibrillators, heart pumps, neurostimulators, and implantables). Such equipment includes, without limitation, all medical devices identified by the U.S. Food and Drug Administration as Class III devices and equivalent classifications outside the U.S.

TI may expressly designate certain products as completing a particular qualification (e.g., Q100, Military Grade, or Enhanced Product). Designers agree that it has the necessary expertise to select the product with the appropriate qualification designation for their applications and that proper product selection is at Designers' own risk. Designers are solely responsible for compliance with all legal and regulatory requirements in connection with such selection.

Designer will fully indemnify TI and its representatives against any damages, costs, losses, and/or liabilities arising out of Designer's non-compliance with the terms and provisions of this Notice.