



# Isolated Feedback Generator

## FEATURES

- An Amplitude-Modulation System for Transformer Coupling an Isolated Feedback Error Signal
- Low-Cost Alternative to Optical Couplers
- Internal 1% Reference and Error Amplifier
- Internal Carrier Oscillator Usable to 5mHz
- Modulator Synchronizable to an External Clock
- Loop Status Monitor

## DESCRIPTION

The UC1901 family is designed to solve many of the problems associated with closing a feedback control loop across a voltage isolation boundary. As a stable and reliable alternative to an optical coupler, these devices feature an amplitude modulation system which allows a loop error signal to be coupled with a small RF transformer or capacitor.

The programmable, high-frequency oscillator within the UC1901 series permits the use of smaller, less expensive transformers which can readily be built to meet the isolation requirements of today's line-operated power systems. As an alternative to RF operation, the external clock input to these devices allows synchronization to a system clock or to the switching frequency of a SMPS.

An additional feature is a status monitoring circuit which provides an active-low output when the sensed error voltage is within  $\pm 10\%$  of the reference. The Driver A output, Driver B output, and Status Output are disabled until the input supply has reached a sufficient level to allow proper operation of the device.

Since these devices can also be used as a DC driver for optical couplers, the benefits of 4.5 to 40V supply operation, a 1% accurate reference, and a high gain general purpose amplifier offer advantages even though an AC system may not be desired.

## UC1901 SIMPLIFIED SCHEMATIC

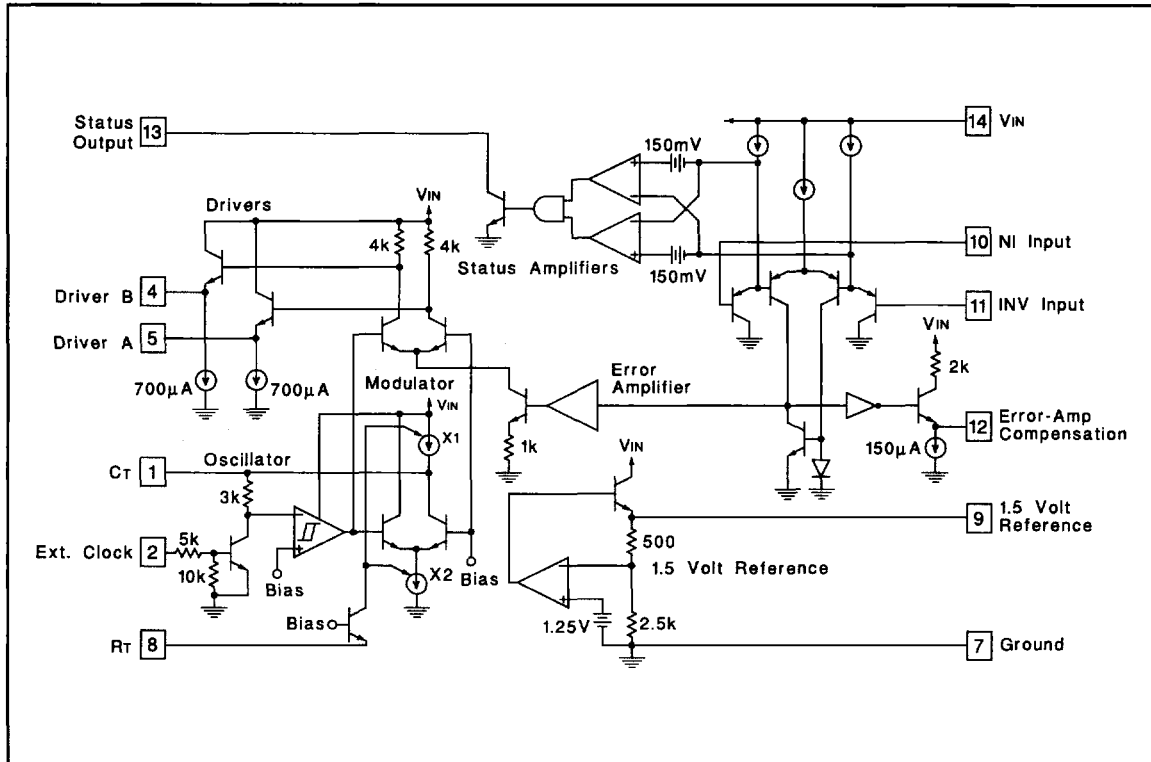

**ABSOLUTE MAXIMUM RATINGS (Note 1)**

Input Supply Voltage, $V_{IN}$ .....	40V
Reference Output Current .....	-10mA
Driver Output Currents .....	-35mA
Status Indicator Voltage .....	40V
Status Indicator Current .....	20mA
Ext. Clock Input .....	40V
Error Amplifier Inputs .....	-0.5V to +35V
Power Dissipation at $T_A = 25^\circ\text{C}$ .....	1000mW
Power Dissipation at $T_c = 25^\circ\text{C}$ .....	2000mW
Operating Junction Temperature .....	-55°C to +150°C
Storage Temperature .....	-65°C to +150°C
Lead Temperature (Soldering, 10 seconds) .....	300°C

Note 1: Voltages are referenced to ground, Pin 7.  
Currents are positive into, negative out of the specified terminal.

Note 2: Consult Packaging section of Databook for thermal limitations and considerations of package.

**CONNECTION DIAGRAMS**

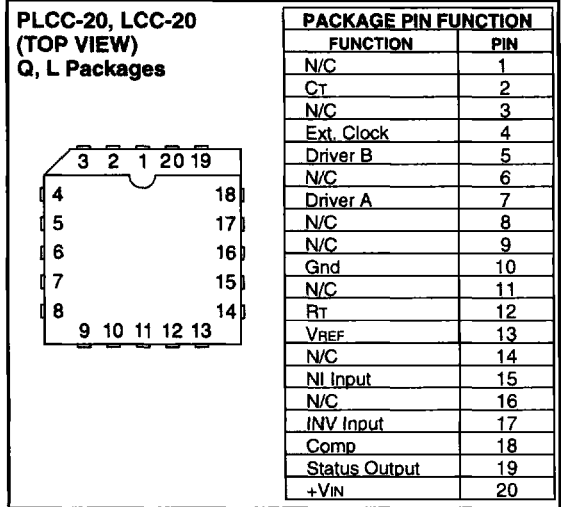
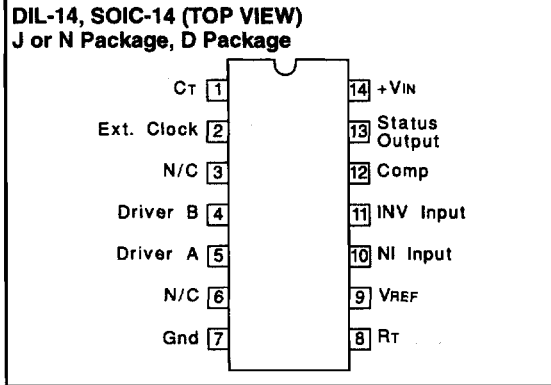

**ELECTRICAL CHARACTERISTICS:** Unless otherwise stated, these specifications apply for  $T_A = 55^\circ\text{C}$  to  $+125^\circ\text{C}$  for the UC1901;  $-40^\circ\text{C}$  to  $+85^\circ\text{C}$  for the UC2901; and  $0^\circ\text{C}$  to  $+70^\circ\text{C}$  for the UC3901;  $V_{IN} = 10\text{V}$ ,  $R_T = 10\text{k}\Omega$ ,  $C_T = 820\text{pF}$ ,  $T_A = T_J$ .

PARAMETER	TEST CONDITIONS	UC1901/UC2901			UC3901			UNITS
		MIN	TYP	MAX	MIN	TYP	MAX	
<b>Reference Section</b>								
Output Voltage	$T_J = 25^\circ\text{C}$	1.485	1.5	1.515	1.47	1.5	1.53	V
	$T_{MIN} \leq T_J \leq T_{MAX}$	1.470	1.5	1.530	1.455	1.5	1.545	
Line Regulation	$V_{IN} = 4.5$ to $35\text{V}$		2	10		2	15	mV
Load Regulation	$I_{OUT} = 0$ to $5\text{mA}$		4	10		4	15	mV
Short Circuit Current	$T_J = 25^\circ\text{C}$		-35	-55		-35	-55	mV
<b>Error Amplifier Section (To Compensation Terminal)</b>								
Input Offset Voltage	$V_{CM} = 1.5\text{V}$		1	4		1	8	mV
Input Bias Current	$V_{CM} = 1.5\text{V}$		-1	-3		-1	-6	$\mu\text{A}$
Input Offset Current	$V_{CM} = 1.5\text{V}$		0.1	1		0.1	2	$\mu\text{A}$
Small Signal Open Loop Gain		40	60		40	60		dB
CMRR	$V_{CM} = 0.5$ to $7.5\text{V}$	60	80		60	80		dB
PSRR	$V_{IN} = 2$ to $25\text{V}$	80	100		80	100		dB
Output Swing, $\Delta V_o$		0.4	0.7		0.4	0.7		V
Maximum Sink Current		90	150		90	150		$\mu\text{A}$
Maximum Source Current		-2	-3		-2	-3		mA
Gain Band Width Product			1			1		MHz
Slew Rate			0.3			0.3		V/ $\mu\text{S}$
<b>Modulators/Drivers Section (From Compensation Terminal)</b>								
Voltage Gain		11	12	13	10	12	14	dB
Output Swing		$\pm 1.6$	$\pm 2.8$		$\pm 1.6$	$\pm 2.8$		V

**ELECTRICAL CHARACTERISTICS (cont.):**

Unless otherwise stated, these specifications apply for  $T_A = 55^\circ\text{C}$  to  $+125^\circ\text{C}$  for the UC1901;  $-40^\circ\text{C}$  to  $+85^\circ\text{C}$  for the UC2901; and  $0^\circ\text{C}$  to  $+70^\circ\text{C}$  for the UC3901;  $V_{IN} = 10\text{V}$ ,  $R_T = 10\text{k}\Omega$ ,  $C_T = 820\text{pF}$ ,  $T_A = T_J$ .

PARAMETER	TEST CONDITIONS	UC1901/UC2901			UC3901			UNITS
		MIN	TYP	MAX	MIN	TYP	MAX	
<b>Modulators/Drivers Section (cont.)</b>								
Driver Sink Current		500	700		500	700		$\mu\text{A}$
Driver Source Current		-15	-35		-15	-35		$\text{mA}$
Gain Band Width Product			25			25		$\text{MHz}$
<b>Oscillator Section</b>								
Initial Accuracy	$T_J = 25^\circ\text{C}$	140	150	160	130	150	170	$\text{kHz}$
	$T_{MIN} \leq T_J \leq T_{MAX}$	130		170	120		180	$\text{kHz}$
Line Sensitivity	$V_{IN} = 5$ to $35\text{V}$		.15	.35		.15	.60	$\%/V$
Maximum Frequency	$R_T = 10\text{k}$ , $C_T = 10\text{pF}$		5			5		$\text{MHz}$
Ext. Clock Low Threshold	Pin 1 (CT) = $V_{IN}$	0.5			0.5			$\text{V}$
Ext. Clock High Threshold	Pin 1 (CT) = $V_{IN}$			1.6			1.6	$\text{V}$
<b>Status Indicator Section</b>								
Input Voltage Window	@ E/A Inputs, $V_{CM} = 1.5\text{V}$	$\pm 135$	$\pm 150$	$\pm 165$	$\pm 130$	$\pm 150$	$\pm 170$	$\text{mV}$
Saturation Voltage	E/A $\Delta$ Input = $0\text{V}$ , $I_{SINK} = 1.6\text{mA}$			0.45			0.45	$\text{V}$
Max. Output Current	Pin 13 = $3\text{V}$ , E/A $\Delta$ Input = $0.0\text{V}$	8	15		8	15		$\text{mA}$
Leakage Current	Pin 13 = $40\text{V}$ , E/A $\Delta$ Input = $0.2\text{V}$		.05	1		.05	5	$\mu\text{A}$
Supply Current	$V_{IN} = 35\text{V}$		5	8		5	10	$\text{mA}$
<b>UVLO Section</b>								
Drivers Enabled Threshold	At Input Supply $V_{IN}$		3.9	4.5		3.9	4.5	$\text{V}$
Status Output Enabled Threshold	At Input Supply $V_{IN}$		3.9	4.5		3.9	4.5	$\text{V}$
Change in Reference Output	When $V_{IN}$ Reaches UVLO Threshold		-2	-30		-2	-30	$\text{mV}$



GENERAL POWER SUPPLY

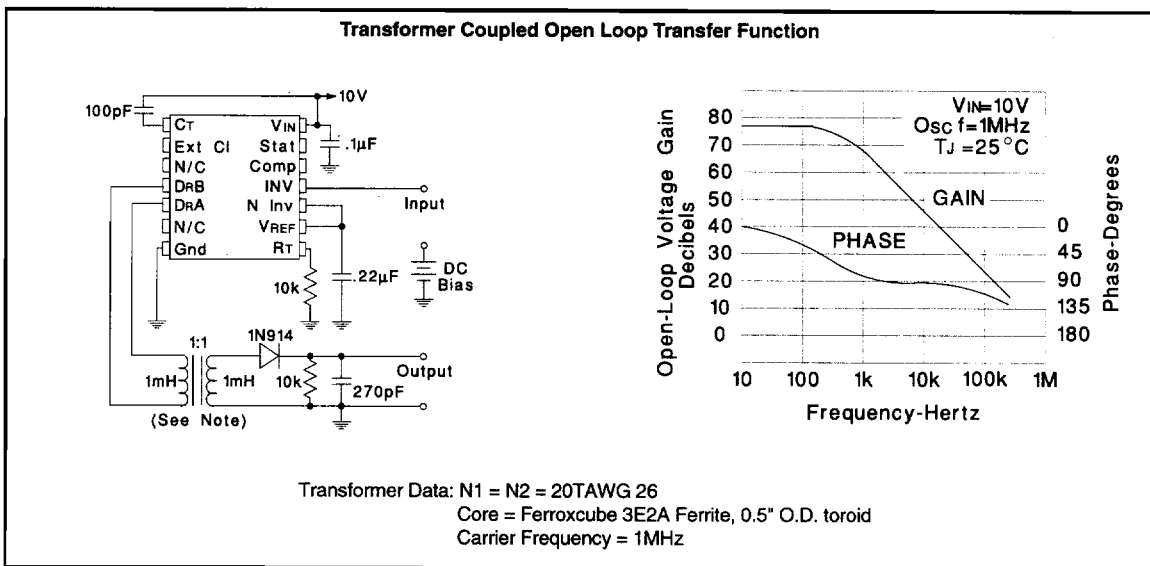

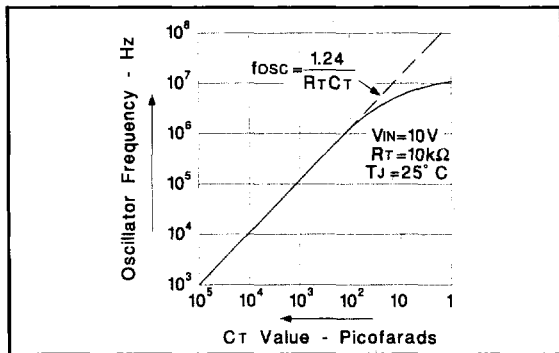

Oscillator Frequency

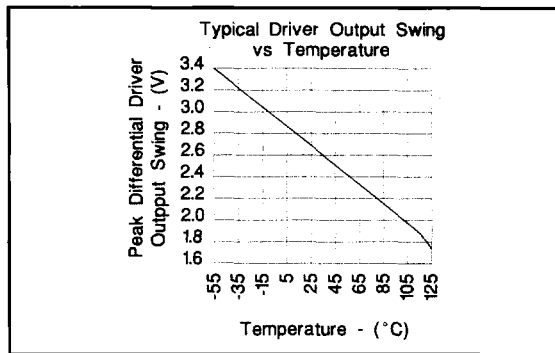

Typical Driver Output Swing vs Temperature

### APPLICATION INFORMATION

The error amplifier compensation terminal, Pin 12, is intended as a source of feedback to the amplifier's inverting input at Pin 11. For most applications, a series DC blocking capacitor should be part of the feedback network. The amplifier is internally compensated for unity feedback.

The waveform at the driver outputs is a squarewave with an amplitude that is proportional to the error amplifier input signal. There is a fixed 12dB of gain from the error amplifier compensation pin to the modulator driver outputs. The frequency of the output waveform is controlled by either the internal oscillator or an external clock signal. With the internal oscillator the squarewave will have a

fixed 50% duty cycle. If the internal oscillator is disabled by connecting Pin 1, CR, to VIN then the frequency and duty cycle of the output will be determined by the input clock waveform at Pin 2. If the oscillator remains disabled and there is not clock input at Pin 2, there will be a linear 12dB of signal gain to one or the other of the driver outputs depending on the DC state of Pin 2.

The driver outputs are emitter followers which will source a minimum of 15mA of current. The sink current, internally limited at 700μA, can be increased by adding resistors to ground at the driver outputs.

### R.F. Transformer Coupled Feedback

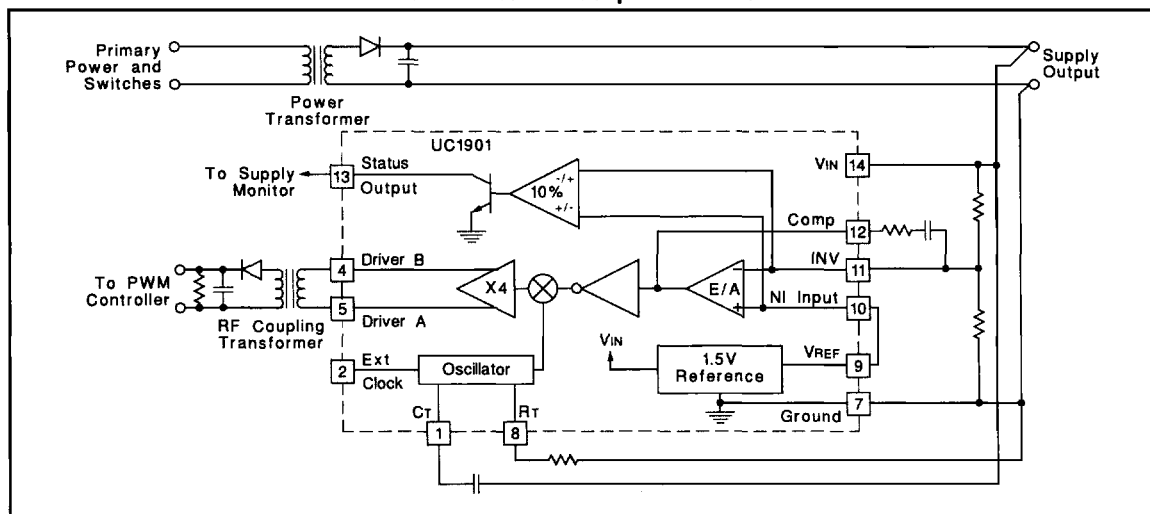

Feedback Coupled at Switching Frequency

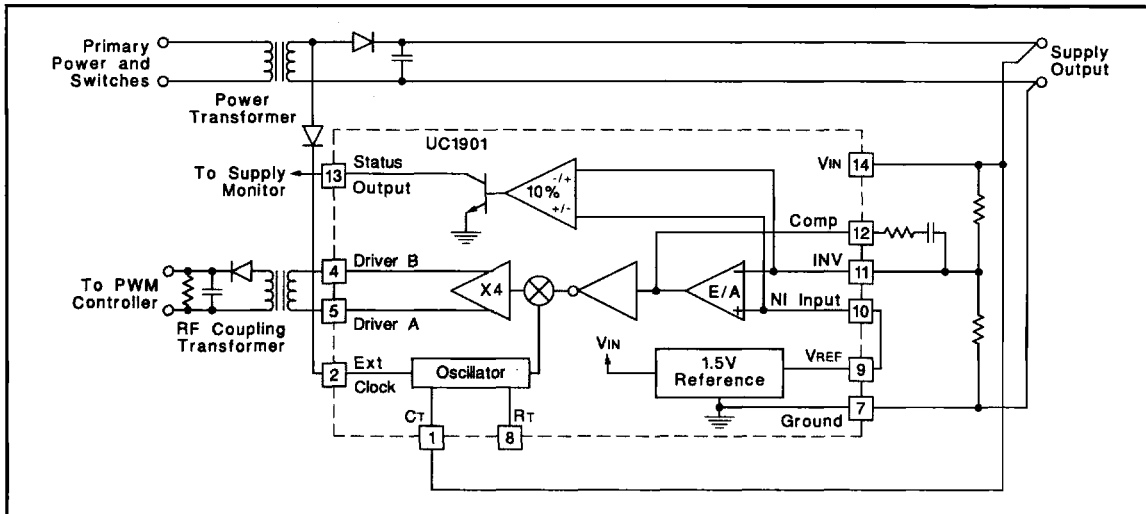

TYPICAL APPLICATION

Optically Coupled DC Feedback

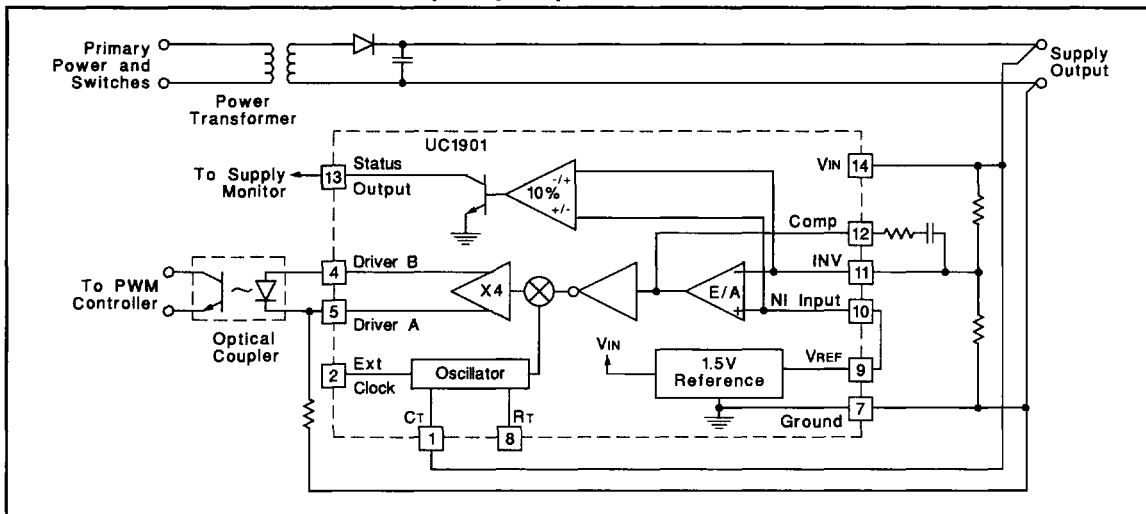

GENERAL POWER SUPPLY