

---

## Features

- 2-Phase 1 A Stepping Motor Driver
- Compensated Half Step Operation
- Chopper Current Control
- Unidirectional Single Wire Bus Interface with Error Feedback
- Intelligent Travel Operation Control
- Referencing by Extending or Retracting

## Application

- Dynamic Headlamp Adjustment

## Benefits

- Error Recognition with Feedback
- Short Circuit Protected Outputs
- Overtemperature Warning and Shut Off
- Supply Voltage Supervision

Electrostatic sensitive device.  
Observe precautions for handling.



## Description

The circuit serves to control a stepping motor for dynamic headlamp beam adjustment in automobiles. Two chopper-controlled H-bridges serve as the stepping motor driver. The circuit receives the commands to control the stepping motor by means of a unidirectional serial single-wire bus.

An integrated process control independently moves the stepping motor into the new desired position. This allows it to be automatically accelerated and slowed down. The stepping motor is operated in compensated half-step operation. The maximum clock frequency at which the stepping motor is operated depends on the supply voltage, the chip temperature, the operating mode, and position difference.



---

## Intelligent Stepper Motor Driver

---

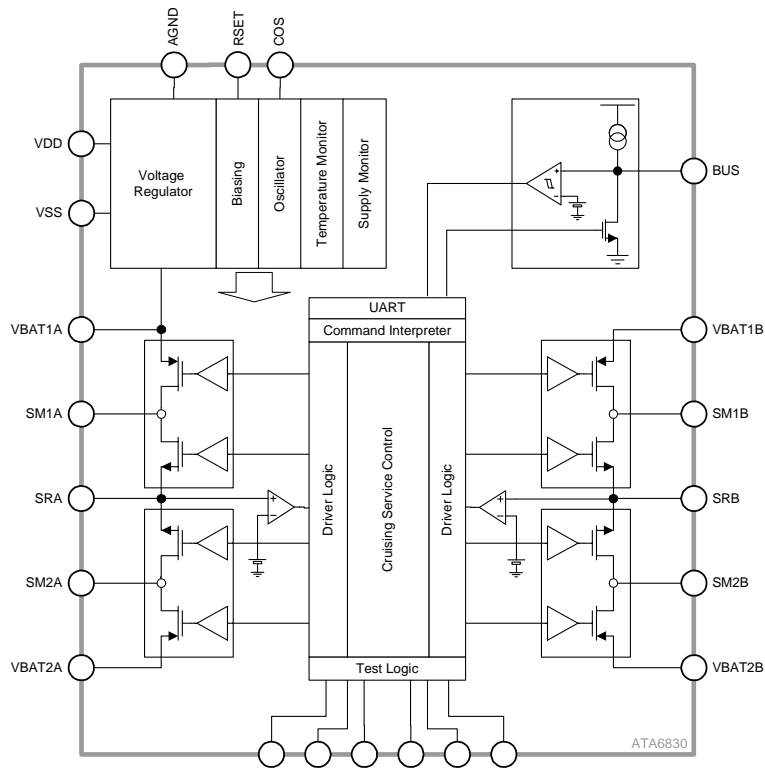
**ATA6830**

**Preliminary**

Rev. 4575A-BCD-12/02

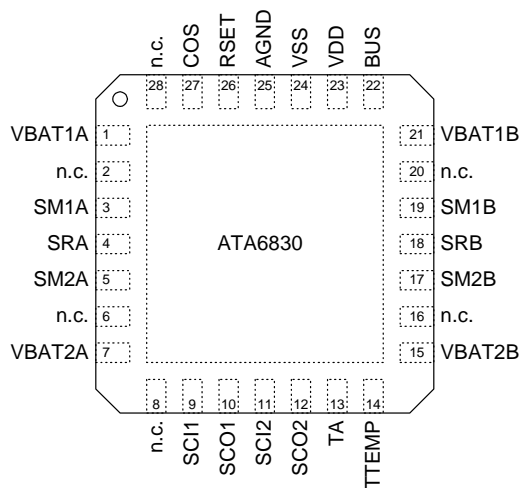


**Figure 1.** Block Diagram



## Pin Configuration

**Figure 2.** Pinning HP-VFQFP-N28



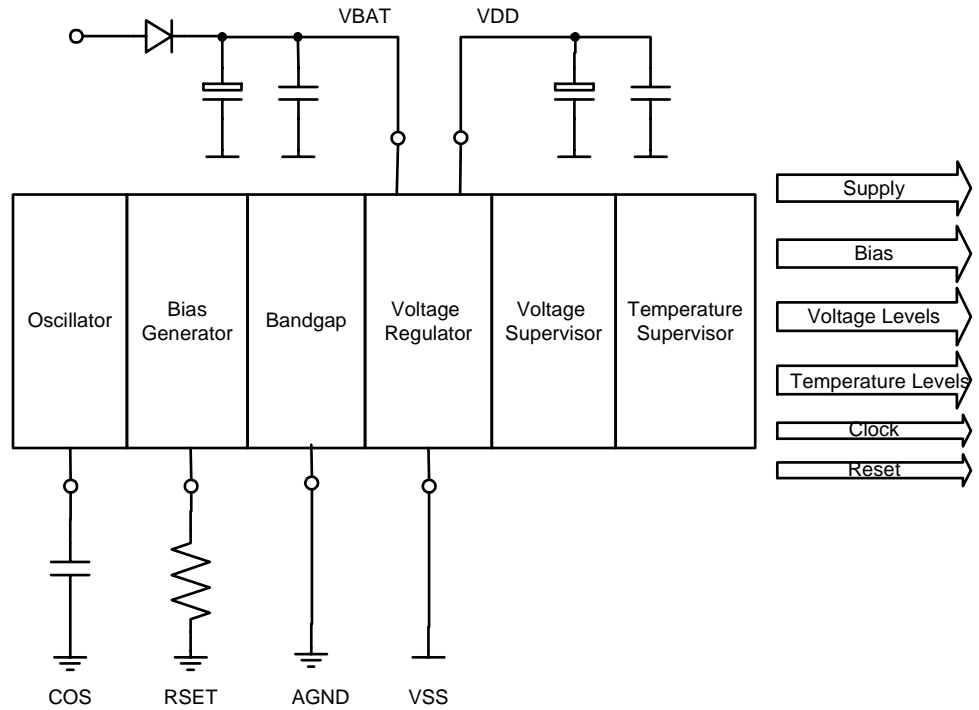
## Pin Description

Pin	Symbol	Function
1	VBAT1A	Battery voltage
2	n.c.	Not connected
3	SM1A	Connection for stepping motor winding A
4	SRA	Sense resistor A connection
5	SM2A	Connection for stepping motor winding A
6	n.c.	Not connected
7	VBAT2A	Battery voltage
8	n.c.	Not connected
9	SCI1	Test pin, please connect to ground for EMC reasons
10	SCO1	Test pin, please connect to ground for EMC reasons
11	SCI2	Test pin, please connect to ground for EMC reasons
12	SCO2	Test pin, please connect to ground for EMC reasons
13	TA	Test pin, please connect to ground for EMC reasons
14	TTEMP	Test pin, please connect to ground for EMC reasons
15	VBAT2B	Battery voltage
16	n.c.	Not connected
17	SM2B	Connection for stepping motor winding B
18	SRB	Sense resistor B connection
19	SM1B	Connection for stepping motor winding B
20	n.c.	Not connected
21	VBAT1B	Battery voltage
22	BUS	Receives the control instructions via the single wire bus from the controller
23	VDD	5 V supply voltage output
24	VSS	Digital signal ground
25	AGND	Analog signal ground
26	RSET	Reference current setting. Connected externally with a resistor to AGND. The value of the resistor determines all internal current sources and sinks.
27	COS	Oscillator pin, connected externally with a capacitor to AGND. The value of the capacitance determines the chopper frequency and the baud rate for data reception.
28	n.c.	Not connected

# Functional Description

## Analog Blocks

Figure 3. Analog Blocks



The circuit contains an integrated 5 V regulator to supply the internal logic and analog circuit blocks. The regulator uses an adjusted bandgap as voltage reference. Also all other parts that require an excellent voltage reference, such as the voltage monitoring block refer to the bandgap.

The bias generator derives its accurate currents from an external reference resistor. The oscillator is used for clocking the digital system. All timings like the baud rate, the step duration and the chopper frequency are determined from it. An external capacitor is used for generating the frequency.

The voltage monitoring enables the circuit to drive the stepping motor at different battery voltage levels. According to the battery voltage the stepping motor will be accelerated to a maximum step velocity. In case of under or over voltage the motor will shut off. A temperature monitoring is used for shut off at overtemperature conditions and current boost in case of low temperature.

## Digital Blocks

Figure 4. Digital Blocks

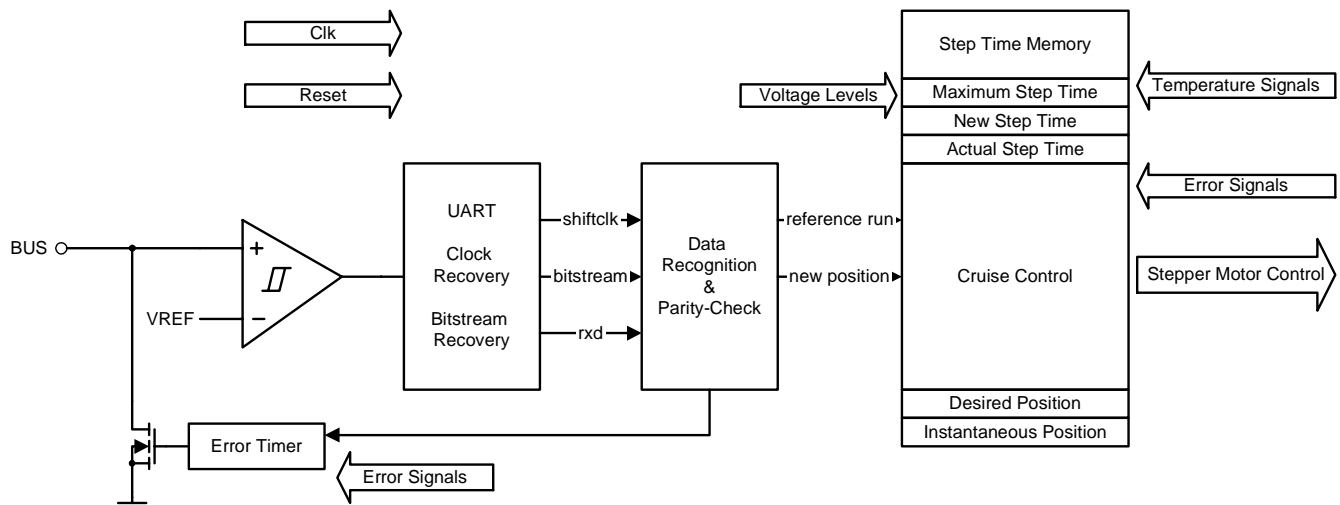


Figure 4 shows all digital blocks of the circuit. The stepping motor will be controlled by commands via the bus input pin. An analog comparator is used as a level shifter at the input. There is also a possibility of clamping the bus pin to ground. This will be used after detecting an error to feedback this to the microcontroller.

The next block is a UART. Its task is clock recovery and data recognition of the incoming bit stream. For clock recovery a special bitstream is used after each power on. The generated bitstream will be analyzed and after a correct parity check interpreted for execution.

A sophisticated cruise control generates all control signals for the two H-bridge drivers. It uses an internal step-time table for accelerating and decelerating the stepping motor depending on the actual and desired position and the temperature and voltage levels. Exception handling is integrated to interpret and react on the temperature, supply voltage, and coil-current signals from the analog part.

## Stepping Motor Driver

Figure 5. Stepping Motor Driver

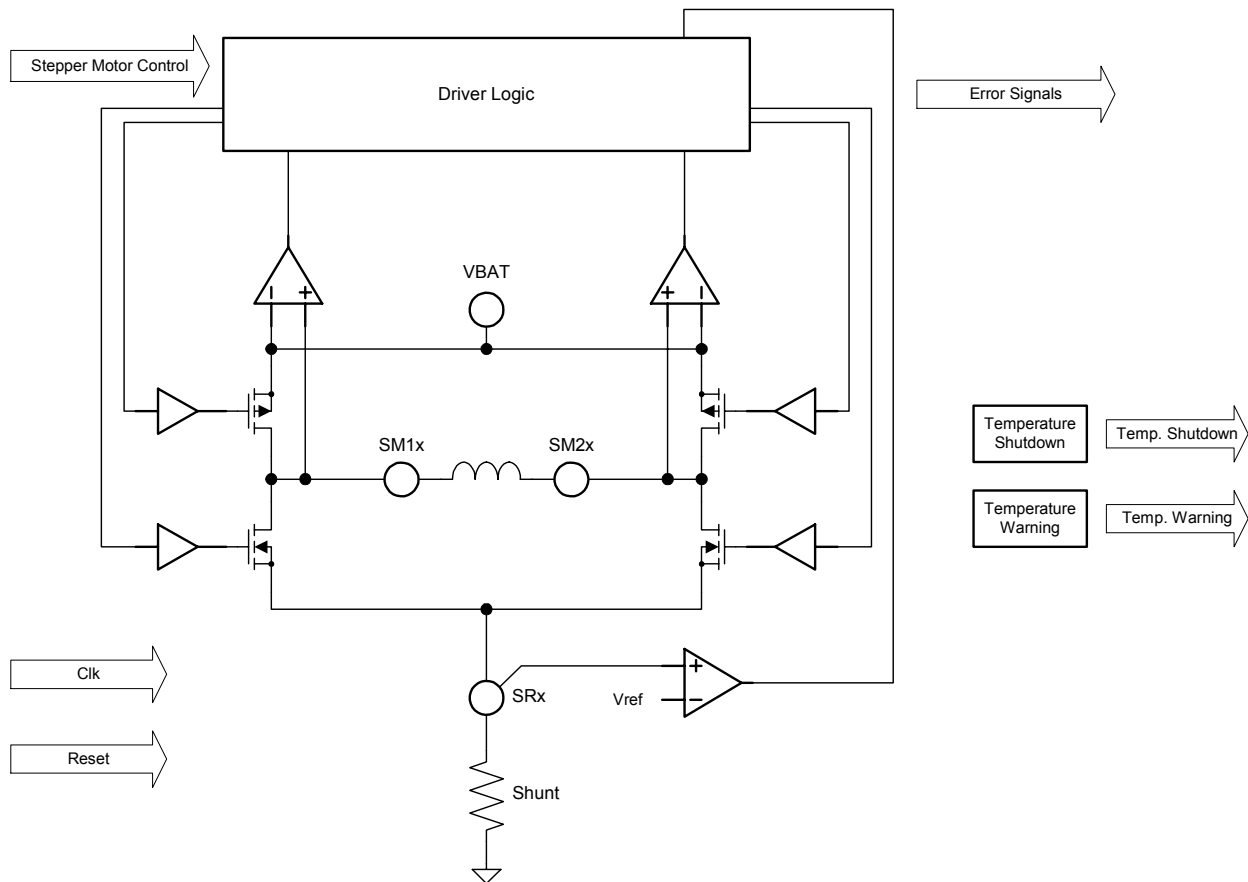


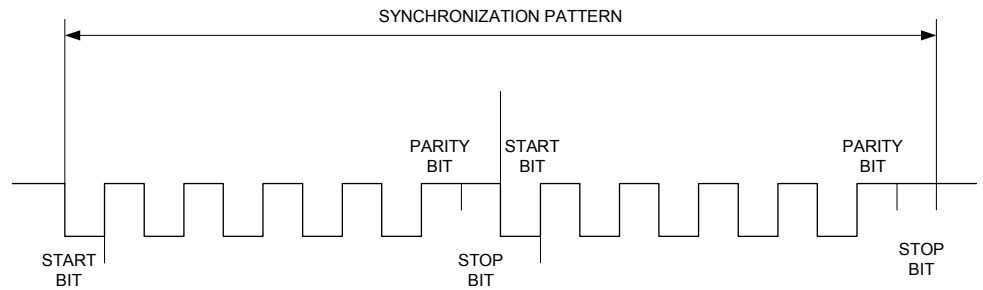
Figure 5 shows the diagram of one H-bridge driver stage. It consists of two NMOS and two PMOS power transistors. An external shunt is used for measuring the current flowing through the motor coil. Additional comparators and current sensing circuitry is integrated for error detection.

## Data Communication

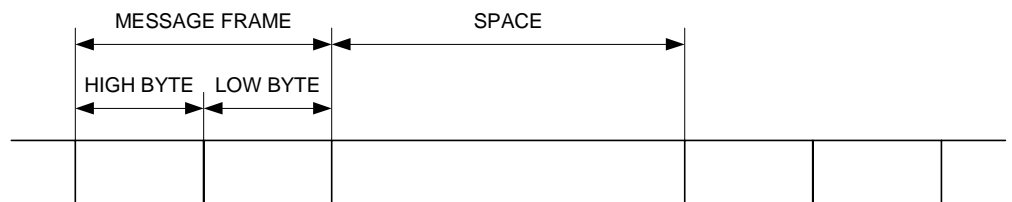
The circuit receives all commands for the stepping motor via a single wire bus. In idle mode the bus pin is pulled up by an internal current source near to VBAT voltage. During the transmission the external transmitter has to pull down the bus level to send information about data and clock timing. The used baud rate has to be about 2400 baud. Because of oscillator tolerances a synchronization sequence has to be sent at the beginning of data transfer.

Figure 6 shows the pattern used for this sequence. The circuit uses the 1-0-1-0 sequences for adjusting the internal bit time. Later on during data transfer every 1-0-1-0 sequence coming up randomly is used for resynchronization. Thus all tolerances that occur during operation will be eliminated.

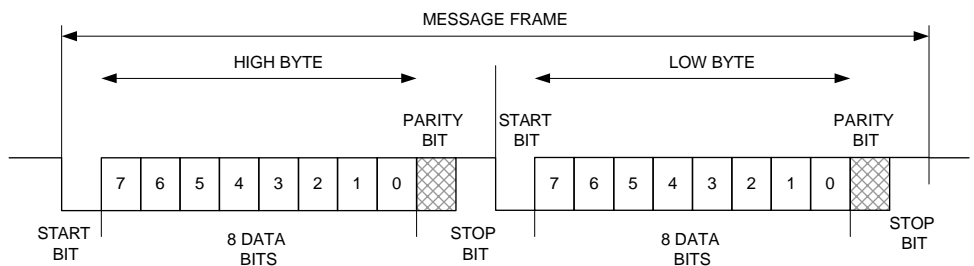
To obtain a synchronization of up to 15% oscillator tolerance the pattern has to be sent at least 4 times.

**Figure 6.** Synchronization Sequence

Between two commands a pause has to be included. This is necessary for a clear recognition of a new message frame (command). Figure 7 shows the timing diagram of two commands.

**Figure 7.** Message Frame and Space

Every command consists of 16 bits. They will be sent with two bytes. Figure 8 shows the message frame. The high byte is sent first, immediately followed by the low byte. Every byte starts with a start bit and ends with a parity bit and a stop bit. The first start bit (level 0) after a pause (level 1) indicates the beginning of a new message frame. The value of the parity bit has to be odd, i.e., the crossfooting of the byte including the parity bit is odd. If a data packet is not recognized due to a transmission error (parity error), the entire command is rejected.

**Figure 8.** Command Bits

## Bus Commands

There are different commands for controlling the stepping motor. Table 1 shows a list of all implemented commands and their meanings. The first command, the synchronization sequence, is described above. The second group of commands are the reference commands. A reference run command causes the stepping motor to make an initial run. It is used to establish a defined start position for the following position commands. The way the reference run is executed will be described later. There are two reference run commands. The difference is the turn direction of the stepping motor. This makes the circuit more flexible for different applications. The turn direction is coded in the 4 identifier bits.

**Table 1.** Bus Commands

Bus Command	High Byte								Low Byte							
	Data		Mode		Identifier				Data							
	7	6	5	4	3	2	1	0	7	6	5	4	3	2	1	0
Synchronization	1	0	1	0	1	0	1	0	1	0	1	0	1	0	1	0
Reference run (extend)	0	0	0	0	1	0	0	1	0	0	0	0	0	0	0	0
Reference run (retract)	0	0	0	0	0	1	1	0	0	0	0	0	0	0	0	0
New position (0 = full extension)	D8	D9	0	0	1	0	0	1	D0	D1	D2	D3	D4	D5	D6	D7
New position (0 = full retraction)	D8	D9	0	0	0	1	1	0	D0	D1	D2	D3	D4	D5	D6	D7
New position (testmode, 0 = full extension)	D8	D9	1	1	1	0	0	1	D0	D1	D2	D3	D4	D5	D6	D7
New position (testmode, 0 = full retraction)	D8	D9	1	1	0	1	1	0	D0	D1	D2	D3	D4	D5	D6	D7

The last class of commands are the position commands. Every new position will be sent as an absolute value. This makes the transmission more safe in terms of losing a position command. The next received command tells the stepping motor the right position again. For the position data there are 10 bits available (D0 to D9).

The maximum possible step count to be coded with 10 bit is 1024. Though position commands up to 1024 will be executed, it's prohibited to use values higher than 698, as this is the step count of the reference run. For details see chapter "Reference Run".

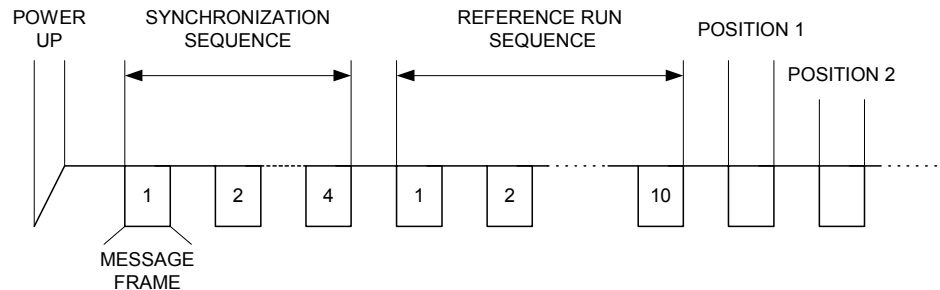
There are 4 new position commands. They differ in the identifier and in the modus bits. The identifier fixes the turn direction. For test purposes there are new position commands with a different mode. In this mode the stepping motor works with a reduced coil current. This may be used for end tests in the production of the application.

Any command with modus or identifier different to the first reference run will be ignored. Thus it is also not possible to change modus or identifier by performing a second reference run.

## Power-up Sequence

After power-up the circuit has to be synchronized and a reference run has to be executed before a position command can be carried out. Figure 9 shows a timing diagram on how the necessary sequences follow each other.

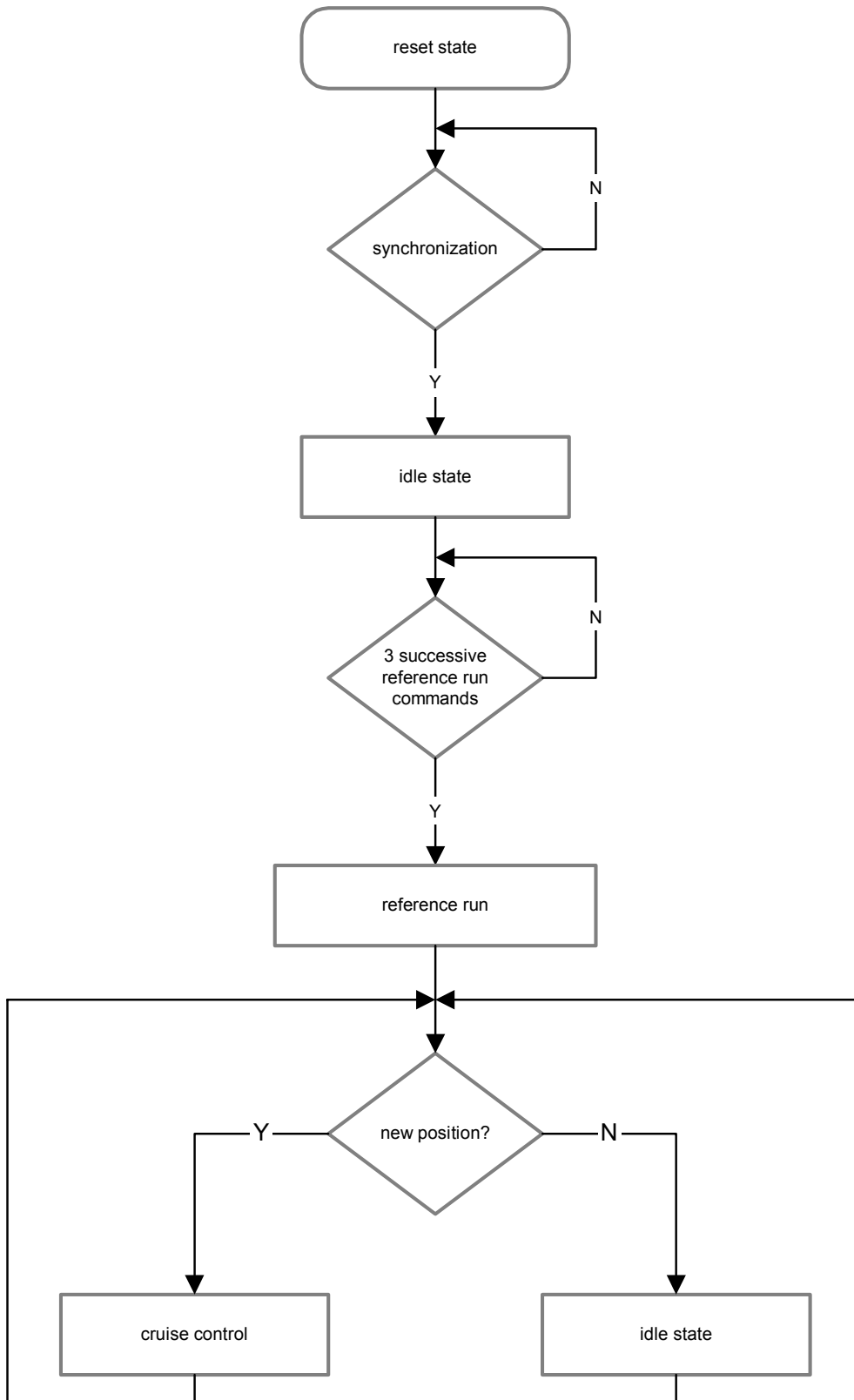
**Figure 9.** Power-up Sequence



The first sequence is the synchronization sequence. Its pattern (Figure 6) should be sent at least 4 times to be sure that the following commands will be recognized. If there are distortions on the bus it is helpful to send this sequence more than 4 times. A RC lowpass filter at the bus pin (Figure 16) helps to reduce distortions.

After synchronization the stepping motor has to make the reference run to initialize its zero position. The first reference run will only be executed if the circuit recognizes this command three times in series. This function is implemented contributing to the importance of the reference run. After the reference run the circuit will switch to normal operation. To perform a reference run during normal operation, the command has to be sent only once. Figure 10 shows the state diagram for the implemented sequence processor.

**Figure 10.** Flow Diagram for the Power-up Sequence



## Reference Run

In normal operation, new position commands are transmitted as absolute values. To drive the stepping motor to these absolute positions, the circuit has to know the motor's zero position. Therefore, the stepping motor has to perform a reference run after each power-up in which it is extended or retracted to its limit stop. Before the execution of the reference run, the motor is supplied with hold current.

As the actual position is not known at the beginning of the reference run the whole position range has to be passed. To optimize performance for smaller actuators, the reference run has been reduced to 698 steps. Therefore, it is prohibited to access positions higher than 698, because in a following reference run the stepping motor would not reach its zero position.

If it is necessary that the entire range up to position 1024 can be used, the reference run has to be executed twice. Since any command during reference run is ignored, the second reference command has to be sent about 2.4 s after the first command.

To avoid any possible mistake, e.g., the loss of a step during the reference run or the bouncing at the limit stop, there is a special run to be executed. This is shown in Table 2.

**Table 2.** Reference Run Course

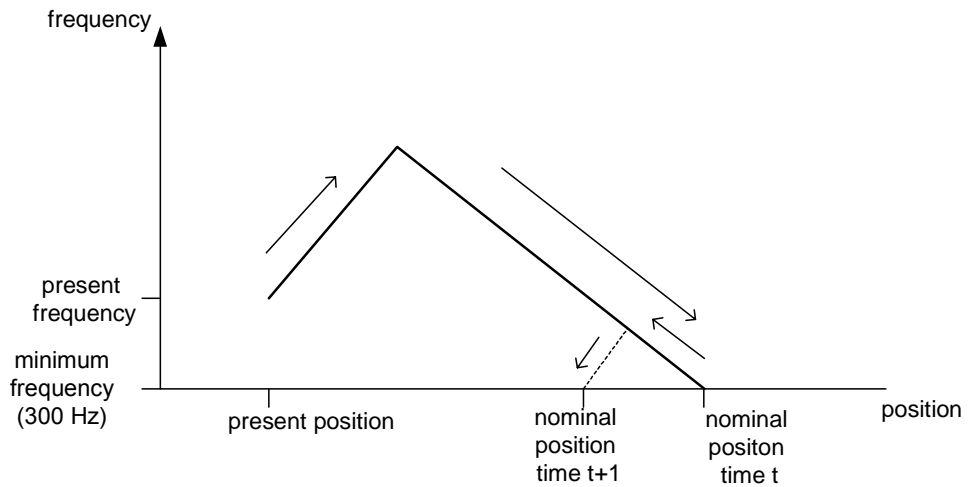
Phase	Action		Int. Counter	Step time
I	Ramp up to 446 Hz step frequency	Drive through the whole range (698 steps)	704	3300 $\mu$ s
			703	2895 $\mu$ s
			702	2540 $\mu$ s
			701	2240 $\mu$ s
	Drive at constant speed		700 to 11	2240 $\mu$ s
	Ramp down to minimum step frequency (303 Hz)		10	2240 $\mu$ s
			9	2549 $\mu$ s
II			8	2895 $\mu$ s
III			7 to 6	3300 $\mu$ s
IV	Wait for $6 \times 3300 \mu$ s with the last coil current		6	3300 $\mu$ s
V	Perform another 6 steps with 3300 $\mu$ s		5 to 0	3300 $\mu$ s
VI	Wait for $5 \times 3300 \mu$ s with the last coil current		0	3300 $\mu$ s
VII	Set current to hold current; normal operation		varied	varied

## Cruise Control

The travel operation control independently moves the stepping motor into its new position. To reach the new position as fast as possible but without abrupt velocity changes, the stepping motor is accelerated or slowed down depending on the difference between actual and nominal position. If this difference is huge the stepping frequency will increase (acceleration). When the new position is nearly reached, the frequency will decrease again (deceleration). In the case of a new nominal position opposite to the direction of the motion being from the microcontroller, the stepping frequency will decrease to its starting value (300 Hz) before the direction can turn. The cruise control is shown in Figure 11.

The possible stepping frequencies for velocity control are shown in Table 3.

**Figure 11. Cruise Control**



**Table 3. Frequency Ramp**

Number	Step Frequency (Hz)	Step Time ( $\mu$ s)
1	303	3300
2	345	2895
3	394	2540
4	446	2240
5	493	2030
6	583	1860
7	575	1740
8	673	1630
9	649	1540
10	680	1470
11	714	1400
12	741	1350
13	769	1300
14	800	1250
15	826	1210
16	855	1170
17	877	1140
18	901	1110
19	926	1080
20	952	1050
21	980	1020
22	1000	1000

In addition to the actual step frequency there is a maximum step frequency up to which the actual step frequency can rise. To secure a correct operation at low supply voltages the maximum value for the stepping frequency is smaller at low voltages. If the supply voltage falls below the 9 V threshold, travel operation will suspend. To restart operation, the supply voltage has to rise above 10.5 V. The relation of the maximum step frequency and the supply voltage during operation is shown in Table 4.

If the chip temperature exceeds the overtemperature warning threshold, the step speed is reduced to 300 Hz. If the chip temperature rises further the output driver is shut off.

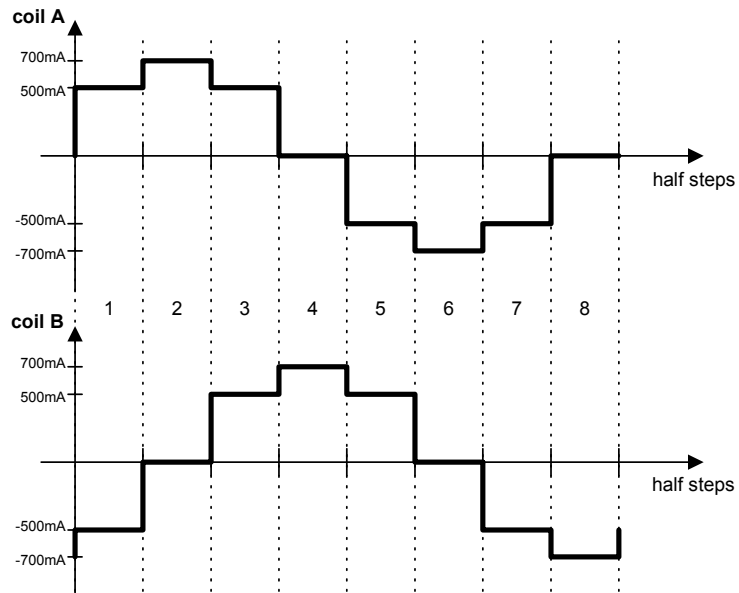
**Table 4.** Maximum Step Frequency

$V_{BAT}$	Maximum Step Frequency at Rising Voltage	Maximum Step Frequency ( $V_{BAT}$ once > 10.5 V)
< 9 V	No operation	No operation
9 V to 9.5 V	No operation	300 Hz (3.33 ms)
9.5 V to 10 V	No operation	500 Hz (2.03 ms)
10 V to 10.5 V	No operation	680 Hz (1,47 ms)
10.5 V to 11 V	850 Hz (1.17 ms)	850 Hz (1.17 ms)
> 11 V	1000 Hz (1 ms)	1000 Hz (1 ms)
> 20 V	No operation	No operation

## Step Operation

The stepping motor is operated in halfstep-compensation mode. The current for both coils is shown in Figure 12. The current levels are increased when the temperature is below 0°C to secure operation. For final tests at the end of the application production line the currents are reduced.

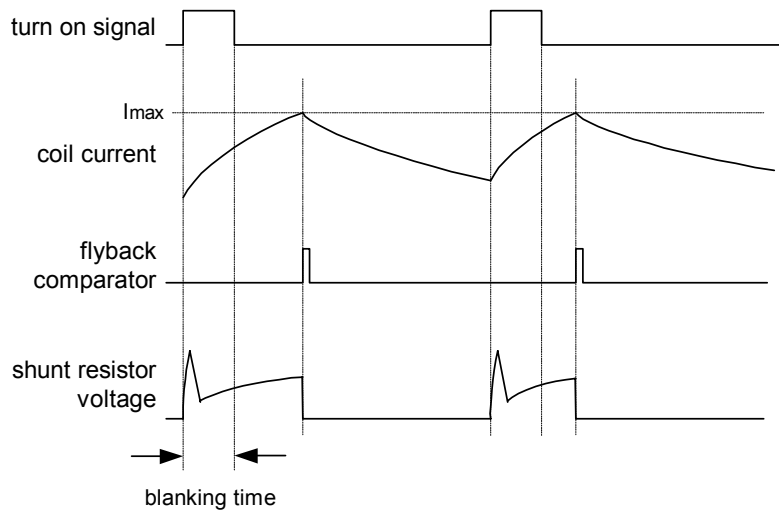
**Figure 12.** Compensated Halfstep Operation



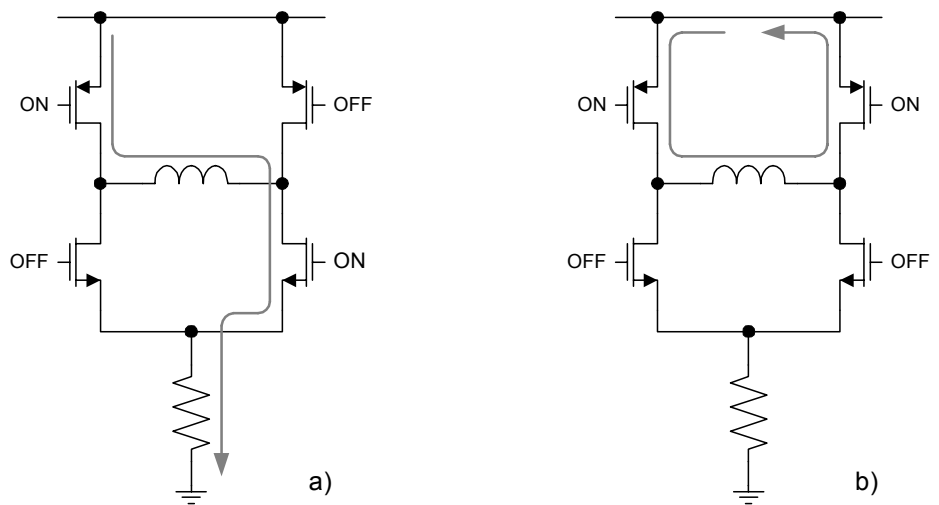
## Chopper Current Control

The chopper current control is shown in Figure 13. The current is turned on every 40  $\mu$ s (25 kHz chopper frequency). The current flow in the H-bridge is shown in Figure 14a. After a blanking time of 2.5  $\mu$ s to suppress turn-on peaks the current is measured via the shunt voltage. As soon as the current has reached its nominal value it is turned off again. The current flow in this state is shown in Figure 14b.

**Figure 13. Chopper Current Control**



**Figure 14. Current Flow in Halfbridge**



## Exception Handling

During operation, different exceptional states or errors can arise to which the circuit must correspondingly react. These are described below:

- Supply voltage below 9 V

Travel operation is suspended for the duration of the undervoltage. The output current will be set to zero. When the supply voltage rises above 10.5 V, travel operation restarts.

- Supply voltage above 20 V

Travel operation is suspended for the duration of the undervoltage. The output current will be set to zero. When the supply voltage falls below 20 V, travel operation restarts.

- Overtemperature warning

The maximum stepping speed is reduced to 300 Hz. This ensures a safe shut-off procedure if the temperature increases to shut-off temperature.

- Overtemperature shut-off

Travel operation is suspended when overtemperature is detected. An error signal is sent to the bus master via the bus. Operation can only restart after the supply voltage is shut off.

- Interruption of a stepping motor winding

The motor windings are only checked for interruption when supplied with hold current, not during drive operation. The corresponding output is shut off. The other coil winding is supplied with hold current. An error signal is sent. Operation can only restart after the supply voltage is shut off.

- Short circuit of a stepping motor winding

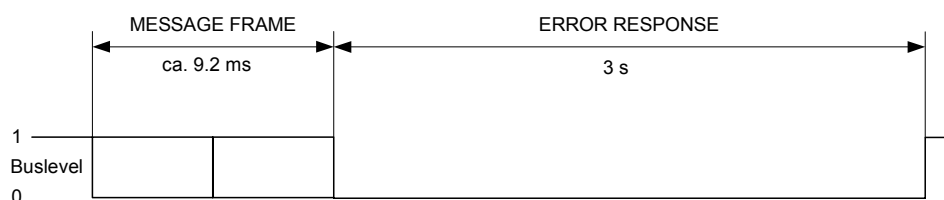
The corresponding output is shut off. The other coil winding is supplied with hold current. An error signal is sent. Operation can only restart after the supply voltage is shut off.

- Short circuit of an output to ground or  $V_{BAT}$

The corresponding output is shut off. The other coil winding is supplied with hold current. An error signal is sent. Operation can only restart after the supply voltage is shut off.

An error signal is sent to the microcontroller by clamping the bus to ground for 3 seconds. If the error should occur during a data transmission, the above described reactions will happen immediately except for the clamping. This will take place about 200  $\mu$ s after the end of the stopbit of the lowbyte to guarantee a correct command recognition in the second headlamp. The error signal timing is shown in Figure 15.

**Figure 15.** Error Signal Timing



## Absolute Maximum Ratings

Parameters	Symbol	Value	Unit
Power supply ( $t < 400$ ms)	$V_{BAT}$	-0.3 to +45	V
DC power supply	$V_{BAT}$	-0.3 to +28	V
DC output current	$I_{OUT}$	$\pm 1.1$	A
BUS input voltage	$V_{BUS}$	-0.3 to $V_{BAT} + 0.3$	V
Human body model	ESD	2	kV
Charged device model	ESD	500	V
Storage temperature	$T_{Stg}$	-55 to +150	$^{\circ}$ C
Operating temperature	$T_{op}$	-40 to +105	$^{\circ}$ C
Maximum junction temperature	$T_{jmax}$	+150	$^{\circ}$ C

## Thermal Resistance

Parameters	Symbol	Value	Unit
Thermal resistance junction-case	$R_{thJC}$	5	K/W
Thermal resistance junction-ambient	$R_{thJA}$	35	K/W

## Operating Range

Parameters	Symbol	Value	Unit
Power supply range	$V_{BAT}$	7 to 20	V
Operating temperature range	$T_{op}$	-40 to +105	°C

## Electrical Characteristics

No.	Parameters	Test Conditions	Pin	Symbol	Min.	Typ.	Max.	Unit	Type*
<b>1</b>	<b>Supply</b>								
1.1	Supply current	$V_{BAT} = 14\text{ V}$ (no motor current)	1, 7, 15, 21	$I_{total}$		4	7	mA	A
1.2	Supply voltage	Normal operation	1, 7, 15, 21	$V_{BATsup}$	7.0		20	V	C
1.3	$V_{DD}$ voltage		23	$V_{VDD\_13V}$	4.9	5.0	5.1	V	A
1.4	$V_{DD}$ voltage	$V_{BAT} = 7.0\text{ V}$	23	$V_{VDD\_7V}$	4.8	5.0	5.1	V	A
<b>2</b>	<b>Bus Port</b>								
2.1	Threshold voltage	$V_{BAT} = 12.0\text{ V}$ , rising edge	22	$V_{LH\_BUS\_12}$	5.5	6.5	7.5	V	A
2.2	Threshold voltage	$V_{BAT} = 12\text{ V}$ , falling edge	22	$V_{HL\_BUS\_12}$	4.5	5.5	6.5	V	A
2.3	Hysteresis		22	$V_{HYS\_BUS12}$		1		V	A
2.4	Input current	$V_{BUS} = 0\text{ V}$	22	$I_{OUT\_BUS\_8}$	-400	-300	-220	μA	A
2.5	Saturation voltage	$I_{BUS} = 2\text{ mA}$ , bus clamping	22	$V_{SAT\_BUS\_7}$			0.5	V	A
2.6	Pulldown current	At error condition	22	$I_{Pulldwn\_7}$	2			mA	A
<b>3</b>	<b>Oscillator</b>								
3.1	Frequency	$COS = 100\text{ pF} \pm 5\%$ $RSET = 20\text{ k}\Omega \pm 1\%$	27	$F_{OSC\_13}$	340	400	460	kHz	A
<b>4</b>	<b>Reference</b>								
4.1	Reference voltage	$RSET = 20\text{ k}\Omega \pm 1\%$	26	$V_{RSET\_13V}$	2.4	2.5	2.6	V	A
4.2	Reference voltage	$V_{BAT} = 7\text{ V}$	26	$V_{RSET\_7V}$	2.3	2.5	2.6	V	A
<b>5</b>	<b>Full Bridges</b>								
5.1	$R_{DSon}$	$R_{DSon}$ of half-bridge	3, 5, 17, 20	$R_{DSon}$		1.2	1.7	Ω	A

\*) Type means: A = 100% tested, B = 100% correlation tested, C = Characterized on samples, D = Design parameter

Note: 1. cmd = command

## Electrical Characteristics (Continued)

No.	Parameters	Test Conditions	Pin	Symbol	Min.	Typ.	Max.	Unit	Type*
5.2	Output current	Output stage off	3, 5, 17, 20	$I_{LEAK}$			10	$\mu A$	A
5.3	Output current	Hold mode	3, 5, 17, 20	$V_{SHUNT18}$	40	55	200	mA	B
5.4	Output current	Test mode	3, 5, 17, 20	$V_{SHUNT99}$	240	300	360	mA	B
5.5	Output current	Normal mode	3, 5, 17, 20	$V_{SHUNT182}$	500	550	600	mA	B
5.6	Output current	Normal mode ( $T < 0^{\circ}C$ )	3, 5, 17, 20	$V_{SHUNT128}$	600	660	720	mA	B
5.7	Output current	Halfstep compensation	3, 5, 17, 20	$V_{SHUNT257}$	700	780	860	mA	B
5.8	Output current	Halfstep comp- ensation ( $T < 0^{\circ}C$ )	3, 5, 17, 20	$V_{SHUNT309}$	840	936	1040	mA	B
5.9	Overcurrent threshold	Highside switch	3, 5, 17, 20	$I_{OC\_H}$		1.6		A	A
5.10	Overcurrent threshold	Lowside switch	3, 5, 17, 20	$I_{OC\_L}$		1.6		A	B
5.11	Chopper frequency					1/16		fcos	D
<b>6</b>	<b>Voltage Comparators</b>								
6.1	Threshold voltage	9.0 V comparator, rising edge	1, 7, 15, 21	$V_{9\_UP}$	8.8	9.1	9.4	V	A
6.2	Threshold voltage	9.0 V comparator, falling edge	1, 7, 15, 21	$V_{9\_DOWN}$	8.6	8.9	9.2	V	A
6.3	Hysteresis	9.0 V comparator	1, 7, 15, 21	$V_{9\_HYS}$	60	200	340	mV	A
6.4	Threshold voltage	9.5 V comparator, rising edge	1, 7, 15, 21	$V_{9\_5\_UP}$	9.3	9.6	9.9	V	A
6.5	Threshold voltage	9.5 V comparator, falling edge	1, 7, 15, 21	$V_{9\_5\_DOWN}$	9.1	9.4	9.7	V	A
6.6	Hysteresis	9.5 V comparator	1, 7, 15, 21	$V_{9\_5\_HYS}$	60	200	340	mV	A
6.7	Threshold voltage	10.0 V comparator, rising edge	1, 7, 15, 21	$V_{10\_UP}$	9.8	10.1	10.4	V	A
6.8	Threshold voltage	10.0 V comparator, falling edge	1, 7, 15, 21	$V_{10\_DOWN}$	9.6	9.9	10.2	V	A
6.9	Hysteresis	10.0 V comparator	1, 7, 15, 21	$V_{10\_HYS}$	60	200	340	mV	A
6.10	Threshold voltage	10.5 V comparator, rising edge	1, 7, 15, 21	$V_{10\_5\_UP}$	10.35	10.65	10.95	V	A
6.11	Threshold voltage	10.5 V comparator, falling edge	1, 7, 15, 21	$V_{10\_5\_DOWN}$	10.15	10.45	10.75	V	A
6.12	Hysteresis	10.5 V comparator	1, 7, 15, 21	$V_{10\_5\_HYS}$	60	200	340	mV	A

\*) Type means: A = 100% tested, B = 100% correlation tested, C = Characterized on samples, D = Design parameter

Note: 1. cmd = command



## Electrical Characteristics (Continued)

No.	Parameters	Test Conditions	Pin	Symbol	Min.	Typ.	Max.	Unit	Type*
6.13	Threshold voltage	11.0 V comparator, rising edge	1, 7, 15, 21	V <sub>11_UP</sub>	10.8	11.1	11.4	V	A
6.14	Threshold voltage	11.0 V comparator, falling edge	1, 7, 15, 21	V <sub>11_DOWN</sub>	10.6	10.9	11.2	V	A
6.15	Hysteresis	11.0 V comparator	1, 7, 15, 21	V <sub>11_HYS</sub>	60	200	340	mV	A
6.16	Threshold voltage	20.0 V comparator, rising edge	1, 7, 15, 21	V <sub>20_UP</sub>	19.7	20.2	20.7	V	A
6.17	Threshold voltage	20.0 V comparator, falling edge	1, 7, 15, 21	V <sub>20_DOWN</sub>	19.25	19.75	20.25	V	A
6.18	Hysteresis	20.0 V comparator	1, 7, 15, 21	V <sub>20_HYS</sub>	200	450	750	mV	A
6.19	Threshold voltage	Motor disable (falling voltage)	1, 7, 15, 21	V <sub>9_DOWN</sub>	8.6	8.9	9.2	V	A
6.20	Threshold voltage	Motor enable (rising voltage)	1, 7, 15, 21	V <sub>10.5_UP</sub>	10.35	10.65	10.95	V	A
6.21	Hyteresis	Undervoltage turn off	1, 7, 15, 21	M <sub>DIS_HYS</sub>	1.3	1.7	2.1	V	A
6.22	Distance	9.5 V to 9 V comparator rising edges	1, 7, 15, 21	D <sub>9.5-9_R</sub>	300	500	700	mV	A
6.23	Distance	9.5 V to 9 V comparator falling edges	1, 7, 15, 21	D <sub>9.5-9F</sub>	300	500	700	mV	A
6.24	Distance	10 V to 9.5 V comparator rising edges	1, 7, 15, 21	D <sub>10-9.5R</sub>	300	500	700	mV	A
6.25	Distance	10 V to 9.5 V comparator falling edges	1, 7, 15, 21	D <sub>10-9.5F</sub>	300	500	700	mV	A
6.26	Distance	10.5 V to 10 V comparator rising edges	1, 7, 15, 21	D <sub>10.5-10R</sub>	300	500	700	mV	A
6.27	Distance	10.5 V to 10 V comparator falling edges	1, 7, 15, 21	D <sub>10.5-10F</sub>	300	500	700	mV	A
6.28	Distance	11 V to 10.5 V comparator rising edges	1, 7, 15, 21	D <sub>11-10.5R</sub>	300	500	700	mV	A
6.29	Distance	11 V to 10.5 V comparator falling edges	1, 7, 15, 21	D <sub>11-10.5F</sub>	300	500	700	mV	A
<b>7</b>	<b>Timing</b>								
7.1	Baud rate	f <sub>cos</sub> = 340 to 460 kHz, full synchronization	22	Baud	2350	2400	2450	Baud	C, D

\*) Type means: A = 100% tested, B = 100% correlation tested, C = Characterized on samples, D = Design parameter

Note: 1. cmd = command

## Electrical Characteristics (Continued)

No.	Parameters	Test Conditions	Pin	Symbol	Min.	Typ.	Max.	Unit	Type*
7.2	Delay time	2 following commands	22	$T_D$	5			ms	C, D
7.3	Pause time	Between high and low byte	22	$T_P$			0	$\mu$ s	C, D
7.4	Clamping time	Bus error clamping	22	$T_{cl}$		3		s	C, D
<b>8</b>	<b>Logic</b>								
8.1	Reference run detection	Commands in series to execute first reference run		Ref3	3	3	3	cmd <sup>(1)</sup>	D
8.2	Synchronization	15% oscillator tolerance		Sync	4			cmd <sup>(1)</sup>	D
<b>9</b>	<b>Thermal Values</b>								
9.1	Thermal prewarning			$T_{150}$		150		$^{\circ}$ C	B
9.2	Hysteresis	Thermal prewarning		$T_{150_{HYS}}$		10		$^{\circ}$ C	B
9.3	Thermal shut down			$T_{160}$		160		$^{\circ}$ C	B
9.5	Thermal current boost			$T_0$		0		$^{\circ}$ C	B
9.6	Hysteresis	Thermal current boost		$T_0_{HYS}$		10		$^{\circ}$ C	B

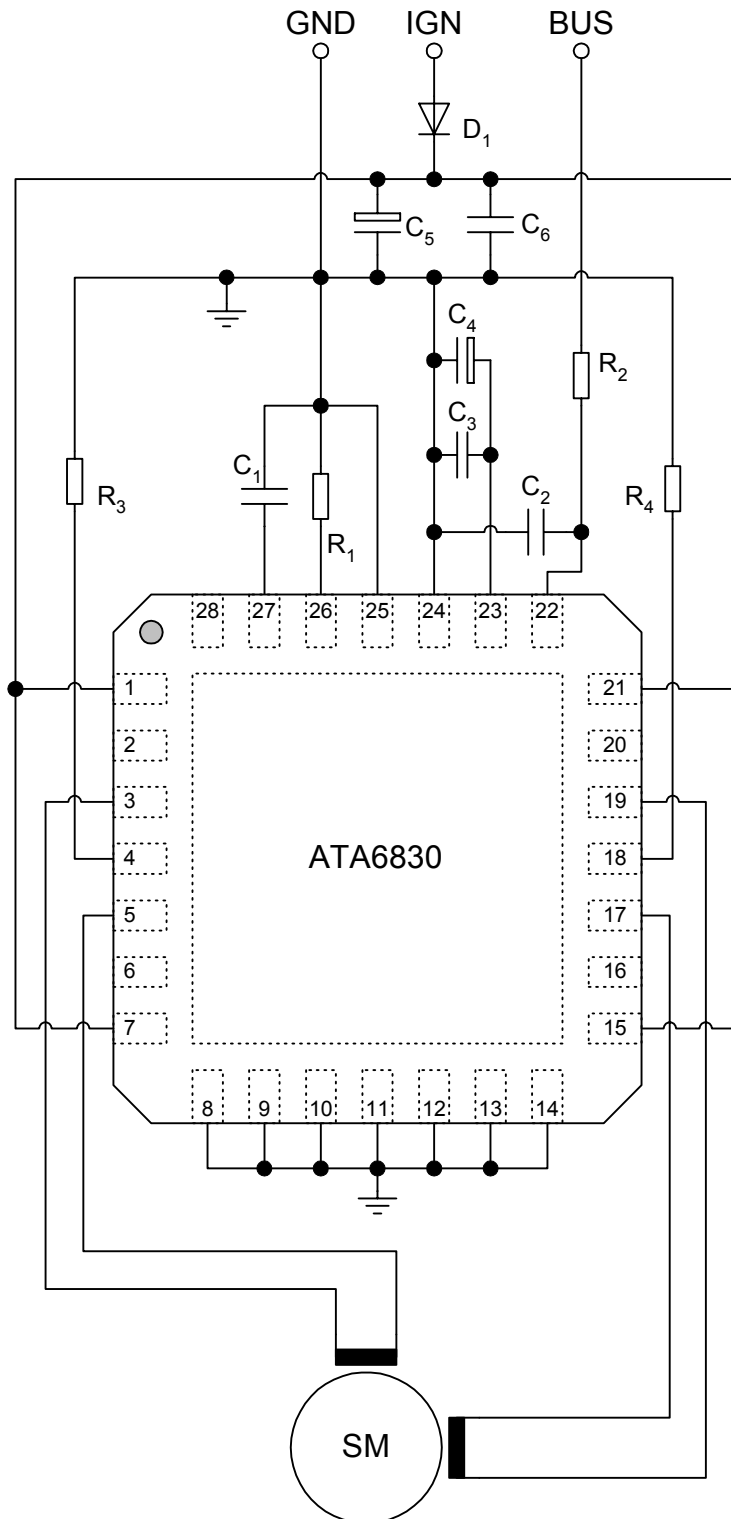
\*) Type means: A = 100% tested, B = 100% correlation tested, C = Characterized on samples, D = Design parameter

Note: 1. cmd = command

## Soldering Recommendations

Parameters	Symbol	Value	Unit
Maximum heating rate	$T_D$	1 to 3	$^{\circ}$ C/s
Peak temperature in preheat zone	$T_{PH}$	100 to 140	$^{\circ}$ C
Duration of time above melting point of solder	$t_{MP}$	minimum 10 maximum 75	s
Peak reflow temperature	$T_{Peak}$	220 to 225	$^{\circ}$ C
Maximum cooling rate	$T_{Peak}$	2 to 4	$^{\circ}$ C/s

Figure 16. Application Circuit



**Table 5.** Bill of Material

Reference	Component	Value
C1	Oscillator capacitor	100 pF, 5%
C2	Bus input capacitor	1 nF
C3	Ceramic capacitor	100 nF
C4	Capacitor	10 $\mu$ F
C5	Capacitor	100 $\mu$ F
C6	Capacitor	100 nF
D1	Rectifier	–
R1	Reference resistor	20 k $\Omega$ , 1%
R2	Bus input resistor	1 k $\Omega$ , 5%
R3	Shunt resistor side A	0.24 $\Omega$ , 5%
R4	Shunt resistor side A	0.24 $\Omega$ , 5%

## Ordering Information

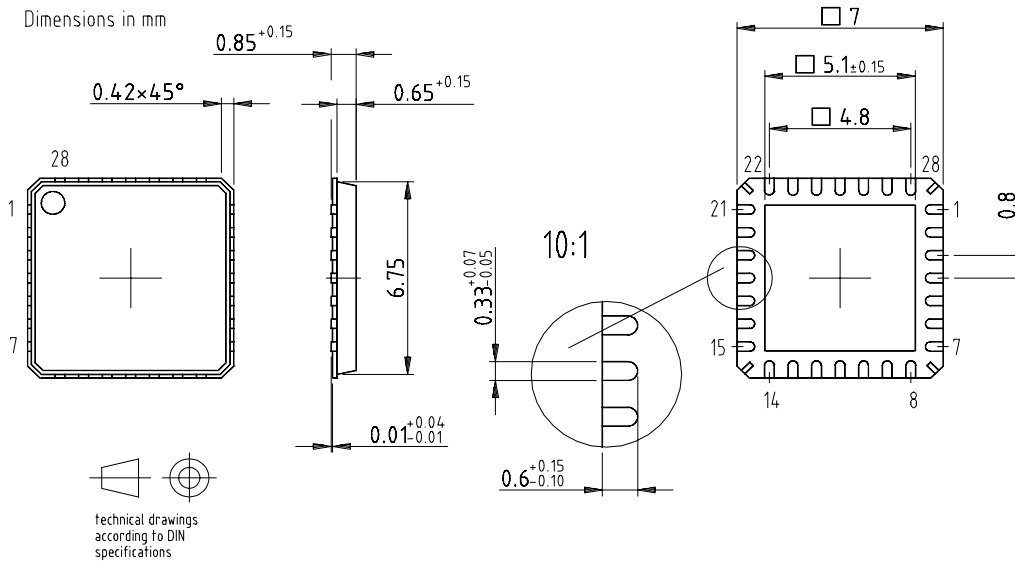
Extended Type Number	Package	Remarks
ATA6830-PKQ	HP-VFQFP-N28	7 mm × 7 mm

## Package Information

The package is a thermal power package MLF 7 × 7 with a soldered leadframe and 28 pins. The overall size is 7 × 7 mm<sup>2</sup>.

Package: HP-VFQFP-N28  
 Exposed pad Var. C  
 (acc. JEDEC OUTLINE No. MO-220)

Dimensions in mm



Drawing-No.: 6.543-5073.01-4  
 Issue: 2; 08.04.02



## Atmel Headquarters

### *Corporate Headquarters*

2325 Orchard Parkway  
San Jose, CA 95131  
TEL 1(408) 441-0311  
FAX 1(408) 487-2600

### *Europe*

Atmel Sarl  
Route des Arsenaux 41  
Case Postale 80  
CH-1705 Fribourg  
Switzerland  
TEL (41) 26-426-5555  
FAX (41) 26-426-5500

### *Asia*

Room 1219  
Chinachem Golden Plaza  
77 Mody Road Tsimhatsui  
East Kowloon  
Hong Kong  
TEL (852) 2721-9778  
FAX (852) 2722-1369

### *Japan*

9F, Tonetsu Shinkawa Bldg.  
1-24-8 Shinkawa  
Chuo-ku, Tokyo 104-0033  
Japan  
TEL (81) 3-3523-3551  
FAX (81) 3-3523-7581

## Atmel Operations

### *Memory*

2325 Orchard Parkway  
San Jose, CA 95131  
TEL 1(408) 441-0311  
FAX 1(408) 436-4314

### *Microcontrollers*

2325 Orchard Parkway  
San Jose, CA 95131  
TEL 1(408) 441-0311  
FAX 1(408) 436-4314

La Chantrerie  
BP 70602  
44306 Nantes Cedex 3, France  
TEL (33) 2-40-18-18-18  
FAX (33) 2-40-18-19-60

### *ASIC/ASSP/Smart Cards*

Zone Industrielle  
13106 Rousset Cedex, France  
TEL (33) 4-42-53-60-00  
FAX (33) 4-42-53-60-01

1150 East Cheyenne Mtn. Blvd.  
Colorado Springs, CO 80906  
TEL 1(719) 576-3300  
FAX 1(719) 540-1759

Scottish Enterprise Technology Park  
Maxwell Building  
East Kilbride G75 0QR, Scotland  
TEL (44) 1355-803-000  
FAX (44) 1355-242-743

### *RF/Automotive*

Theresienstrasse 2  
Postfach 3535  
74025 Heilbronn, Germany  
TEL (49) 71-31-67-0  
FAX (49) 71-31-67-2340

1150 East Cheyenne Mtn. Blvd.  
Colorado Springs, CO 80906  
TEL 1(719) 576-3300  
FAX 1(719) 540-1759

### *Biometrics/Imaging/Hi-Rel MPU/ High Speed Converters/RF Datacom*

Avenue de Rochepleine  
BP 123  
38521 Saint-Egreve Cedex, France  
TEL (33) 4-76-58-30-00  
FAX (33) 4-76-58-34-80

---

### *e-mail*

literature@atmel.com

### *Web Site*

<http://www.atmel.com>

### © Atmel Corporation 2002.

Atmel Corporation makes no warranty for the use of its products, other than those expressly contained in the Company's standard warranty which is detailed in Atmel's Terms and Conditions located on the Company's web site. The Company assumes no responsibility for any errors which may appear in this document, reserves the right to change devices or specifications detailed herein at any time without notice, and does not make any commitment to update the information contained herein. No licenses to patents or other intellectual property of Atmel are granted by the Company in connection with the sale of Atmel products, expressly or by implication. Atmel's products are not authorized for use as critical components in life support devices or systems.

Atmel® is the registered trademark of Atmel.

Other terms and product names may be the trademarks of others.



Printed on recycled paper.