

DO NOT SCALE FROM THIS PRINT

THIS PRODUCT MANUFACTURED WITH LEAD-FREE PROCESSING

DESIGNED & DIMENSIONED IN MILLIMETERS [INCHES]

SSMB-P-C-XX-ST-CA2

GENDER
-P: PLUG

TYPE
-C: CABLE

TERMINATION
-CA2: RG178U CABLE

ORIENTATION
-ST: STRAIGHT

PLATING SPECIFICATION
-HG: 30µ" GOLD CENTER CONTACT,
10µ" GOLD OUTER CONTACT
-GF: 10µ" GOLD CENTER CONTACT,
3µ" GOLD OUTER CONTACT
(SEE TABLE 1)

TABLE 1			
ITEM	COMPONENT	-HG	-GF
1	FERRULE	MCX-FER-005-N	
3	SUB ASSEMBLY	SUB-SSMB-P-C-GN-ST-CA2	SUB-SSMB-P-C-FN-ST-CA2
4	PIN	SSMB-P-C-H-ST-CA2-SKT	SSMB-P-C-G-ST-CA2-SKT

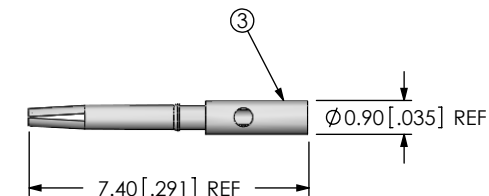
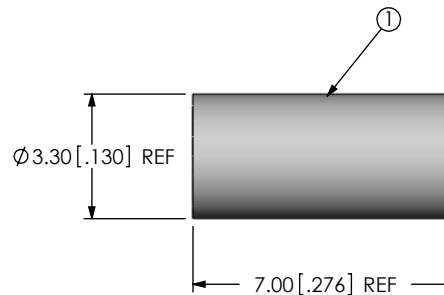
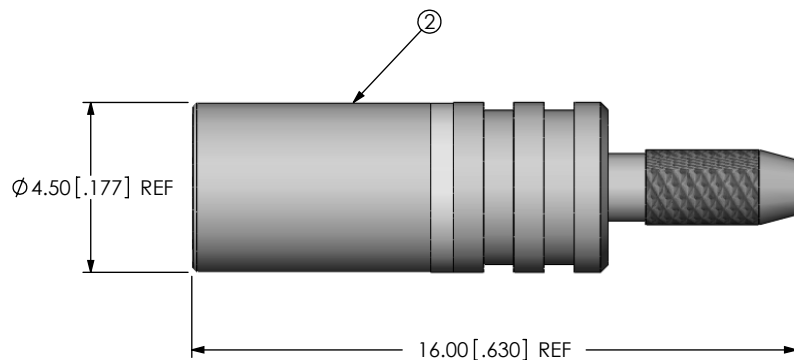

NOTES:

1. ⊗ REPRESENTS A CRITICAL DIMENSION.
2. DELETED.
3. PRODUCT TO BE PACKAGED PER PACKAGING STANDARD CO-HD-WI-3040-M. TRAY: TY-SMA001-1 COVER: TY-SMA001-2 200 PARTS PER TRAY (2 PARTS PER POCKET).
4. DELETED.
5. DELETED.
6. DELETED.
7. DELETED.
8. DELETED.

<p>UNLESS OTHERWISE SPECIFIED, DIMENSIONS ARE IN MILLIMETERS [INCHES]. TOLERANCES ARE:</p> <p>DECIMALS ANGLES</p> <p>.X: ± 0.3 [0.1] 5°</p> <p>.XX: ± 0.13 [0.05]</p> <p>.XXX: ± 0.051 [0.0020]</p>	<p>PROPRIETARY NOTE</p> <p>THIS DOCUMENT CONTAINS INFORMATION CONFIDENTIAL AND PROPRIETARY TO SAMTEC, INC. AND SHALL NOT BE REPRODUCED OR TRANSFERRED TO OTHER DOCUMENTS OR DISCLOSED TO OTHERS OR USED FOR ANY PURPOSE OTHER THAN THAT WHICH IT WAS OBTAINED WITHOUT THE EXPRESSED WRITTEN CONSENT OF SAMTEC, INC.</p>	<p>520 PARK EAST BLVD, NEW ALBANY, IN 47150 PHONE: 812-944-6733 FAX: 812-948-5047 e-Mail: info@SAMTEC.com code: 55322</p>
<p>BY: DUKES Z 11/8/2010</p>		<p>SHEET 1 OF 2</p>

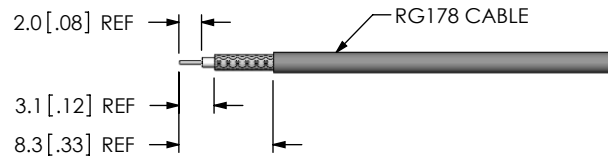

IN-PROCESS 1
STRIP AND TIN INNER CONDUCTOR

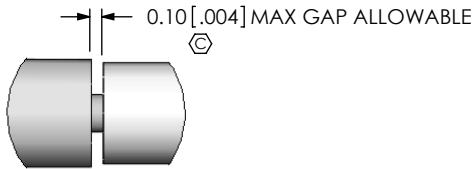

DETAIL 'B'
SCALE T6:1



IN-PROCESS 2
SOLDER SIGNAL SOCKET

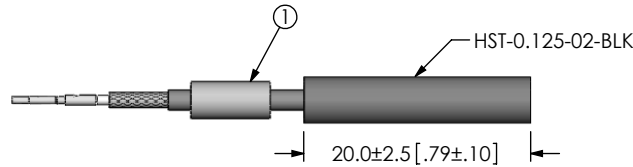

IN-PROCESS 3
ADD HEAT SHRINK TUBE AND FERRULE

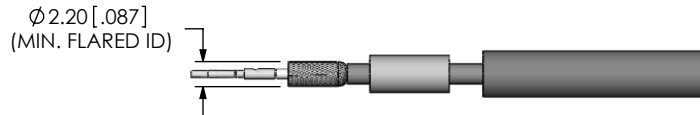

IN-PROCESS 4
FLARE SHIELD

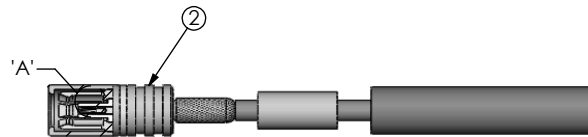

IN-PROCESS 5
ADD SUB ASSEMBLY

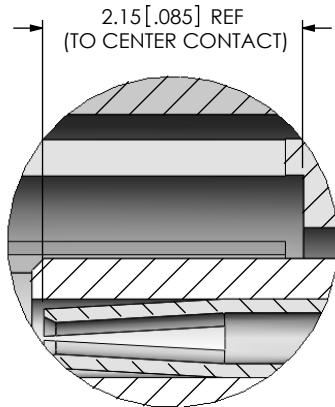

DETAIL 'A'
SCALE T6:1

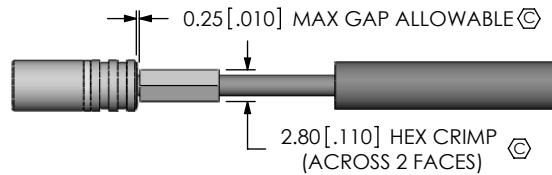

IN-PROCESS 6
CRIMP FERRULE
(USE RF CRIMP HAND TOOL # CAT-HT-126667-21 OR EQUIVALENT)
(USE .110" HEX DIE)

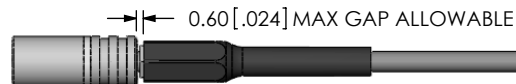

IN-PROCESS 7
APPLY HEAT SHRINK TUBING

PROPRIETARY NOTE

THIS DOCUMENT CONTAINS INFORMATION CONFIDENTIAL AND PROPRIETARY TO SAMTEC, INC. AND SHALL NOT BE REPRODUCED OR TRANSFERRED TO OTHER DOCUMENTS OR DISCLOSED TO OTHERS OR USED FOR ANY PURPOSE OTHER THAN THAT WHICH IT WAS OBTAINED WITHOUT THE EXPRESSED WRITTEN CONSENT OF SAMTEC, INC.

DO NOT SCALE DRAWING

SHEET SCALE: 3:2



520 PARK EAST BLVD, NEW ALBANY, IN 47150
PHONE: 812-944-6733 FAX: 812-948-5047
e-Mail: info@SAMTEC.com code: 55322

DESCRIPTION:
SSMB ST, CABLE, PLUG, RG178U 50 OHM

DWG. NO.
SSMB-P-C-XX-ST-CA2

BY: DUKES Z 11/8/2010 SHEET 2 OF 2