

XRD66L92



Low Voltage CMOS 12-Bit
High-Speed Analog-to-Digital Converter
with Serial Logic Interface Port

FEATURES

- 3.3 V Operation
- 12-Bit ADC with DNL = ± 1 LSB, INL = ± 2.5 LSB
- Sampling Frequency 1 MHz (typ)
- Rail-to-Rail Input Range
- V_{REF} Range: 1.5 V to V_{DD}
- CMOS Low Power: 25 mW (typ)
- Spaced Ladder Taps for Non-Linear Transfer Function Creation
- Binary and Two's Complement Digital Output Mode
- Serial Port
- Underflow and Overflow Flags
- Precision Aperture Output
- Latch-Up Proof
- ESD: 2000 V Minimum

APPLICATIONS

- Battery Operated Instrumentation
- DAS
- Digital Camera
- Digital Oscilloscopes
- Spectrum Analysis
- Digital Radio

5

GENERAL DESCRIPTION

The XRD66L92 is a 12-bit 2-step high speed Analog-to-Digital Converter with DNL = ± 1 LSB and INL = ± 2.5 LSB. The XRD66L92 contains an internal track and hold which allows for analog input signals as fast as 5 MHz and can convert signals at a 1 MSPS rate.

The XRD66L92 operates with a single supply at +3.3 V. Separate pins for reference ladder terminals and power supplies allow flexibility for various A_{IN} , ΔV_{REF} and power supply ranges.

Data is presented at the serial output port every clock cycle with a 2.5 cycle pipeline delay. LINV and MINV enable binary and 2's complement data formatting. Through the 6 ladder tap pins, transfer function adjustment, and linearity can be accommodated.

ORDERING INFORMATION

Package Type	Temperature Range	Part No.	DNL (LSB)	INL (LSB)
SOIC	-40 to +85°C	XRD66L92AID	± 1	± 2.5
PDIP	-40 to +85°C	XRD66L92AIP	± 1	± 2.5

SIMPLIFIED BLOCK DIAGRAM

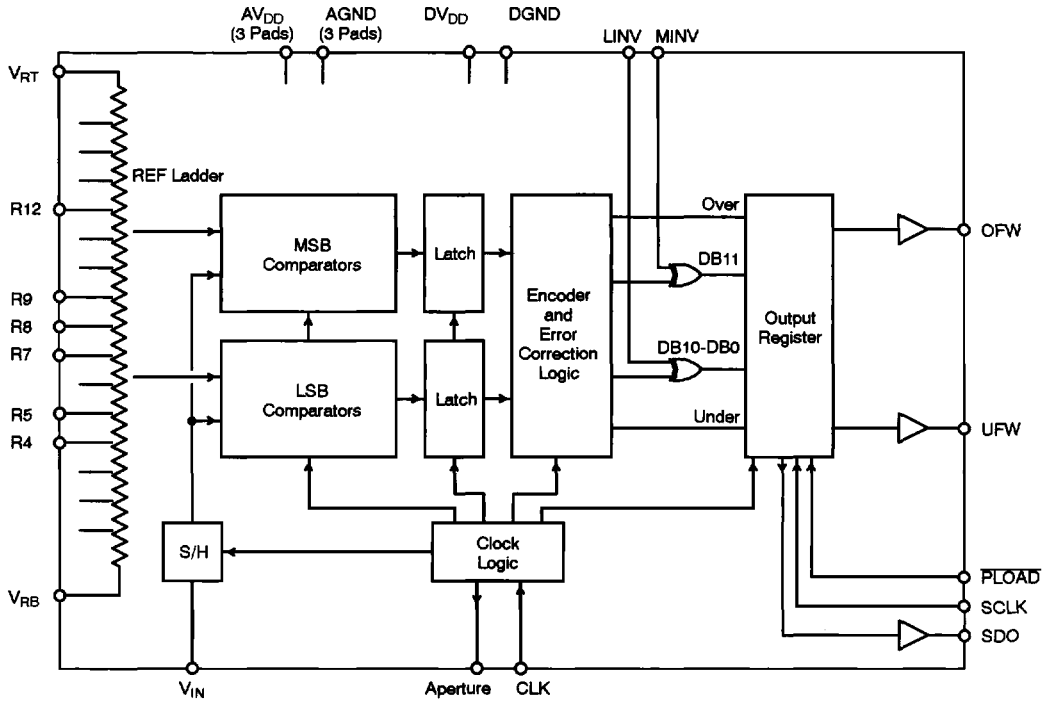

PIN CONFIGURATIONS

See Packaging Section for Package Dimensions

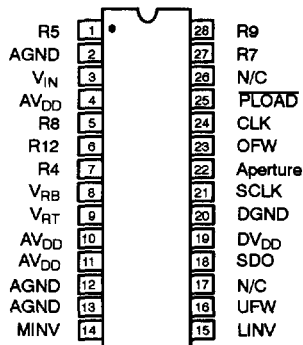

28 Pin PDIP (0.600")

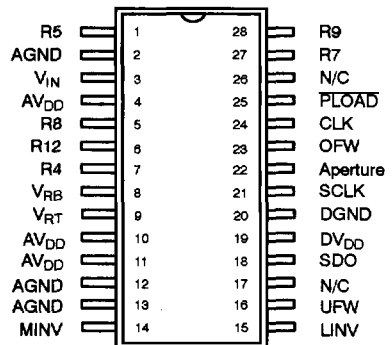

28 Pin SOIC (Jedec, 0.300")

PIN OUT DEFINITIONS

PIN NO.	NAME	DESCRIPTION
1	R5	Ref. Resistor Ladder Tap (5/16 V_{REF})
2	AGND	Analog Ground (Substrate)
3	V_{IN}	Analog Input
4	AV_{DD}	Analog Positive Supply
5	R8	Ref. Resistor Ladder Tap (1/2 V_{REF})
6	R12	Ref. Resistor Ladder Tap (3/4 V_{REF})
7	R4	Ref. Resistor Ladder Tap (1/4 V_{REF})
8	V_{RB}	Negative Reference
9	V_{RT}	Analog Positive Reference
10	AV_{DD}	Analog Positive Supply
11	AV_{DD}	Analog Positive Supply
12	AGND	Analog Ground (Substrate)
13	AGND	Analog Ground (Substrate)
14	MINV	Invert MSB (Active High)
15	LINV	Invert LSB (Active High)
16	UFW	Underflow Bit
17	N/C	No Connection
18	SDO	Serial Data Out
19	DV_{DD}	Digital Positive Supply
20	DGND	Digital Ground (Substrate)
21	SCLK	Serial Clock
22	Aperture	Aperture Delay Sync
23	OFW	Overflow Bit
24	CLK	Clock
25	\overline{PLOAD}	Serial Shift Register Data Load
26	N/C	No Connection
27	R7	Ref. Resistor Ladder Tap (7/16 V_{REF})
28	R9	Ref. Resistor Ladder Tap (9/16 V_{REF})

ELECTRICAL CHARACTERISTICS TABLE

Unless Otherwise Specified: $V_{DD} = 3.3\text{ V}$, $FS = 500\text{ kHz}$ (50% Duty Cycle),

$V_{RT} = 3.0\text{ V}$, $V_{RB} = \text{GND}$, $T_A = 25^\circ\text{C}$

Parameter	Symbol	Min	25°C Typ	Max	Units	Test Conditions/Comments
KEY FEATURES						
Resolution		12			Bits	
Max. Sampling Rate	FS	0.5	1.0		MHz	
ACCURACY¹						
Differential Non-Linearity	DNL			±1	LSB	Best Fit Line (Max INL - Min INL)/2
Integral Non-Linearity	INL			2.5	LSB	
Zero Scale Error	EZS		+10		LSB	
Full Scale Error	EFS		-10		LSB	
REFERENCE VOLTAGES³						
Positive Ref. Voltage ³	$V_{REF(+)}$	2.0		AV_{DD}	V	$V_{REF(+)} - V_{REF(-)}$
Negative Ref. Voltage ³	$V_{REF(-)}$	AGND			V	
Differential Ref. Voltage ³	V_{REF}	2.0		AV_{DD}	V	
Ladder Resistance	R_L		550		Ω	
ANALOG INPUT						
Input Bandwidth (-3 dB) ⁴	BW		5		MHz	Aperture pin load 5 pF Measured at 50% point
Input Voltage Range	V_{IN}	$V_{REF(-)}$		$V_{REF(+)}$	V p-p	
Input Capacitance Sample ⁵	C_{IN}		50		pF	
Input Capacitance Convert ⁵			8		pF	
Aperture Delay from Clock ²	t_{AP}		30		ns	
Aperture Delay from Aperture ² Signal	t_{AP}		0		ns	
DIGITAL INPUTS						
Logical "1" Voltage	V_{IH}	2.5			V	$V_{IN} = \text{GND to } V_{DD}$
Logical "0" Voltage	V_{IL}			0.5	V	
Leakage Currents ⁶ FLOAD, SCLK, CLK, MINV, LINV	I_{IN}		10		μA	
Input Capacitance			5		pF	
Clock Timing						
Clock Period ³	T_S	1000			ns	1/FS
Rise & Fall Time ⁷	t_R, t_F		15		ns	
"High" Time ³	t_{PWH}	500			ns	
"Low" Time ³	t_{PWL}	500			ns	
Duty Cycle ³			50		%	
Serial Register Timing						
Shift Clock Period	t_{SC}	110	80		ns	
Shift Clock to Data Delay	t_{SD}		30		ns	
Minimum Pulse Width FLOAD	t_S		50		ns	
Clock ↑ to FLOAD ↓ For Valid D11	t_{CP}		0		ns	
DIGITAL OUTPUTS						
Logical "1" Voltage	V_{OH}	$DV_{DD}-0.5$			V	$C_{OUT} = 15\text{ pF}$ $I_{LOAD} = 1\text{ mA}$ $I_{LOAD} = 1\text{ mA}$ $V_{OUT} = \text{GND to } V_{DD}$
Logical "0" Voltage	V_{OL}			0.5	V	
Tristate Leakage	I_{OZ}		1		μA	
Data Valid Delay ³	t_{DL}		100		ns	

ELECTRICAL CHARACTERISTICS TABLE (CONT'D)

Parameter	Symbol	Min	25°C Typ	Max	Units	Test Conditions/Comments
POWER SUPPLIES⁶ (Tmin to Tmax)						
Operating Voltage (AV _{DD} , DV _{DD})	V _{DD}	3	3.3	3.6	V	
Current (AV _{DD} + DV _{DD})	I _{DD}		8	12	mA	
AC PARAMETERS						
Signal Noise Ratio	SNR		66		dB	

NOTES

- Tester measures code transitions by dithering the voltage of the analog input (V_{IN}). The difference between the measured and the ideal code width (V_{REF}/4096) is the DNL error. The INL error is the maximum distance (in LSBs) from the best fit line to any transition voltage. Accuracy is a function of the sampling rate (FS).
- Guaranteed. Not tested.
- Specified values guarantee functionality. Refer to other parameters for accuracy.
- 3 dB bandwidth is a measure of performance of the A/D input stage (S/H amplifier). Refer to other parameters for accuracy within the specified bandwidth.
- Switched capacitor analog input requires driver with low output resistance.
- All inputs have diodes to V_{DD} and GND. Input(s) LINV and MINV have internal pull down(s). Input DC currents will not exceed specified limits for any input voltage between GND and V_{DD}.
- Condition to meet aperture delay specifications (t_{AR}, t_{AJ}). Actual rise/fall time can be less stringent with no loss of accuracy.
- All GND pins are connected through the silicon substrate.

Specifications are subject to change without notice

ABSOLUTE MAXIMUM RATINGS (TA = +25°C unless otherwise noted)^{1, 2, 3}

V _{DD} to GND	5.5 V	Storage Temperature	-65 to +150°C
V _{RT} & V _{RB}	V _{DD} +0.5 to GND -0.5 V	Lead Temperature (Soldering 10 seconds)	+300°C
V _{IN}	V _{DD} +0.5 to GND -0.5 V	Package Power Dissipation Rating @ 75°C	
All Inputs	V _{DD} +0.5 to GND -0.5 V	PDIP, SOIC	1050mW
All Outputs	V _{DD} +0.5 to GND -0.5 V	Derates above 75°C	14mW/°C

NOTES:

- Stresses above those listed under "Absolute Maximum Ratings" may cause permanent damage to the device. This is a stress rating only and functional operation at or above this specification is not implied. Exposure to maximum rating conditions for extended periods may affect device reliability.
- Any input pin which can see a value outside the absolute maximum ratings should be protected by Schottky diode clamps (HP5082-2835) from input pin to the supplies. All inputs have protection diodes which will protect the device from short transients outside the supplies of less than 100mA for less than 100µs.
- V_{DD} refers to AV_{DD} and DV_{DD}.

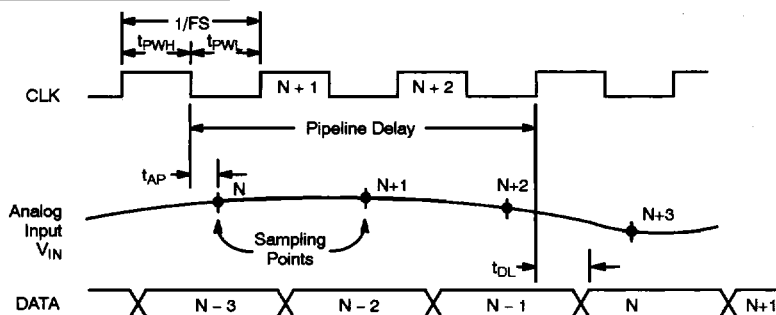

Figure 1. XRD66L92 Timing Diagram

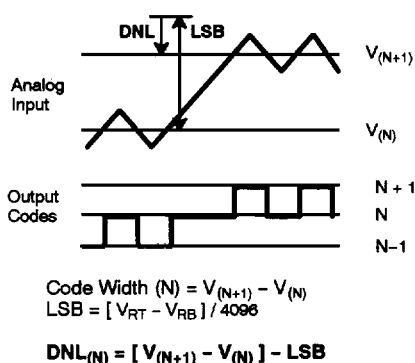

Figure 2. DNL Measurement

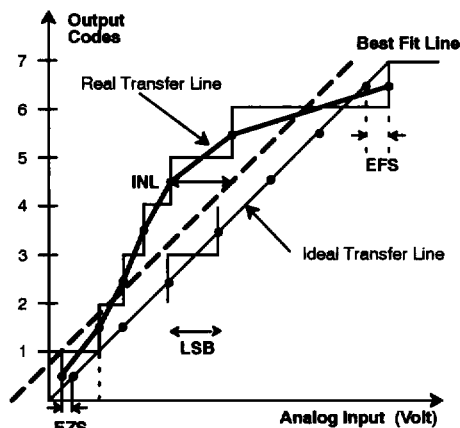

Figure 3. INL Error Calculation

UFW: Underflow (Output)

This signal indicates when the Analog Input (V_{IN}) goes below the V_{RB} range. It is normally at a low logic level. When $V_{IN} < V_{RB}$, OFW will go high and the data bits will show positive full scale (i.e. all 0's if MINV & LINV are low).

OFW: Overflow (Output)

This signal indicates when the Analog Input (V_{IN}) goes above the V_{RT} range. It is normally at a low logic level. When $V_{IN} > V_{RT}$, OFW will go high and the data bits will show positive full scale (i.e. all 1's if MINV & LINV are low).

SDO: Serial Data Output

After the internal shift register is updated using the \overline{PLOAD} signal, the SDO pin outputs the A/D result starting with the MSB

(which appears just after the \overline{PLOAD} strobe). Each bit is output on the rising edge of SCLK.

SCLK: Serial Data Port Clock

The SCLK controls the output of the serial port through SDO. SDO is updated on every rising edge of SCLK. The \overline{PLOAD} signal will override the SCLK signal.

\overline{PLOAD} :

Serial data port shift register load: When \overline{PLOAD} is low (i.e. level triggered not edge triggered), the current parallel data will be loaded into the shift register. \overline{PLOAD} overrides SCLK. When \overline{PLOAD} is high, the data can be shifted out through the SDO pin with SCLK.

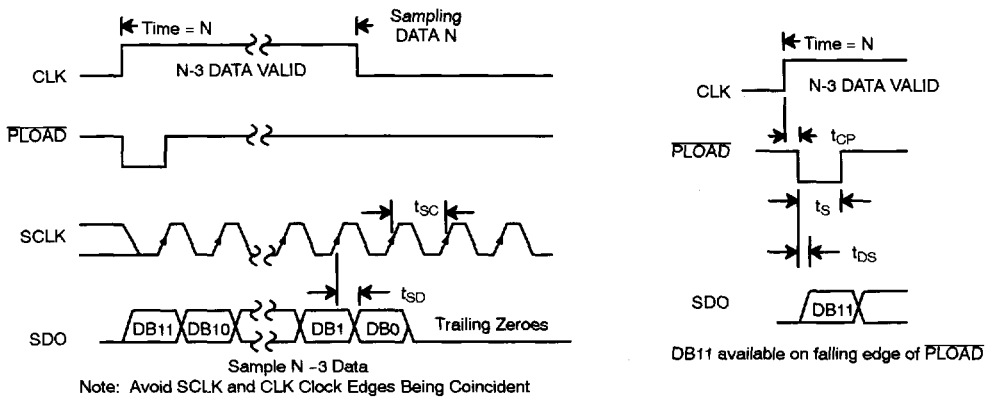

Figure 4. Serial Port Timing Chart
PHASE = 1

APERTURE: Aperture Delay Sync (output)

This signal is high when the internal sample/hold function is sampling V_{IN} , and goes low when it is in the hold mode (when the ADC is comparing the stored input value to the reference ladder).

The value of V_{IN} at the high to low transition of APERTURE is the value that will be digitized. A system can monitor this signal and adjust the CLK phase to accurately synchronize the sampling point to an external event.

5

MINV LINV	0 0	0 1	1 0	1 1
V_{RT}	111 ... 11 111 ... 10	100 ... 00 100 ... 01	011 ... 11 011 ... 10	000 ... 00 000 ... 01
V_{IN}	100 ... 01 100 ... 00	111 ... 10 111 ... 11	000 ... 01 000 ... 00	011 ... 10 011 ... 11
mid scale	011 ... 11	000 ... 00	111 ... 11	100 ... 00
V_{RB}	000 ... 01 000 ... 00	011 ... 10 011 ... 11	100 ... 01 100 ... 00	111 ... 10 111 ... 11
	binary	inverted 2's complement	2's complement	inverted binary

Table 2. Output Data Format Truth Table

MINV & LINV: Digital Output Format (inputs)

These signals control the format of the digital output data bits DB0 - DB11. Normally both pins are held low so the data is in straight binary format (all 0's when $V_{IN}=V_{RB}$; all 1's when $V_{IN}=V_{RT}$). If MINV is pulled high then the MSB (DB11) will be inverted. If LINV is pulled high then the LSBs (DB0 - DB10) will

be inverted. The OFW and UFW bits are not affected by these signals.

MINV & LINV are meant to be static digital signals. If they are to change during operation they should only change when the CLK is low. Changing MINV and/or LINV when CLK is high is acceptable, but the effects on the digital outputs will not be seen until the output latch of the output register is enabled. MINV and LINV

have internal pull down devices. Please see the simplified logic circuit (Figure 5.)

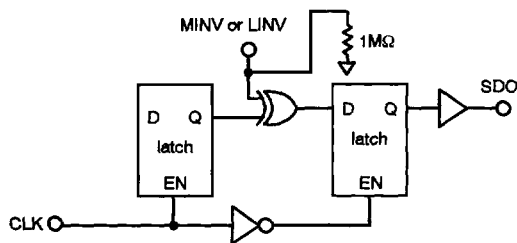

Figure 5. MINV, LINV Simplified Logic Circuit

V_{IN} Analog Input

The XRD66L92 has a switched capacitor track and hold input stage. V_{IN} is sampled at the high to low clock transition. Figure 6. shows the equivalent input circuit.

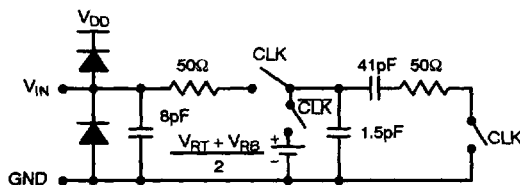

Figure 6. Equivalent Input Circuit

Reference Ladder Taps

These taps connect to every sixteenth point along the reference ladder; R4 is 4/16th up from V_{RB}, R7 is 7/16ths up from V_{RB}. These taps can also be used to alter the transfer curve of the ADC. The internal interconnect resistance from the pin to the ladder is less than 3Ω for the even numbered taps, (i.e. R4,R6, etc.) and is approximately 10Ω for the odd numbered taps.

Changing the transfer curve may be desirable to enhance or reduce the probability of codes for certain ranges of V_{IN}. This is often referred to as probability density function shaping, or histogram

shaping. 3mV maximum per tap is recommended for applications above 85°C.

APPLICATION NOTES

V_{IN} signals should not exceed V_{DD} +0.5V or go below GND -0.5V. All pins have internal protection diodes that will protect them from short transients (<100μs) outside the supply range.

All GND pins are connected internally through the P-substrate. DC voltage differences between these pins will cause undesirable internal substrate currents.

The power supply (V_{DD}) and reference voltage (V_{RT} & V_{RB}) pins should be decoupled with 0.1μF and 10μF capacitors to GND, placed as close to the chip as possible.

The digital outputs should not drive long wires or buses. The capacitive coupling and reflections will contribute noise to the conversion.

The reference tap pins can be used to create piecewise linear transfer functions. By forcing custom voltages on these pins, a 7-segment transfer function can be made. See Figure 7.

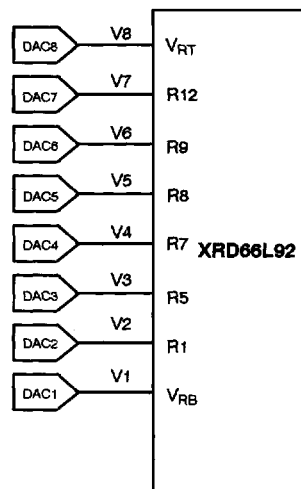

Only the Ladder detail shown.

Figure 7. A/D with Programmed Ladder Control for Creating a Piecewise Linear Transfer Function

PERFORMANCE CHARACTERISTICS

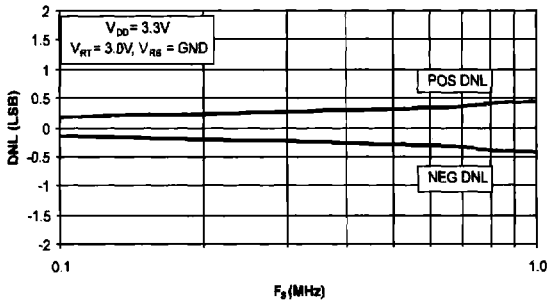

Graph 1. DNL vs. F_s

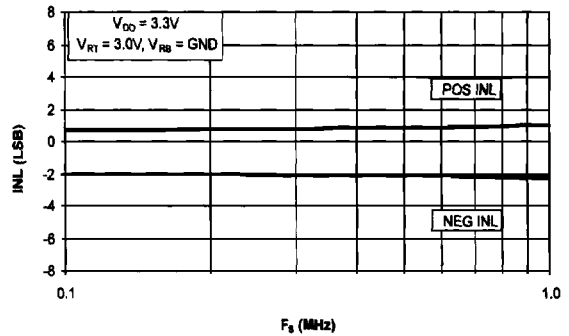

Graph 2. INL vs. F_s

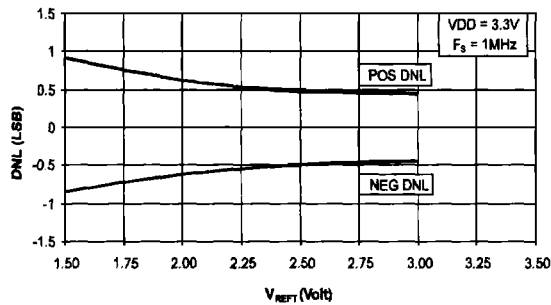

Graph 3. I_{DD} vs. F_s

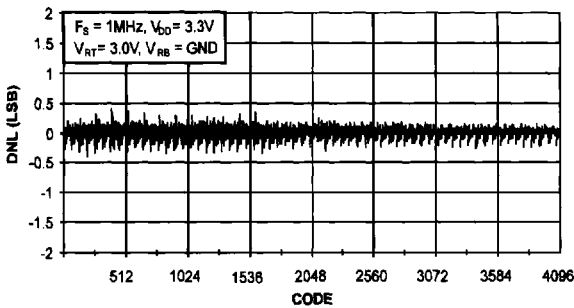

Graph 4. DNL Error Plot

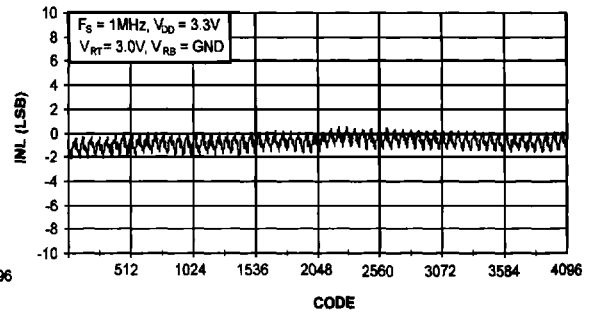

Graph 5. INL Error Plot

5