

# CPC5600A

## Optical Data Access Arrangement I.C.

### LITELINK™



#### DESCRIPTION

The CPC5600 is a single package optical Data Access Arrangement (DAA) in a low profile surface mount package. This device is well suited for modems, voice mail systems, fax machines, computer telephony applications, remote data access, medical, and security systems.

#### FEATURES

- Transformerless Optical Design
- Complete Ring Detector Circuit
- Electronic Inductor
- Caller ID Signal Detection
- Snoop Circuitry
- Integrated Hybrid
- Small 32-Pin Package
- PC Card Compatible
- PCB Space and Cost Savings
- FCC Compliant
- Compatible with U.S. and International Dial Up Phone Lines

#### APPLICATIONS

- Modems/Fax
- Computer Telephony
- Voice Mail Systems
- Security/Alarm Systems
- Utility Meters
- Vending Machines
- Voice Over IP
- Network Routers
- PBX Systems
- Home Medical Devices
- Plant Monitoring Equipment
- PC Mother Boards
- PBX Systems
- Set Top Boxes (Cable TV Modems)

#### RATINGS @ 25°C

Parameter	Min	Max	Units
Isolation Voltage	—	1500	V <sub>RMS</sub>
Tip/Ring Current (Continuous)	10	120	mA
Total Package Dissipation	—	1	W
Operational Temperature	-20	+85	°C
Storage Temperature	-40	+125	°C
Soldering Temperature (10 Seconds Max)	—	+220	°C

#### OPTIONS/SUFFIXES

- A: 32 Pin SOIC

#### APPROVALS

- UL1950/UL1459
- EN60950

#### Ordering Information

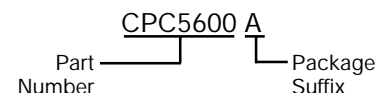

Unless Otherwise Noted all Specifications @ 25°C.

\* Refer to Typical Application Circuit.

PARAMETER	MIN	TYP	MAX	UNIT	CONDITION
<b>DC Characteristics</b>					
Operating Voltage $V_{CC}$	4.75	5	5.25	V	Modem Side
Operating Current $V_{CC}$	-	-	15	mA	Modem Side
Operating Voltage $V_{DD}$	3.5	-	5.25	V	From Tip and Ring
Operating Current $V_{DD}$	-	-	5	mA	Drawn from Tip and Ring
<b>On-Hook Characteristics</b>					
DC Resistance (metallic)	10	-	-	M $\Omega$	Tip to Ring, 100VDC Applied
DC Resistance (longitudinal)	10	-	-	M $\Omega$	150VDC Applied from Tip and Ring to Earth GND
Ring Signal Detection at 68 Hz*	5	-	-	V	Ring Signal Applied to Tip and Ring
Ring Signal Detection at 15 Hz*	28	-	-	V	Ring Signal Applied to Tip and Ring
Snoop Circuit Frequency Response*	600	-	4000	Hz	3dB Corner Frequency
Snoop Circuit CMRR	-	-40	-	dB	120V <sub>RMS</sub> 60Hz Common Mode Signal on Tip/Ring
Ringer Equivalence	-	0.1B	-	REN	-
Longitudinal Balance	60	-	-	dB	Per FCC Part 68.3
<b>Off-Hook Characteristics</b>					
AC Impedance*	-	600	-	$\Omega$	Tip to Ring
Longitudinal Balance	40	-	-	dB	Tip and Ring to Ground, per FCC part 68.3
Return Loss	-	26	-	dB	Against 600 $\Omega$ , 1800Hz
<b>Transmit/Receive Characteristics</b>					
Frequency Response*	30	-	4000	Hz	3dB corner frequency
Trans-Hybrid Loss*	-	30	-	dB	Against 600 $\Omega$ resistive, 1800Hz
Transmit Insertion Loss*	-1	0	1	dB	-
Receive Insertion Loss*	-1	0	1	dB	-
Average In-band Noise	-	-90	-	dB	4kHz Flat bandwidth
Harmonic Distortion	-	-	-80	dB	-3dBm, 600Hz, 2nd Harmonic
Transmit Level*	-	-	0	dBm	Single Tone Sine Wave
Receive Level*	-	-	0	dBm	Single Tone Sine Wave
Rx+/Rx- Output Drive Current	-	-	0.5	mA	Sink and Source
Tx+/Tx- Input Impedance	60	90	120	k $\Omega$	-
<b>Isolation Characteristics</b>					
Isolation Surge Voltage	1500	-	-	V <sub>SURGE</sub>	Line Side to Modem Side
Surge Rise Time	2000	-	-	V/ $\mu$ s	No Damage via T/R
<b>Control Logic (OH, CID, RING)</b>					
Input Threshold Voltage	0.8	-	2.0	V	
High Level Input Current	-	-	-20	$\mu$ A	
Low Level Input Current	-100	-	-	$\mu$ A	
Output High Voltage	$V_{CC}-0.4$	-	-	V	1M $\Omega$ to Ground
Output Low Voltage	-	-	0.4	V	1M $\Omega$ to $V_{CC}$

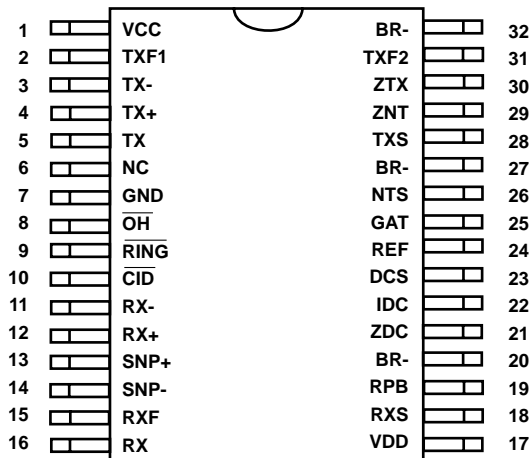
**PACKAGE PINOUT**

Pin #	Name	Function
1	V <sub>CC</sub>	Host power supply, +5 Volts +/-5%.
2	TXF1	TX isolation amplifier output.
3	TX -	NEG differential transmit signal into DAA.
4	TX+	POS differential transmit signal into DAA.
5	TX	TX differential amplifier input.
6	NC	Not Connected.
7	GND	Connect to host analog ground.
8	OH	Driving this signal low asserts the off-hook condition.
9	RING	Active low indicates an incoming half waved ring signal pulsed High to Low at the ring frequency-typically 20Hz.
10	CID	Driving this signal low places the Caller ID information on the RX pins when the DAA is on hook (OH is de-asserted).
11	RX-	NEG differential analog receive signal from the telephone line and must be AC coupled with a 0.1 uF capacitor.
12	RX+	POS differential analog receive signal from the telephone line and must be AC coupled with a 0.1 uF capacitor.
13	SNP+	One of two differential snoop inputs.
14	SNP-	One of two differential snoop inputs.
15	RXF	Receive photodiode amplifier output.
16	RX	Receive photoamplifier summing junction.
17	V <sub>DD</sub>	Power supply for line side portion of CPC5600A.
18	RXS	Receive photodiode servo input.
19	RPB	Sets receive LED prebias current.
20	BR-	Return to bridge rectifier negative output.
21	ZDC	Sets electronic inductor DCR/Current Limit.
22	IDC	Main loop current path from Tip to Ring.
23	DCS	VI slope control via external resistor.
24	REF	1.25V internal voltage reference.
25	GAT	Depletion MOSFET gate control.
26	NTS	Receive signal input path via Tip and Ring.
27	BR-	Return to bridge rectifier negative output.
28	TXS	Receive photodiode amplifier input.
29	ZNT	Sets DAA impedance via external passive network.
30	ZTX	Transmit Transconductance gain setting pin.
31	TXF2	Receive photodiode amplifier output.
32	BR-	Return to bridge rectifier negative output.

**BLOCK DIAGRAM**

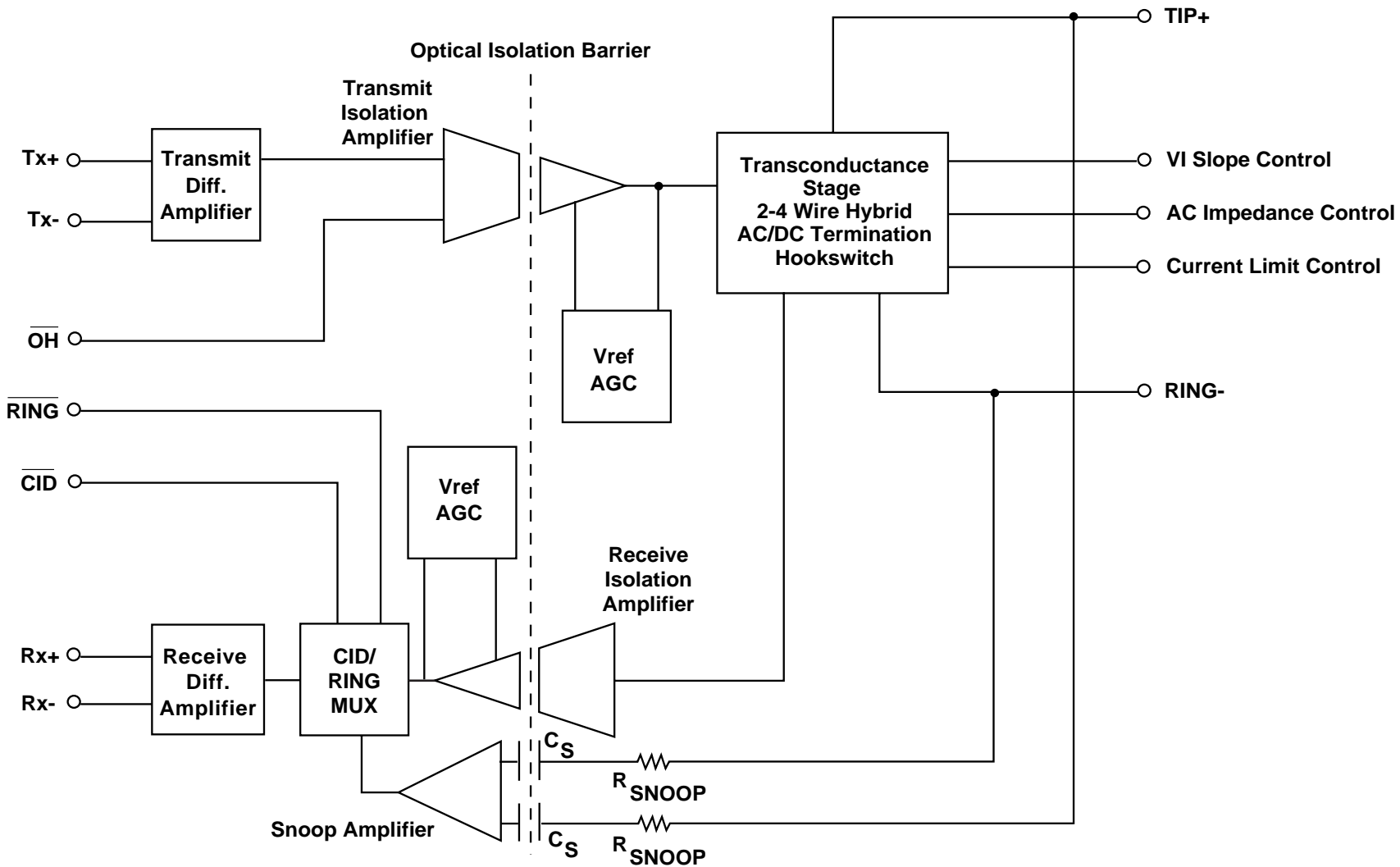

## Functional Description

### Introduction

The LITELINK™ (CPC5600) is a single package International Data Access Arrangement solution that is designed to be used in a variety of telephone applications. The LITELINK™ uses advanced optical signal coupling techniques to provide the required electrical isolation between the telephone and the Customer Premises Equipment (CPE). The LITELINK™ differs from other solutions using optical or capacitive isolation techniques by including the barrier inside the IC package thus eliminating the need for external optocouplers or high-voltage capacitors resulting in overall reduced board space.

### Ring Detection via Snoop Circuit

While in the on-hook state ( $\overline{\text{OH}}$  deasserted), an internal multiplexer turns on a “snoop” circuit that actively monitors the phone line for two conditions: incoming ring signal and Caller ID (CID) information. The snoop circuit “snoops” the line continuously while drawing a low 2uA max. current from the telephone line thus meeting regulatory requirements. When the central office (CO) places a ring signal on the telephone line,  $90V_{\text{RMS}}$  max, the RING output is pulsed from High to Low for 2 seconds at the same frequency as the AC signal, typically 20Hz, and restored to High during the 4 second delay. The ring detection circuitry is designed to reject false signaling from pulse dialing circuits or noise on the line.

### Caller ID (CID) Detection via Snoop Circuit

CID is a service provided by the telephone company to provide caller information (i.e. the caller's telephone number) to the called party. The  $\overline{\text{CID}}$  signal is present on the telephone line after the first ring burst is sent from the CO. After this first ring burst is detected by the host, the host asserts the  $\overline{\text{CID}}$  line which automatically couples the snoop circuit to the RX outputs on the LITELINK™. After the  $\overline{\text{CID}}$  signal is processed by the host, the host will deactivate the  $\overline{\text{CID}}$  signal. At this point the host can answer the call by asserting the  $\overline{\text{OH}}$  signal. Note that when the LITELINK™ goes off-hook it automatically disconnects the snoop path from both RX and RING outputs. Signals appearing on the telephone line are now coupled through the optical isolation barrier in the LITELINK™ and not via the snoop path.

### Hook Switch Control

The  $\overline{\text{OH}}$  or off-hook input is used to place the DAA on or off-hook. When the input is High, the DAA is on-hook or ready to receive calls from the CO. In this mode the snoop circuitry is enabled as described above. Driving  $\overline{\text{OH}}$  Low places the DAA off-hook allowing the CO supplied loop current to flow (120mA max.), indicating the DAA is answering or preparing to place a call.

### Transmit Signal

Outgoing analog signals to be transmitted to the telephone lines are placed differentially on the TX+ and TX- inputs of the CPC5600. Transmit level from the user device is limited to 0dBm or 2.1Vp-p. The differential transmit signal is converted to a single ended signal by the CPC5600. The transmit signal is transferred across an optical barrier by an electrical-optical-electrical amplifier, which is transparent to the user. Variations in gain due to electrical-optical-electrical efficiency are virtually eliminated by an on-chip automatic gain control circuit which sets the input to output gain of the photodiode amplifier to 1. This results in a TX insertion loss of +/- 1dB.

### Receive Signal

Incoming analog signals from the telephone lines appearing between Tip and Ring are optically received and coupled to the RX+ and RX- outputs of the CPC5600. This is done in the same manner as transmitting the signal (electrical-optical-electrical) described above. The AGC circuit is also used by the receive circuit resulting in a RX insertion loss of 0 +/- 1dB or -6 +/- 1dB as selected by the user. Distortion at the RX outputs is rated at -80dB max. at a receive level of -3dB @ 300Hz. Since the RX outputs are biased at 2.5VDC, it is necessary to use 0.1uF blocking capacitors for coupling the receive signal to the host.

TYPICAL U.S. APPLICATION

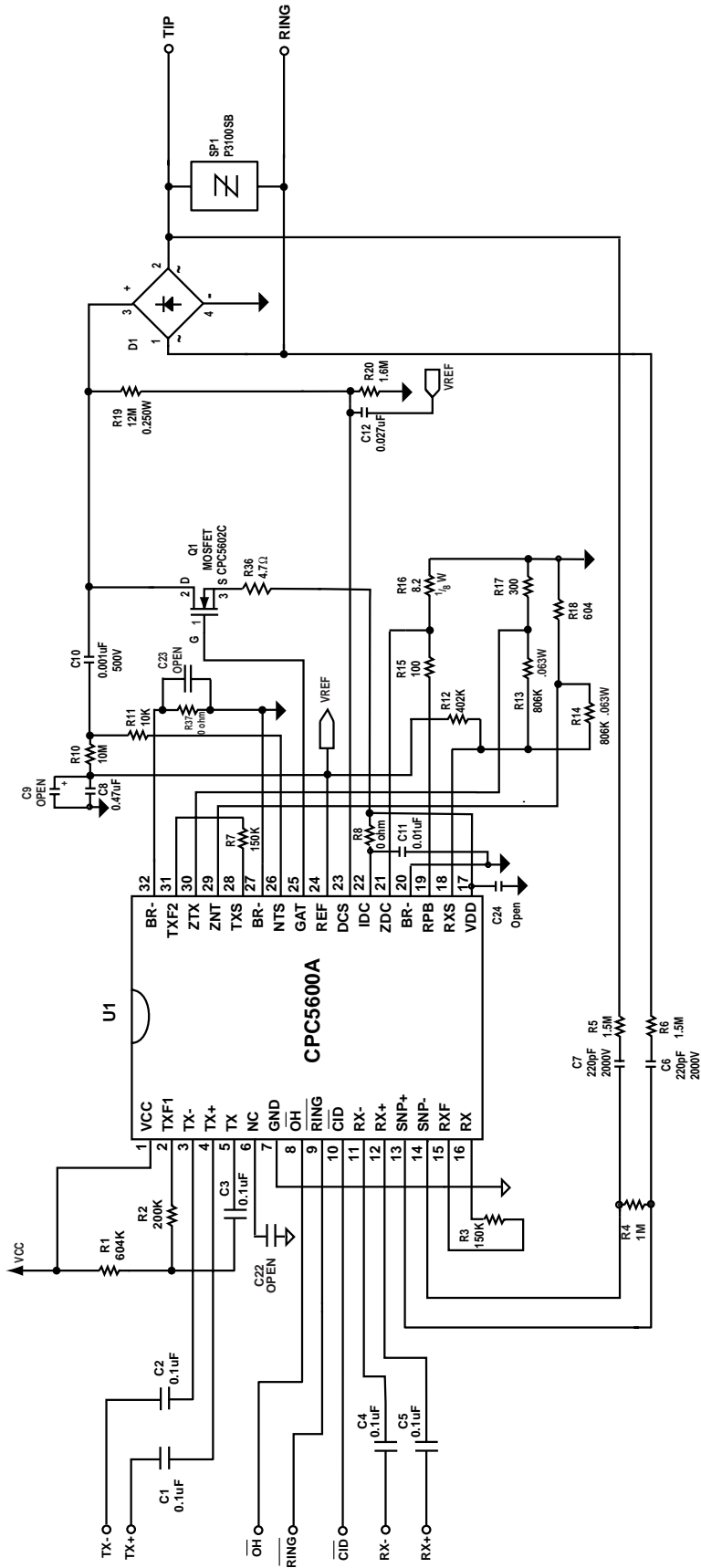

Drawn: JC/MG	Date: 10/28/99	Rev: G-3
Company: CP Clare Corp.		
Title: U.S. Reference Design		

ALL RESISTORS ARE .100W UNLESS OTHERWISE NOTED

**MECHANICAL DIMENSIONS**

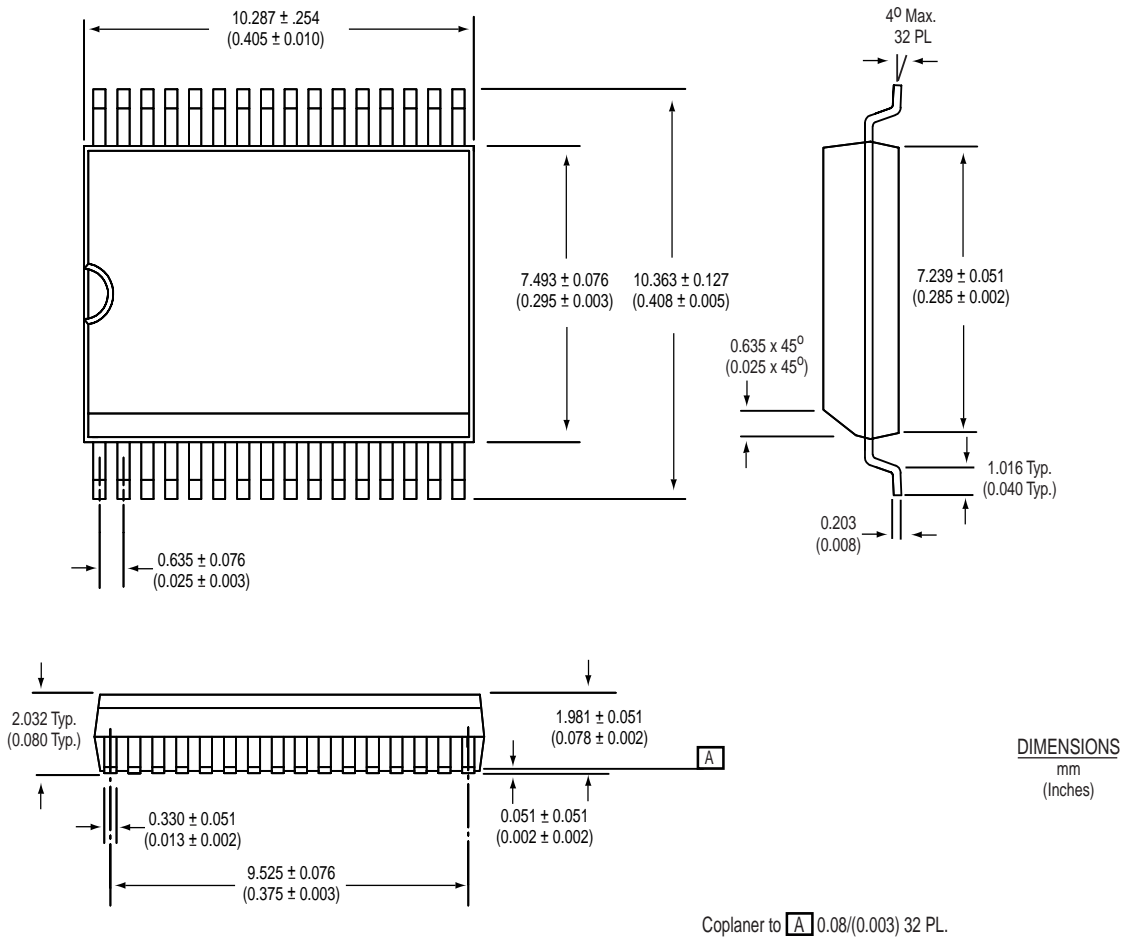

**Recommended Pad Layout**

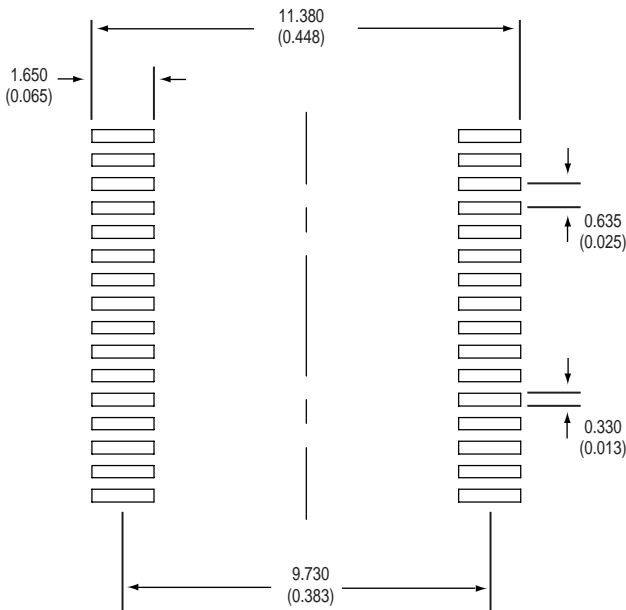

**NORTH AMERICA****North American Sales Office**

Clare  
78 Cherry Hill Drive  
Beverly, MA 01915  
Tel: 1-978-524-6700  
Fax: 1-978-524-4900  
Toll Free: 1-800-272-5273

**Eastern Regional Sales**

Clare  
78 Cherry Hill Drive  
Beverly, MA 01915  
Tel: 1-978-524-6700  
Fax: 1-978-524-4900  
Toll Free: 1-800-272-5273

**Mid-American Regional Sales**

Clare  
78 Cherry Hill Drive  
Beverly, MA 01915  
Tel: 1-978-524-6700  
Fax: 1-978-524-4900  
Toll Free: 1-800-272-5273

**Northwestern Regional Sales**

Clare  
2010 Crow Canyon Place  
Suite 100  
San Ramon, CA 94583  
Tel: 1-925-277-3422  
Fax: 1-925-277-3423  
Toll Free: 1-800-272-5273

**Southwestern Regional Sales**

Clare  
2816 Nevis Circle  
Costa Mesa, CA 92626  
Tel: 1-714-556-3661  
Fax: 1-714-546-4254  
Toll Free: 1-800-272-5273

**Canadian Regional Sales**

Clare Canada Ltd.  
3425 Harvester Road  
Suite 202  
Burlington, Ontario L7N 3N1  
Tel: 1-905-333-9066  
Fax: 1-905-333-1824

**EUROPE****European Sales Office**

CP Clare nv  
Bampslaan 17  
B-3500 Hasselt (Belgium)  
Tel: 32-11-300868  
Fax: 32-11-300890

**France**

CP Clare France  
31 Cours des Juilliottes  
94700 Maisons Alfort  
France  
Tel: 33 (1) 56-29-14-14  
Fax: 33 (1) 56-29-14-15

**Germany**

CP Clare Elektronik GmbH  
Leonberger Strasse 20  
D-71638, Ludwigsburg  
Tel: 49-7141-9543-0  
Fax: 49-7141-9543-20

**Italy**

C.L.A.R.E.s.a.s.  
Via C. Colombo 10/A  
I-20066 Melzo (Milano)  
Tel: 39-02-95737160  
Fax: 39-02-95738829

**Sweden**

Clare Sales  
Comptronic AB  
Box 167  
S-16329 Spånga  
Tel: 46-862-10370  
Fax: 46-862-10371

**United Kingdom**

Clare UK Sales  
Marco Polo House  
Cook Way  
Bindon Road  
Taunton  
UK-Somerset TA2 6BG  
Tel: 44-1-823 352541  
Fax: 44-1-823 352797

**ASIA PACIFIC****Asian Sales Office**

Clare  
Room N1016, Chia-Hsin, Bldg II,  
10F, No. 96, Sec. 2  
Chung Shan North Road  
Taipei, Taiwan R.O.C.  
Tel: 886-2-2523-6368  
Fax: 886-2-2523-6369

**JAPAN****Japanese Sales Office**

Clare  
Tosei Building 5F  
2-23-1, Ikebukuro, Toshima-ku  
Tokyo 171  
Tel: 03-3980-2212  
Fax: 03-3980-2213

**HEADQUARTERS**

Clare  
78 Cherry Hill Drive  
Beverly, MA 01915  
Tel: 1-978-524-6700  
Fax: 1-978-524-4900  
Toll Free: 1-800-272-5273

<http://www.clare.com>

---

*Clare makes no assertion or warranty that the circuitry and the uses thereof disclosed herein are non-infringing on any valid US or foreign patents. CP Clare assumes no liability as a result of the use of said specifications and reserves the right to make changes to specifications without notice. CP Clare does not authorize or warrant any CP Clare device for use in life support devices and/or systems. Contact your nearest CP Clare Sales Office for the latest specifications.*

---

Protected by U.S. Patent #5,946,394

Specifications: DS-CPC5600A-R1  
©Copyright 1999, Clare  
All rights reserved. Printed in USA.  
10/29/99