

# Multichannel Erbium-doped Fiber Amplifier (EDFA)

## WRA-217



### Key Features



- Protocol and data-rate independent, including 10 Gbps/OC-192 applications
- Easily configurable as a booster or as pre/inline C-band amplifier
- Constant signal gain mode configurable from 13 dB up to 23 dB
- Constant output power mode configurable from -6 dBm up to +17 dBm
- Optical output monitor port
- Low power consumption and noise figure
- Ultrafast transient response: 75  $\mu$ s typical

### Applications

- DWDM booster or pre/inline amplifier
- Access and metro optical networks
- DWDM point-to-point applications
- DWDM optical add-drop or X-C nodes
- Agile Optical Networks

### Compliance

- Telcordia NEBS Level 3
- FDA Class 1M laser device
- FCC Class A device
- UL 60950-1 First Edition
- CAN/CSA C22.2 No. 60950 01
- CE
- IEC 60825-2
- RoHS 5/6

The WaveReady™ WRA-217 is dense wavelength division multiplexing (DWDM) optical amplifier that is totally user configurable. This multichannel amplifier provides a simple and economical C-band optical amplification solution in a flexible, ready-to-use package. The WRA-217 amplifier includes an advanced gain control circuit, an efficient pump laser and a midstage variable attenuator.

The WRA-217 can be configured as a booster or as a pre/inline amplifier. The module works by default in constant signal gain mode, but can be configured to constant total output power mode. Its ease-of-use and performance make the WRA-217 the ideal solution for access and metro DWDM optical networks.

Front panel light emitting diodes (LEDs) indicate module status, while integrated electronics provide alarm and control functionality.

Deployed with a WaveReady™ communications module (COM200), these units can be managed and configured remotely through TL1, SNMP, or by using the WaveReady™ Node Manager. Local and remote management are done through an RS-232 or Ethernet port on the communications module.

The module is installed in a WaveReady 3500F or 3100 shelf mounted in 19- or 23-inch telecommunications racks.

### AON and Agile Optical Amplifiers

The WRA-217 is part of JDSU's agile optical amplifiers family, products designed for agile optical networks (AONs). Agile optical amplifiers use advanced transient suppression techniques to dynamically respond to changes in the number of wavelengths or signal powers. As a result, they preserve gain flatness and output power over a wide range of input conditions to meet the needs of reconfigurable optical networks.

2

Amplification for Extended-reach and Pre-amp Application

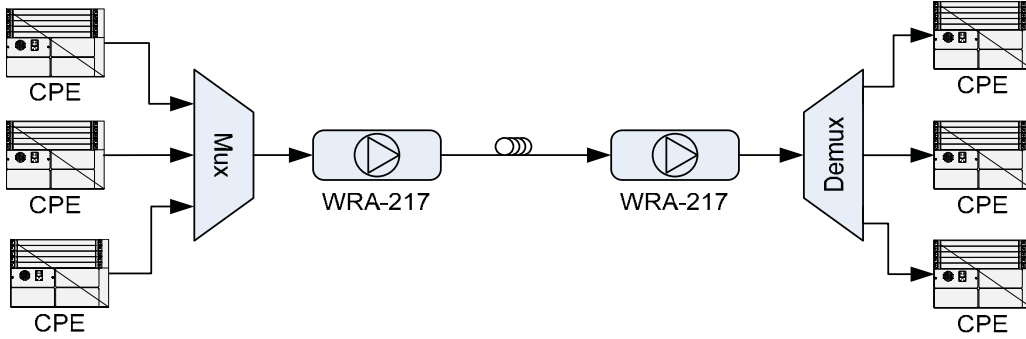

Typical Link Budget

Number of wavelengths	Power	Total power budget	Maximum distance
1	+17 dBm	46 dB	184 km
16	+17 dBm	34 dB	136 km

Figure 1: Power mask with noise figures<sup>1</sup> for WRA-217

WRA-217 Power Mask

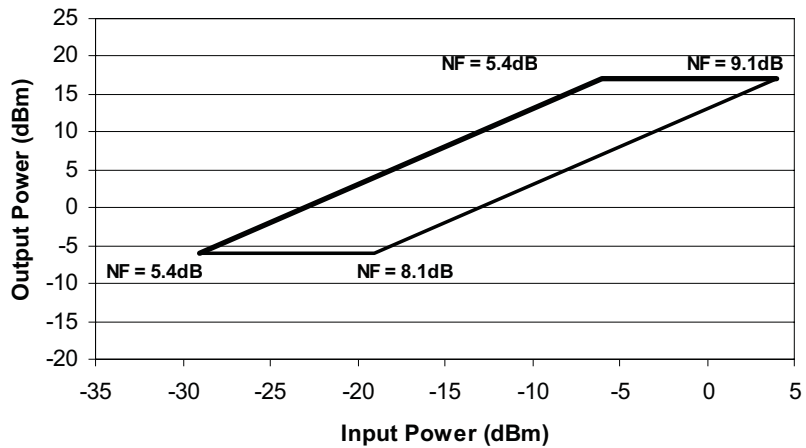

1. Noise figures are maximum, EOL values.

### 3

#### Optical Performance<sup>1</sup>

Parameter	Minimum	Typical	Maximum
Operating wavelength range	1530 nm	-	1563 nm
Input power range	-29 dBm	-	+4 dBm
Total output power (User configurable in constant Pout mode; 0.1 dB set resolution)	-6 dBm	-	+17 dBm
Input LOS threshold configurable range (User configurable; 1.0 dB set resolution)	-38 dBm	-	0 dBm
Transient response	-	75 μs	-
Power measurement accuracy (all detectors)			
P ≥ -29 dBm	-0.7 dB	-	+0.7 dB
-29 < P ≤ -38 dBm	-1.5 dB	-	+1.5 dB
Gain (User settable in constant gain mode. 0.1 dB set resolution)	13 dB	-	23 dB
Polarization dependent gain	-	-	0.5 dB
Gain flatness over all operating wavelengths			
15 to 45°C ambient to shelf	-	-	±0.75 dB
-5 to 55°C ambient to shelf	-	-	±1 dB
Gain accuracy (Relative to gain target, in constant gain mode)	-1.0 dB	-	+1.0 dB
Gain stability (Peak-to-peak, in constant gain mode)	-0.1 dB	-	0.1 dB
Noise figures		See Figure 1	
Monitor tap ratio	-21.5 dB	-	-18.5 dB
Polarization mode dispersion	-	-	0.5 ps
Backward ASE at input	-	-	-30 dBm
Remnant 980 to output	-	-	-20 dBm
Return loss	-40 dB	-	-

1. Unless otherwise stated, all specifications are end-of-life, over all temperature and input conditions.

#### Electrical Specifications<sup>1</sup>

Parameter	Minimum	Typical	Maximum
DC supply voltage	-	-48 V	-
Power dissipation	-	12 W	17 W
Alarm relay signals	Dry contact major and minor alarms. Relay open under normal operation. Relay closed when power is off.		

1. Electrical specifications assume installation in a WaveReady 3500F or 3100 shelf (DMS-3500FSE03 or DMS-3100DC004).

#### Physical Specifications

Parameter	Typical
Size (H x W x D)	6.8 x 1.0 x 8.8 inches (17.27 x 2.54 x 22.35 cm)
Weight (approximate)	1.6 lbs (0.73 kg)

# 4

## Environmental Specifications

Parameter	Minimum	Typical	Maximum
Normal operating temperature	0°C	-	40°C
Extended operating temperature	-5°C	-	55°C
Storage temperature	-40°C	-	85°C
Relative humidity (non-condensing)	5%	-	90%

## Interface Specifications

Parameter	Specification
Optical	LC/UPC SMF
Craft	Requires WaveReady 3100 or 3500F series shelf and a WaveReady COM200 communications module. Craft access through RS-232/DB9 connector on front panel of COM200 module.
TL1/SNMP	Requires WaveReady 3500F or 3100 series shelf and a WaveReady COM200 communications module. TL1/SNMP interfaces via the 10/100Base-T Ethernet/RJ45 connector on the front panel of a COM200.
Front panel	Six LEDs: <b>CARD</b> (power); <b>MAJ/CRIT</b> (major/critical alarm); <b>MIN</b> (minor alarm); <b>TX</b> and <b>RX</b> (port status), <b>Laser On</b>

## Ordering Information

For more information on this or other products and their availability, please contact your local JDSU account manager or JDSU directly at 1-800-498-JDSU (5378) in North America and +800-5378-JDSU worldwide or via e-mail at [customer.service@jdsu.com](mailto:customer.service@jdsu.com).

### Sample: WRA-217

Product Code	Description
WRA-217C0001B	Multichannel EDFA

### Associated Parts

Product Code	Description
DMS-3100DC004	WR3100 1U Shelf
DMS-3500FSE03	WR3500F Shelf
COM-200ET003Y	COM200 Communication module