

# LH57127/J ✓

## CMOS 128K (16K × 8) OTPROM/EPROM

### FEATURES

- 16,384 × 8 bit organization
- Access times:
  - LH57127J: 100 ns (MAX.)
  - LH57127: 120 ns (MAX.)
- Single +5 V power supply
- Low power consumption:
  - Operating: 315 mW (MAX.)
  - Standby: 1.05 mW (MAX.)
- Fully static operation
- Three-state outputs
- TTL compatible I/O
- High speed programming:
  - Compatible to INTEL intelligent programming™ algorithm (64 second programming)
- Pin compatible with i27128
- Packages:
  - EPROM
    - 28-pin, 600-mil CERDIP
  - OTPROM
    - 28-pin, 600-mil DIP
- JEDEC standard pinout

### DESCRIPTION

The LH57127J is a CMOS UV erasable and electrically programmable read-only-memory, organized as 16,384 × 8 bits. It is pin compatible with the Intel i27128 and the SHARP LH57128J, and designed to have fast access time.

The LH57127 is a one-time PROM packaged in plastic DIP.

### PIN CONNECTIONS

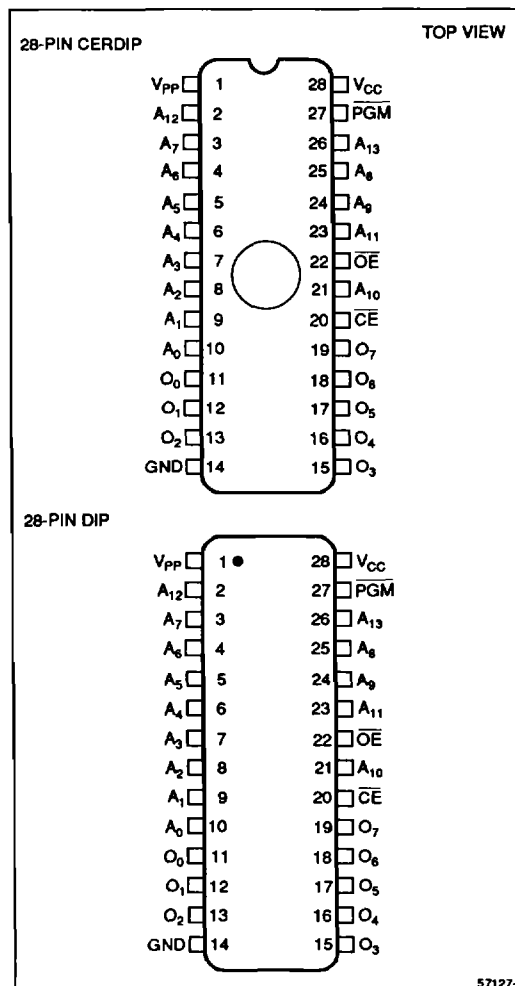

Figure 1. Pin Connections for CERDIP and DIP Packages

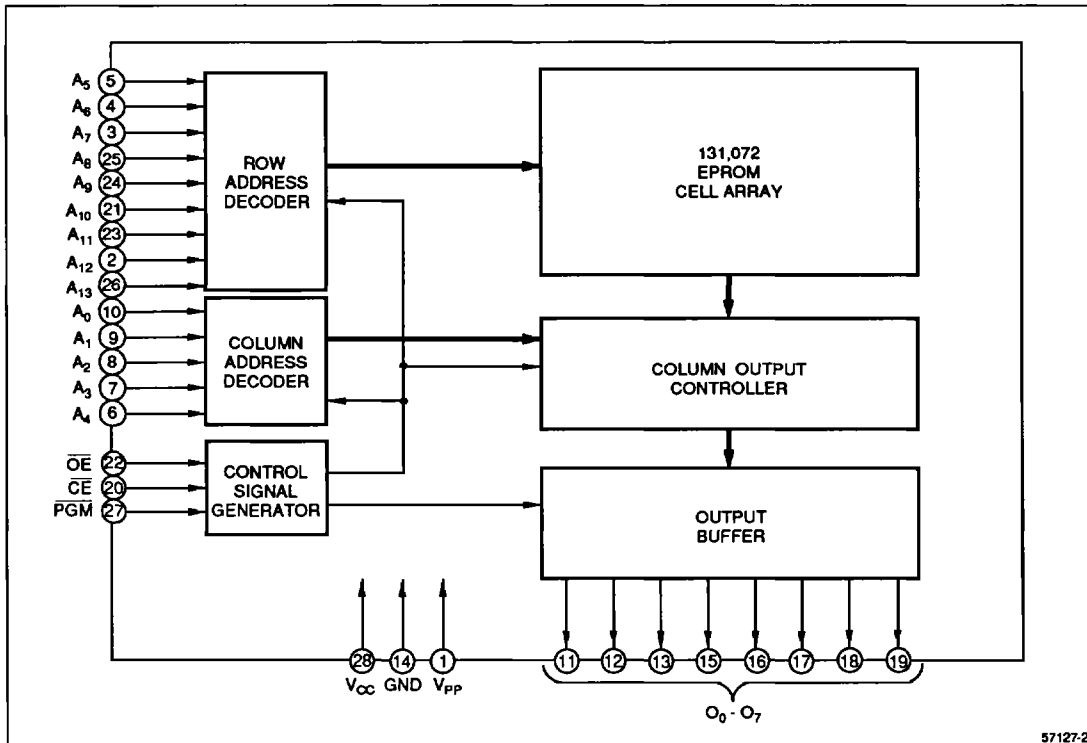

Figure 2. LH57127/J Block Diagram

**PIN DESCRIPTION**

SIGNAL	PIN NAME	NOTE
A <sub>0</sub> -A <sub>13</sub>	Address input	
O <sub>0</sub> -O <sub>7</sub>	Data output (input)	1
$\overline{CE}$	Chip Enable input	
$\overline{OE}$	Output Enable input	

SIGNAL	PIN NAME	NOTE
PGM	Program input	
V <sub>PP</sub>	Program power	
V <sub>CC</sub>	Power supply	
GND	Ground	

**NOTE:**

1. O<sub>0</sub> - O<sub>7</sub> pins are also used to input data to the column output controller through input buffers in programming mode.

**TRUTH TABLE**

MODE		O <sub>0</sub> - O <sub>7</sub>	$\overline{CE}$	$\overline{OE}$	PGM	V <sub>CC</sub>	V <sub>PP</sub>
Read	Read	Data out	L	L	H	+5 V	+5 V
	Output disable	High-Z	L	H	H	+5 V	+5 V
	Standby	High-Z	H	X	X	+5 V	+5 V
Program	Program	Data in	L	H	L	+6 V	+12.5 V
	Program verify	Data out	L	L	H	+6 V	+12.5 V
	Program inhibit	High-Z	H	X	X	+6 V	+12.5 V

**NOTE:**

X = H or L, H = V<sub>IH</sub>, L = V<sub>IL</sub>

## ABSOLUTE MAXIMUM RATINGS

PARAMETER	SYMBOL	RATING	UNIT	NOTE
Supply voltage	V <sub>CC</sub>	-0.6 to +7.0	V	1
	V <sub>PP</sub>	-0.6 to +13.5		
	V <sub>IN</sub> , V <sub>OUT</sub>	-0.6 to +7.0		
Operating temperature	T <sub>opr</sub>	0 to +70	°C	
Storage temperature	T <sub>stg</sub>	-65 to +150	°C	2
		-55 to +150		3

## NOTES:

- The maximum applicable voltage on any pin with respect to GND.  
Maximum ratings are those values beyond which damage to the device may occur.
- Applied to ceramic package.
- Applied to plastic package.

RECOMMENDED OPERATING CONDITIONS (Read Mode) (T<sub>A</sub> = 0 to +70°C)

PARAMETER	SYMBOL	MIN.	TYP.	MAX.	UNIT
Supply Voltage	V <sub>CC</sub>	4.75	5.0	5.25	V
	V <sub>PP</sub>	4.75	5.0	5.25	V
Input "Low" voltage	V <sub>IL</sub>	-0.1		0.8	V
Input "High" voltage	V <sub>IH</sub>	2.0		V <sub>CC</sub> + 0.3	V

DC CHARACTERISTICS (Read Mode) (V<sub>CC</sub> = 5 V ± 5%, V<sub>PP</sub> = V<sub>CC</sub>, T<sub>A</sub> = 0 to +70°C)

PARAMETER	SYMBOL	CONDITIONS	MIN.	TYP.	MAX.	UNIT	NOTE
Input "Low" voltage	V <sub>IL</sub>		-0.1		0.8	V	
Input "High" voltage	V <sub>IH</sub>		2.0		V <sub>CC</sub> + 0.3	V	
Output "Low" voltage	V <sub>OL</sub>	I <sub>OL</sub> = 2.1 mA			0.45	V	
Output "High" voltage	V <sub>OH</sub>	I <sub>OH</sub> = -400 μA	2.4			V	
Input leakage current	I <sub>LI</sub>	V <sub>IN</sub> = GND or V <sub>CC</sub>	-10		10	μA	
Output leakage current	I <sub>LO</sub>	V <sub>OUT</sub> = GND or V <sub>CC</sub>	-10		10	μA	
V <sub>CC</sub> operating current	I <sub>CC1</sub>	$\overline{CE} = GND \pm 0.3 V$			60	mA	1, 2
	I <sub>CC2</sub>	$\overline{CE} = V_{IL}$			60	mA	1, 3
V <sub>PP</sub> supply current	I <sub>PP</sub>	V <sub>PP</sub> = V <sub>CC</sub>			100	μA	
V <sub>PP</sub> pin voltage	V <sub>PP</sub>		V <sub>CC</sub> - 0.4		V <sub>CC</sub>	V	
V <sub>CC</sub> Standby current	I <sub>SB1</sub>	$\overline{CE} = V_{CC} \pm 0.3 V$			200	μA	
	I <sub>SB2</sub>	$\overline{CE} = V_{IH}$			10	mA	

## NOTES:

- Minimum cycle time, I<sub>OUT</sub> = 0 mA
- CMOS level: V<sub>IN</sub> = GND ± 0.3 V or V<sub>CC</sub> ± 0.3 V
- TTL input: V<sub>IN</sub> = V<sub>IL</sub> or V<sub>IH</sub>

AC CHARACTERISTICS (Read Mode) (V<sub>CC</sub> = 5 V ± 5%, V<sub>PP</sub> = V<sub>CC</sub>, T<sub>A</sub> = 0 to +70°C)

PARAMETER	SYMBOL	LH57127J-10		LH57127-12		UNIT
		MIN.	MAX.	MIN.	MAX.	
Address to output delay	t <sub>ACC</sub>		100		120	ns
$\overline{CE}$ to output delay	t <sub>CE</sub>		100		120	ns
$\overline{OE}$ to output delay	t <sub>OE</sub>		30		30	ns
Output enable high to output float	t <sub>DF</sub>	0	30	0	30	ns
Address to output hold	t <sub>OH</sub>	0		0		ns

**AC TEST CONDITIONS**

PARAMETER	MODE
Input voltage amplitude	0 V to 3 V
Input rise/fall time	≤ 10 ns
Input reference level	1 V, 2 V
Output reference level	0.8 V, 2 V

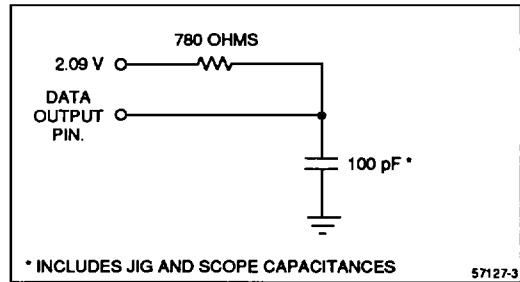

**Figure 3. Output Load Circuit**

**CAPACITANCE (T<sub>A</sub> = 25°C, f = 1MHz)**

PARAMETER	SYMBOL	CONDITIONS	MIN.	TYP.	MAX.	UNIT
Input capacitance	C <sub>IN</sub>	V <sub>IN</sub> = 0 V		4	6	pF
Output capacitance	C <sub>OUT</sub>	V <sub>OUT</sub> = 0 V		8	12	pF

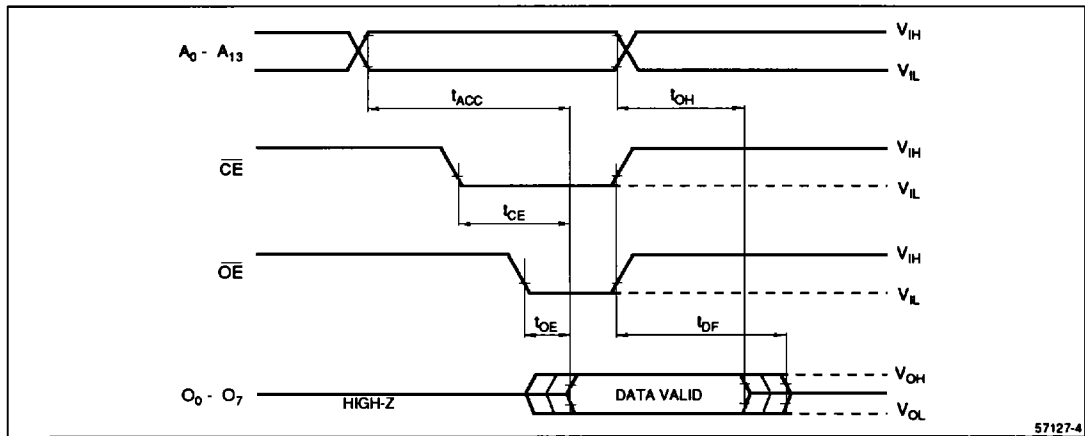

**Figure 4. Timing Diagram (Read Mode)**

**RECOMMENDED OPERATING CONDITIONS (Program Mode) (T<sub>A</sub> = 25°C ± 5°C)**

PARAMETER	SYMBOL	MIN.	TYP.	MAX.	UNIT
Supply voltage	V <sub>CC</sub>	5.75	6.0	6.25	V
	V <sub>PP</sub>	12.2	12.5	12.8	
Input "Low" voltage	V <sub>IL</sub>	-0.1		0.45	V
Input "High" voltage	V <sub>IH</sub>	2.4		V <sub>CC</sub> + 0.3	V

**DC CHARACTERISTICS (Program Mode)**(V<sub>CC</sub> = 6.0 V ± 0.25 V, V<sub>PP</sub> = 12.5 V ± 0.3 V, T<sub>A</sub> = 25°C ± 5°C)

PARAMETER	SYMBOL	CONDITIONS	MIN.	TYP.	MAX.	UNIT
Input leakage current	I <sub>LI</sub>	V <sub>IN</sub> = V <sub>CC</sub> or 0.45 V	-10		10	μA
V <sub>CC</sub> supply current	I <sub>CC</sub>				60	mA
V <sub>PP</sub> supply current	I <sub>PP</sub>	CE = PGM = V <sub>IL</sub>			50	mA
Input "Low" voltage	V <sub>IL</sub>		-0.1		0.45	V
Input "High" voltage	V <sub>IH</sub>		2.4		V <sub>CC</sub> + 0.3	V
Output "Low" voltage	V <sub>OL</sub>	I <sub>OL</sub> = 2.1 mA			0.45	V
Output "High" voltage	V <sub>OH</sub>	I <sub>OH</sub> = -400 μA	2.4			V

**AC CHARACTERISTICS (Program Mode)**(V<sub>CC</sub> = 6.0 V ± 0.25 V, V<sub>PP</sub> = 12.5 V ± 0.3 V, T<sub>A</sub> = 25°C ± 5°C)

PARAMETER	SYMBOL	MIN.	TYP.	MAX.	UNIT
Address setup time	t <sub>AS</sub>	2			μs
Chip enable setup time	t <sub>CES</sub>	2			μs
Output enable setup time	t <sub>OES</sub>	2			μs
Data setup time	t <sub>DS</sub>	2			μs
Address hold time	t <sub>AH</sub>	0			μs
Data hold time	t <sub>DH</sub>	2			μs
Chip enable to output float delay	t <sub>DF</sub>	0		150	ns
Data valid from output enable	t <sub>OE</sub>			150	ns
V <sub>PP</sub> setup time	t <sub>VPS</sub>	2			μs
V <sub>CC</sub> setup time	t <sub>VCS</sub>	2			μs
Program pulse width	t <sub>PW</sub>	0.95	1	1.05	ms
Add PGM pulse width*	t <sub>OPW</sub>	2.85		78.75	ms
Program pulse count	N	1		25	TIMES

\* This width is defined by the Program Flowchart (Figure 6).

## PROGRAMMING

Upon delivery from SHARP or after each erasure (see erasure section), the LH57127 and LH57127J have all  $16,384 \times 8$  bits in the "1", or high state. "0"s are loaded into the LH57127 and LH57127J through the procedure of programming.

The programming mode is entered when +12.5 V is applied to the  $V_{PP}$  pin and  $\overline{CE}$  is at  $V_{IL}$ . A 0.1  $\mu$ F capacitor between  $V_{PP}$  and GND is needed to prevent excessive voltage transients, which could damage the device. The address to be programmed is applied to the proper address pins. 8-bit patterns are placed on the respective data pins. The voltage levels should be standard TTL levels.

## ERASURE

In order to clear all locations of their programmed contents, it is necessary to expose the LH57127J to an ultra-violet light source. A dosage of 15 W-second/cm<sup>2</sup> is required to completely erase an LH57127J. This dosage can be obtained by exposure to an ultra-violet lamp (wave-length of 2,537 Angstroms (Å)) with intensity of 12,000  $\mu$ W/cm<sup>2</sup> for 20 to 30 minutes. The LH57127J should be about one inch from the source and all filters should be removed from the UV light source prior to erasure.

It is important to note that the LH57127J and similar devices will erase with light sources having wave-length shorter than 4,000 Å.

Although erasure times will be much longer than with UV sources at 2,537 Å, the exposure to fluorescent light and sunlight will eventually erase the LH57127J and exposure to them should be prevented to realize maximum system reliability. If used in such an environment, the package windows should be covered by an opaque label or substance.

## CAUTION

Fluorescent light and sunlight contain UV rays which will erase the EPROM. To prevent deterioration of EPROM data due to UV rays, it is recommended that EPROMs should not be left under direct sunlight or fluorescent light, or the package window should be covered with an opaque material.

Care must be taken to avoid friction between package window and plastics or the like, as the resulting static-electric build-up may cause faulty operation.

1.  $V_{CC}$  must be applied either coincidentally or before  $V_{PP}$  and removed either coincidentally or after  $V_{PP}$ .
2.  $V_{PP}$  must not be greater than 13.5 volts including overshoot.
3. During  $\overline{CE} = \overline{PGM} = V_{IL}$ ,  $V_{PP}$  must not be switched from 5 volts to 12.5 volts or vice-versa.
4. Removing or inserting the device while 12.5 volts is supplied may harm the reliability of the device.

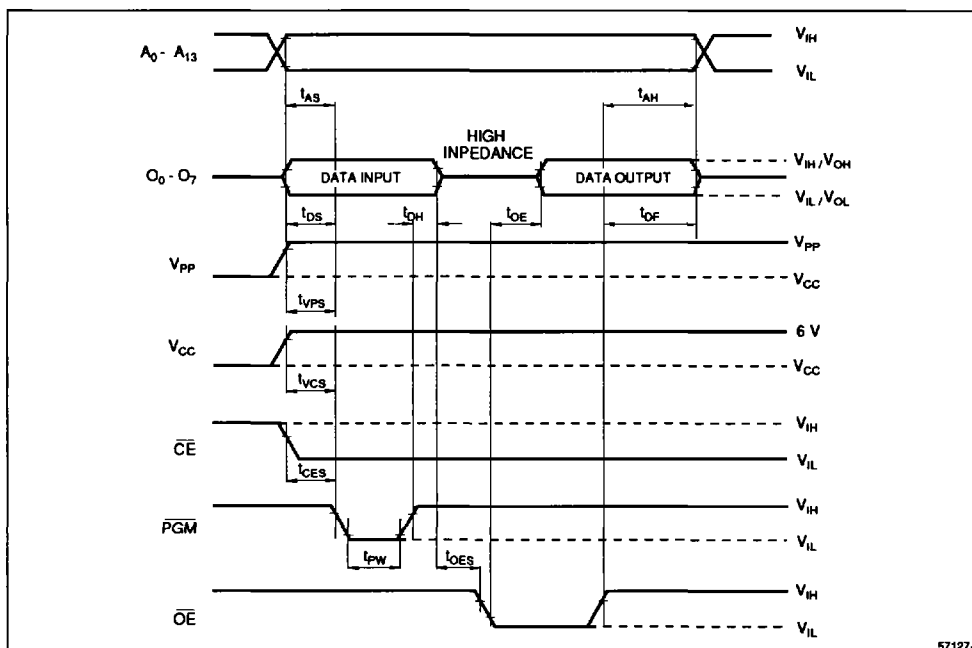

Figure 5. Timing Diagram (Program Mode)

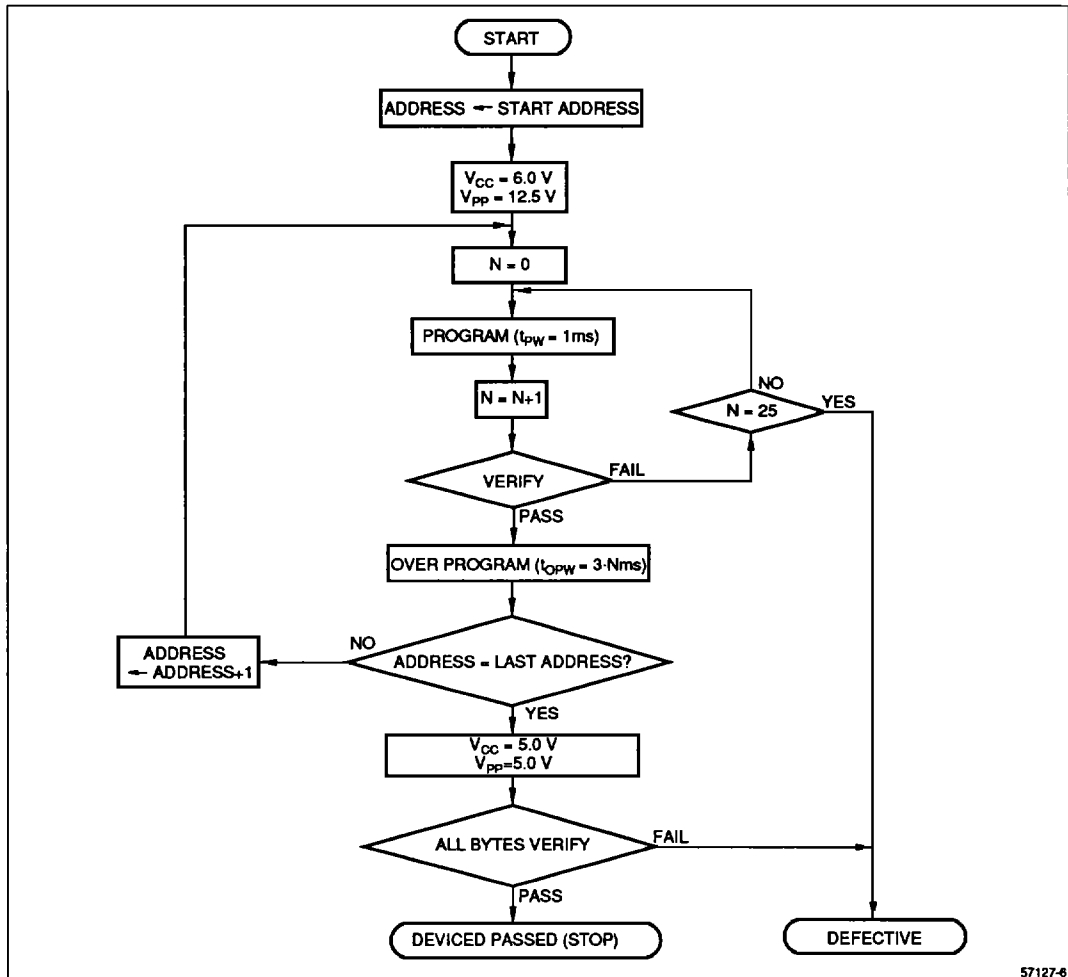
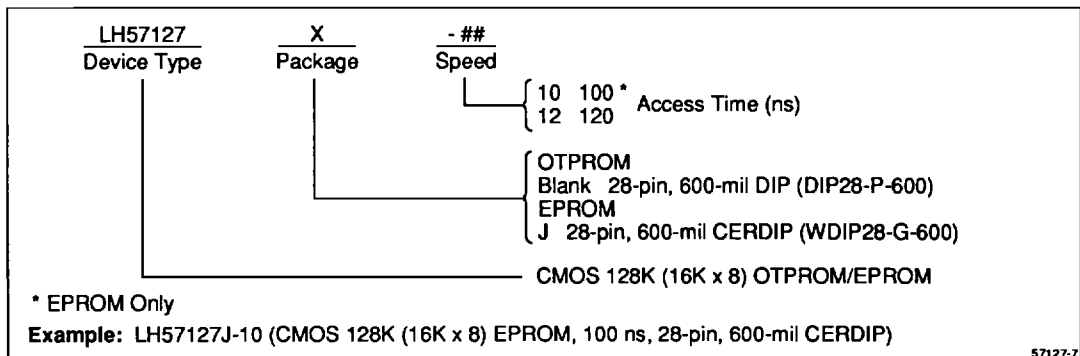

Figure 6. Programming Flowchart

ORDERING INFORMATION



57127-7