

MTC-20276

MTC-20277

Integrated NT1 (INT)
for Basic Rate ISDN

Integrated Basic Rate
ISDN Network Terminator (INT)

Data Sheet

Preliminary

Key Features:

- ▼ ISDN basic rate NT functions in a single monolithic integrated circuit
- ▼ U and S/T interfaces in one device
- ▼ Minimal external components
- ▼ 3.3V operating voltage for low power operation
- ▼ Pin compatible 2B1Q and 4B3T line code versions
 - * MTC-20276 INTQ for 2B1Q
 - * MTC-20277 INTT for 4B3T
- ▼ Standing alone mode for standard NT1 applications
- ▼ Standard GCI bus interface for advanced functions
- ▼ 330mW maximum power consumption
- ▼ Dual power monitor inputs
- ▼ Flashing LED status indicator
- ▼ -40°C to + 85°C operation
- ▼ 44 pin Plastic Quad Flat Pack package

Applications

- ▼ Line powered ISDN NT
- ▼ Micro PABX
- ▼ NT plus
- ▼ Data Network Gateways
- ▼ Pair gain

General Description Basic Rate

The MTC-20276/7 chip contains all the functions necessary to make an ISDN Network Termination module. It comprises a fully integrated 'U'-interface, and 'S'-interface, plus the necessary support functions. The general block diagram is shown in Figure 1. Two versions of the device are available - the MTC-20276 offering the 2B1Q line code on the U interface, and the MTC-20277 which has 4B3T line coding. The two devices are pin compatible, and are fully compliant with the relevant parts of ANSI, ETSI and FTZ and ITU requirements for ISDN connection.

The MTC-20276/7 devices offer a user transport rate of 144kbit/s full duplex (2B + D), as well as fully automatic control of activate/deactivate protocols and full support of the maintenance channel.

The devices are fabricated in Mietec's advance 0.5µ CMOS mixed digital analog process and operate with single 3.3V supply voltage.

A JTAG port provides advanced test access while a GCI bus interface supports expanded features including data ports and A/B (POTS) analog ports.

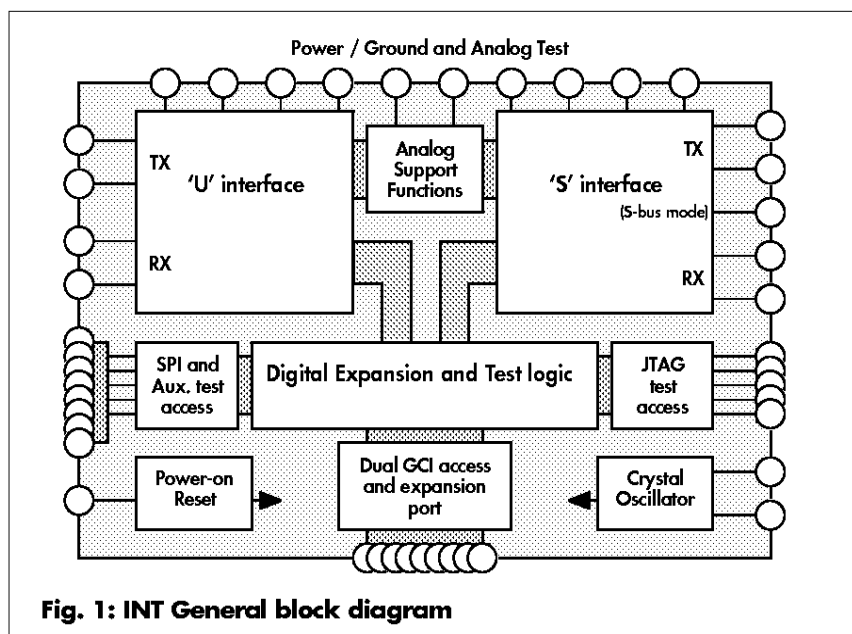

Fig. 1: INT General block diagram

NT and Extended NT Functions (“NTplus”)

The MTC-20276/7 has a number of test access ports to facilitate production testing. One of these ports is configured as a dual GCI interface, which operates in one of two modes. In Mode 0, the GCI port allows the data flow between the 'U' and the 'S' ports to be optionally monitored. This is the “alone” mode, which is the normal mode for simple NT1 applications. No additional microprocessor or other control device is required in this mode.

Mode 1 allows separate access to the 'U' and the 'S' ports, for use by an external GCI compatible controller device. In this mode, the chip supports additional features required by extended NT modules (“NT1+”) such as interfaces to existing analog equipment, or advanced data communication gateways.

Figure 2 shows the circuit configuration of the MTC-20276/7 in its stand alone mode, for conventional NT1 applications.

Figure 3 shows the system concept of an MTC-20276/7 in an “NT1+” application, in combination with the Mietec MTK-40131 “SH-POTS” chipset for short-haul analog telephone lines, and a User-specified IC (USIC) which performs the necessary control and interface functions.

When using the MTC-20276 in a 2B1Q NT module, two test pins AUX1 and AUX2 are used to flag the status of the power supplies to the module: AUX1 (PW220) is used to indicate the presence of a mains or other local supply voltage (1 = local supply available), and AUX2 (PW40) is used to indicate the presence of a supply voltage from the 'U' interface line (40V nominal, 1 = line power available). To ensure pin compatibility between the 2B1Q and 4B3T versions, these pins are ignored in the MTC-20277 for 4B3T NT modules.

MTC-20276 MTC-20277

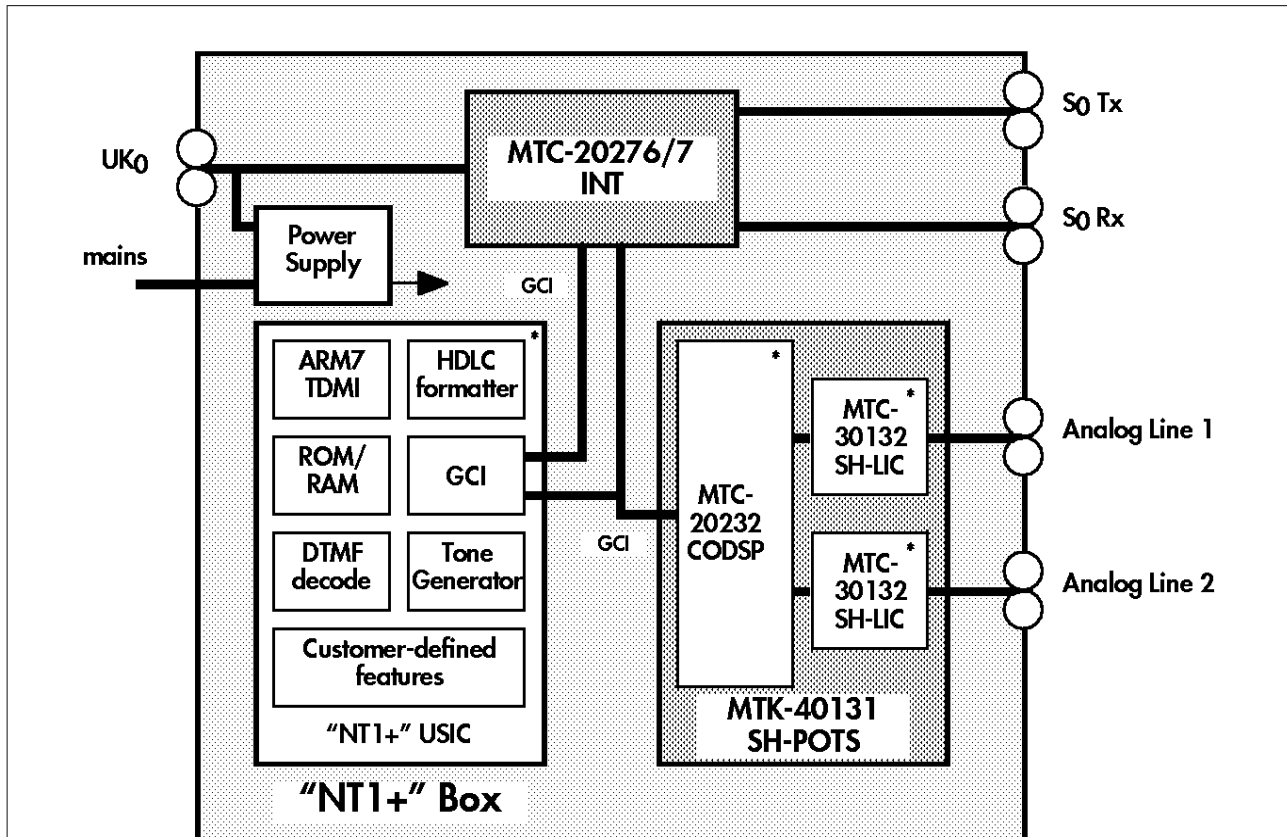

Fig. 3: Concept of an NT1+ Configuration for 2 Analog Lines

* Future products

Pin Description

Nr.	Function	Name	Dir.	Description
44 1	U	LOUT1	○	U interface analog outputs. The connections LOUT1 and LOUT2 interface the U driver outputs, via termination resistors and the line coupling transformer, to the UKO reference point.
		LOUT2	○	
3	Int.	LIN1		U interface analog inputs to the INT from the analog 'hybrid'
4		LIN2		
2		AREF	○	Analog ground (1.65V). Used as reference voltage for analog functions
43		AVDD	P	VDD for analog U interface functions
42		AVSS	P	VSS (0V ground) for U interface analog functions
33 32		SXP	○	S interface analog outputs. SXP and SXN interface the S-driver outputs via terminating resistors and the TX line coupling transformer to the SO reference point (Tx).
		SXN	○	
31	S	SRP		S interface analog inputs. SRP and SRN interface the S inputs via a line coupling transformer to the SO interface point (Rx).
30		SRN		
37	Int.	SBUS		S-bus type configuration. 1 = short bus with fixed timing, 0 = adaptive timing for extended bus or point-to-point

MTC-20276
MTC-20277

34		SATP	○	Analog test pin. Used for test purposes only, should be left open.
36		AVDD	P	VDD for analog S interface functions
35		AVSS	P	VSS (0V ground) for S interface analog functions
12	GCI	G1DOUT	○	Primary GCI interface G1: GMODE = 0 : Monitoring of the internal GCI between the U and S. GMODE = 1 : NTplus mode; complete GCI connected to U with U as master.
13		G1DIN		
14		G1DCLK	○	
15		G1DFR	○	
18	Int.	G2DOUT	○	Secondary GCI interface G2: GMODE = 0 : No function GMODE = 1 : NTplus mode; complete GCI connected to S with external master.
19		G2DIN		
20		G2DCLK	○	
21		G2FR	○	
22		GMODE		Select NTplus mode. 0 = monitoring mode, 1 = NTplus mode.
5	JTAG	TRST		TAP controller reset, active low
6		TCK		TAP controller clock, maximum 10 MHz
7		TMS		TAP controller mode selection
8	INT.	TDI		TAP controller input
9		TDO	○	TAP controller output
41		NRESET		Hardware reset, active low. Schmitt trigger input for connection to external RC or logic device. Reset pulse min. 10ms.
25		XTAL1		Connection to external crystal
24		XTAL2		Connection to external crystal. May also be used as input for external master clock source
40		TSP		Test Single Pulses. INT transmits alternate positive and negative pulses to act as test and search-tone on the line.
39		AUX1/ PW220		MTC-20276. Test input only (strap to ground)
38		AUX2/ PW40		MTC-20277. Indicate presence of 220V AC supply. 1 = 220V is ON MTC-20276. Test input only (strap to ground) MTC-20277. Indicate presence of 40V power from line. 1 = 40V is ON
10	SPI Int.	SPICK	○	SPI interface provided for test purposes only SPIDI must be strapped to ground for normal operation
11		SPICS	○	
27		SPIDI		
28		SPIDO	○	
29		AUX		Test purposes only. Must be strapped to ground for normal operation
16		VDD	P	Positive supply for digital functions
26		VDD	P	
17		VSS	P	0V ground for digital functions
23		VSS	P	

MTC-20276 MTC-20277

Absolute Maximum Ratings	
Operation at these limits is not guaranteed, and device reliability will be adversely effected.	
Logic supply voltage (VDD, AVDD)	6 V
Voltage on any pin (except GCI)	VDD+0.3 V VSS-0.3 V
Voltage on GCI interface pins	6 V
Continuous power dissipation	1 W at 25 °C ambient
Storage temperature	-55 to +150 °C for < 100 hours -55 to +100 °C for > 100 hours
Operating Ranges	
VDD, AVDD	3.15 to 3.45 V (= 3.3V ± 5%)
Supply noise (p-p):	≤ 100mV on VDD ≤ 10mV on AVDD ≤ 0.1mV on AREF
AREF output voltage	1.65V ± 3%
Max current on AREF	+ or - 0.25 mA
Power consumption	≤330 mW in power-up state, nominal loads on S and U interfaces, random signals: U: 150Ω line equivalent S: 100Ω line equivalent ≤10mW in power-down state
Crystal frequency	15.36 MHz ± 10ppm. Parallel mode NT cut crystal, loading capacitors 2 x 20 pF. External master clock may be applied to XTAL2.
Temperature range	-40 to +85 °C
Reliability Information	
Early failure rate	≤0.3% at 3000 hours
Long term failure rate	≤ 300 FIT for 45°C average ambient and 45% average humidity
Lifetime	≥ 15 years
Ordering Information	
MTC-20276-PC INTQ	INT for 2B1Q line code, 44PLCC package style
MTC-20276-PQ INTQ	INT for 2B1Q line code, 44PQFP package style
MTC-20277-PC INTT	INT for 4B3T line code, 44PLCC package style

This document contains information on a new product. Alcatel Mietec reserves the right to make changes in specifications at any time and without notice.

The information furnished by Alcatel Mietec in this document is believed to be accurate and reliable. However, no responsibility is assumed by Alcatel Mietec for its use, nor for any infringements of patents or

other rights of third parties resulting from its use. No licence is granted under any patents or patent rights of Alcatel Mietec.

Alcatel Mietec Sales Offices

Central Europe

Arabellastraße 4
81925 München
DEUTSCHLAND

Tel. [089] 920 07 70
Fax [089] 910 15 59

Northern Europe

Centennial Court
Easthampstead Road
Bracknell - Berkshire
RG12 1YQ / UK

Tel. [1344] 30 03 11
Fax [1344] 30 07 97

Southern Europe

10, rue Latécoère,
B.P. 57
78140 Vélizy Cedex
FRANCE

Tel. [1] 46 32 53 86
Fax [1] 46 32 55 68

Italy

Via Magenta 44/A
10128 Torino
ITALY

Tel. [011] 56 11 550
Fax [011] 53 39 02

USA

1200 N. Alma Rd
Richardson, TX 75081
Tel. [214] 996 5000
Fax [214] 996 7062

270 E. Brokaw Rd
San Jose, CA95112
Tel. [408] 441 1590

Marketing & Design Centre

Raketstraat 62
1130 Brussels
BELGIUM

Tel. [02] 728 18 11
Fax [02] 726 42 15
e-mail info@mietec.be

Headquarters Manufacturing Customer Service

Westerring 15
9700 Oudenaarde
BELGIUM

Tel. [055] 33 24 70
Fax [055] 33 27 68

