

Thin-Film Cascadable Amplifier 10 to 1000 MHz

Technical Data

UTO/UTC 1024 Series

Features

- **Frequency Range: 10 to 1000MHz**
- **High Power Output: +24dBm (Typ)**
- **Medium Gain: 13.0 dB (Typ)**
- **Temperature Compensated**

Applications

- **IF/RF Amplification**
- **Output Stage**

Description

The 1024 Series is a thin-film bipolar RF amplifier for higher output power and medium-gain applications up to 1000 MHz. Resistive feedback and active bias assure temperature compensation and increased immunity to bias voltage variations. Low VSWR is maintained by inductive tuning while the RF is coupled through the amplifier by internal blocking capacitors. The 1024 Series amplifiers are available in either the TO-8 hermetic case or connected TC-1 package.

Pin Configuration UTO—TO-8T

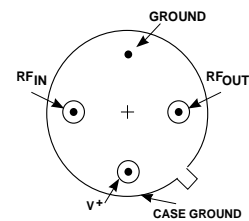

UTC—TC-1

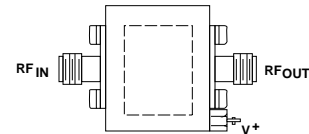

Schematic

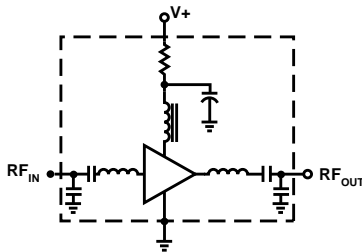

Maximum Ratings

Parameter	Maximum
DC Voltage	+17 Volts
Continuous RF Input Power	+14 dBm
Operating Case Temperature	-55 to +100°C
Storage Temperature	-62 to +150°C
"R" Series Burn-In Temperature	+100°C

Thermal Characteristics¹

θ_{JC}	72/52/52°C/W ²
Active Transistor Power Dissipation	663/498/498 mW ²
Junction Temperature Above Case Temperature	48/26/26°C ²
MTBF (MIL-HDBK-217E, A_{UF} @ 90°C)	454,100 Hrs.

Notes:

1. For further information, see Reliability Screening, Pub. 5963-3240E.
2. Values refer to first, second, and third stages, respectively.

Weight: (typical) UTO—2.1 grams; UTC—21.5 grams

Electrical Specifications

(Measured in 50 Ω system @ +15 VDC nominal unless otherwise noted)

Symbol	Characteristic	Typical $T_c = 25^\circ\text{C}$	Guaranteed Specifications		Unit
			$T_c = 0 \text{ to } 50^\circ\text{C}$	$T_c = -55 \text{ to } +85^\circ\text{C}$	
BW	Frequency Range	10-1000	10-1000	10-1000	MHz
GP	Small Signal Gain (Min.)	13.0	12.0	12.0	dB
—	Gain Flatness (Max.)	± 0.2	± 1.0	± 1.0	dB
NF	Noise Figure (Max.)	5.5	6.5	7.0	dB
P_{1dB}	Power Output @ +1 dB Comp. (Min.)				
	10-500 MHz (Min.)	+26.0	+24.5	+24.0	dBm
	500-1000 MHz (Min.)	+24.0	+22.0	+21.5	dBm
—	Input VSWR (Max.)	1.5:1	2.0:1	2.0:1	—
—	Output VSWR (Max.)	1.5:1	2.0:1	2.0:1	—
IP_3	Two Tone 3rd Order Intercept Point	+35.0	—	—	dBm
IP_2	Two Tone 2nd Order Intercept Point	+42.0	—	—	dBm
HP_2	One Tone 2nd Harmonic Intercept Point	+48.0	—	—	dBm
I_D	DC Current	155	—	—	mA

Typical Performance Over Temperature (@ +15 VDC unless otherwise noted)

Key: +25°C —
+85°C - -
-55°C —

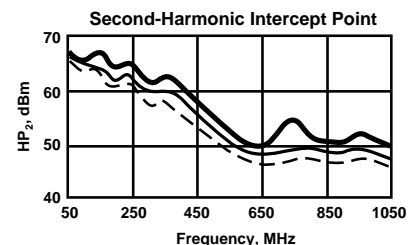
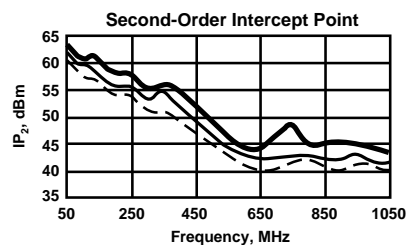
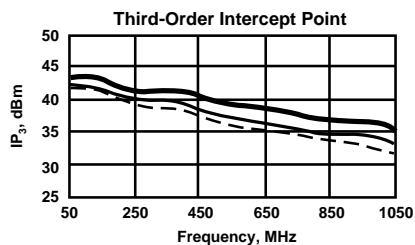
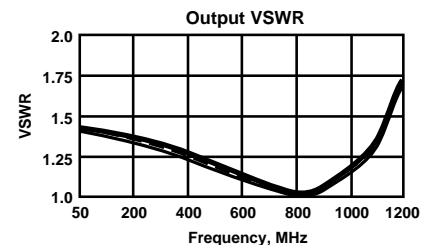
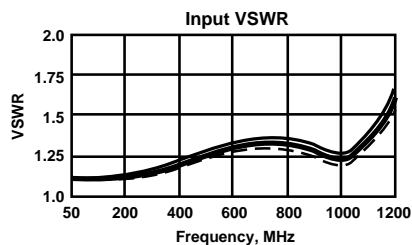
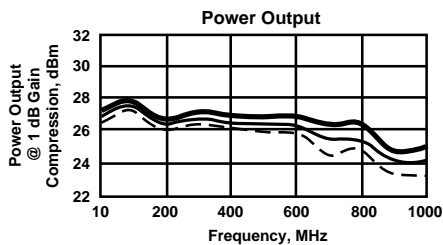
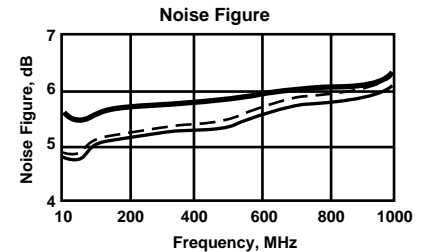
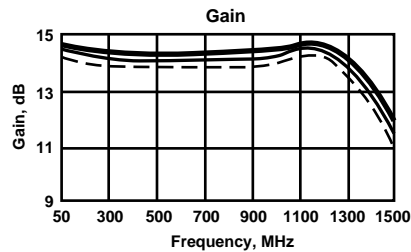

Automatic Network Analyzer Measurements (Typical production unit @ +25°C ambient)

S-Parameters
Bias = 15.00 Volts

FREQ GHz	S ₁₁		S ₂₁		S ₁₂		S ₂₂		GPDEL ns	PHASE DEG
	Mag	Ang	dB	Ang	dB	Ang	Mag	Ang		
.05	.03	-75.5	14.0	173.0	-20.3	-3.0	.17	167.95	.56	.28
.10	.03	-81.5	14.0	163.1	-20.3	-8.4	.17	162.02	.56	-.67
.15	.04	-84.5	13.9	153.6	-20.3	-13.5	.16	155.20	.51	-.83
.20	.04	-87.2	13.9	144.8	-20.4	-18.2	.15	148.08	.50	-.83
.25	.05	-88.2	13.9	135.9	-20.4	-23.1	.14	140.82	.50	-.69
.30	.06	-90.3	13.8	127.2	-20.4	-27.8	.13	133.74	.48	-.39
.35	.07	-92.6	13.8	118.4	-20.4	-32.6	.12	126.79	.49	-.15
.40	.09	-95.1	13.8	109.6	-20.4	-37.6	.11	119.60	.49	.11
.45	.10	-97.2	13.8	100.8	-20.4	-42.3	.09	112.39	.49	.36
.50	.11	-100.0	13.7	52.0	-20.4	-47.3	.08	104.69	.49	.63
.55	.12	-103.2	13.7	83.3	-20.5	-52.5	.06	97.15	.48	.93
.60	.13	-106.0	13.7	74.5	-20.5	-57.4	.04	88.39	.49	1.13
.65	.14	-108.9	13.7	65.4	-20.5	-62.7	.03	78.21	.50	1.12
.70	.14	-111.7	13.7	56.4	-20.5	-69.0	.02	63.26	.50	1.20
.75	.14	-114.1	13.7	47.3	-20.5	-73.4	.01	30.59	.51	1.06
.80	.14	-115.4	13.8	38.0	-20.5	-79.3	.00	-67.33	.51	.84
.85	.14	-115.6	13.8	28.5	-20.5	-85.1	.00	-142.32	.53	.41
.90	.13	-113.5	13.9	-18.7	-20.4	-91.2	.01	116.90	.54	-.34
.95	.12	-107.5	13.9	8.7	-20.4	-97.6	.02	85.99	.56	-1.38
1.00	.12	-97.0	14.0	-1.8	-20.4	-104.7	.05	70.20	.59	-2.80
1.10	.15	-69.6	14.1	-24.2	-20.4	-119.7	.13	46.32	.64	
1.20	.26	-80.7	14.0	-49.0	-20.6	-136.9	.26	24.62	.70	
1.30	.41	-68.1	13.4	-75.7	-21.3	-155.7	.42	2.25	.75	
1.40	.57	-82.1	12.4	-102.8	-22.5	-174.6	.58	-20.06	.75	
1.50	.68	-97.2	10.8	-128.5	-24.2	168.9	.70	-40.77	.70	
1.60	.74	-111.2	8.9	-151.9	-26.5	156.4	.78	-59.50	.63	
1.70	.76	-123.5	7.0	-173.0	-28.8	150.5	.82	-75.96	.57	
1.80	.76	-133.7	5.2	167.2	-30.4	154.2	.82	-90.25	.54	
1.90	.72	-141.3	3.7	147.2	-30.2	159.7	.80	-102.36	.57	
2.00	.69	-145.7	2.2	124.4	-28.7	155.8	.79	-112.25	.66	
2.10	.67	-146.7	.1	97.2	-27.6	144.9	.79	-121.69	.77	
2.20	.70	-147.0	-3.1	69.9	-27.1	131.5	.79	-131.24	.73	
2.30	.75	-150.1	-7.4	48.7	-27.1	118.8	.80	-140.87	.53	
2.40	.80	-155.5	-12.0	36.0	-27.1	106.5	.81	-150.78	.29	
2.50	.83	-161.6	-16.2	31.6	-27.4	94.3	.82	-160.49	.08	

LINEARIZATION RANGE: .05 to 1.00 GHz

Product Options

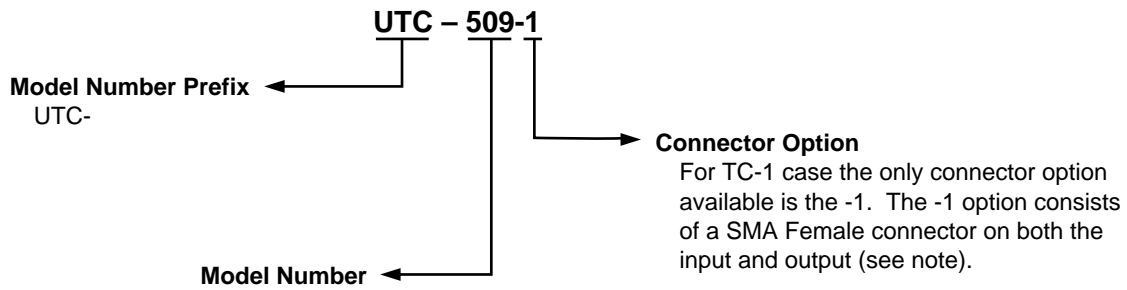
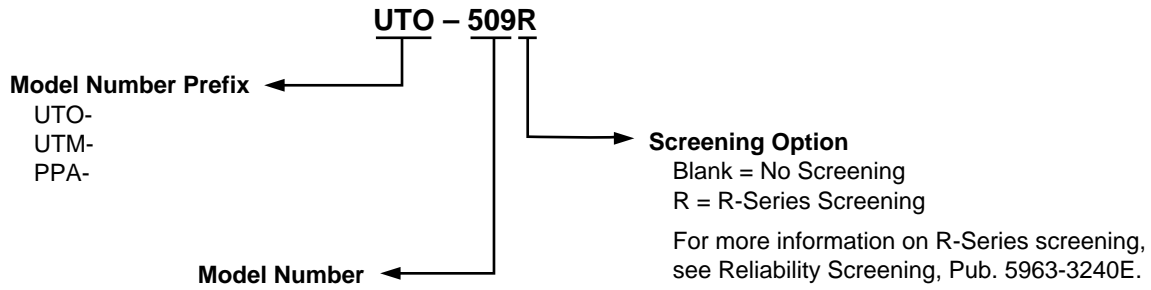

Note: R-Series screening is not available in the TC-1 case as the case is non-hermetic.

**Case Drawings
TO-8T**

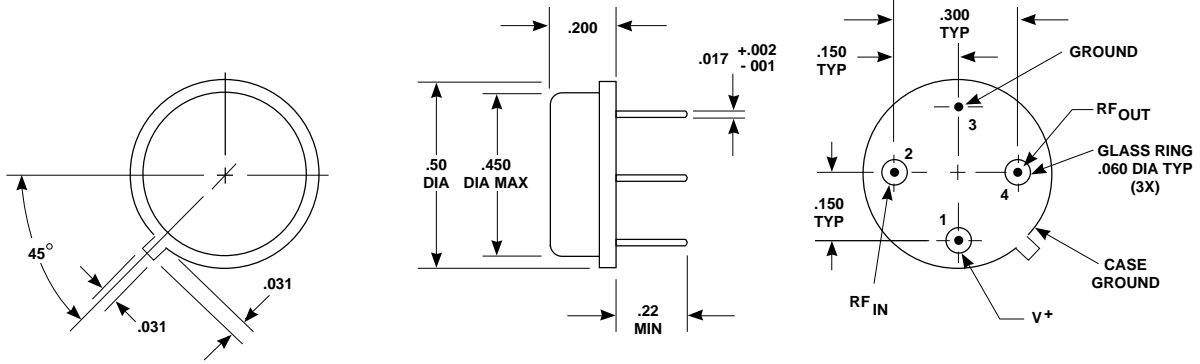

APPROXIMATE WEIGHT 2.1 GRAMS

- NOTES (UNLESS OTHERWISE SPECIFIED):**
 1. DIMENSIONS ARE SPECIFIED IN INCHES
 2. TOLERANCES: xx ± .02
 xxx ± .010

Case Drawings TC-1

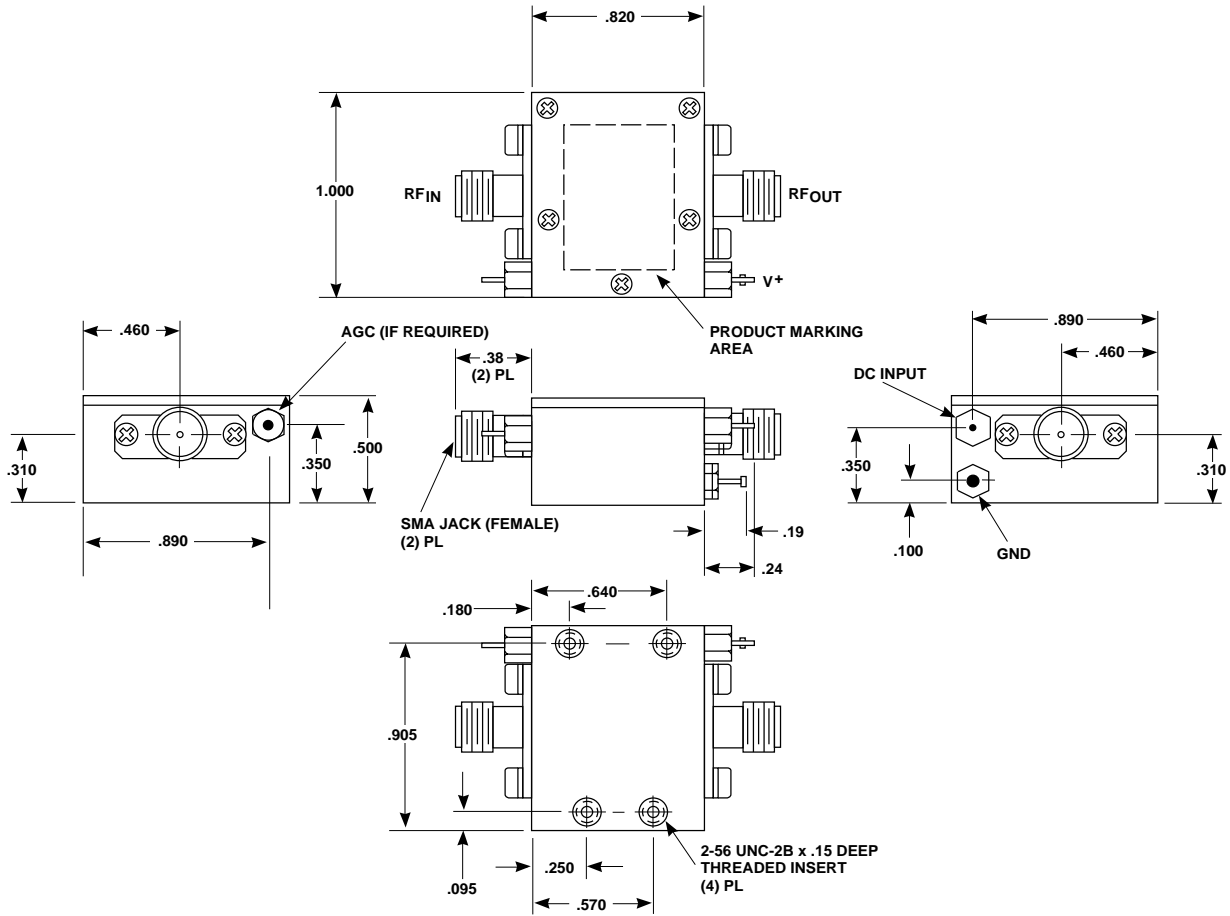

TYPICAL WEIGHT WITH CONNECTORS = 21.5 GRAMS

- NOTES: 1. THE TC-1 CASE IS A NON-HERMETIC CASE.
2. THE ONLY CONNECTOR OPTION AVAILABLE FOR THE TC-1 CASE IS THE -1, SMA FEMALE CONNECTORS AT BOTH INPUT AND OUTPUT PORTS.

- NOTES (UNLESS OTHERWISE SPECIFIED):
1. DIMENSIONS ARE SPECIFIED IN INCHES
2. TOLERANCES: xx ± .02
xxx ± .010

For more information:

United States*

Europe*

Far East/Australasia: (65) 290-6305

Canada: (416) 206-4725

Japan: (81 3) 3331-6111

*Call your local HP sales office listed in your telephone directory. Ask for a Components representative.

Data Subject to Change
Copyright © 1995 Hewlett-Packard Co.

Printed in U.S.A. 5963-2527E (10/94)