

THIS DRAWING IS UNPUBLISHED. RELEASED FOR PUBLICATION
 © COPYRIGHT BY TYCO ELECTRONICS CORPORATION. ALL RIGHTS RESERVED.

LOC	DIST	REVISIONS					
G	14	P	LTR	DESCRIPTION	DATE	DWN	APVD
			H	REV PER 0G3A-0644-04	17AUG04	JR	TM

AMP WIRE RANGE	Listed FILE E13288	LR7189 Certified
22-16 AWG SOLID OR STRANDED	22-16 AWG SOLID OR STRANDED	22-16 AWG SOLID OR STRANDED

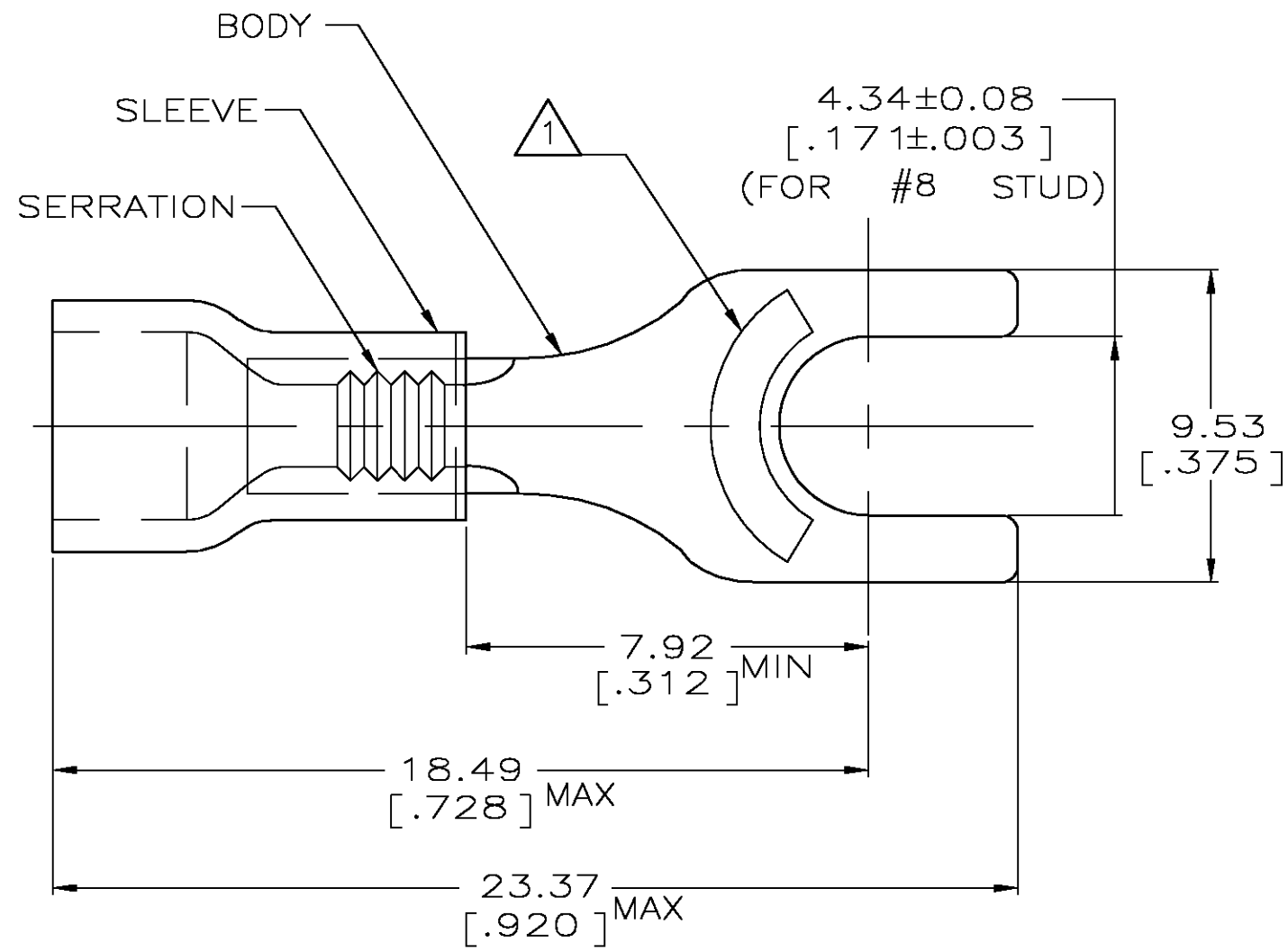

- △1 STAMP AMP 22-18* APPROX AS SHOWN
22-16 TERMINALS ARE STAMPED 22-18 IN
ACCORDANCE WITH MILITARY SPEC MIL-T-7928
COMMERCIAL WIRE RANGE IS 22-16
- 2. WIRE INSUL DIA, 2.67 TO 3.56 [.105 TO .140]
- 3. TONGUE MATL THK, 0.79±0.05 [.031±.002]
- △4 SUPERSEDED BY 8-34155-5
- △5 MATERIAL: BODY - CU PER ASTM B152
SLEEVE - PVC, COLOR - RED

△4	50	LOOSE PIECE, BAG	8-34155-5
	5	LOOSE PIECE, BLS	8-34155-4
	100	LOOSE PIECE, BOX	8-34155-1
	5000	ON TAPE, REEL	2-34155-1
	1000	LOOSE PIECE	34155
	QTY	PACKAGE TYPE	PART NO

AMP INCORPORATED CUSTOMER SERVICE SYSTEMS		MAX RECOMMENDED OPERATING TEMPERATURE: 105°C [221°F]	THIS DRAWING IS A CONTROLLED DOCUMENT.		DWN G VINSON 07NOV94	Tyco Electronics Corporation Harrisburg, Pa 17105-3608				
FOR ADDITIONAL PRODUCT INFORMATION OR COPIES OF DRAWINGS AND TECHNICAL DOCUMENTS	PRODUCT INFORMATION CENTER 1-800-522-6752	VOLTAGE RATING: 600V MAX (1000V FIXTURE OR SIGN)	DIMENSIONS: mm [INCHES]	TOLERANCES UNLESS OTHERWISE SPECIFIED:	CHK M ELLIS 07NOV94	NAME				
FOR APPLICATION TOOLING ASSISTANCE CENTER	TOOLING ASSISTANCE CENTER 1-800-722-1111	CIRCULAR MIL AREA: 0.26-1.65mm² [509-3260] SOLID OR STRANDED		0 PLC ± - 1 PLC ± - 2 PLC ± 0.20 [.008] 3 PLC ± - 4 PLC ± - ANGLES ± -	APVD G NGO 07NOV94	TERMINAL, SPADE, PLASTI-GRIP, WIRE SIZE: 22-16 AWG				
FOR ORDER ENTRY	1-800-526-5142	THIS DRAWING IS A CONTROLLED DOCUMENT FOR AMP INCORPORATED. IT IS SUBJECT TO CHANGE AND THE CONTROLLING ENGINEERING ORGANIZATION SHOULD BE CONTACTED FOR THE LATEST REVISION.	MATERIAL -5	FINISH -	PRODUCT SPEC UL 486A	SIZE A3	CAGE CODE 00779	DRAWING NO C-34155	RESTRICTED TO -	
					WEIGHT -	CUSTOMER DRAWING		SCALE 6:1	SHEET 1 OF 1	REV H