

Helping Customers Innovate, Improve & Grow

Features

- Any frequency between 1 MHz and 110 MHz accurate to 6 decimal places
- Low power consumption of 3.6 mA typical
- CMOS compatible output
- Industry-standard packages: 2.5 x 2.0, 3.2 x 2.5, 5.0 x 3.2, 7.0 x 5.0 mm

Applications

- Ideal for DSC, DVC, DVR, IP CAM, Tablets, e-Books, SSD, GPON, EPON
- Ideal for high-speed serial protocols such as: USB, SATA, SAS, Firewire, Ethernet, etc.

Performance Specifications

Parameter and Conditions	Symbol	Min.	Typ.	Max.	Unit	Condition
Output Frequency Range	f	1	–	110	MHz	
Frequency Stability	F_stab	-25	–	+25	PPM	Inclusive of Initial tolerance at 25°C, and variations over operating temperature, rated power supply voltage and load.
		-50	–	+50	PPM	
Aging	Ag	-1.5	–	1.5	PPM	1st year at 25°C
Operating Temperature Range	T_use	-20	–	+70	°C	Extended Commercial
		-40	–	+85	°C	Industrial
Supply Voltage	Vdd	1.62	1.8	1.98	V	Other supply voltages between 2.5V and 3.3V can be supported. Contact Vectron for additional information.
		2.25	2.5	2.75	V	
		2.52	2.8	3.08	V	
		2.7	3.0	3.3	V	
		2.97	3.3	3.63	V	
Current Consumption	Idd	–	3.9	4.5	mA	No load condition, f = 20 MHz, Vdd = 2.5V, 2.8V, 3.0V or 3.3V
		–	3.6	3.9	mA	No load condition, f = 20 MHz, Vdd = 1.8V
Standby Current	I_std	–	2.5	5	µA	ST = GND, Vdd = 3.0V or 3.3V, Output is Weakly Pulled Down
		–	2.5	5	µA	ST = GND, Vdd = 2.5V or 2.8V, Output is Weakly Pulled Down
		–	1	1.2	µA	ST = GND, Vdd = 1.8V, Output is Weakly Pulled Down
Duty Cycle	DC	45	–	55	%	All Vdds
Rise/Fall Time	Tr, Tf	–	1.2	2	ns	20% - 80% Vdd = 2.5V, 2.8V, 3.0V or 3.3V
		–	1.5	3	ns	20% - 80% Vdd = 1.8V
Output High Voltage	VOH	90%	–	–	Vdd	IOH = -4 mA (Vdd = 3.0V or 3.3V) IOH = -3 mA (Vdd = 2.8V and Vdd = 2.5V) IOH = -2 mA (Vdd = 1.8V)
Output Low Voltage	VOL	–	–	10%	Vdd	IOL = 4 mA (Vdd = 3.0V or 3.3V) IOL = 3 mA (Vdd = 2.8V and Vdd = 2.5V) IOL = 2 mA (Vdd = 1.8V)
Input High Voltage	VIH	70%	–	–	Vdd	Pin 1, OE or ST
Input Low Voltage	VIL	–	–	30%	Vdd	Pin 1, OE or ST
Input Pull-up Impedence	Z_in	–	100	250	kΩ	Pin 1, OE logic high or logic low, or ST logic high
		2	–	–	MΩ	Pin 1, ST logic low
Startup Time	T_start	–	–	5	ms	Measured from the time Vdd reaches its rated minimum value
Resume Time	T_resume	–	–	5	ms	Measured from the time ST pin crosses 50% threshold
RMS Period Jitter	T_jitt	–	2	3	ps	f = 20 MHz, Vdd = 2.5V, 2.8V, 3.0V or 3.3V
		–	2	4	ps	f = 20 MHz, Vdd = 1.8V
RMS Phase Jitter (random)	T_phj	–	1.5	2	ps	Integration bandwidth = 12 kHz to 20 MHz

Typical Phase Noise

Agilent E5052A Signal Source Analyzer

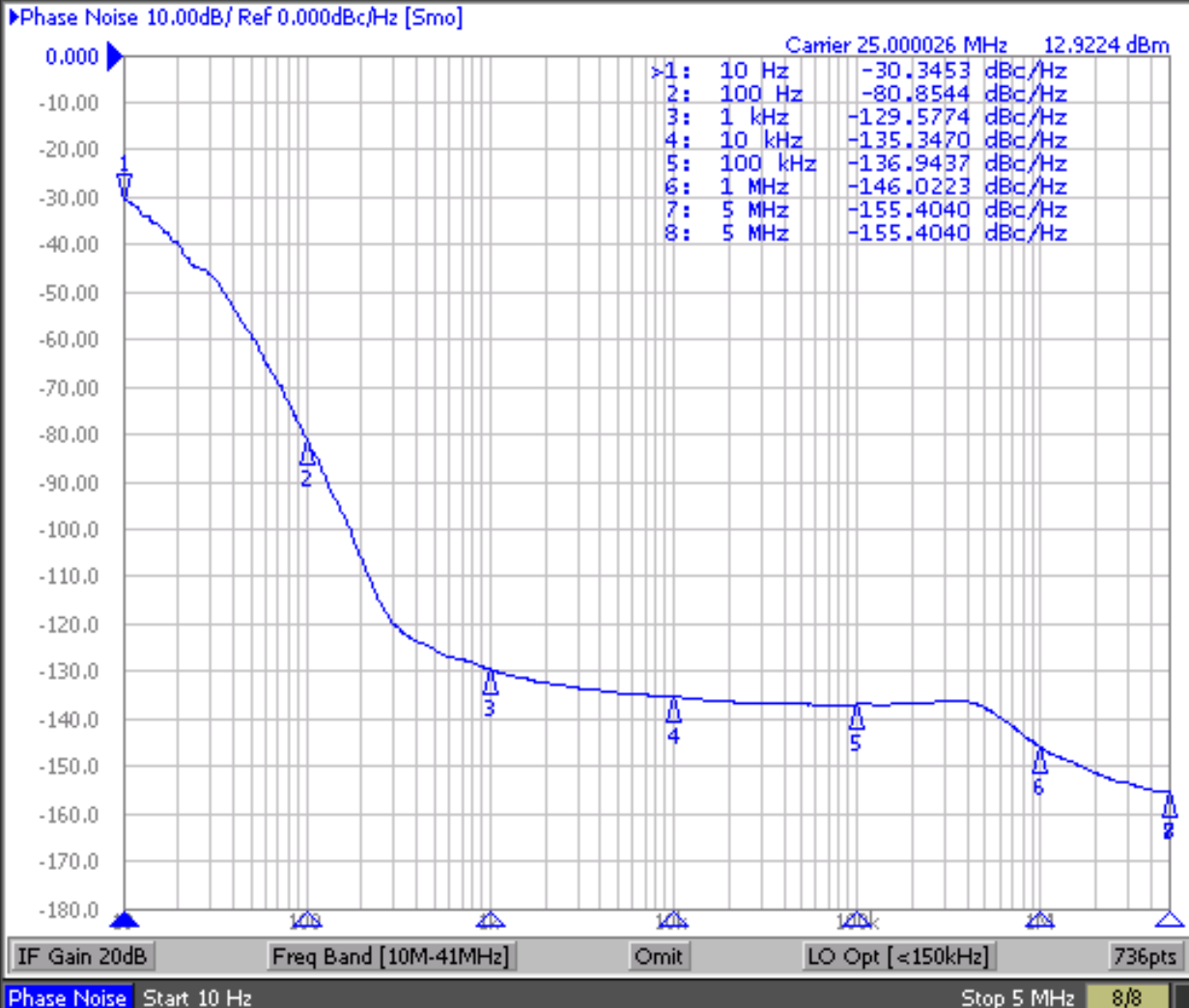

Save/Recall

Save State

Recall State

Recall by

File Name

Save
Data Trace ...

Save
Memory Trace ...

Explorer

Return

Phase Noise: Hold Cor Ctrl 1.65V Pow 3.3V Attn 10dB ExtRef Stop Svc 2012-12-20 11:46

Packaging Options

Package Outline & Dimensions (Unit: mm)

Recommended Land Pattern (Unit: mm)

2.5 x 2.0 x 0.75 mm

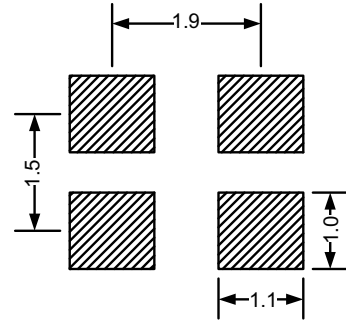
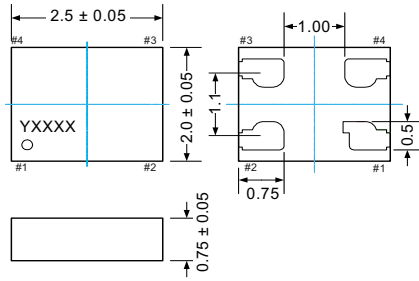

3.2 x 2.5 x 0.75 mm

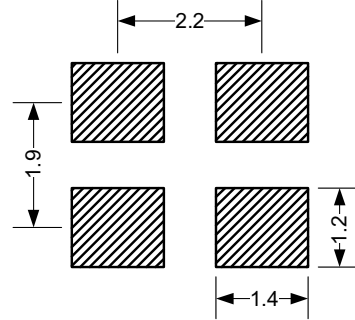
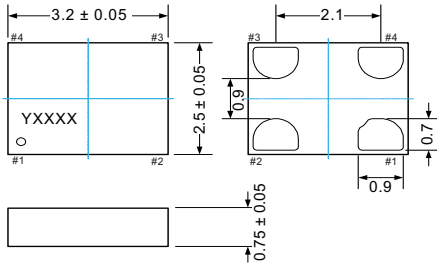

5.0 x 3.2 x 0.75 mm

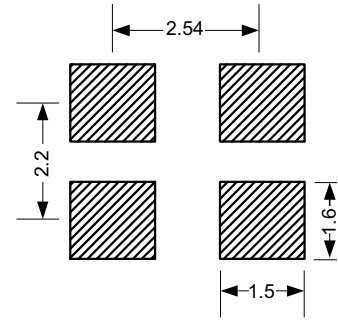
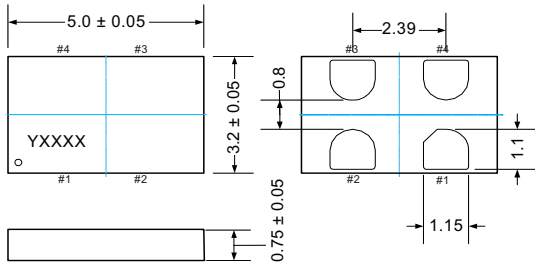

7.0 x 5.0 x 0.90 mm

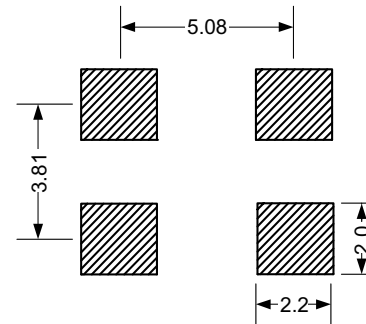
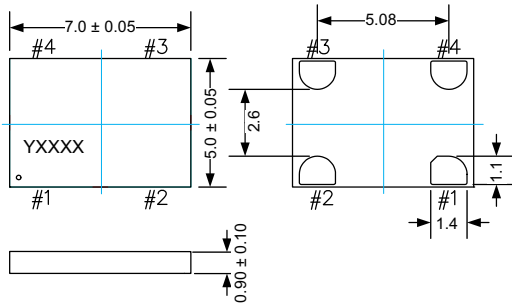

Pin Functionality

Pin Connections			
Pin	Symbol		Functionality
1	OE/ ST	Output Enable	H or Open*: specified frequency output L: output is high impedance. Only output driver is disabled.
		Standby	H or Open*: specified frequency output L: output is low (weak pull down). Device goes to sleep mode. Supply current reduces to I _{std} .
2	GND	Power	Electrical ground
3	OUT	Output	Oscillator output
4	VDD	Power	Power supply voltage

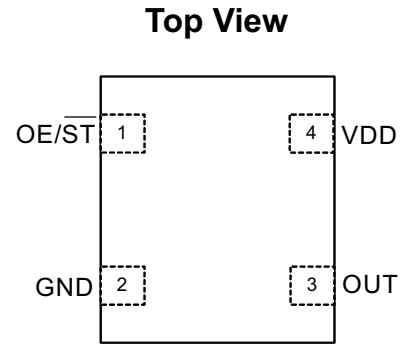

* A pull-up resistor of <10 kΩ between OE/ ST pin and Vdd is recommended in high noise environment

Environmental

Environmental Compliance	
Parameter	Condition/Test Method
Mechanical Shock	MIL-STD-883F, Method 2002
Mechanical Vibration	MIL-STD-883F, Method 2007
Temperature Cycle	JESD22, Method A104
Solderability	MIL-STD-883F, Method 2003
Moisture Sensitivity Level	MSL1 @ 260°C

Absolute Maximum Ratings

Maximum Ratings				
Parameter	Min.	Max.	Unit	
Storage Temperature	-65	150	°C	
VDD	-0.5	4	V	
Electrostatic Discharge	–	2000	V	
Soldering Temperature (follow standard Pb free soldering guidelines)	–	260	°C	

Thermal Data

Thermal Considerations			
Package	θJA, 4 Layer Board (°C/W)	θJA, 2 Layer Board (°C/W)	θJC, Bottom (°C/W)
7050	191	263	30
5032	97	199	24
3225	109	212	27
2520	117	222	26
2016	124	227	26

Ordering Information

MO - 9000A E - 7 F - E E - 25M000000

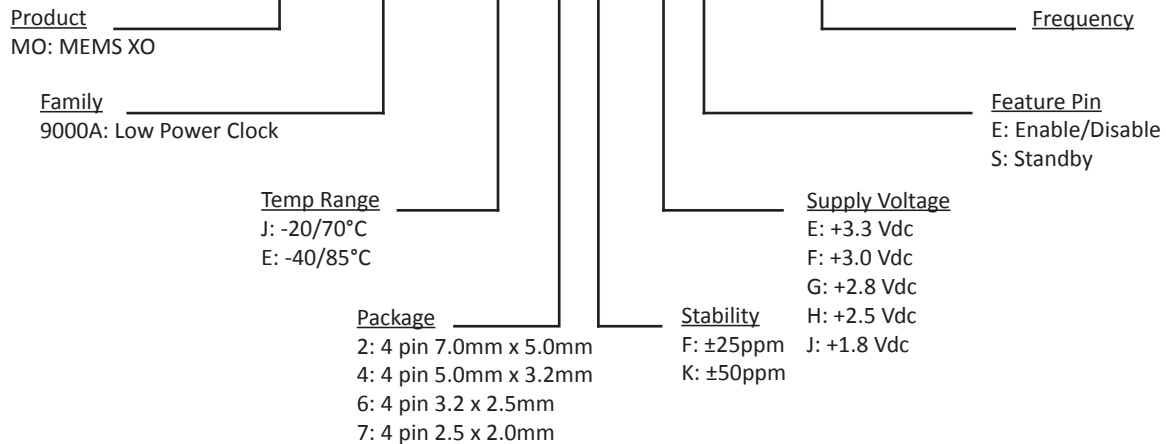

Notes:

1. Not all options and codes are available at all frequencies.
2. Unless otherwise stated all values are valid after warm-up time and refer to typical conditions for supply voltage, frequency control voltage, load, temperature (25°C).
3. Subject to technical modification.
4. Contact factory for availability.

For Additional Information, Please Contact

USA:

Vectron International
267 Lowell Road
Hudson, NH 03051
Tel: 1.888.328.7661
Fax: 1.888.329.8328

Europe:

Vectron International
Landstrasse, D-74924
Neckarbischofsheim, Germany
Tel: +49 (0) 7268.801.100
Fax: +49 (0) 7268.801.282

Asia:

Vectron International
1589 Century Avenue, the 19th Floor
Chamtime International Financial Center
Shanghai, China
Tel: 86.21.6081.2888
Fax: 86.21.6163.3598

Disclaimer

Vectron International reserves the right to make changes to the product(s) and or information contained herein without notice. No liability is assumed as a result of their use or application. No rights under any patent accompany the sale of any such product(s) or information.