

SCAN18540T Inverting Line Driver with TRI-STATE® Outputs

General Description

The SCAN18540T is a high speed, low-power line driver featuring separate data inputs organized into dual 9-bit bytes with byte-oriented paired output enable control signals. This device is compliant with IEEE 1149.1 Standard Test Access Port and Boundary Scan Architecture with the incorporation of the defined boundary-scan test logic and test access port consisting of Test Data Input (TDI), Test Data Out (TDO), Test Mode Select (TMS), and Test Clock (TCK).

Features

- IEEE 1149.1 (JTAG) compliant
- Dual output enable signals per byte
- TRI-STATE outputs for bus-oriented applications
- 9-bit data busses for parity applications
- Reduced-swing outputs source 24 mA/sink 48 mA (Mil)
- Guaranteed to drive 50Ω transmission line to TTL input levels of 0.8V and 2.0V
- TTL compatible inputs
- 25 mil pitch Cerpack packaging
- Includes CLAMP and HIGHZ instructions
- Standard Microcircuit Drawing (SMD) 5962-9312701

Connection Diagram

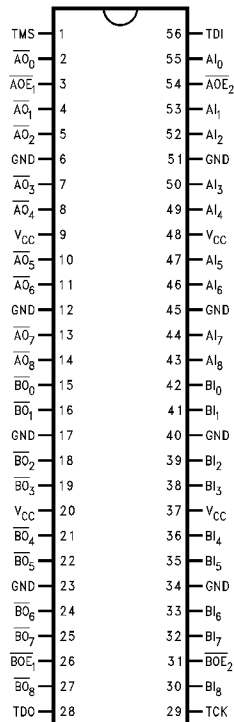

DS100323-1

Pin Names	Description
$\overline{AOE}_1, \overline{AOE}_2$	TRI-STATE Output Enable Input pins, A side
$\overline{BOE}_1, \overline{BOE}_2$	TRI-STATE Output Enable Input pins, B side
$\overline{AO}_{(0-8)}$	Output pins, A side
$\overline{BO}_{(0-8)}$	Output pins, B side

Pin Names	Description
$A_{(0-8)}$	Input pins, A side
$B_{(0-8)}$	Input pins, B side

TRI-STATE® is a registered trademark of National Semiconductor Corporation.

Truth Tables

Inputs			$\overline{AO} (0-8)$
\overline{AOE}_1	\overline{AOE}_2	AI (0-8)	
L	L	H	L
H	X	X	Z
X	H	X	Z
L	L	L	H

Inputs			$\overline{BO} (0-8)$
\overline{BOE}_1	\overline{BOE}_2	BI (0-8)	
L	L	H	L
H	X	X	Z
X	H	X	Z
L	L	L	H

H= HIGH Voltage Level
X= Immaterial
L = LOW Voltage Level
Z = High Impedance

Block Diagrams

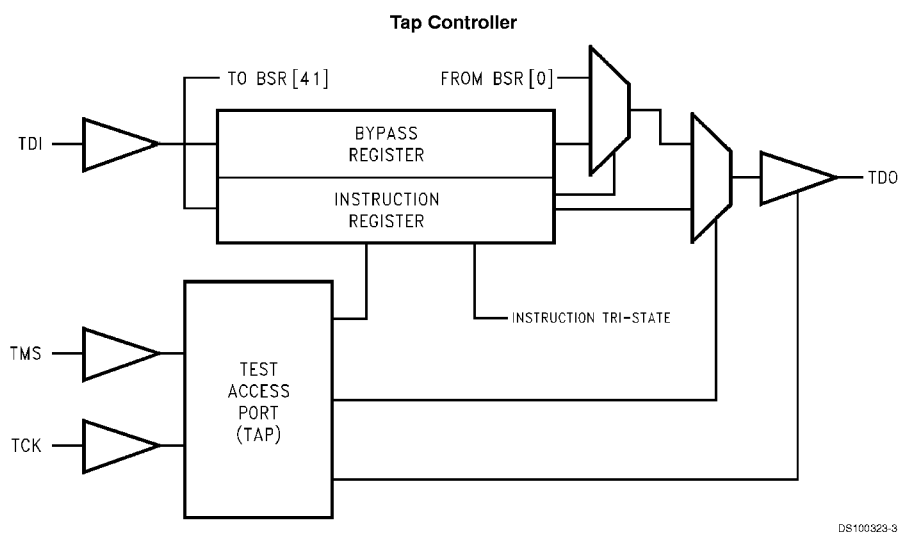
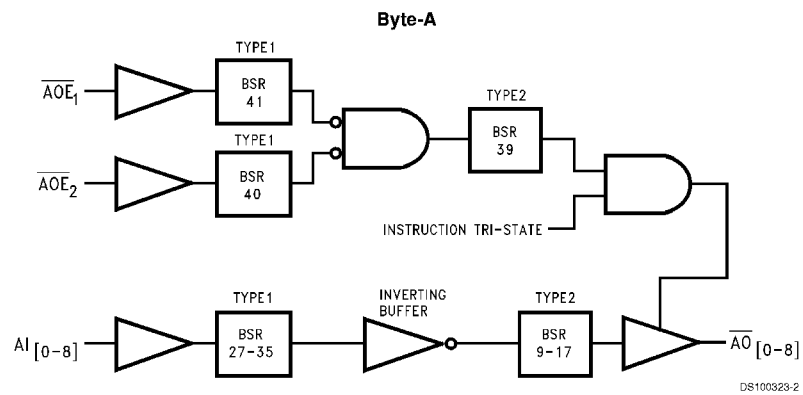

Block Diagrams (Continued)

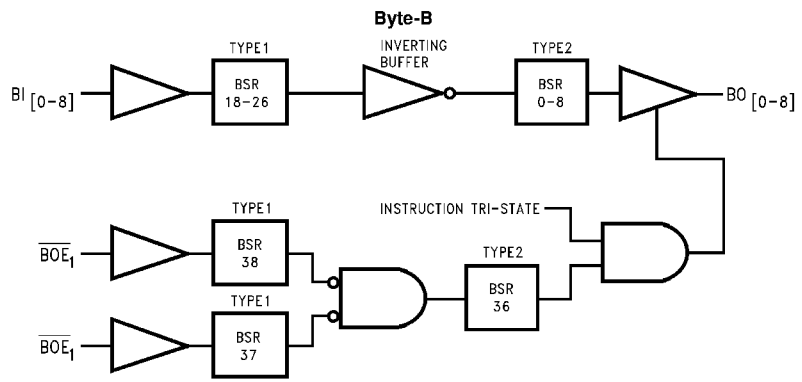

Note: BSR stands for Boundary Scan Register

DS100323-4

Description of BOUNDARY-SCAN Circuitry

The scan cells used in the BOUNDARY-SCAN register are one of the following two types depending upon their location. Scan cell TYPE1 is intended to solely observe system data, while TYPE2 has the additional ability to control system data. (See IEEE Standard 1149.1 *Figure 10–11* for a further description of scan cell TYPE1 and *Figure 10–12* for a further description of scan cell TYPE2.)

Scan cell TYPE1 is located on each system input pin while scan cell TYPE2 is located at each system output pin as well as at each of the two internal active-high output enable signals. AOE controls the activity of the A-outputs while BOE controls the activity of the B-outputs. Each will activate their respective outputs by loading a logic high.

The BYPASS register is a single bit shift register stage identical to scan cell TYPE1. It captures a fixed logic low.

Bypass Register Scan Chain Definition Logic 0

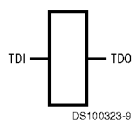

The INSTRUCTION register is an 8-bit register which captures the default value of 01001101. The two least significant bits of this captured value (01) are required by IEEE Std 1149.1. The upper six bits are unique to the SCAN18540T device. SCAN CMOS Test Access Logic devices do not in-

clude the IEEE 1149.1 optional identification register. Therefore, this unique captured value can be used as a "pseudo ID" code to confirm that the correct device is placed in the appropriate location in the boundary scan chain.

Instruction Register Scan Chain Definition

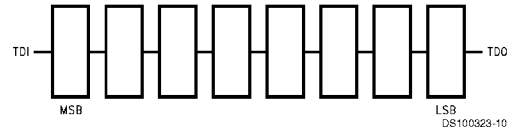

MSB→LSB

Instruction Code	Instruction
00000000	EXTEST
10000001	SAMPLE/PRELOAD
10000010	CLAMP
00000011	HIGH-Z
All Others	BYPASS

Description of BOUNDARY-SCAN Circuitry (Continued)

Scan Cell TYPE1

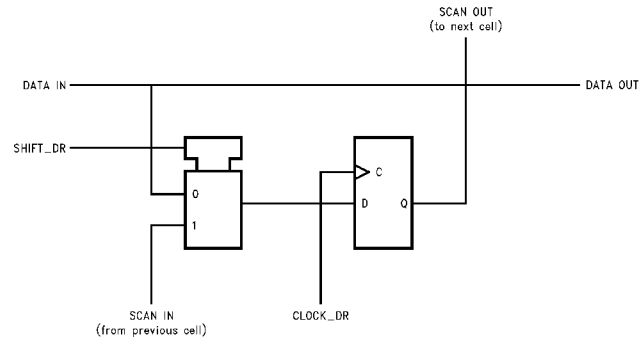

Scan Cell TYPE2

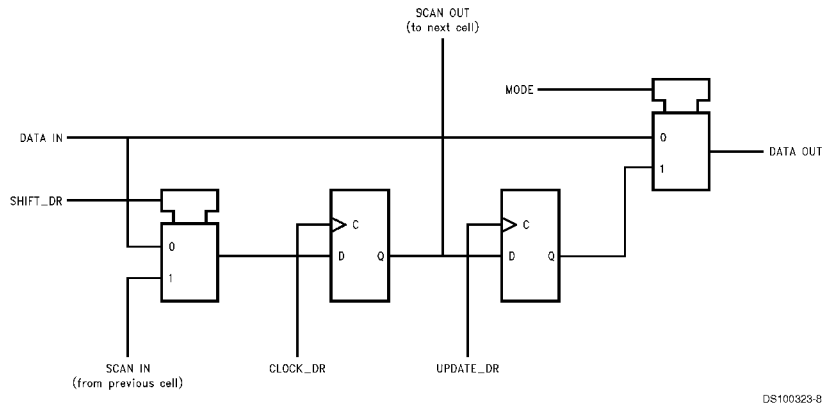

Description of BOUNDARY-SCAN Circuitry (Continued)

BOUNDARY-SCAN Register Scan Chain Definition (42 Bits in Length)

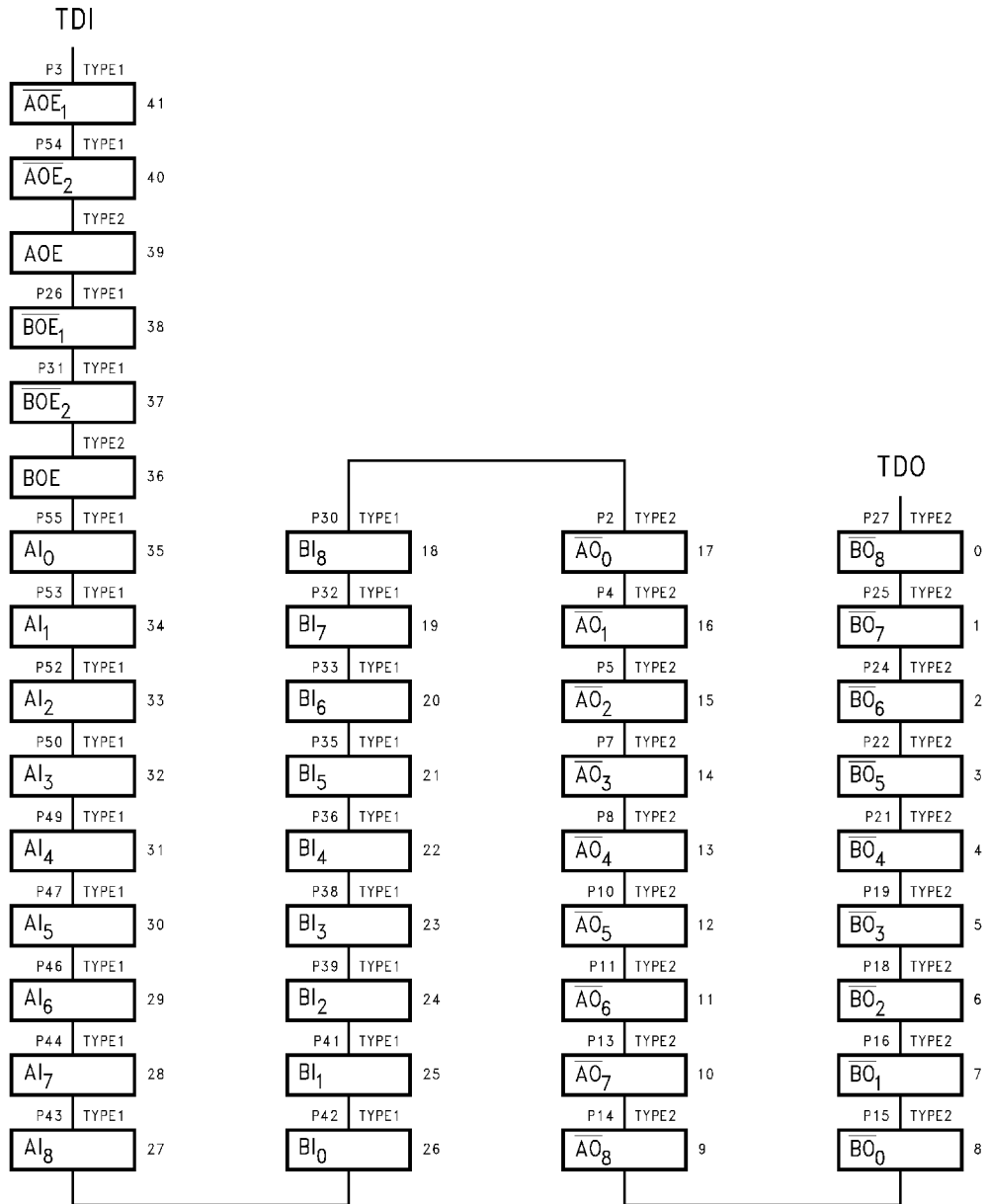

Description of BOUNDARY-SCAN Circuitry (Continued)

BOUNDARY-SCAN Register Definition Index

Bit No.	Pin Name	Pin No.	Pin Type	Scan Cell Type	
41	$\overline{AOE_1}$	3	Input	TYPE1	Control Signals
40	$\overline{AOE_2}$	54	Input	TYPE1	
39	\overline{AOE}		Internal	TYPE2	
38	$\overline{BOE_1}$	26	Input	TYPE1	
37	$\overline{BOE_2}$	31	Input	TYPE1	
36	\overline{BOE}		Internal	TYPE2	
35	AI_0	55	Input	TYPE1	
34	AI_1	53	Input	TYPE1	
33	AI_2	52	Input	TYPE1	
32	AI_3	50	Input	TYPE1	
31	AI_4	49	Input	TYPE1	
30	AI_5	47	Input	TYPE1	
29	AI_6	46	Input	TYPE1	
28	AI_7	44	Input	TYPE1	
27	AI_8	43	Input	TYPE1	
26	BI_0	42	Input	TYPE1	B-in
25	BI_1	41	Input	TYPE1	
24	BI_2	39	Input	TYPE1	
23	BI_3	38	Input	TYPE1	
22	BI_4	36	Input	TYPE1	
21	BI_5	35	Input	TYPE1	
20	BI_6	33	Input	TYPE1	
19	BI_7	32	Input	TYPE1	
18	BI_8	30	Input	TYPE1	
17	AO_0	2	Output	TYPE2	A-out
16	AO_1	4	Output	TYPE2	
15	AO_2	5	Output	TYPE2	
14	AO_3	7	Output	TYPE2	
13	AO_4	8	Output	TYPE2	
12	AO_5	10	Output	TYPE2	
11	AO_6	11	Output	TYPE2	
10	AO_7	13	Output	TYPE2	
9	AO_8	14	Output	TYPE2	
8	BO_0	15	Output	TYPE2	B-in
7	BO_1	16	Output	TYPE2	
6	BO_2	18	Output	TYPE2	
5	BO_3	19	Output	TYPE2	
4	BO_4	21	Output	TYPE2	
3	BO_5	22	Output	TYPE2	
2	BO_6	24	Output	TYPE2	
1	BO_7	25	Output	TYPE2	
0	BO_8	27	Output	TYPE2	

Absolute Maximum Ratings (Note 1)

If Military/Aerospace specified devices are required, please contact the National Semiconductor Sales Office/Distributors for availability and specifications.

Supply Voltage (V_{CC})	-0.5V to +7.0V
DC Input Diode Current (I_{IK})	
$V_I = -0.5V$	-20 mA
$V_I = V_{CC} + 0.5V$	+20 mA
DC Output Diode Current (I_{OK})	
$V_O = -0.5V$	-20 mA
$V_O = V_{CC} + 0.5V$	+20 mA
DC Output Voltage (V_O)	-0.5V to $V_{CC} + 0.5V$
DC Output Source/Sink Current (I_O)	± 70 mA
DC V_{CC} or Ground Current	
Per Output Pin	± 70 mA
Junction Temperature	
Cerpack	+175°C
Storage Temperature	-65°C to +150°C

ESD (Min)

2000V

Recommended Operating Conditions

Supply Voltage (V_{CC})	
SCAN Products	4.5V to 5.5V
Input Voltage (V_I)	0V to V_{CC}
Output Voltage (V_O)	0V to V_{CC}
Operating Temperature (T_A)	
Military	-55°C to +125°C
Minimum Input Edge Rate dV/dt	125 mV/ns
V_{IN} from 0.8V to 2.0V	
V_{CC} @ 4.5V, 5.5V	

Note 1: Absolute maximum ratings are those values beyond which damage to the device may occur. The databook specifications should be met, without exception, to ensure that the system design is reliable over its power supply, temperature, and output/input loading variables. National does not recommend operation of SCAN circuits outside databook specifications.

DC Electrical Characteristics

Symbol	Parameter	V_{CC} (V)	Military	Units	Conditions
			$T_A = -55^\circ\text{C to } +125^\circ\text{C}$		
			Guaranteed Limits		
V_{IH}	Minimum High Input Voltage	4.5	2.0	V	$V_{OUT} = 0.1V$ or $V_{CC} - 0.1V$
		5.5	2.0		
V_{IL}	Maximum Low Input Voltage	4.5	0.8	V	$V_{OUT} = 0.1V$ or $V_{CC} - 0.1V$
		5.5	0.8		
V_{OH}	Minimum High Output Voltage	4.5	3.15	V	$I_{OUT} = -50 \mu A$
		5.5	4.15		
		4.5	2.4	V	$V_{IN} = V_{IL}$ or V_{IH} $I_{OH} = -24 \text{ mA}$
		5.5	2.4		
V_{OL}	Maximum Low Output Voltage	4.5	0.1	V	$I_{OUT} = 50 \mu A$
		5.5	0.1		
		4.5	0.55		$V_{IN} = V_{IL}$ or V_{IH} $I_{OL} = 48 \text{ mA}$
		5.5	0.55		
I_{IN}	Maximum Input Leakage Current	5.5	± 1.0	μA	$V_I = V_{CC}, \text{ GND}$
I_{IN} TDI, TMS	Maximum Input Leakage	5.5	3.7	μA	$V_I = V_{CC}$
			-385	μA	$V_I = \text{GND}$
			-160	μA	$V_I = \text{GND}$
I_{OLD}	Minimum Dynamic Output Current (Note 2)	5.5	63	mA	$V_{OLD} = 0.8V \text{ Max}$
I_{OHD}			-27	mA	$V_{OHD} = 2.0V \text{ Min}$
I_{OZ}	Maximum Output Leakage Current	5.5	± 10.0	μA	$V_I (\text{OE}) = V_{IL}, V_{IH}$
I_{OS}	Output Short Circuit Current	5.5	-100	mA Min	$V_O = 0V$
I_{CC}	Maximum Quiescent Supply Current	5.5	168	μA	$V_O = \text{Open}$ TDI, TMS = V_{CC}
		5.5	930	μA	$V_O = \text{Open}$ TDI, TMS = GND

DC Electrical Characteristics (Continued)

Symbol	Parameter	V _{CC} (V)	Military		Units	Conditions
			T _A = -55°C to +125°C			
			Guaranteed Limits			
I _{CC1}	Maximum I _{CC} Per Input	5.5	2.0		mA	V _I = V _{CC} -2.1V
		5.5	2.15		mA	V _I = V _{CC} -2.1V TDI/TMS Pin, Test One with the other Floating

Note 2: Maximum test duration 2.0 ms, one output loaded at a time.

Note 3: All outputs loaded; thresholds associated with output under test.

Noise Specifications

Symbol	Parameter	V _{CC} (V)	Military		Units
			T _A = -55°C to +125°C		
			Guaranteed Limits		
V _{OLP}	Maximum High Output Noise (Notes 4, 5)	5.0	0.8		V
V _{OLV}	Minimum Low Output Noise (Notes 4, 5)	5.0	-0.8		V

Note 4: Maximum number of outputs that can switch simultaneously is n. (n-1) outputs are switched LOW and one output held LOW.

Note 5: Maximum number of outputs that can switch simultaneously is n. (n-1) outputs are switched HIGH and one output held HIGH.

AC Electrical Characteristics

Normal Operation

Symbol	Parameter	V _{CC} (V) (Note 7)	Military		Units
			T _A = -55°C to +125°C		
			C _L = 50 pF		
			Min	Max	
t _{PLH}	Propagation Delay	5.0	2.5	10.5	ns
t _{PHL}	Data to Q		2.5	11.0	
t _{PLZ}	Disable Time	5.0	1.5	11.2	ns
t _{PHZ}			1.5	11.2	
t _{PZL}	Enable Time	5.0	2.0	14.0	ns
t _{PZH}			2.0	12.0	

AC Electrical Characteristics

Scan Test Operation

Symbol	Parameter	V _{CC} (V) (Note 7)	Military		Units
			T _A = -55°C to +125°C		
			C _L = 50 pF		
			Min	Max	
t _{PLH}	Propagation Delay	5.0	3.5	15.8	ns
t _{PHL}	TCK to TDO		3.5	15.8	
t _{PLZ}	Disable Time	5.0	2.5	12.8	ns
t _{PHZ}	TCK to TDO		2.5	12.8	

AC Electrical Characteristics (Continued)

Scan Test Operation

Symbol	Parameter	V _{CC} (V) (Note 7)	Military		Units
			T _A = -55° C to +125° C C _L = 50 pF		
			Min	Max	
t _{PZL} , t _{PZH}	Enable Time TCK to TDO	5.0	3.0 3.0	16.7 16.7	ns
t _{PLH} , t _{PHL}	Propagation Delay TCK to Data Out During Update- -DR State	5.0	5.0 5.0	21.7 21.7	ns
t _{PLH} , t _{PHL}	Propagation Delay TCK to Data Out During Update- IR State	5.0	5.0 5.0	21.2 21.2	ns
t _{PLH} , t _{PHL}	Propagation Delay TCK to Data Out During Test Logic Reset State	5.0	5.5 5.5	23.0 23.0	ns
t _{PLZ} , t _{PHZ}	Propagation Delay TCK to Data Out During Update- DR State	5.0	4.0 4.0	19.6 19.6	ns
t _{PLZ} , t _{PHZ}	Propagation Delay TCK to Data Out During Update- IR State	5.0	5.0 5.0	22.4 22.4	ns
t _{PLZ} , t _{PHZ}	Propagation Delay TCK to Data Out During Test Logic Reset State	5.0	5.0 5.0	23.3 23.3	ns
t _{PZL} , t _{PZH}	Propagation Delay TCK to Data Out During Update- DR State	5.0	5.0 5.0	22.6 22.6	ns
t _{PZL} , t _{PZH}	Propagation Delay TCK to Data Out During Update- IR State	5.0	6.5 6.5	26.2 26.2	ns
t _{PZL} , t _{PZH}	Propagation Delay TCK to Data Out During Test Logic Reset State	5.0	7.0 7.0	27.4 27.4	ns

Note 6: All Propagation Delays involving TCK are measured from the falling edge of TCK.

AC Operating Requirements

Scan Test Operation

Symbol	Parameter	V _{CC} (V) (Note 7)	Military	Units
			T _A = -55°C to +125°C C _L = 50 pF	
			Guaranteed Minimum	
t _S	Setup Time, H or L Data to TCK (Note 8)	5.0	3.0	ns
t _H	Hold Time, H or L TCK to Data (Note 8)	5.0	5.5	ns
t _S	Setup Time, H or L \overline{AOE}_n , \overline{BOE}_n to TCK (Note 10)	5.0	3.0	ns
t _H	Hold Time, H or L TCK to \overline{AOE}_n , \overline{BOE}_n (Note 10)	5.0	4.5	ns
t _S	Setup Time, H or L Internal AOE, BOE, to TCK (Note 9)	5.0	3.0	ns
t _H	Hold Time, H or L TCK to Internal AOE, BOE (Note 9)	5.0	3.0	ns
t _S	Setup Time, H or L TMS to TCK	5.0	8.0	ns
t _H	Hold Time, H or L TCK to TMS	5.0	2.0	ns
t _S	Setup Time, H or L TDI to TCK	5.0	4.0	ns
t _H	Hold Time, H or L TCK to TDI	5.0	4.5	ns
t _W	Pulse Width TCK H L	5.0	12.0 5.0	ns
f _{max}	Maximum TCK Clock Frequency	5.0	25	MHz
T _{PU}	Wait Time, Power Up to TCK	5.0	100	ns
T _{DN}	Power Down Delay	0.0	100	ms

Note 7: Voltage Range 5.0 is 5.0V ±0.5V.

All Input Timing Delays involving TCK are measured from the rising edge of TCK.

Note 8: This delay represents the timing relationship between the data input and TCK at the associated scan cells numbered 0-8, 9-17, 18-26, and 27-35.

Note 9: This delay represents the timing relationship between AOE/BOE and TCK for scan cells 36 and 39 only.

Note 10: Timing pertains to BSR 37, 38, 40 and 41.

Capacitance

Symbol	Parameter	Typ	Units	Conditions
C_{IN}	Input Pin Capacitance	4.0	pF	$V_{CC} = 5.0V$
C_{OUT}	Output Pin Capacitance	13.0	pF	$V_{CC} = 5.0V$
C_{PD}	Power Dissipation Capacitance	34.0	pF	$V_{CC} = 5.0V$

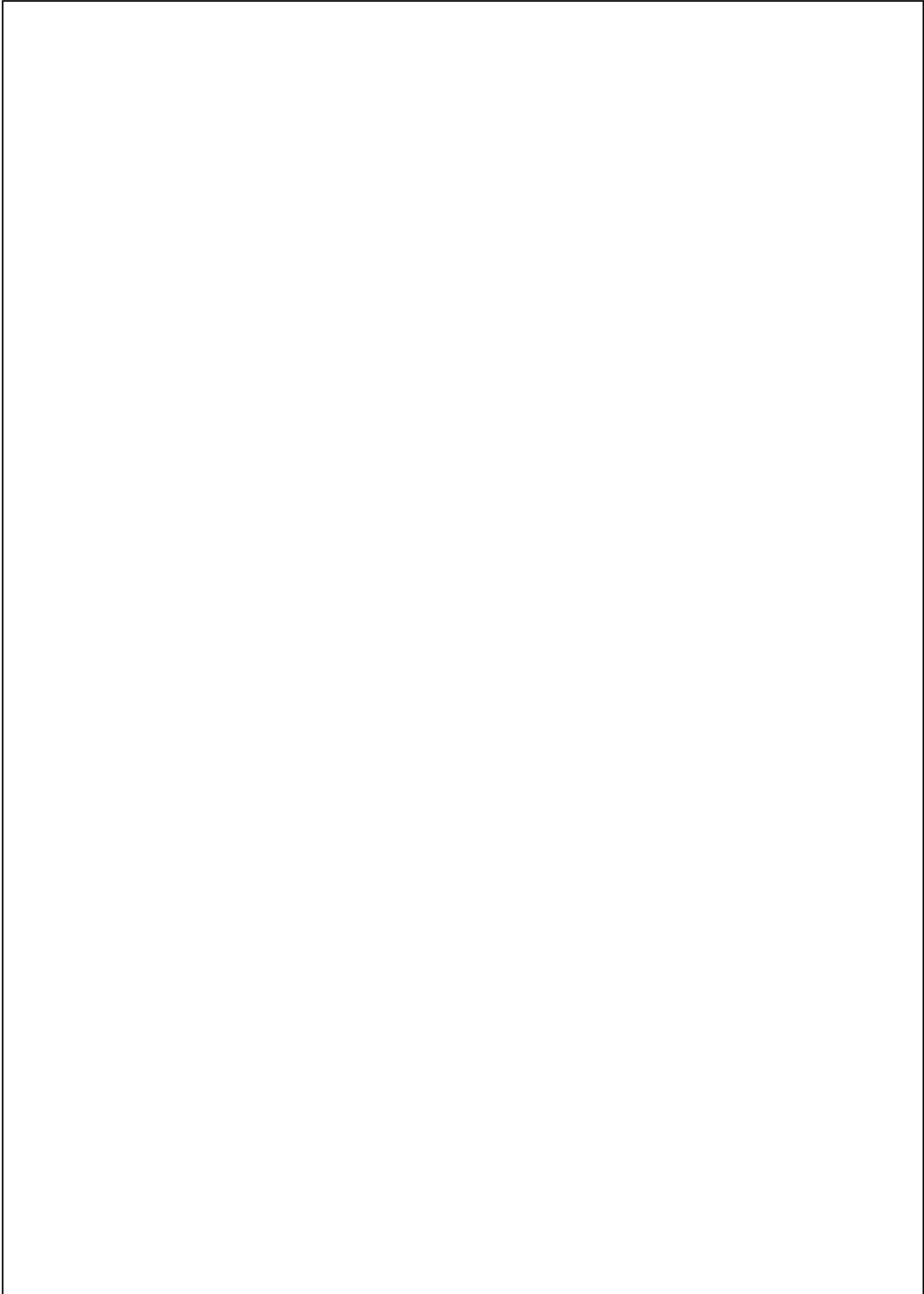

Physical Dimensions inches (millimeters) unless otherwise noted

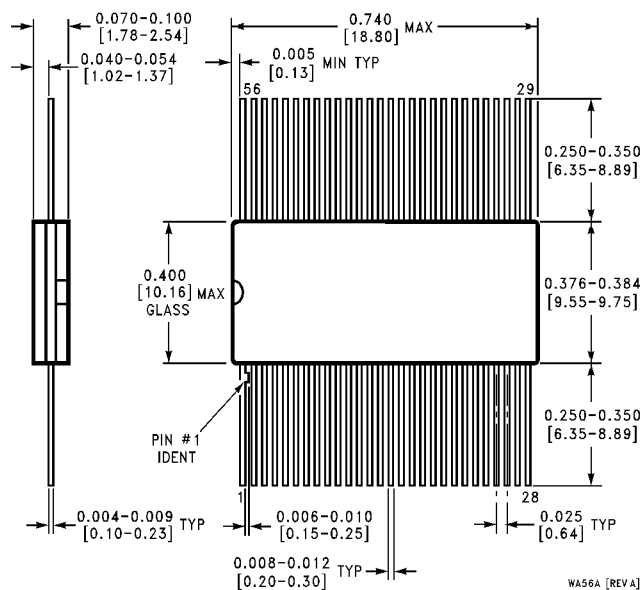

**56-Lead Ceramic Flatpak (F)
 NS Package Number WA56A**

LIFE SUPPORT POLICY

NATIONAL'S PRODUCTS ARE NOT AUTHORIZED FOR USE AS CRITICAL COMPONENTS IN LIFE SUPPORT DEVICES OR SYSTEMS WITHOUT THE EXPRESS WRITTEN APPROVAL OF THE PRESIDENT OF NATIONAL SEMICONDUCTOR CORPORATION. As used herein:

1. Life support devices or systems are devices or systems which, (a) are intended for surgical implant into the body, or (b) support or sustain life, and whose failure to perform when properly used in accordance with instructions for use provided in the labeling, can be reasonably expected to result in a significant injury to the user.
2. A critical component in any component of a life support device or system whose failure to perform can be reasonably expected to cause the failure of the life support device or system, or to affect its safety or effectiveness.



National Semiconductor Corporation
 Americas
 Tel: 1-800-272-9959
 Fax: 1-800-737-7018
 Email: support@nsc.com

National Semiconductor Europe
 Fax: +49 (0) 1 80-530 85 86
 Email: europe.support@nsc.com
 Deutsch Tel: +49 (0) 1 80-530 85 85
 English Tel: +49 (0) 1 80-532 78 32
 Français Tel: +49 (0) 1 80-532 93 58
 Italiano Tel: +49 (0) 1 80-534 16 80

National Semiconductor Asia Pacific Customer Response Group
 Tel: 65-2544466
 Fax: 65-2504466
 Email: sea.support@nsc.com

National Semiconductor Japan Ltd.
 Tel: 81-3-5620-6175
 Fax: 81-3-5620-6179

www.national.com