

FEATURES

- 8-, 10-, 12-Bit resolution
- Settling times to 25 nanoseconds
- 20 ppm/°C tempco
- Unipolar or bipolar operation
- Current output
- Internal feedback resistor

GENERAL DESCRIPTION

The DAC-HF Series of hybrid DAC's are ultra high-speed, current output devices. They incorporate state-of-the-art performance in a miniature package, achieving maximum output settling times of 25 nanoseconds for the 8- and 10-bit models and 50 nanoseconds for the 12-bit model. They can be used to drive a resistor load directly for up to $\pm 1V$ output or a fast operational amplifier (such as DATEL's AM-500) for higher voltage outputs with sub-microsecond settling times. A tapped feedback resistor and a bipolar offset resistor are included internally to give five programmable output voltage ranges with an external operational amplifier.

The DAC-HF design combines proven hybrid production techniques with advanced circuit design to realize high speed current switching. The design incorporates fast PNP current switches driving a low impedance R-2R thin-film ladder network. The nichrome thin-film resistor network is deposited by electron beam evaporation on a low capacitance substrate to assure high-speed performance. The resistors are then functionally trimmed by laser for optimum linearity.

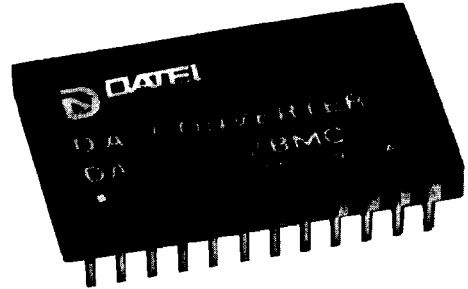

MECHANICAL DIMENSIONS

INCHES (MM)

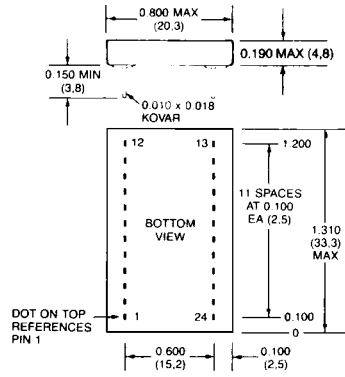

NOTE: PINS HAVE 0.025 INCH STANDOFF FROM CASE. ± 0.01 "

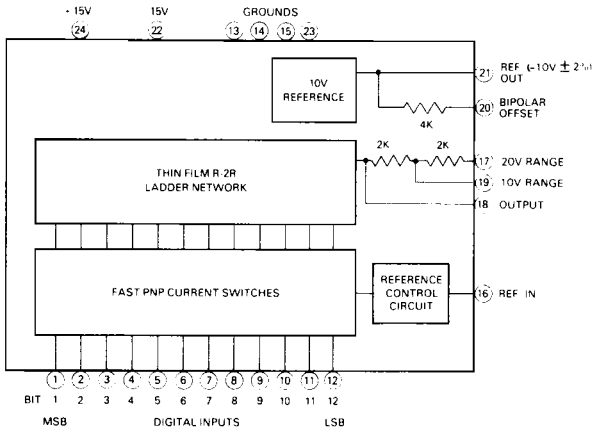

NOTE: FOR DAC HF10B PINS 11 & 12 ARE NO CONNECTION
FOR DAC HF8B PINS 9, 10, 11 & 12 ARE NO CONNECTION

INPUT/OUTPUT CONNECTIONS

PIN	FUNCTION	PIN	FUNCTION
1	BIT 1 IN (MSB)	13	GROUND
2	BIT 2 IN	14	GROUND
3	BIT 3 IN	15	GROUND
4	BIT 4 IN	16	REF IN
5	BIT 5 IN	17	20 V RANGE
6	BIT 6 IN	18	OUTPUT
7	BIT 7 IN	19	10 V RANGE
8	BIT 8 IN	20	BIPOLAR OFFSET
9	BIT 9 IN	21	REF OUT
10	BIT 10 IN	22	-15 VDC
11	BIT 11 IN	23	GROUND
12	BIT 12 IN (LSB)	24	+15 VDC

ABSOLUTE MAXIMUM RATINGS, ALL MODELS

Positive Supply, Pin 24	+18V
Negative Supply, Pin 22	-18V
Digital Input Voltage, Pins 1 to 12	+15V

FUNCTIONAL SPECIFICATIONS

Typical at 25°C, ±15V supplies unless otherwise specified.

DESCRIPTION	8B	10B	12B
INPUTS			
Resolution, Bits	8	10	12
Coding, Unipolar Output	Straight Binary		
Coding, Bipolar Output	Offset Binary		
Input Logic Level, Bit ON ("1")	±2.0 to +5.5V at +40μA		
Input Logic Level, Bit OFF ("0")	0V to +0.8V at 2.6 mA		
OUTPUTS			
Output Current Range, Unipolar	0 to +5 mA		
Output Current Range, Bipolar	±2.5 mA		
Output Voltage Compliance	±1.2V		
Output Voltage Ranges ²	0 to -5V 0 to -10V ±2.5V ±5V ±10V		
Output Resistance	400 ohms ±20%		
Output Capacitance	15 pF		
Output Leakage Current, All Bits OFF	15 nA		
PERFORMANCE			
Linearity Error, max	0.012%		
T _{MIN} to T _{MAX}	0.024%		
Differential Linearity Error, Max	0.012%		
T _{MIN} to T _{MAX}	0.024%		
Monotonicity	Guaranteed over oper. temp. range		
Gain Tempco, max.	±20 ppm/°C		
Offset Tempco, Bipolar, max.	±10 ppm/°C of F.S.R. ³		
Zero Tempco, max.	±1.5 ppm/°C of F.S.R. ³		
Settling Time, nsec. max. ¹	25	25	50
Power Supply Sensitivity	0.01%/‰ Supply		
POWER REQUIREMENTS			
Supply Voltage	±15V dc ±0.5V		
Positive Quiescent Current, max.	35mA	40mA	45mA
Negative Quiescent Current, max.	15mA	15mA	15mA
PHYSICAL/ENVIRONMENTAL			
Operating Temperature Range	0°C to +70°C (BMC)		
Storage Temperature Range	-55°C to +125°C (BMM, 883B)		
Package Type	24-Pin Ceramic DIP		
Pins	0.010 × 0.018 inch Kovar		
Weight	0.2 oz (6g.)		
FOOTNOTES:			
1. Full scale current change to 1 LSB with 400Ω load.			
2. With External Operational Amplifier.			
3. F.S.R. is Full Scale Range, or the difference between minimum and maximum output values.			

TECHNICAL NOTES

- Proper operation of the DAC-HF series converters is dependent on good board layout and connection practices. Bypass supplies as shown in the connection diagrams. Mount bypass capacitors close to the converter, directly to the supply pins where possible.
- Use of a ground plane is particularly important in high speed D to A converters as it reduces high frequency noise and aids in decoupling the digital inputs from the analog output. Avoid ground loop problems by connecting all grounds on the board to the ground plane. The remainder of the ground plane should include as much of the circuit board as possible.
- When the converter is configured for voltage output with an external operational amplifier, keep the leads from the converter to the output amplifier as short as possible.
- The high speed current switching technique used in the DAC-HF series inherently reduces the amplitude and duration of large transient spikes at the output ("glitches"). The most severe glitches occur at half-scale, the major carry transition from 011 ... 1 to 100 ... 0 or vice versa. At this time, a skewing of the input codes can create a transition state code of 111 ... 1. The duration of the "transition state code" is dependent on the degree of skewing but its effect is dependent on the speed of the DAC (an ultra-fast DAC will respond to these brief spurious inputs to a greater degree than a slow DAC). Minimize the effects of input skewing by using a high-speed input register to match input switching times. The input register recommended for use with the DAC-HF is easily implemented with two Texas Instruments SN74S174 hex D-type flip-flops. This register will reduce glitches to a very low level and ensure fast output settling times.
- Test the DAC-HF using a low capacitance test probe (such as a 10X probe). Take care to assure the shortest possible connection between probe ground and circuit ground. Long probe ground leads may pick up environmental E.M.I. causing artifacts on the scope display, i.e., signals that do not originate at the unit under test.
- Passive components used with the DAC-HF may be as indicated here: 0.1 μF and 1 μF bypass capacitors should be ceramic type and tantalum type respectively; the 400Ω output load is a 0.1% 10 ppm/°C metal film type; adjustment potentiometers are cermet types; other resistors may be ±10% carbon composition types.
- Output voltage compliance is ±1.2V to preserve the linearity of the converter. In the bipolar mode, the DAC-HF can be operated with no load to give an output voltage of ±1.0V. In the unipolar mode, the load resistance must be less than 600Ω to give less than +1.2V output. The specified output currents of 0 to +5 mA and ±2.5 mA are measured into a short circuit or an operational amplifier summing junction.

CONNECTION AND CALIBRATION

UNIPOLAR CURRENT OUTPUT CONNECTIONS

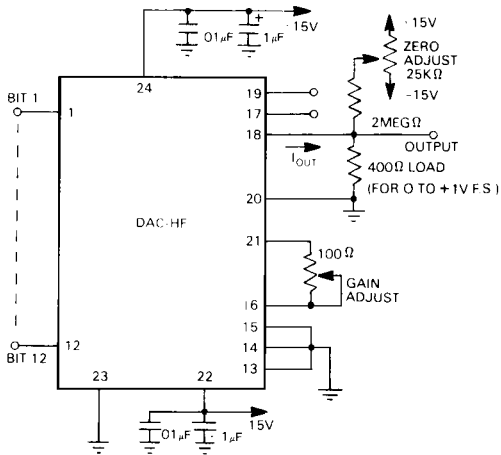

UNIPOLAR CURRENT OUTPUT CALIBRATION PROCEDURE

1. Connect the converter as shown in the connection diagram.
2. Set all inputs low and adjust the ZERO ADJUST potentiometer for a reading of 0V at the output.
3. Set all inputs high and adjust the GAIN ADJUST potentiometer for a reading of $-F.S. + 1\text{ LSB}$ (given in the coding table for 12-bit units).

BIPOLAR CURRENT OUTPUT CONNECTIONS

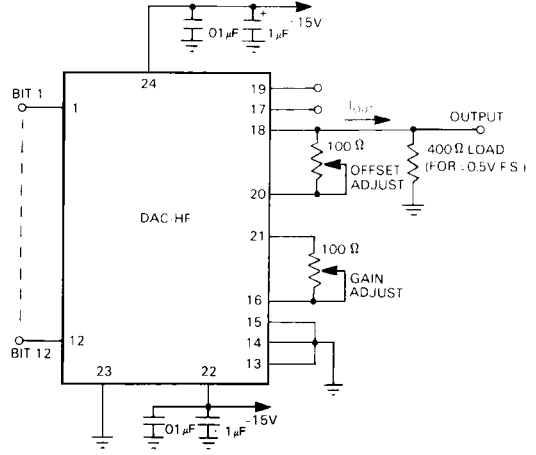

BIPOLAR CURRENT OUTPUT CALIBRATION PROCEDURE

1. Connect the converter as shown in the connection diagram.
2. Set all inputs low and adjust the OFFSET ADJUST potentiometer for an output reading of $+F.S.$, (given in the coding table for 12-bit units).
3. Set all inputs high and adjust the GAIN ADJUST potentiometer for an output reading of $-F.S. + 1\text{ LSB}$, (given in the coding table for 12-bit units).

CODING TABLES UNIPOLAR OUTPUT

UNIPOLAR SCALE	INPUT CODING STRAIGHT BINARY	ANALOG OUTPUT		
		0 to +1V F.S	0 to -5V F.S	0 to -10V F.S
-F.S. + 1LSB	1111 1111 1111	+ 0.9998V	- 4.9988V	- 9.9976V
-3/4 F.S.	1100 0000 0000	+ 0.7500V	- 3.7500V	- 7.5000V
-1/2 F.S.	1000 0000 0000	+ 0.5000V	- 2.5000V	- 5.0000V
-1/4 F.S.	0100 0000 0000	+ 0.2500V	- 1.2500V	- 2.5000V
-1 LSB	0000 0000 0001	+ 0.0002V	- 0.0012V	- 0.0024V
0	0000 0000 0000	+ 0.0000V	+ 0.0000V	0.0000V

BIPOLAR OUTPUT

BIPOLAR SCALE	INPUT CODING OFFSET BINARY	ANALOG OUTPUT			
		± 0.5V F.S.	± 2.5V F.S.	± 5V F.S.	± 10V F.S.
-F.S. + 1LSB	1111 1111 1111	+ 0.4998V	- 2.4988V	- 4.9976V	- 9.9951V
-1/2 F.S.	1100 0000 0000	+ 0.1250V	- 1.2500V	- 2.5000V	- 5.0000V
-1 LSB	1000 0000 0001	+ 0.0002V	- 0.0012V	- 0.0024V	- 0.0049V
0	1000 0000 0000	0.0000V	0.0000V	0.0000V	0.0000V
+1/2 F.S.	0100 0000 0000	- 0.1250V	+ 1.2500V	+ 2.500V	+ 5.0000V
+F.S. - 1LSB	0000 0000 0001	- 0.4998V	+ 2.4988V	+ 4.9976V	+ 9.9951V
+F.S.	0000 0000 0000	- 0.5000V	+ 2.5000V	+ 5.0000V	+ 10.0000V

PROGRAMMABLE OUTPUT RANGE PIN CONNECTIONS

OUTPUT VOLTAGE RANGE	FEEDBACK CONNECTION	CONNECT THESE PINS TOGETHER
0 to -5V	PIN 19	PIN 17 to PIN 18 PIN 20 to PIN 23
0 to -10V	PIN 19	PIN 20 to PIN 23
± 2.5V	PIN 19	PIN 17 to PIN 18 PIN 20 to PIN 18
± 5V	PIN 19	PIN 20 to PIN 18
± 10V	PIN 17	PIN 20 to PIN 18

In all programmable output ranges pin 18 connects to external operational amplifier inverting input

APPLICATIONS

UNIPOLAR ULTRA-FAST VOLTAGE OUTPUT

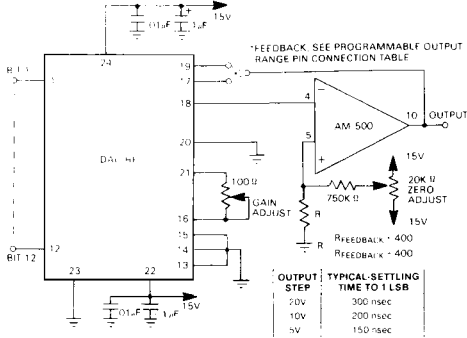

UNIPOLAR FAST VOLTAGE OUTPUT CIRCUIT

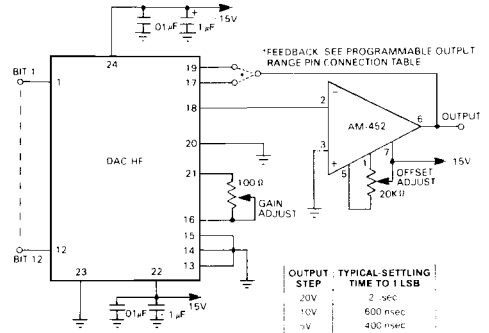

VOLTAGE OUTPUT WAVEFORMS

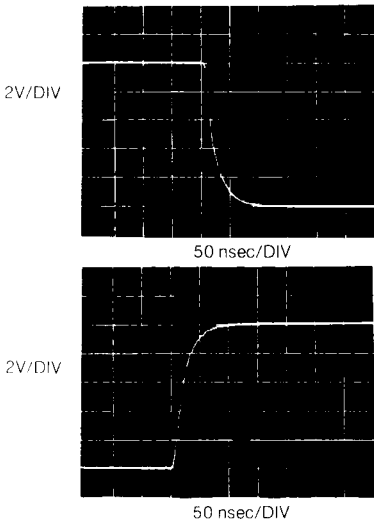

DAC-HF with AM-500 ±5V output full scale (10V) step

EQUIVALENT OUTPUT CIRCUIT

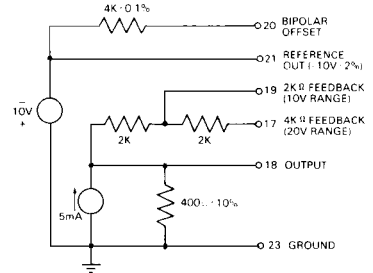

HIGH SPEED INPUT REGISTER

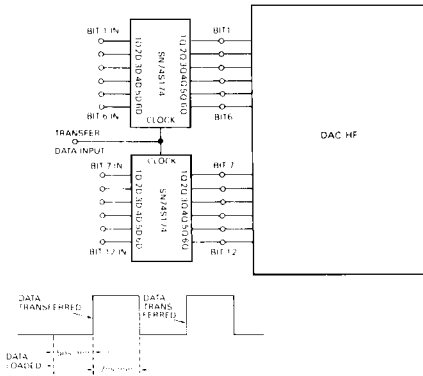

ORDERING INFORMATION

MODEL	OPERATING TEMP. RANGE	SEAL
DAC-HF8BMC	0 to +70 °C	Hermetic
DAC-HF8BMM	-55 to +125 °C	Hermetic
DAC-HF8/883B	-55 to +125 °C	Hermetic
DAC-HF10BMC	0 to +70 °C	Hermetic
DAC-HF10BMM	-55 to +125 °C	Hermetic
DAC-HF10/883B	-55 to +125 °C	Hermetic
DAC-HF12BMC	0 to +70 °C	Hermetic
DAC-HF12BMM	-55 to +125 °C	Hermetic
DAC-HF12/883B	-55 to +125 °C	Hermetic