

SD-14620 Series Data Sheet

TWO-CHANNEL SYNCHRO/RESOLVER-TO-DIGITAL (S/R-D) CONVERTERS

Make sure the next Card you purchase has...

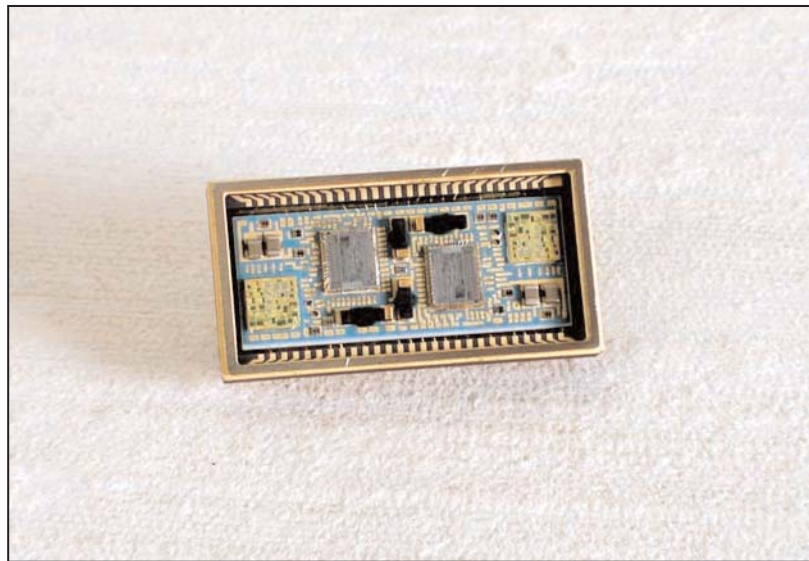
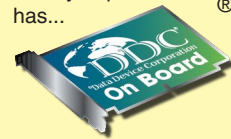

DESCRIPTION

The SD-14620 Series converters are small, low-cost, two-channel hybrid Synchro- or Resolver-to-Digital converters based on a single-chip monolithic. The SD-14620X“S” option offers synthesized reference circuitry to correct for phase shifts between the reference and signal inputs. The two channels are independent but share the digital output and +5 VDC power pins. The package is 54-pin ceramic, yet is the size of a 28-pin DDIP.

Resolution programming allows selection of 10-, 12-, 14- or 16-bit modes. This feature allows selection of either low-resolution for fast tracking or higher resolution for higher accuracy.

The velocity outputs (VEL A, VEL B) of the SD-14620 Series, which can be used to replace a tachometer, are ± 4 V signals referenced to analog ground. The SD-14620 Series also offers Built-In-Test outputs for each channel ($\overline{\text{BIT}}\text{-A}$, $\overline{\text{BIT}}\text{-B}$). The converters are available with operating temperature ranges of 0°C to +70°C, -40°C to +85°C and -55°C to +125°C. MIL-PRF-38534 processing is available.

APPLICATIONS

With its low-cost, small size, high accuracy and versatile performance, the SD-14620 Series converters are ideal for use in modern high-performance military, commercial and position control systems. Typical applications include radar antenna positioning, motor control, robotics, navigation and fire control systems.



Data Device Corporation
105 Wilbur Place
Bohemia, New York 11716
631-567-5600 Fax: 631-567-7358
www.ddc-web.com

FEATURES

- Synthesized Reference Option
- 1 Minute Accuracy Available (“S” Option only)
- Single +5 V Power Supply
- 10-, 12-, 14- or 16-Bit Programmable Resolution
- Small 54-Pin Ceramic Package
- $\overline{\text{BIT}}$ Output
- Velocity Output Replaces Tachometer
- High Reliability Single Chip Monolithic
- -55°C to +125°C Operating Temperature Range
- MIL-PRF-38534 Processing Available

FOR MORE INFORMATION CONTACT:

Technical Support:
1-800-DDC-5757 ext. 7771

All trademarks are the property of their respective owners.

© 1991, 1999 Data Device Corporation

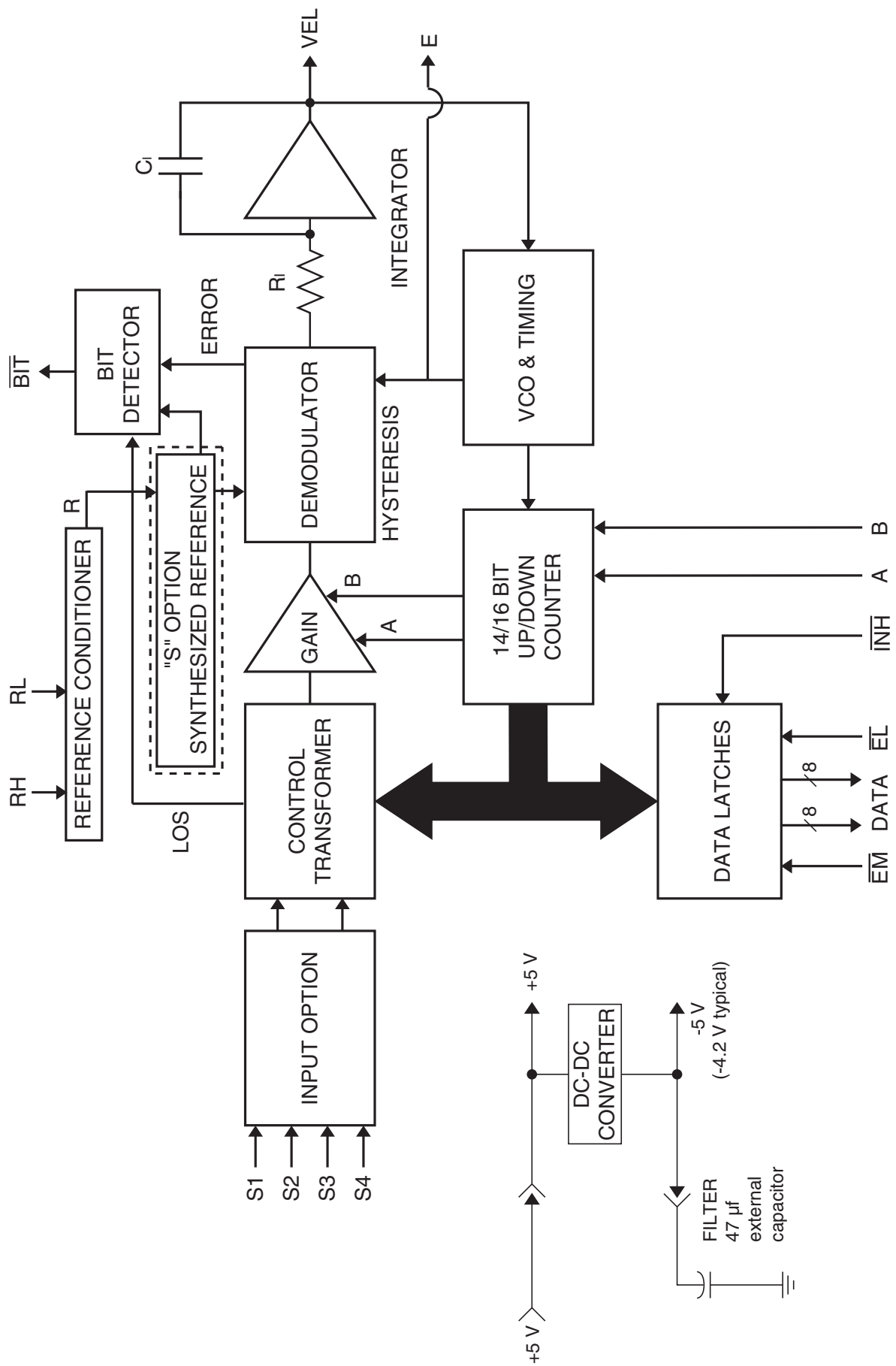

FIGURE 1. SD-14620 BLOCK DIAGRAM (ONE CHANNEL)

TABLE 1. SD-14620 SERIES SPECIFICATIONS (EACH CHANNEL)

These specs apply over the rated power supply, temperature, and reference frequency ranges;
10% signal amplitude variation, and 10% harmonic distortion.

| PARAMETER | UNIT | VALUE | |
|-------------------------------------|-------|---|---|
| RESOLUTION | Bits | programmable 10, 12, 14, or 16 | |
| ACCURACY | Min | ±1, ±2 or ±4, + 1 LSB (see TABLE 5) | |
| REPEATABILITY | LSB | 1 max. | |
| DIFFERENTIAL LINEARITY | LSB | 1 max. | |
| REFERENCE INPUT | | (RH, RL) Each Channel differential | |
| Type | | 2 & 11.8 V UNITS 90 V UNIT | |
| SD-14620 | | | |
| Voltage Range | Vrms | 2-35 | 10-130 |
| Frequency | Hz | 360 - 5K | 60 (47-5K) 400 (360-5K) |
| Input Impedance single ended | Ohm | 60K | 270K min. |
| differential | Ohm | 120K | 540K min. |
| Common-Mode Range | Vpeak | 50, 100 transient | 200, 300 transient |
| SD-14620XS | | | |
| Voltage Range | Vrms | 2-35 | — |
| Frequency | Hz | 1K - 5K | — |
| Input Impedance single ended | Ohm | 40K | — |
| differential | Ohm | 80K | — |
| Common-Mode Range | Vpeak | 50, 100 transient | — |
| ±Sig/Ref Phase Shift | deg. | 45 max | — |
| SIGNAL INPUT CHARACTERISTICS | | | |
| 90 V Synchro Input (L-L) | | | |
| Zin line-to-line | Ohm | | 123K |
| Zin line-to-ground | Ohm | | 80K |
| Common-Mode Voltage | V | | 180 max. |
| 11.8 V Synchro Input (L-L) | | | |
| Zin line-to-line | Ohm | | 52K |
| Zin line-to-ground | Ohm | | 34K |
| Common-Mode Voltage | V | | 30 max. |
| 11.8 V Resolver Input (L-L) | | | (same for "S" option) |
| Zin line-to-line | Ohm | | 140K |
| Zin line-to-ground | Ohm | | 70K |
| Common-Mode Voltage | V | | 30 max. |
| 2 V Direct Input (L-L) | | | |
| Voltage Range | Vrms | | 2 nom, 2.3 max. |
| Max. Voltage w/o Damage | V | | 25 cont, 100 pk transient |
| Input Impedance | Ohm | | 180K min. |
| 2 V Resolver Input (L-L) | | | ("S" option only) |
| Zin single ended | Ohm | | 11K |
| Zin differential | Ohm | | 22K |
| Common-Mode Voltage | V | | 4.9 max. |
| DIGITAL INPUT/OUTPUT | | | |
| Logic Type | | | TTL/CMOS compatible |
| INPUTS | | | Logic 0 = 0.8 V max. Logic 1 = 2.0 V min. Loading (per channel) = 10 μA max P.U. current source to +5 V 5 pF max. CMOS transient protected. |

THEORY OF OPERATION

The SD-14620 Series of converters are based upon a single chip CMOS custom monolithic. Using the latest technology, precision analog circuitry is merged with digital logic to form a complete, high-performance tracking Synchro/Resolver-to-Digital (S/D, R/D) converter.

CONVERTER OPERATION

FIGURE 1 is the Functional Block Diagram of the SD-14620 Series. The converter operates with a single +5 VDC power supply and each channel internally generates a negative voltage of approximately 5 volts. These negative voltages are connected to pin 52 (channel “A” filter point) and pin 24 (channel “B” filter point) — see GENERAL SETUP CONSIDERATIONS.

The converter is made up of three main sections; an input front-end, an error processor, and a digital interface. The converter front-end differs for synchro, resolver and direct inputs. An electronic Scott-T is used for synchro inputs, a resolver conditioner for resolver inputs, and a sine and cosine voltage follower for direct inputs. These amplifiers feed the high accuracy Control Transformer (CT). Its other input is the 16-bit digital angle ϕ . Its output is an analog error angle, or difference angle, between the two inputs. The CT performs the ratiometric trigonometric computation of $\text{SIN}\theta\text{COS}\phi - \text{COS}\theta\text{SIN}\phi = \text{SIN}(\theta - \phi)$ using amplifiers, switches, logic, and capacitors in precision ratios. The converter accuracy is limited by the precision of the computing elements in the CT. For enhanced accuracy, the CT in these converters use capacitors in precision ratios, instead of the more conventional precision resistor ratios. Capacitors that are used as computing elements with op-amps are sampled at a high rate to eliminate drift and the op-amp offsets.

The error processing is performed using the industry standard technique for type II tracking R/D converters. The DC error is integrated yielding a velocity voltage which in turn drives a voltage-controlled oscillator (VCO). This VCO is an incremental integrator (constant-voltage input to position-rate output) that, together with the velocity integrator, forms a type II servo feedback loop. A lead in the frequency response is introduced to stabilize the loop and a lag at a higher frequency is introduced to reduce the gain and ripple at the carrier frequency and above.

Dynamic accuracy may be degraded in applications with a high system bandwidth. This dynamic accuracy error is usually not an issue when using the device’s analog velocity output or position output data in a control-loop because they are inherently filtered due to comparatively low bandwidths in most applications.

TABLE 2. RESOLUTION CONTROL (A AND B)

| RESOLUTION | B | A |
|------------|---|---|
| 10 bit | 0 | 0 |
| 12 bit | 0 | 1 |
| 14 bit | 1 | 0 |
| 16 bit | 1 | 1 |

GENERAL SET-UP CONSIDERATIONS

The following recommendations should be considered when connecting the SD-14620 Series converters:

- 1) The +5 VDC power supply input is on pin 18. For performance with the lowest amount of noise it is recommended that a 10 μF /10 VDC (or larger) tantalum filter capacitor be connected to ground (pin 19) near the converter package.
- 2) Direct inputs are referenced to Analog Ground (A GND). Connections should be made as close to the converter package as possible to minimize noise. Channel A should be referenced to A GND-A (pin 5) and Channel B should be referenced to A GND-B (pin 32).
- 3) A 47 μF /10 V tantalum filter capacitor must be added externally from pin 52 (channel “A” filter point) to pin 19 (ground). In addition, a 47 μF /10 Vdc tantalum filter capacitor must be added externally from pin 24 (channel “B” filter point) to pin 19 (ground).

SPECIAL FUNCTIONS

PROGRAMMABLE RESOLUTION

Resolution is controlled by pins 49 and 50 for channel A; pins 21 and 22 for channel B. The resolution can be changed during converter operation, so the appropriate resolution and velocity dynamics can be changed as needed. To insure that a race condition does not exist between counting and changing the resolution, the resolution control is latched internally. Refer to TABLE 2 for Channel A and B resolution control.

TABLE 3. DIGITAL ANGLE OUTPUTS

| BIT | DEG/BIT | MIN/BIT |
|----------------------|---------|---------|
| 1 (MSB ALL MODES) | 180 | 10800 |
| 2 | 90 | 5400 |
| 3 | 45 | 2700 |
| 4 | 22.5 | 1350 |
| 5 | 11.25 | 675 |
| 6 | 5.625 | 337.5 |
| 7 | 2.813 | 168.75 |
| 8 | 1.406 | 84.38 |
| 9 | 0.7031 | 42.19 |
| 10 (LSB 10-BIT MODE) | 0.3516 | 21.09 |
| 11 | 0.1758 | 10.55 |
| 12 (LSB 12-BIT MODE) | 0.0879 | 5.27 |
| 13 | 0.0439 | 2.64 |
| 14 (LSB 14-BIT MODE) | 0.0220 | 1.32 |
| 15 | 0.0110 | 0.66 |
| 16 (LSB 16-BIT MODE) | 0.0055 | 0.33 |

Note: $\overline{\text{EM}}$ enables the MSB byte and $\overline{\text{EL}}$ enables the LSB byte.

BIT, (BUILT-IN-TEST)

This output is an active low logic line that will flag an internal fault condition or LOS (Loss-Of-Signal). The internal fault detector monitors the internal loop error and, when it exceeds approximately 100 LSBs of positive error or 250 LSBs of negative error, will set the line to a logic 0. This condition will occur during a large-step input and will reset to a logic 1 after the converter settles out. (The BIT is filtered with a 500 μ s delay.) BIT will set for an overvelocity condition because the converter loop can not maintain input/output sync. For the “S” option only, this output will be active low for an LOR (Loss-Of-Reference) fault condition.

NO FALSE 180° HANGUP

The converter is designed to eliminate a “false 180° reading” during instantaneous 180° step changes. This condition most often occurs when the input is “electronically switched” from a Digital-to-Synchro converter. If the “MSB” (or 180° bit) is “toggled” on and off, a converter without the “false 180° hangup” feature may fail to respond. The condition is artificial, as a “real” synchro or resolver cannot change its output 180° instantaneously. The condition is most often noticed during wraparound verification tests, simulations, or troubleshooting.

SYNTHESIZED REFERENCE

The synthesized reference section (“S” option) eliminates errors due to phase shift between the reference and signal inputs of up to 45°. Quadrature voltages in a resolver or synchro are by definition the resulting 90° fundamental signal in the nulled out error voltage (e) in the converter. Due to the inductive nature of synchros and resolvers, their output signals lead the reference input signal (RH and RL). When an uncompensated reference signal is used to demodulate the control transformer’s output, quadrature voltages are not completely eliminated. As shown in FIGURE 1, the converter synthesizes its own internal reference signal based on the SIN and COS signal inputs. Therefore, the phase of the synthesized (internal) reference is determined by the signal input, resulting in reduced quadrature errors. The synthesized reference circuit also eliminates the 180 degree false error null hang up.

E

The DC error signal “E” is a voltage that is proportional to the error ($\theta - \phi$) near the null point, with -1.25 VDC output per +LSB of error. (θ = input data angle, ϕ = angle in up/down counter).

INTERFACING

SOLID-STATE BUFFER PROTECTION - TRANSIENT VOLTAGE SUPPRESSION

The solid-state signal and reference inputs are true differential inputs with high AC and DC common rejection, so most applications will not require units with isolation transformers. Input impedance is maintained with power off. The recurrent AC peak + DC common-mode voltage should not exceed the values in TABLE 1.

The 90 V line-to-line systems may have voltage transients which exceed the 300 V specification listed in TABLE 1. **These transients can destroy the thin-film input resistor network in the hybrid.** Therefore, 90 V L-L solid-state input modules may be protected by installing voltage suppressors (See FIGURE 2). Voltage transients are likely to occur whenever a synchro is switched on and off. For instance, a 1000 V transient can be generated when the primary of a CX or TX input is opened.

INHIBIT AND ENABLE TIMING

The Inhibit (INH) signal is used to freeze the digital output angle in the transparent output data latch while the data is being transferred. Application of an inhibit signal does not interfere with the continuous tracking of the converter. As shown in FIGURE 3, angular output data is valid 500 nanoseconds (maximum) after the application of the low-going Inhibit pulse.

Output angle data is enabled onto the tri-state data bus in 16 bits. This Enable MSB (EM-A or EM-B) is used for the most sig-

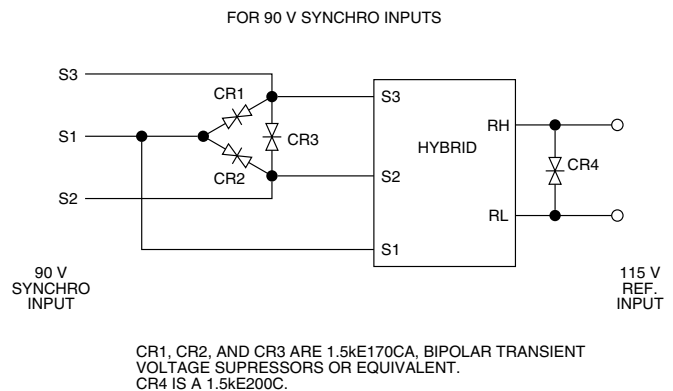

FIGURE 2. CONNECTIONS FOR VOLTAGE TRANSIENT SUPPRESSORS

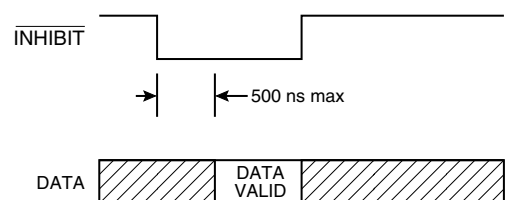

FIGURE 3. INHIBIT TIMING

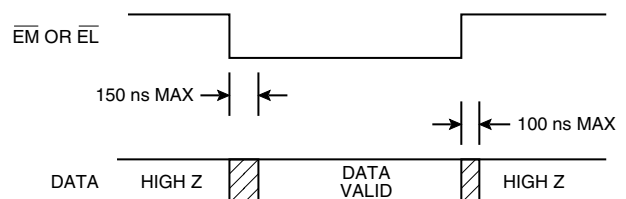

FIGURE 4. ENABLE TIMING

TABLE 4. DYNAMIC CHARACTERISTICS

| EACH CHANNEL | | DEVICE TYPE | | | | | | | | | | | |
|-------------------------------|--------------------|-------------|-----|------|------|----------|------|-----|-----|------------|------|------|-----|
| | | 60 Hz | | | | 400 Hz | | | | "S" OPTION | | | |
| | | 10 | 12 | 14 | 16 | 10 | 12 | 14 | 16 | 10 | 12 | 14 | 16 |
| Input Frequency | Hz | 47 - 5K | | | | 360 - 5K | | | | 1K - 5K | | | |
| Bandwidth (Closed Loop) | Hz | 15 | | | | 56 | | | | 150 | | | |
| Ka | 1/s ² | 830 | | | | 17K | | | | 110K | | | |
| A1 | 1/s | 0.17 | | | | 0.41 | | | | 2.47 | | | |
| A2 | 1/s | 5K | | | | 41K | | | | 44.4K | | | |
| A | 1/s | 29 | | | | 130 | | | | 333 | | | |
| B | 1/s | 14.5 | | | | 81 | | | | 166 | | | |
| RESOLUTION | BITS | 10 | 12 | 14 | 16 | 10 | 12 | 14 | 16 | 10 | 12 | 14 | 16 |
| Tracking Rate (rps) | rps | 32 | 8 | 2 | 0.5 | 160 | 40 | 10 | 2.5 | 160 | 40 | 10 | 2.5 |
| typical (Note 1) | rps | 25.6 | 6.4 | 1.6 | 0.4 | 128 | 32 | 8 | 2 | 128 | 32 | 8 | 2 |
| minimum | rps | 720 | 180 | 45 | 11.3 | 5950 | 1490 | 372 | 93 | 39K | 9760 | 2440 | 610 |
| Acceleration (1 LSB lag) | deg/s ² | 400 | 500 | 1100 | 2500 | 90 | 100 | 180 | 360 | 51 | 78 | 150 | 232 |
| Settling Time (179° step max) | msec | | | | | | | | | | | | |

Note 1: Velocity output is scaled for 3.5V at typical tracking rates per resolution shown.

nificant 8 bits and Enable LSB ($\overline{EL-A}$ or $\overline{EL-B}$) is used for the least significant bits. As shown in FIGURE 4, output data is valid 150 nanoseconds (maximum) after the application of a low-going enable pulse. The tri-state data bus returns to the high impedance state 100 nanoseconds (maximum) after the rising edge of the enable signal.

DYNAMIC PERFORMANCE

A type II servo loop ($K_v = \infty$) and very high acceleration constants give the SD-14620 superior dynamic performance.

TRANSFER FUNCTION AND BODE PLOT

The dynamic performance of the converter can be determined from its Functional Block Diagram (FIGURE 1), its transfer function block diagram (FIGURE 5), and its Bode Plots (open and closed loop - FIGURE 6). Values for the transfer function block can be obtained from TABLE 4.

The open loop transfer function is as follows:

$$\text{Open Loop Transfer Function} = \frac{A^2 \left(\frac{S}{B} + 1 \right)}{S^2 \left(\frac{S}{10B} + 1 \right)}$$

where A is the gain coefficient
and B is the frequency of lead compensation

ACCURACY AND RESOLUTION

TABLE 5 lists the total accuracy including quantification of the various resolutions and accuracy grades.

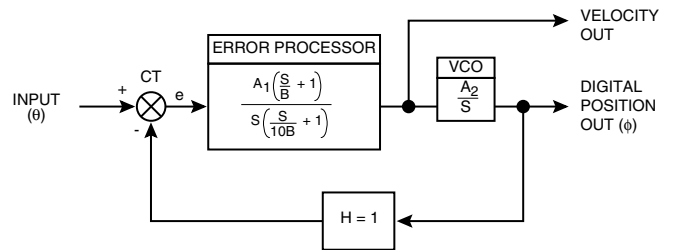

$$\text{Open Loop Transfer Function} = \frac{A^2 \left(\frac{S}{B} + 1 \right)}{S^2 \left(\frac{S}{10B} + 1 \right)} \quad \text{WHERE: } A^2 = A_1 A_2$$

FIGURE 5. TRANSFER FUNCTION BLOCK DIAGRAM

| TABLE 5. ACCURACY/RESOLUTION | | | | | |
|------------------------------|--------------------|----------------------|--------|--------|--------|
| VERSION | ACCURACY (minutes) | RESOLUTION (minutes) | | | |
| | | 10 BIT | 12 BIT | 14 BIT | 16 BIT |
| SD-1462X-XX | ±4 +1 LSB | 42.2 | 10.5 | 5.3 | 4.3 |
| | ±2 +1 LSB | 42.2 | 10.5 | 3.3 | 2.3 |
| SD-1462X-XS ("S" option) | ±4 +1 LSB | 25.1 | 9.3 | 5.3 | 4.3 |
| | ±2 +1 LSB | 23.1 | 7.3 | 3.3 | 2.3 |
| | ±1 +1 LSB | 22.1 | 6.3 | 2.3 | * 1.3 |

* 1.3 minute accuracy available for "S" option only. Inclusive of 1 bit of jitter.

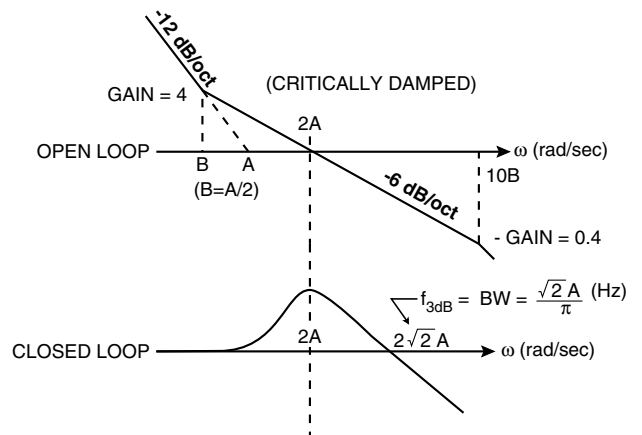

FIGURE 6. BODE PLOTS

TABLE 6. PINOUTS (DIP AND FLAT PACK)

| PIN | FUNCTION | | | PIN | FUNCTION | | |
|-----|--|---------|-----------|-----|--|---------|----------|
| 1 | S1-A(R) | S1-A(S) | N.C. | 54 | VEL A (Velocity - chan. A) | | |
| 2 | S2-A(R) | S2-A(S) | +COS-A(D) | 53 | E (DC error - channel A) | | |
| 3 | S3-A(R) | S3-A(S) | +SIN-A(D) | 52 | Filter Point - channel A | | |
| 4 | S4-A(R) | N.C. | N.C. | 51 | $\overline{\text{INH}}$ -A (Inhibit chan. A) | | |
| 5 | A GND-A (analog gnd. chan. A) | | | 50 | resolution control B (chan. A) | | |
| 6 | RH-A (+Ref. Input chan. A) | | | 49 | resolution control A (chan. A) | | |
| 7 | RL-A (-Ref. Input chan. A) | | | 48 | $\overline{\text{EL}}$ -A (Enable LSBs chan. A) | | |
| 8 | $\overline{\text{EM}}$ -A (Enable MSBs chan. A) | | | 47 | N.C. | | |
| 9 | $\overline{\text{BIT}}$ -A (Built-In-Test chan. A) | | | 46 | Bit 16 (LSB, 16-bit mode) | | |
| 10 | Bit 1 (MSB) | | | 45 | Bit 8 | | |
| 11 | Bit 9 | | | 44 | Bit 15 | | |
| 12 | Bit 2 | | | 43 | Bit 7 | | |
| 13 | Bit 10 (LSB, 10-bit mode) | | | 42 | Bit 14 (LSB, 14-bit mode) | | |
| 14 | Bit 3 | | | 41 | Bit 6 | | |
| 15 | Bit 11 | | | 40 | Bit 13 | | |
| 16 | Bit 4 | | | 39 | Bit 5 | | |
| 17 | Bit 12 (LSB, 12-bit mode) | | | 38 | $\overline{\text{BIT}}$ -B (Built-In-Test chan. B) | | |
| 18 | +5 V (Power Supply) | | | 37 | $\overline{\text{EM}}$ -B (Enable MSBs chan. B) | | |
| 19 | GND (Ground) | | | 36 | N.C. | | |
| 20 | $\overline{\text{EL}}$ -B (Enable LSBs chan. B) | | | 35 | RL-B (-Ref. Input chan. B) | | |
| 21 | resolution control A (channel B) | | | 34 | RH-B (+Ref. Input chan. B) | | |
| 22 | resolution control B (channel B) | | | 33 | N.C. | | |
| 23 | $\overline{\text{INH}}$ -B (Inhibit - chan. B) | | | 32 | A GND-B (analog gnd. chan. B) | | |
| 24 | Filter Point - channel B | | | 31 | S4-B(R) | N.C. | N.C. |
| 25 | E (DC error - channel B) | | | 30 | S3-B(R) | S3-B(S) | SIN-B(D) |
| 26 | VEL B (Velocity - chan. B) | | | 29 | S2-B(R) | S2-B(S) | COS-B(D) |
| 27 | N.C. | | | 28 | S1-B(R) | S1-B(S) | N.C. |

Notes:

- (S) = Synchro; (R) = Resolver; (D) = 2 V Resolver Direct.
- Connect a 47 μF /10 VDC tantalum filter cap from pin 24 to pin 19.
- Connect a 47 μF /10 VDC tantalum filter cap from pin 52 to pin 19.
- Connect a 10 μF /10 VDC tantalum filter cap from pin 18 to pin 19.

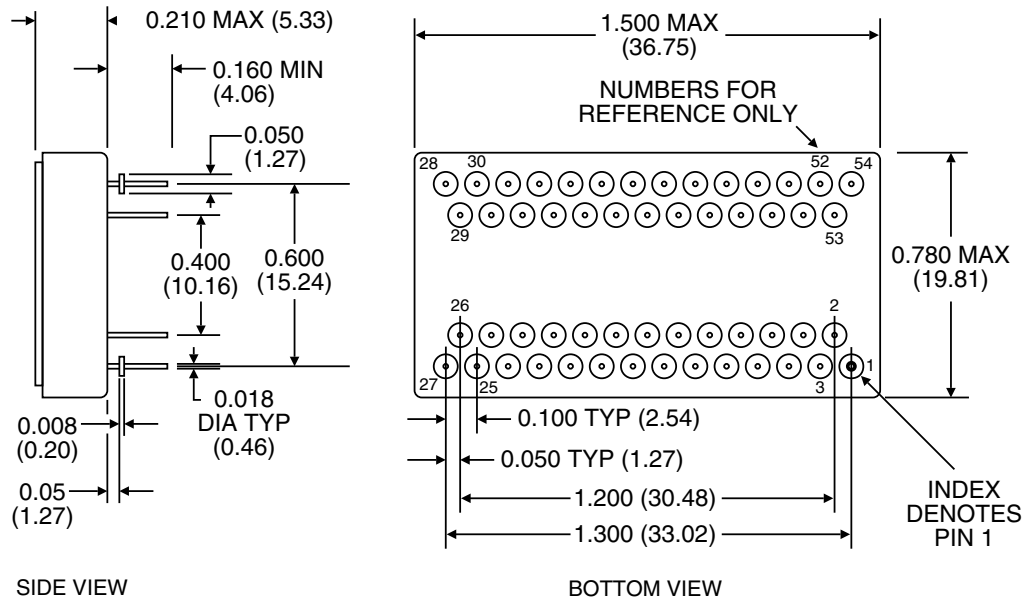

Notes:

1. Dimensions are in inches (mm).
2. Lead identification numbers are for reference only
3. Lead cluster shall be centered within ± 0.005 (0.13) of outline dimensions.
Lead spacing dimensions apply only at seating plane.
4. Pin material meets solderability requirements to MIL-STD-202E, Method 208C.
5. Case is hermetically sealed ceramic package.

FIGURE 7. SD-14620 DIP MECHANICAL OUTLINE

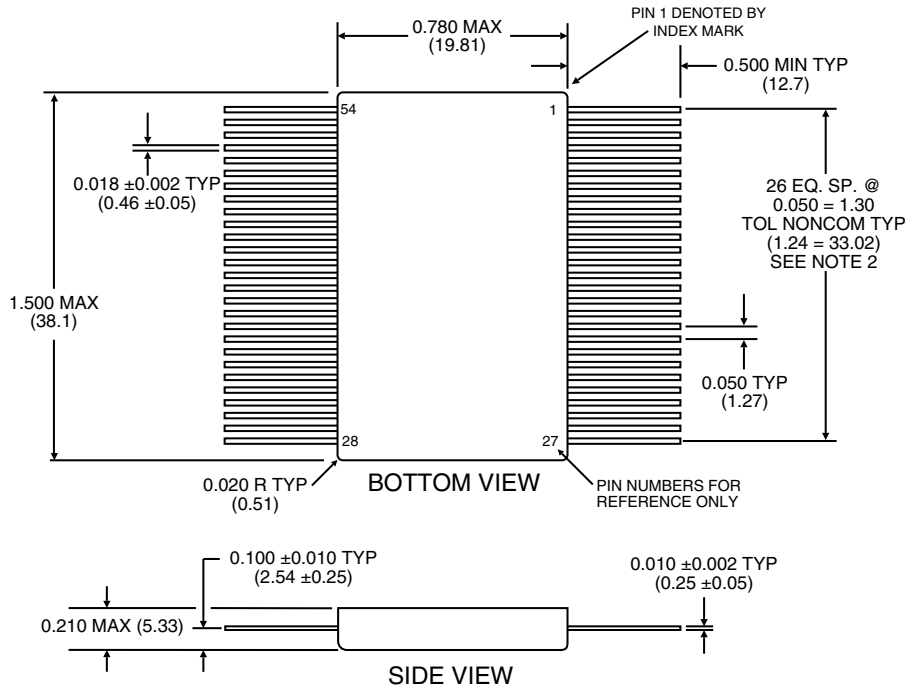

Notes:

1. Dimensions are in inches (mm).
2. Lead cluster shall be centralized about case centerline within ± 0.010 (± 0.254).

FIGURE 8. SD-14620 FLAT PACK MECHANICAL OUTLINE

ORDERING INFORMATION

SD-1462X X X - X X X X

Supplemental Process Requirements:

S = Pre-Cap Source Inspection
L = 100% Pull Test
Q = 100% Pull Test and Pre-Cap Source Inspection
K = One Lot Date Code
W = One Lot Date Code and Pre-Cap Source Inspection
Y = One Lot Date Code and 100% Pull Test
Z = One Lot Date Code, Pre-Cap Source Inspection and 100% Pull Test
Blank = None of the Above

Accuracy: (non "S" option)

2 = ± 4 min + 1 LSB
4 = ± 2 min + 1 LSB

Accuracy: ("S" option) (Note 3)

2 = ± 4 min + 1 LSB
4 = ± 2 min + 1 LSB
5 = ± 1 min + 1 LSB

Reliability Grade:

0 = Standard DDC Processing, no Burn-In (See table on next page.)
1 = MIL-PRF-38534 Compliant (note 2)
2 = B (note 1)
3 = MIL-PRF-38534 Compliant (note 2) with PIND Testing
4 = MIL-PRF-38534 Compliant (note 2) with Solder Dip
5 = MIL-PRF-38534 Compliant (note 2) with PIND Testing and Solder Dip
6 = B (note 1) with PIND Testing
7 = B (note 1) with Solder Dip
8 = B (note 1) with PIND Testing and Solder Dip
9 = Standard DDC Processing with Solder Dip, no Burn-In (See table on next page.)

Temperature Grade/Data Requirements:

1 = -55°C to +125°C
2 = -40° to +85°C
3 = 0°C to +70°C
4 = -55°C to +125°C + Variables Test Data
5 = -40°C to +85°C + Variables Test Data
8 = 0°C to +70°C + Variables Test Data

Options:

X = None
S = Synthesized Reference (note 3)

Package Type:

D = DIP
F = Flat Pack

Input Options: (non "S" option) (Note 4)

0 = 11.8 V, Synchro, 400 Hz
1 = 11.8 V, Resolver, 400 Hz
2 = 90 V, Synchro, 400 Hz
3 = 2 V, Direct, 400 Hz
4 = 90 V, Synchro, 60 Hz

Input Options: ("S" Option) (Notes 3, 4)

1 = 11.8 V, Resolver, 1 KHz
3 = 2 V, Resolver (Differential), 1 KHz

Notes:

1. Standard DDC processing with burn-in and full temperature test. See table on next page.
2. MIL-PRF-38534 product grading is designated with the following dash numbers:
Class H is a -11X, 13X, 14X, 15X, 41X, 43X, 44X, 45X
Class G is a -21X, 23X, 24X, 25X, 51X, 53X, 54X, 55X
Class D is a -31X, 33X, 34X, 35X, 81X, 83X, 84X, 85X
3. When choosing synthesized reference, all options must be from the "S" option categories.
4. See TABLE 4 for full frequency range specifications.
5. These products contain tin-lead solder finish as applicable to solder dip requirements.

| STANDARD DDC PROCESSING FOR HYBRID AND MONOLITHIC HERMETIC PRODUCTS | | |
|--|------------------------------|--------------|
| TEST | MIL-STD-883 | |
| | METHOD(S) | CONDITION(S) |
| INSPECTION | 2009, 2010, 2017, and 2032 | — |
| SEAL | 1014 | A and C |
| TEMPERATURE CYCLE | 1010 | C |
| CONSTANT ACCELERATION | 2001 | 3000g |
| BURN-IN | 1015 (note 1), 1030 (note 2) | TABLE 1 |

Notes:

1. For Process Requirement "B*" (refer to ordering information), devices may be non-compliant with MIL-STD-883, Test Method 1015, Paragraph 3.2. Contact factory for details.
2. When applicable.

The information in this data sheet is believed to be accurate; however, no responsibility is assumed by Data Device Corporation for its use, and no license or rights are granted by implication or otherwise in connection therewith. Specifications are subject to change without notice.



®Data Device Corporation

105 Wilbur Place, Bohemia, New York 11716-2426

For Technical Support - 1-800-DDC-5757 ext. 7771

Headquarters, N.Y., U.S.A. -Tel: (631) 567-5600, Fax: (631) 567-7358

United Kingdom - Tel: +44-(0)1635-811140, Fax: +44-(0)1635-32264

France - Tel: +33-(0)1-41-16-3424, Fax: +33-(0)1-41-16-3425

Germany - Tel: +49-(0)89-15 00 12-11, Fax: +49-(0)89-15 00 12-22

Japan - Tel: +81-(0)3-3814-7688, Fax: +81-(0)3-3814-7689

Asia - Tel: +65-6489-4801

World Wide Web - <http://www.ddc-web.com>



DATA DEVICE CORPORATION
REGISTERED TO:
ISO 9001:2008, AS9100C:2009-01
EN9100:2009, JIS Q9100:2009
FILE NO. 10001296 ASH09

