

## 1063 Mbps Gigabit Link Module - No OFC

---

### Features

- 1063 Mbps data rate
- Short wavelength (SW; distance  $\leq$  500 m) and long wavelength (LW; distance  $\leq$  10 km) versions available
- (ANSI) Fibre Channel compliant (longer distances are available on a custom basis)
- FCSI-301-Revision 1.0 compliant (Gigabaud Link Module)
- 20-bit electrical interface
- Parallel electrical  $\leftrightarrow$  light conversion
- Clock and data recovery
- Serialization/deserialization
- International Class 1 laser safety certified
- UL & CSA approved
- Low bit error rate ( $<10^{-12}$ )
- High reliability (AFR  $<0.0195\%$ /khr, over 44 khours)

### Applications

- Fibre Channel
- Client/Server environments
- Distributed multi-processing
- Fault tolerant applications
- Visualization, real-time video, collaboration
- Channel extenders, data storage, archiving
- Data acquisition

---

### Overview

IBM42M10SNYAA20 and IBM42M10LNYAA10 are 1063 Mbps Gigabit Link Modules (GLMs). These highly integrated fiber optic transceivers provide high-speed serial links at a signaling rate of 1062.5 Mbps, which equates to 100 MBps of continuous throughput simultaneously in each direction. The IBM42M10SNYAA20 conforms to the American National Standards Institute's (ANSI) Fibre Channel, FC-0 specification for short wavelength operation (100-M5-SL-I and 100-M6-SL-I) [1]. The IBM42M10LNYAA10 conforms to the ANSI FC-0 specification for longwave operation (100-SM-LL-I). These modules can also be used for other serial applications where high data rates are required. They are compact, double-sided, surface mount modules designed to easily connect to a user's system card. Data and control lines conform to industry standard TTL interface levels.

The IBM42M10SNYAA20 uses short wavelength (850 nm) VCSEL lasers. This enables low cost data transmission over optical fibers at distances up to

500 m. A 50/125  $\mu$ m multimode optical fiber, terminated with an industry standard SC connector, is the preferred medium. A 62.5/125  $\mu$ m multimode fiber can be substituted with shorter maximum link distances.

The IBM42M10LNYAA10 uses long wavelength (1300 nm) lasers. This enables data transmission over optical fibers at distances up to 10km on a single mode (9/125  $\mu$ m) optical fiber.

Twenty-bit encoded transmit data is received, serialized at 1062.5 Mbaud, and modulated on the laser. The 20-bit data must be encoded using the 8b/10b encoding scheme [3, 4] specified by the Fibre Channel standard.

Incoming, modulated light is received by a photoreceiver mounted in the SC receptacle. A Phase Locked Loop (PLL) recovers the clock and retimes the serial data which is deserialized into a 20-bit word and presented to the interface at 53.125 MHz.

## Pin Configuration

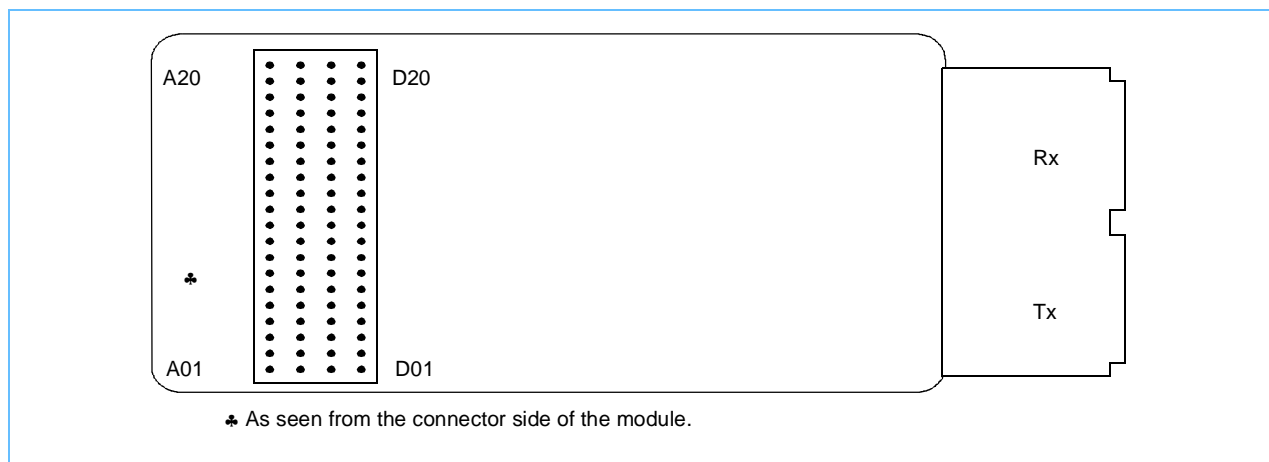

## Pin Definitions

Pin	Signal	Note	Pin	Signal	Note	Pin	Signal	Note	Pin	Signal	Note
A01	N/C	1	B01	N/C	1	C01	Ground		D01	N/C	1
A02	Ground		B02	Ground		C02	Ground		D02	N/C	1
A03	V <sub>CC</sub>		B03	Tx[10]		C03	Tx [00]		D03	V <sub>CC</sub>	
A04	Tx[12]		B04	Tx[11]		C04	Tx [02]		D04	Tx [01]	
A05	Tx[14]		B05	Tx[13]		C05	Tx [04]		D05	Tx [03]	
A06	Tx[16]		B06	Tx[15]		C06	Tx [06]		D06	Tx [05]	
A07	Tx[18]		B07	Tx[17]		C07	Tx [08]		D07	Tx [07]	
A08	Ground		B08	Tx[19]		C08	Tx [09]		D08	Ground	
A09	Strobed ID	2	B09	Ground		C09	Ground		D09	V <sub>CC</sub>	
A10	V <sub>CC</sub>		B10	Link Unusable		C10	Fault		D10	TBC	
A11	Parallel ID [1]	3	B11	Reserved	4	C11	Transmit SI (N/C)		D11	Parallel ID [0]	3
A12	RBC[0]		B12	Enable Wrap		C12	Comma Detect		D12	V <sub>CC</sub>	
A13	V <sub>CC</sub>		B13	Ground		C13	Reserved	5	D13	RBC [1]	
A14	Ground		B14	Rx[10]		C14	Rx [00]		D14	Ground	
A15	Rx[12]		B15	Rx[11]		C15	Rx [02]		D15	Rx [01]	
A16	Rx[14]		B16	Rx[13]		C16	Rx [04]		D16	Rx [03]	
A17	Rx[16]		B17	Rx[15]		C17	Rx [06]		D17	Rx [05]	
A18	Rx[18]		B18	Rx[17]		C18	Rx [08]		D18	Rx [07]	
A19	V <sub>CC</sub>		B19	Rx[19]		C19	Rx [09]		D19	V <sub>CC</sub>	
A20	Enable Comma Detect		B20	Ground		C20	Ground		D20	<u>Lock to Reference</u>	

1. The serial I/O functions of this card are not implemented. The Serial I/O lines are left open on the GLM.
2. The Strobed ID function is now implemented. This function is new.
3. The Parallel ID bits are tied to V<sub>CC</sub> through 10kΩ resistors.
4. Pin B11 is a reserved input. It is left open.
5. Pin C13 is a reserved output. It is left open.



## Ordering Information

Part Number	Signalling Rate	Optical Fibre Control	Wavelength
IBM42M10SNYAA20	1062.5 Mbps	No	850 nm
IBM42M10LNYAA10	1062.5 Mbps	No	1300 nm

## Exceptions to GLM and Fibre Channel Specifications

IBM42M10SNYAA20 and IBM42M10LNYAA10 comply with the Fibre Channel (100-M5-SL-I, 100-M6-SL-I 100-SM-LL-I) and GLM specifications except for the following:

- The GLM specification [1] requires that the Fault line be reset by toggling the EWrap signal. IBM42M10SNYAA20 and IBM42M10LNYAA10 do not operate this way. The Fault line is reset only when it has been determined that the laser is operating correctly.
- The optical receptacles on the end of the IBM42M10LNYAA10 (long wavelength) do not contain the Fibre Channel specified “single mode keying” features. Either singlemode or multimode Fibre Channel compliant SC duplex connectors can be inserted into the ports of this GLM.

## Laser Safety Compliance Requirements

The IBM42M10SNYAA20 and IBM42M10LNYAA10 are designed and certified as Class 1 laser products. They are to be used only with another IBM-produced IBM42M10SNYAA20 or IBM42M10LNYAA10, or a certified equivalent in a point-to-point configuration. This is a requirement for proper operation of IBM42M10SNYAA20 and IBM42M10LNYAA10.

If the power supply voltage runs over 6.0 volts this GLM may no longer remain a Class 1 product. The system using the GLM must provide power supply protection that guarantees no voltage in excess of 6.0 volts under all fault conditions.

Connection of a GLM to a non-approved optical source, operating the power supply above 6.0 V, or otherwise operating the GLM in a manner inconsistent with its design and function may result in hazardous radiation exposure, and may be considered an act of modifying or new manufacturing of a laser product under US regulations contained in 21 CFR(J) or CENELEC regulations contained in EN 60825.

The person(s) performing such an act is required by law to recertify and reidentify the product in accordance with the provisions of 21 CFR(J) for distribution within the USA, and in accordance with provisions of CENELEC EN 60825 (or successive regulations) for distribution within the CENELEC countries or countries using the IEC 825 standard.

## Block Diagram

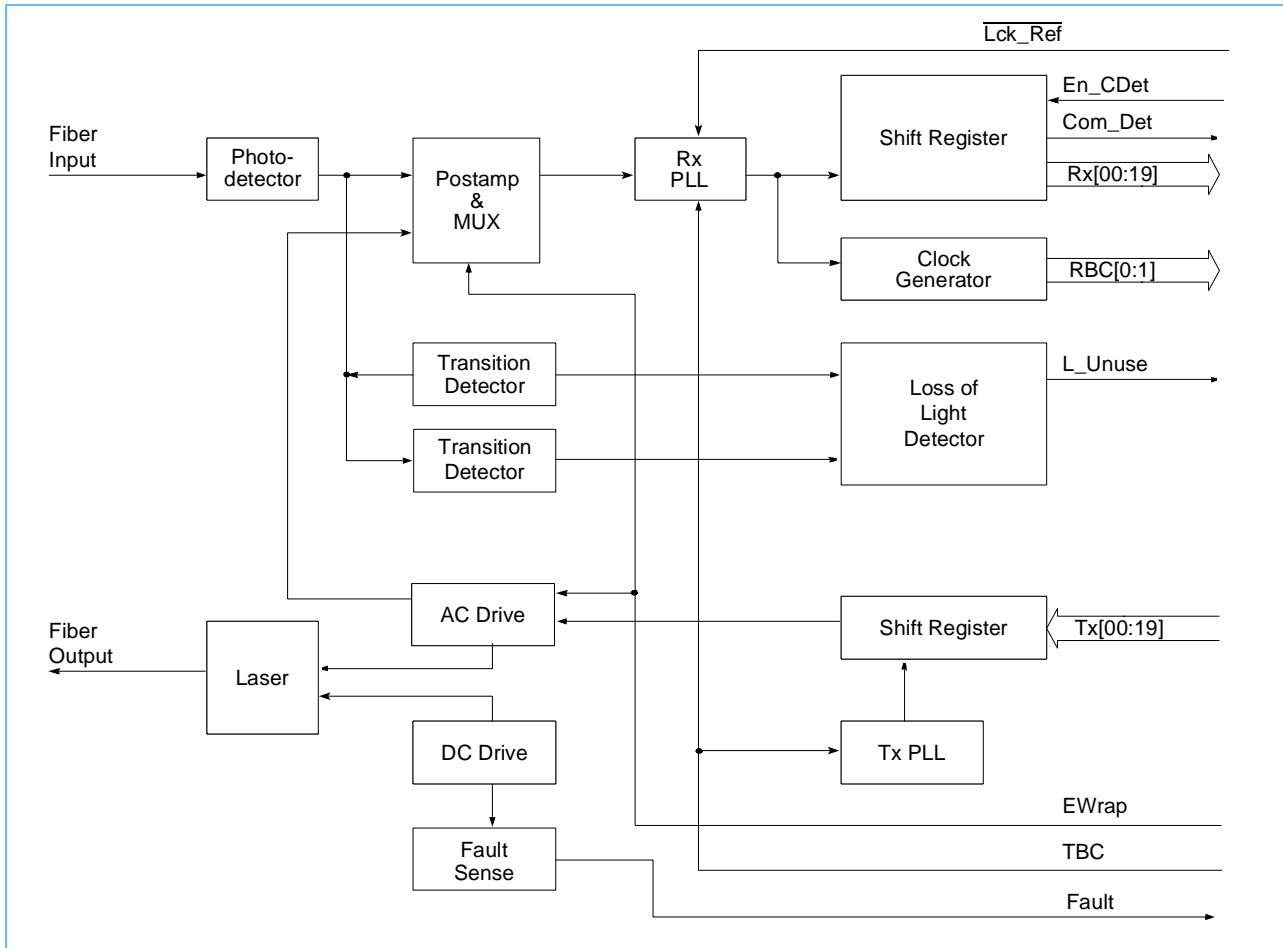

### Transmit Section

The 20-bit transmit data enters the shift register and is clocked out at 1062.5 Mbps to the serial output pins and the multiplexer. The AC Drive modulates the laser with the data from the Serial Input pins or the serialized version of the Transmit Data. The Transmit Phase Locked Loop (Tx PLL) generates the internal 1062.5 MHz clock for the shift register from the 53.125 MHz Transmit Byte Clock provided by the system. The DC Drive maintains the laser at the correct preset power level. Safety circuits in the DC Drive will shut off the laser if a fault is detected. The multiplexer is used to route the serialized data to the Receive Section while in wrap mode.

### Receive Section

The incoming, modulated optical signal is received by the photoreceiver. The Receive PLL (Rx PLL) phase locks a 1062.5 MHz clock to the data and sends the data and clock to the shift register (S/R) to be deserialized. The S/R has a byte synchronization detector that recognizes a unique Comma Character so that complete bytes can be unloaded from the S/R without being fragmented. The Clock Generator creates two complementary phases of a 53.125 MHz clock for use by the host system to latch the Receive Data.

## Output Signal Definitions

Levels for the signals described in this section are listed in Digital Outputs on page 14.

### Receive Byte Clocks (RBC[0:1])

The Clock Generator generates two clock signals, 180 degrees out of phase, for use in clocking the parallel data (Rx[00:19]). Each of the Receive Byte Clocks has a nominal 53.125 MHz frequency. The timing of these clocks is shown in the Receive Timings diagram below. If the Enable Comma Detect Signal is active, these clocks will be reset any time that a Comma Character is received (see Comma Detect (Com\_Det) on page 6 and Transmit and Lock to Reference Timings on page 8).

If a stream of Comma Characters (transmitted on both Tx[00:09] and Tx[10:19]) is received, RBC[0:1] will not operate properly. Having adjacent Comma Characters violates 8b/10b coding.

If there is no modulated light into the receiver or the PLL is out of lock for some other reason, the Receive Byte Clocks will operate at an unknown frequency between 27 and 106 MHz.

### Receive Data (Rx[00:19])

These 20 lines are used to output the deserialized data to the system logic in parallel. Rx00 is received at the photoreceiver first. Rx19 is received last. The relationship between the Receive Byte Clocks and Receive Data is shown in the Receive Timings diagram below. The Comma Character will always be aligned on Rx[00:09].

### Receive Timings

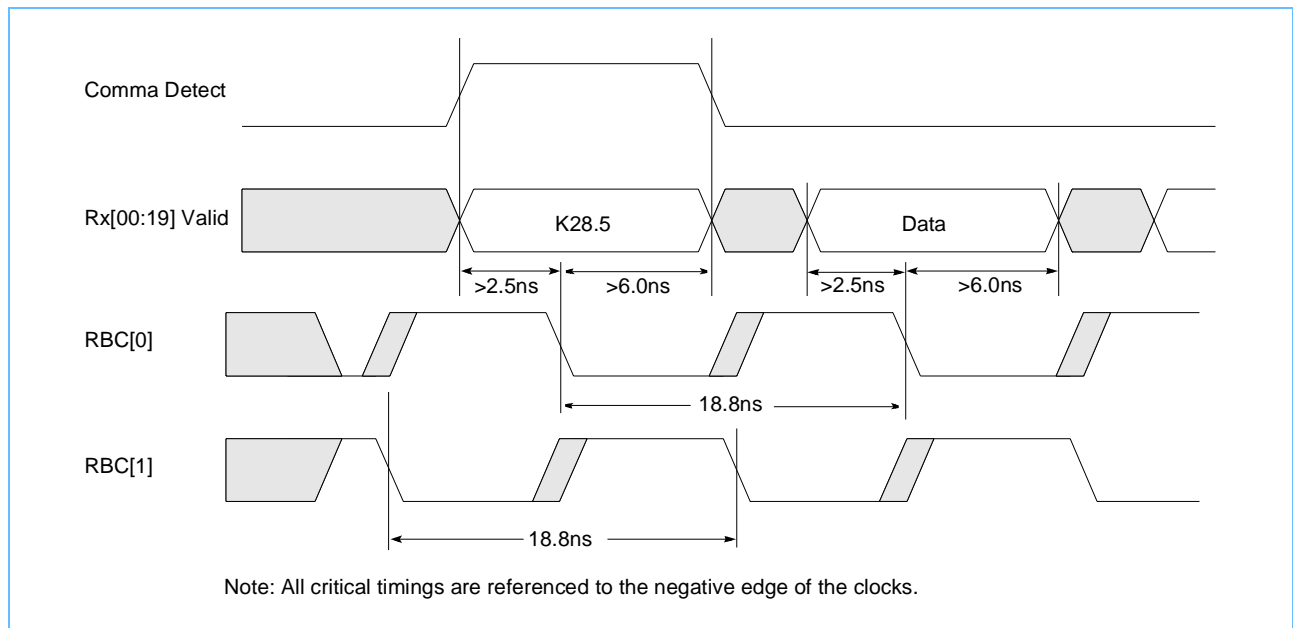

If there is no modulated light into the receiver or the Receive PLL is out of lock for some other reason, the Receive Data lines change randomly.



In most applications, it is assumed that the byte sync character will be transmitted on Tx[00:09]. If the byte sync is transmitted on Tx[10:19], it will still be received on Rx[00:09]. The Comma Character must always be sent on the even boundary. (Fibre Channel requires word boundaries.)

**Comma Detect (Com\_Det)**

This signal is driven high for one cycle whenever a Comma Character is detected by the deserializer; the Receive Byte Clocks are also reset. The Comma Character (K28.5) is described in [3].

This function is referred to in the Fibre Channel standard [1] as *byte alignment*. The K28.5 Comma Character is defined with two polarities. The GLM only detects the polarity shown in the Comma Character Description table below.

When the Enable Comma Detect line is high, the Receive Byte Clocks and the byte boundary are aligned upon receiving a Comma Character. In some applications, including Fibre Channel, this Comma Detect character is sent out frequently. Many of these applications wish to (re)align the byte boundary relative to the Receive Byte Clocks whenever a Comma Character is received (Enable Comma Detect line is kept high). One of the disadvantages of this approach is that in the event of a bit error there is a possibility that a Comma Character will be created and the OLM will change its byte boundary and thereby cause all subsequent data to be erroneous until the next Comma Character is received. The decision to keep the Enable Comma Detect line high should be based on the user's application.

One oddity with the current Comma Detect function is that a low Enable Comma Detect only quits detecting a Comma Character after one has been received.

If there is no modulated light into the receiver or the PLL is out of lock for some other reason, the Comma Detect line will pulse randomly.

The Comma Detect function can be disabled with the Enable Comma Detect input signal. This is described in Enable Comma Detect (En\_CDet) on page 9.

The Comma Detect function will not operate properly if a stream of Comma Characters is transmitted.

**Comma Character Description**

	Data Bits									
	Rx00	Rx01	Rx02	Rx03	Rx04	Rx05	Rx06	Rx07	Rx08	Rx09
8b/10b Designation <sup>1</sup>	a	b	c	d	e	i	f	g	h	j
Logic Level	0	0	1	1	1	1	1	X	X	X

1. The alphabetical notation (a, b, c, d, e, i, f, g, h, j) conforms to the 8b/10b code description in [3], but is not used in this document because of the confusion frequently caused by these alpha characters being out of alphabetical order.



### Link Unusable (L\_Unuse)

When this line is high it indicates that the fiber path is open. The Link Unusable line goes high within 650  $\mu$ s of the disruption of the incoming received signal. This signal is used in the Link Acquisition Sequence, as specified on page 11.

### Fault (Fault)

Upon sensing an improper power level in the laser driver, the GLM sets this signal high and turns off the laser within 100  $\mu$ s.

The GLM specification [2] requires that the Fault line be reset by toggling the EWrap signal. The GLM, however, resets the Fault line only after it has determined that the laser is operating correctly.

### Strobed ID (Strob\_ID)

This output is for use in accessing the serial Strobed ID configuration information. It is retrieved by the method specified in the GLM specification.

### Strobed ID Data

Strobed ID Bit	SW	LW
D0	1	1
D1	0	1
D2	0	0
D3	1	1
D4	1	1
D5	1	1
D6	1	0
D7	1	1

### Parallel ID (Par\_ID[0:1])

These two pins tell the system logic what speed OLM is installed.

### Parallel ID Definition

Par_ID[1]	Par_ID[0]	OLM Type
0	0	132 Mbps
0	1	266 Mbps
1	0	531 Mbps
1	1	1063 Mbps

## Input Signal Definitions

Levels for the signals described in this section are listed in Digital Inputs on page 15.

### Transmit Byte Clock (TBC)

The system logic provides a single-phase Transmit Byte Clock for transmission operations. The relationship between the Transmit Data and the Transmit Byte Clock is shown in the Transmit Timing diagram below.

### Transmit Data (Tx[00:19])

Two 10-bit pre-encoded data bytes from the system logic are presented to the GLM for serialization. Byte 0, comprised of bits Tx00 through Tx09, is launched first. Byte 1, comprised of Tx10 through Tx19, is launched last. The Transmit Timing diagram below shows the setup and hold times for the Transmit Data.

## Transmit and Lock to Reference Timings

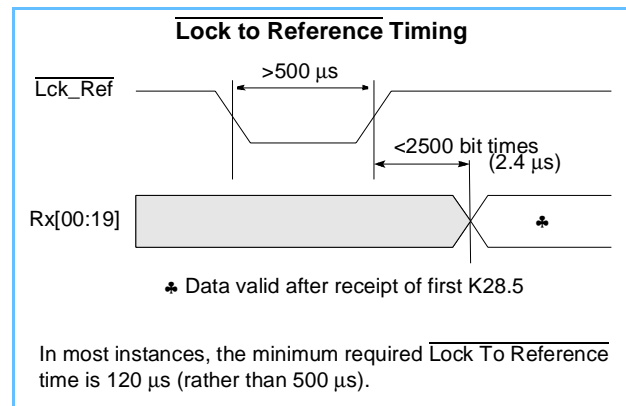
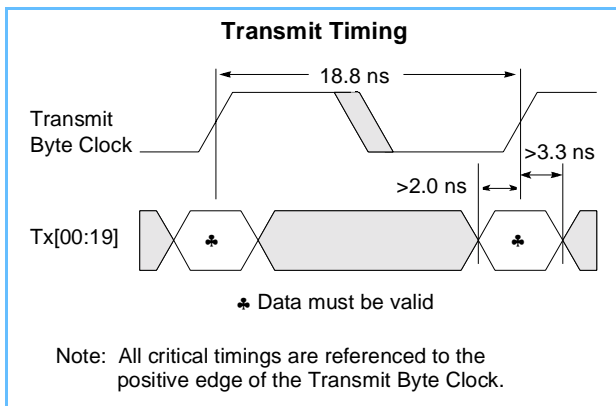

### Lock to Reference (Lck\_Ref)

This active low signal causes the deserializer PLL to acquire frequency lock on the Transmit Byte Clock (TBC). The Lock to Reference Timing diagram shows the required Lock to Reference time and the wait time for valid data.

The Lock to Reference line is used in the operation of the receiver PLL. When the incoming data stream is absent (e.g. when the companion GLM is in wrap mode), the receiver PLL will drift to a minimum or maximum frequency (27 to 106 MHz) which is far from the nominal operating point. If the incoming data is turned back on, the PLL will attempt to readjust and may lock onto either the incoming data rate *or to one of its harmonics*.

To guarantee that the PLL locks on to the fundamental frequency of the incoming data, the Lock to Reference line is driven low, forcing the PLL to lock onto the Transmit Byte Clock supplied by the system (which is extremely close to the frequency of the incoming data). It takes a maximum of 500 µs for the PLL to lock onto to the Transmit Byte Clock reference. Thereafter, the Lock to Reference line is driven high by the system and the incoming data stream is directed into the receiver PLL. The receiver PLL will achieve phase and frequency lock of the incoming data within 2500 bit times (2.4 µs).

The designer needs to be careful in choosing when the logic exercises the Lock to Reference signal. Since the receiving system is not generally in control of the incoming signal, it must make some savvy decisions about when PLL synchronization is lost.



#### Lock to Reference Timings:

The GLM specification for the minimum required Lock To Reference time is 500  $\mu$ s. Under certain conditions this minimum required time can be reduced to 120  $\mu$ s. The following paragraph describes under what conditions this reduced lock time is met.

The frequency of the receiver PLL needs to be in close proximity to the frequency of the incoming data in order to attain phase lock on the data. To do this, the Transmit Byte Clock is applied to receiver IC module through a separate pin. The Lock To Reference pin toggles whether the receiver PLL phase locks to the incoming data stream or to the Transmit Byte Clock. Whenever the Link Unusable line goes high and the Enable EWrap line is low, the receiver PLL switches to frequency lock onto the Transmit Byte Clock. When the Enable EWrap line is high, the receiver PLL stays locked to the incoming data stream even when the Link Unusable line goes high. This process achieves Lock To Reference times as short as 120  $\mu$ s.

#### **Enable Comma Detect (En\_CDdet)**

This signal activates the Comma Detect function described in Comma Detect (Com\_Det) on page 6. When this line is high, the Comma Detect line will strobe and the Receive Byte Clocks will be reset when a K28.5 character is received.

#### **Enable Wrap (EWrap)**

This signal causes the serializer to wrap the Transmit Data to the deserializer and turn off the laser within 20  $\mu$ s. As a result, the link goes down and the Link Unusable line is driven high.

This sequence causes the PLL to lose bit synchronization making it necessary to cycle the Lock to Reference line after the Link Unusable line indicates the link is active.

The wrap function on the GLM can be used to improve fault isolation. When the Enable Wrap line is driven high, the data that would normally have been transmitted on the fiber is rerouted to the receiver. The same Lock to Reference sequence used for optical data must be used to lock to the received data. When the Lock to Reference sequence is completed, the data written to the transmit data lines can be read from the Receive Data lines.

This function is useful to determine whether the GLM is correctly seated in the electrical connector. If the GLM functions correctly in wrap mode, it is likely that any fault would be in the optical path.

## Operation

### Powering On: Initial Card Outputs

- Receive Data outputs are random.
- Comma Detect will be random.
- Receive Byte Clocks will run between 27 and 106 MHz.
- Fault is low.
- Link Unusable is high.

### Ping Pong Interface Available

A shortwave 1063 Mbps GLM that utilizes a 20-bit ping ponged interface is available as a distinct IBM product. This interface is designed to reduce simultaneous switching noise. The ping-ponged interface is designed into the module and is not user selectable.

In the ping pong interface module, Tx[00:09] is timed off the rising edge of the Transmit Byte Clock as shown below. Tx[10:19] is timed off the rising edge of TBC plus one half of the TBC period using identical timing specifications as in “Transmit Data (Tx[00:19])” on page 8.

### Ping Pong Interface Timings

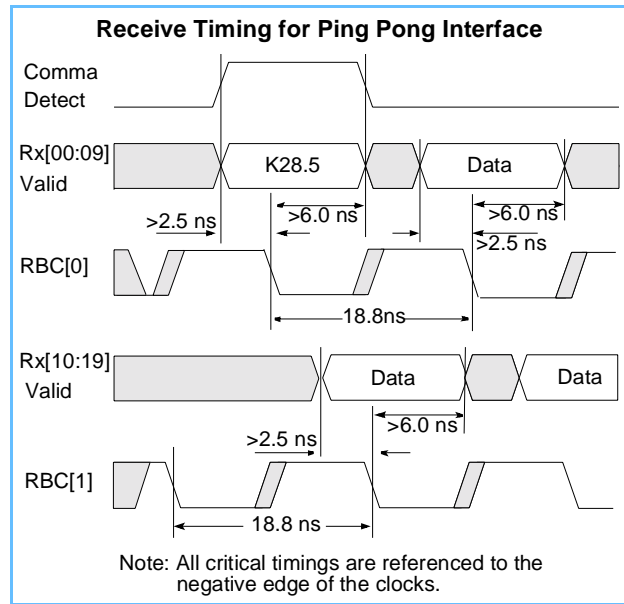
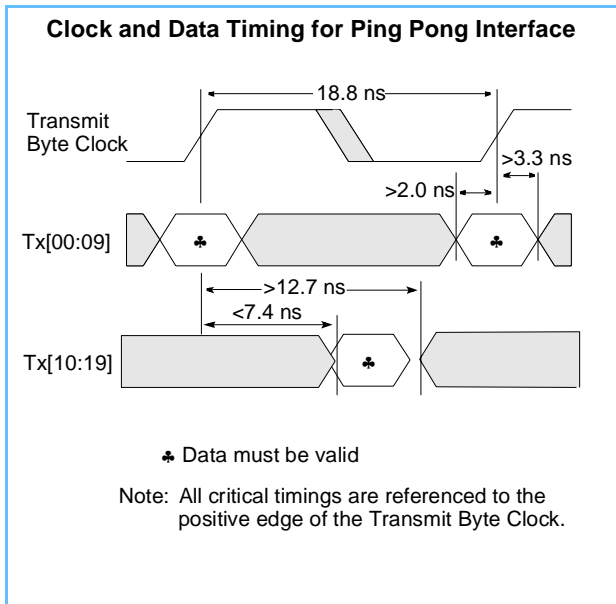

Rx[10:19] is timed off RBC[1] using identical timing specifications as in “Receive Data (Rx[00:19])” on page 5. The skew between RBC[0] and RBC[1] shall not exceed  $\pm 1.5$ ns.

## Link Acquisition Sequence

The following sequence should be followed to get a GLM in full synchronization with a companion card undergoing a similar sequence. This sequence will also work with a single card when using an optical wrap connector.

1. Power up the GLM. The Transmit Byte Clock should be running as defined in Transmit Byte Clock (TBC) on page 8.
2. The Link Unusable line will indicate if the receiver is detecting an adequate incoming light level.
3. Drive the Transmit Data lines to a 010101010101010101. (This speeds up the synchronization process and assures that the Comma Detect line will not pulse randomly on the companion card during the remainder of this sequence.)
4. Drive the input control lines as follows:
  - a. Enable Wrap: low (will not be changed)
  - b. Enable Comma Detect: high (will not be changed)
  - c. Lock to Reference: high

If a link is properly connected and the companion card is in an equivalent state of readiness, the Link Unusable line will be low. This indicates that the received light is sufficient for operation.

5. Bring Lock to Reference low for at least 500µs. See Lock to Reference (Lck\_Ref) on page 8.
6. Bring the Lock to Reference high.

After 2500 bit times (2.4 µs), the GLM should be in bit synchronization (the internal clocks are aligned to the incoming bit stream), but not yet byte synchronization (the byte is aligned along the same boundary it had when sent from the companion system to the companion GLM prior to serialization). The Receive Byte Clock frequency should now be running at 53.125 MHz (the frequency of the companion Transmit Byte Clock) and the Comma Detect line is ready to indicate reception of the Comma Character.

7. Drive the Transmit Data lines with a K28.5 (Byte Sync) character.

As soon as the GLM receives the K28.5 character from the other side of the link, the clocks will align to the byte boundary and all the Receive Data lines will have valid data. This will be indicated by the activation of the Comma Detect line (see Receive Section on page 4).

## Isolating Hardware Faults

The following sequence can be helpful in isolating most hardware faults:

1. Check the Link Unusable line. If it is low, then the link is active and this process won't help.
2. Check the Fault line. If it is high, then the laser or the laser control circuitry is faulty. Replace the GLM.  
**Note:** The Fault line is known to come on due to probing.
3. Run a set of patterns through the card while in wrap mode (see Enable Wrap (EWrap) on page 9). If these fail, run through the checks in "Troubleshooting: What If ..." below.
4. Disconnect the cable and insert an optical wrap plug, or a simplex 50-micron optical cable that works properly. Rerun the same tests you did in line 3 (not in wrap mode). If these fail, the optics are defective. Replace the GLM.
5. Rerun steps 1 to 4 on the companion GLM. If all tests pass, replace the cable.  
**Note:** If the tests in line 3 pass, this also verifies that the system and all connections to the GLM are operating correctly.  
**Note:** This sequence assumes the use of the Link Acquisition Sequence listed on page 11.

## Troubleshooting: What If ...

The module does not achieve bit synchronization:

- Verify that the transmit and receive frequencies are within 0.01% of each other.
- Verify that valid 8b/10b data is being sent on the transmit side. If the transmit side transmits a 01010101010101010101 pattern, the GLM will synchronize the clock to the data stream in the least time.

The module never gets into byte synchronization:

- Verify that the Enable Comma Detect line is high so that a Comma Character will reset the shift register.
- Verify that the transmitting GLM is getting a correct Comma Character on its Tx[00:09] or Tx[10:19] lines, but not both.  
**Note:** A common mistake is switching the order of the lines.

The Fault line comes on:

- The laser or its control circuitry is broken. Repeat the power-on sequence to verify the problem.  
**Note:** The Fault line is known to come on due to probing.



## Absolute Maximum Ratings

Parameter	Symbol	Min.	Typical	Max.	Units	Notes
Storage Temperature	$T_S$	-40		75	°C	1
Relative Humidity–Storage	$RH_S$	0		95	%	1, 2
Ambient Operating Temperature	$T_{OP}$	0		70	°C	1
Relative Humidity Operating	$RH_{OP}$	8		80	%	1, 2
Supply Voltage	$V_{CC}$	-0.5		6.0	V	1
TTL DC Input Voltage	$V_I$	0		$V_{CC} + 0.7$	V	1

1. Stresses listed may be applied one at a time without causing permanent damage. Functionality at or above the values listed is not implied. Exposure to these values for extended periods may affect reliability.
2. Excludes condensing environment.

## Operating Conditions

Parameter	Symbol	Min.	Typical	Max.	Units
Ambient Operating Temperature	$T_{OP}$	10		50	°C
Supply Voltage	$V_{CC}$	4.75	5.0	5.25	V
Relative Humidity Operating	$RH_{OP}$	8		80	%
Transmit Byte Clock	$f_{TBC}$	53.1197	53.1250	53.1303	MHz



## Electrical Characteristics

### Power Supply

Parameter	Symbol	Min.	Typical	Max.	Units
Current (@ 5.0 V)			520	600	mA
Current (@ 5.25 V)			530	620	mA
Ripple & Noise				100	mV(pk-pk)

### Digital Outputs

Parameter	Symbol	Min.	Typical	Max.	Unit	Notes
<b>Receive Byte Clock, Receive Data, Comma Detect Drive Levels</b>						
Data Output, Voltage - High (Source 0.5 mA)	$V_{OH}$	2.4		$V_{CC}$	V	
Data Output, Voltage - Low (Sink 0.5 mA)	$V_{OL}$	0		0.6	V	
<b>Receive Byte Clock, Receive Data, Comma Detect Timing</b>						
Receive Byte Clock Duty Cycle		40		60	%	
Rise Time	$t_r$	0.7	2	3.0	ns	1
Fall Time	$t_f$	0.7	2	2.4	ns	1
Receive Data Setup Time		2.5			ns	
Receive Data Hold Time		6.0			ns	
Setup Time for Data Rx[10:19] in Ping-Pong Mode		2.5			ns	2
Hold Time for Data Rx[10:19] in Ping-Pong Mode		6.0			ns	2
Unlocked Frequency		27		106	MHz	
<b>Link Unusable and Fault Driver Levels</b>						
Data Output, Voltage - High (Source 4.0 mA)	$V_{OH}$	2.4		$V_{CC}$	V	
Data Output, Voltage - Low (Sink 4.0 mA)	$V_{OL}$	0.0		0.4	V	
<b>Parallel ID Bits</b>						
Output Voltage	$V_{OH}$		$V_{CC}$		V	2

1. Rise and fall times are measured from 0.8 to 2.0 volts with the outputs driving a 10 pF lumped capacitive load.
2. See "Ping Pong Interface Available" on page 10 for a description of this timing interface.
3. The Parallel ID bits are tied to  $V_{CC}$  through 10k ohm resistors.



## Digital Inputs

Parameter	Symbol	Min.	Typical	Max.	Units	Notes
<b>Enable Wrap Level</b>						
Data Input, Voltage - High (Sink 10 $\mu$ A)	$V_{IH}$	2.0		$V_{CC}$	V	1
Data Input, Voltage - Low (Source 2 mA)	$V_{IL}$	0.0		0.8	V	1
<b>Transmit Data, Transmit Byte Clock, Enable Comma Detect, Lock to Reference, and Transmit SI Levels</b>						
Data Input, Voltage - High (Sink 10 $\mu$ A)	$V_{IH}$	2.0		$V_{CC}$	V	1
Data Input, Voltage - Low (Source 1 mA)	$V_{IL}$	0.0		0.8	V	1
<b>Transmit Byte Clock, Transmit Data Timing</b>						
Rise Time	$t_r$			3.2	ns	2
Fall Time	$t_f$			3.2	ns	2
Duty Cycle		32		68	%	
Positive Edge Jitter				0.5	ns	
Frequency	$f_{TBC}$	53.1197	53.1250	53.1303	MHz	
Transmit Data Setup Time	2.0				ns	
Transmit Data Hold Time	3.3				ns	
<p>1. The overshoot and undershoot limits for the logic inputs are 0.7 V above <math>V_{CC}</math> and ground, respectively. 2. Rise and fall times are measured from 0.8 to 2.0 volts with the outputs driving a 10 pF lumped capacitive load.</p>						



## Optical Characteristics

### Short Wavelength

Parameter	Symbol	Min.	Typical	Max.	Units	Notes
Optical Power Budget	OPB	7			dB	
<b>Receiver Specifications</b>						
Return Loss of Receiver	RL	12			dB	
Received Power		-17.0		0.0	dBm (avg)	1
Operating Wavelength	$\lambda$	770		860	nm	
<b>Transmitter Specifications</b>						
Spectral Center Wavelength	$\lambda_c$	770		860	nm	
Spectral Width	$\Delta\lambda$			4	nm (rms)	
Launched Optical Power	PT	-10.0		-5.5	dBm (avg)	2
Optical Extinction Ratio		9			dB	3
Relative Intensity Noise	RIN <sub>12</sub>			-120	dB/Hz	4
Eye Opening		57			% (pk-pk)	5
Deterministic Jitter	DJ			20	% (pk-pk)	6

1. The minimum and maximum values of the average received power in dBm give the input power range to maintain a BER < 10<sup>-12</sup>. These values take into account power penalties caused by the use of a transmitter with a worst-case combination of transmitter spectral width, extinction ratio, and pulse shape characteristics.
2. Launched optical power is measured at the end of a 2 meter section of a 50/125  $\mu$ m fiber (N.A.=0.20) for the IBM42M10SNYAA20 (short wavelength GLM) and a 9/125  $\mu$ m fiber for the IBM42M10LNYAA10 (long wavelength GLM). The maximum and minimum of the allowed range of average transmitter power coupled into the fiber are worst case values to account for manufacturing variations, drift due to temperature variations, and aging effects.
3. Extinction Ratio is the ratio of the average optical power (in dB) in a logic level one to the average optical power in a logic level zero measured under fully modulated conditions in the presence of worst case reflections.
4. RIN<sub>12</sub> is the laser noise, integrated over a specified bandwidth, measured relative to average optical power with 12 dB return loss. See ANSI Fibre Channel Specification Annex A.5 [1].
5. Eye opening is the portion of the bit time which is error free for a given bit error rate (BER). The Fibre Channel standard for BER is < 10<sup>-12</sup>. The general laser transmitter pulse shape characteristics are specified in the form of a mask of the transmitter eye diagram. These characteristics include rise time, fall time, pulse overshoot, pulse undershoot, and ringing, all of which should be controlled to prevent excessive degradation of the receiver sensitivity. When assessing the transmit signal, it is important to consider not only the eye opening, but also the overshoot and undershoot limitations.
6. Deterministic Jitter is measured as the peak-to-peak timing variation of the 50% optical signal crossings when transmitting repetitive K28.5 characters. It is defined in FC-PH, version 4.1, clause 3.1.84 as:

*Timing distortions caused by normal circuit effects in the transmission system. Deterministic jitter is often subdivided into duty cycle distortion (DCD) caused by propagation differences between the two transitions of a signal and data dependent jitter (DDJ) caused by the interaction of the limited bandwidth of the transmission system components and the symbol sequence.*



## Long Wavelength

Parameter	Symbol	Min.	Typical	Max.	Units	Notes
Optical Power Budget	OPB	9			dB	7
<b>Receiver Specifications</b>						
Return Loss of Receiver	RL	12			dB	
Received Power		-20.0		-3.0	dBm(avg)	1
Operating Wavelength	$\lambda$	1270		1355	nm	
<b>Transmitter Specifications</b>						
Spectral Center Wavelength	$\lambda_C$	1270		1355	nm	
Spectral Width	$\Delta\lambda$			6	nm (RMS)	
Launched Optical Power	PT	-9.0		-3.0	dBm (avg)	2
Optical Extinction Ratio		9			dB	3
Relative Intensity Noise	$RIN_{12}$			-116	dB/Hz	4
Eye Opening		57			% (pk-pk)	5
Deterministic Jitter	DJ			20	% (pk-pk)	6

- The minimum and maximum values of the average received power in dBm give the input power range to maintain a BER <math>10^{-12}</math>. These values take into account power penalties caused by the use of a transmitter with a worst-case combination of transmitter spectral, extinction ratio, and pulse shape characteristics.
- Launched optical power is measured at the end of a 2 meter section of a 50/125  $\mu\text{m}$  fiber (N.A.=0.20) for the IBM42M10SNYAA20 (short wavelength GLM) and a 9/125 mm fiber for the IBM42M10LNYAA10 (long wavelength GLM). The maximum and minimum of the allowed range of average transmitter power coupled into the fiber are worst case values to account for manufacturing variations, drift due to temperature variations, and aging effects.
- Extinction Ratio is the value of the ratio of the average optical power (in dB) in a logic level one to the average optical power in a logic level zero measured under fully modulated conditions in the presence of worst case reflections.
- $RIN_{12}$  is the laser noise, integrated over a specified bandwidth, measured relative to average optical power with 12 dB return loss. See ANSI Fibre Channel Specification Annex A.5 [1].
- Eye opening is the portion of the bit time which is error free for a given bit error rate (BER). The Fibre Channel standard for BER is <math>10^{-12}</math>. The general laser transmitter pulse shape characteristics are specified in the form of a mask of the transmitter eye diagram. These characteristics include rise time, fall time, pulse overshoot, pulse undershoot, and ringing, all of which should be controlled to prevent excessive degradation of the receiver sensitivity. For the purpose of an assessment of the transmit signal, it is important to consider not only the eye opening, but also the overshoot and undershoot limitations.
- Deterministic Jitter is measured as the peak-to-peak timing variation of the 50% optical signal crossings when transmitting repetitive K28.5 characters. It is defined in FC-PH, version 4.1, clause 3.1.84 as:  
*Timing distortions caused by normal circuit effects in the transmission system. Deterministic jitter is often subdivided into duty cycle distortion (DCD) caused by propagation differences between the two transitions of a signal and data dependent jitter (DDJ) caused by the interaction of the limited bandwidth of the transmission system components and the symbol sequence.*
- This 9dB optical power budget is a result of the difference between the worst case transmitted launch power, the receiver sensitivity and a 2 dB optical path power penalty (as specified in the ANSI Fibre Channel specification):  

$$(-9 \text{ dBm}) - (-20 \text{ dBm} + 2 \text{ dB}) = 9 \text{ dB}$$



## Optical Cable/Connector Requirements

Parameter	Symbol	Min.	Typical	Max.	Units	Notes
<b>9/125 <math>\mu</math>m Cable and Connector Specifications (Single mode)</b>						
Length	L	2		10000	m	
Attenuation @ 1300 nm	$\mu_c$			0.5	dB/km	
<b>SC Optical Connector (Single Mode)</b>						
Nominal Attenuation	$\mu_{con}$		0.75			1
Attenuation Standard Deviation	$\sigma_{con}$		0.2			1
Connects/Disconnects				250	cycles	1
<b>50/125 <math>\mu</math>m Cable and Connector Specifications (Multimode)</b>						
Length	L	2		550	m	
Bandwidth @ 850 nm	BW	500			MHz-km	
Attenuation @ 850 nm	$\mu_c$			3.0	dB/km	
Numerical Aperture	N.A.		0.20			
<b>62.5/125 <math>\mu</math>m Cable Specifications (Multimode)</b>						
Length		2		300	m	
Bandwidth @ 850 nm	BW	160			MHz-km	
Attenuation @ 850 nm				3.0	dB/km	
Numerical Aperture	N.A.		0.275			
<b>SC Optical Connector (Multimode)</b>						
Nominal Attenuation	$\mu_{con}$		0.3	0.5	dB	1
Attenuation Standard Deviation	$\sigma_{con}$		0.2		dB	1
Connects/Disconnects				250	cycles	1
1. The optical interface connector dimensionally conforms to the industry standard SC type connector documented in JIS-5973. A dual keyed SC receptacle serves to align the optical transmission fiber mechanically to the GLM. See "Duplex SC Receptacle" on page 22 for a drawing of the duplex SC receptacle that is part of the GLM.						



## Thermal Characteristics

Air Speed (lfpm)	External Thermal Resistance ( $R_{ext}$ ) (°C/W)	Notes
<b>Ser/Des IC Module</b>		
161	25.9	1
268	20.9	1
375	18.0	1
<b>Laser Driver/Post Amp IC Module</b>		
161	51.2	1
268	43.2	1
375	38.7	1

1. The case temperature can be calculated using the following equation:

$$CASE = T_{ambient} + R_{ext} \times ACF \times Power$$

where  $ACF$  = Altitude Correction Factor (1 for Sea Level & 1.12 for 4200 ft.) and  $Power$  = power dissipated in the serializer or deserializer IC module (calculated from table below).

$V_{CC} = 4.75\text{ V to }5.25\text{ V}$

IC Module	Typical	Max
Serializer/Des.	0.92W	1.32W
Laser Driver/Post Amp	0.65W	0.84W

## Reliability Projections

Parameter	Symbol	Min	Typical	Max.	Units	Notes
Average Failure Rate	AFR			0.0195	%/khr	1

1. AFR specified over 44 khours. To meet the specified AFR, the case temperatures of the serializer and deserializer IC modules should not exceed 85°C. In addition, the case temperature of the laser should not exceed 50°C.

## Mechanical Description

### Card Layout

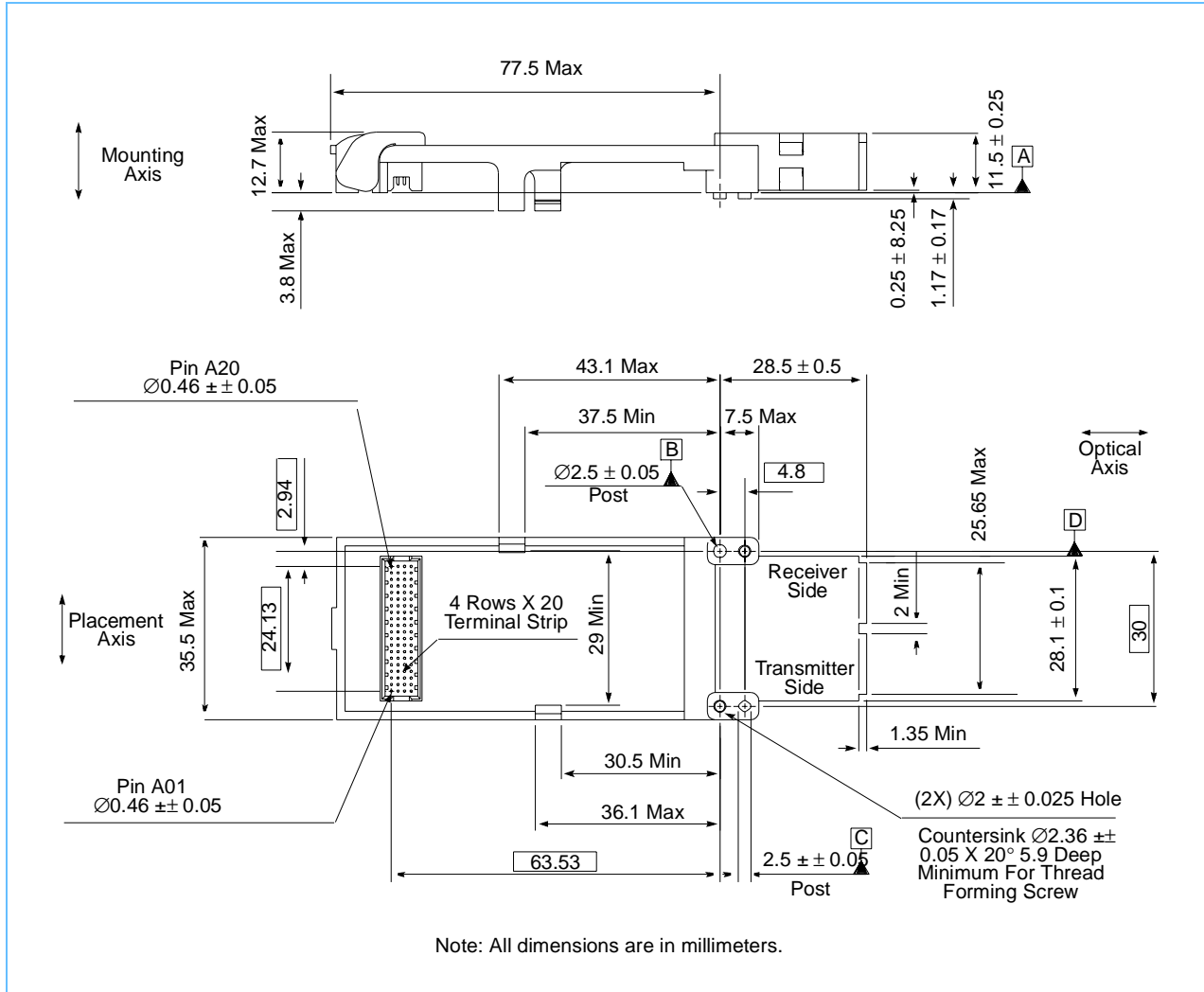

The transmit and receive circuits are electrically isolated on opposite sides of a double sided surface mount card. Two optical receptacles are at the end of the card. They are spaced 12.7 mm apart to accept a standard duplex SC connector such as the one shown on page 22.

The optical receptacles on the end of the IBM42M10LNYAA10 (long wavelength GLM) do not contain the Fibre Channel specified "single mode keying" features. Both singlemode and multimode SC duplex connectors can be inserted.

The Host Card Footprint with essential keepout areas is shown on page 21.



### System Board Thickness

These GLMs are optimized for use with a board that is between 0.053 inches (1.35 mm) and 0.073 inches (1.85 mm) thick. Thicker boards can be used by:

- Routing out the area where the L-Clip latches into the board so that it does not exceed a thickness of 0.073 inches.
- Routing out a larger area than required by the L-Clips and using some other retention mechanism (e.g. the screw holes on the optical end of the card).

### Duplex SC Receptacle

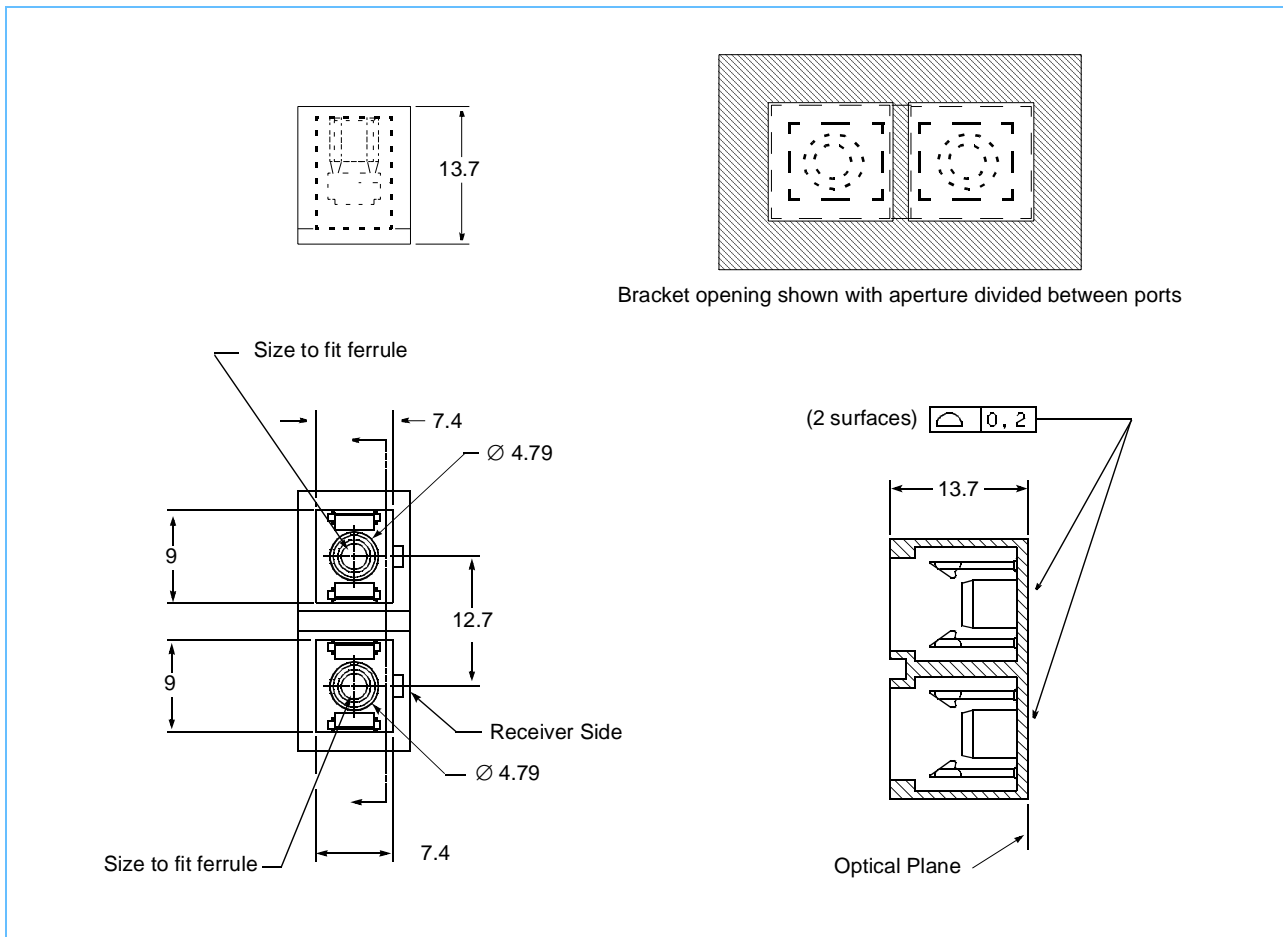

## System Board Configurations

These GLMs are designed to be used in multiple configurations:

- **Back-to-back:** All necessary card features are offset to allow ease of installation on opposite sides of a host card. This requires the use of female surface mount connectors on the system card.
- **Close pitch side-to-side:** Cards can be placed on a 36.8 mm pitch by sharing common holes for L-Clip retention.
- **Both:** Back-to-back and close pitch side-to-side are completely compatible.

## Mechanical Features

**Positive Retention:** The integrated L-Clips provide sufficient retention for most environments. Screw holes are integrated into the retainer on the optical end of the product for use in environments with high vibration content or where tail stock or other additional mounting hardware is not used to secure the SC connectors.

**Integrated Extraction Tool:** This tool provides a simple method to remove the GLM from the host card without requiring access to the sides or back of the card. It also minimizes stress to both the GLM and the system card during removal of the GLM.

**Alignment Pins:** These pins are integrated into the product. The center of the round pin is the GDT (Geometrical Dimension and Tolerance, an industry standard mechanical drawing methodology) registration point. These pins also provide stress relief for the 80-pin connector. This is especially important when the system card uses a surface mount connector.

**EMI Slot:** There is a small (2 mm) vertical slot in the SC connector. This allows the system to cut the aperture of SC connector in half. This is extremely important in applications where the SC connector extends outside the system box. We strongly encourage designing the tail stock with a hole for each of the SC connectors (i.e., have a small metal strip between the connectors).

## Connector Availability

One source for the mating connectors is:

Samtec  
810 Progress Blvd., PO Box 1147  
New Albany, IN 47151-1147  
(812) 944-6733

Samtec Part Numbers:  
Pin-in-hole: FOLC-120-01-P-Q-LC  
Surface-mount with Standard Clipping:  
    FOLC-120-02-P-Q-LC  
Surface-mount with Reverse Clipping:  
    FOLC-120-02-P-Q-LCR

## References

1. American National Standards Institute Inc. (ANSI), X3T11, Fibre Channel-Physical and Signaling Interface (FC-PH). Copies of this document may be purchased from:  

Global Engineering  
15 Inverness Way East  
Englewood, CO 80112-5704  
Phone: (800) 854-7179 or (303) 792-2181  
Fax: (303) 792-2192.
2. Fibre Channel Systems Initiative. (FCSI), Gigabaud Link Module Family FCSI-301-Revision1.0, Feb. 16, 1994. This document may be downloaded under anonymous ftp from: playground.sun.com. It is in the file pub/incoming/fcsi-301-rev1.ps
3. A.X. Widmer and P.A. Franaszek, "A DC-Balanced, Partitioned-Block, 8B/10B Transmission Code," *IBM Journal of Research and Development*, vol. 27, no. 5, pp. 440-451, September 1983. This paper fully defines the 8b/10b code. It is primarily a theoretical work pinned in coding theory.
4. A.X. Widmer, The ANSI Fibre Channel Transmission Code, *IBM Research Report, RC 18855 (82405)*, April, 23 1993. Copies may be requested from:  

Publications  
IBM Thomas J. Watson Research Center  
Post Office Box 218  
Yorktown Heights, New York 10598  
Phone: (914) 945-1259  
Fax: (914) 945-4144



## Revision Log

Rev. Date	Contents of Modification
11/09/98	Initial release (00).
3/22/99	First revision (01). Corrected maximum wavelength to 10km. Corrected part numbers to end in -10 instead of -20.
11/10/99	Second revision (02). On page 3, added Laser Safety Compliance Requirements and corrected 780nm to 850nm in Ordering Information table. Deleted notes 2 and 3 from Optical Cable/Connector Requirements on page 18.
11/29/00	Third revision (03). Adjusted fault time on page 7. Changed voltage from 5.5 to 5.25 for second Current entry in the Power Supply table on page 14. Changed Resistance and $V_{CC}$ values in the Thermal Characteristics table on page 19. Changed abbreviations for megabits per second from Mb/s and Mbit/s to Mbps. Changed abbreviation for megabytes per second from Mbytes/s to MBps. Used a blank space before every unit of measure. Changed capitalization of 8B/10B to 8b/10b (to more clearly show that the "b" stands for "bit"), except in title of published article.



© International Business Machines Corporation 1999

All Rights Reserved  
Printed in the United States of America November 2000

The following are trademarks of International Business Machines Corporation in the United States, or other countries, or both.

IBM            IBM Logo

Other company, product and service names may be trademarks or service marks of others.

All information contained in this document is subject to change without notice. The products described in this document are NOT intended for use in implantation or other life support applications where malfunction may result in injury or death to persons. The information contained in this document does not affect or change IBM product specifications or warranties. Nothing in this document shall operate as an express or implied license or indemnity under the intellectual property rights of IBM or third parties. All information contained in this document was obtained in specific environments, and is presented as an illustration. The results obtained in other operating environments may vary.

THE INFORMATION CONTAINED IN THIS DOCUMENT IS PROVIDED ON AN "AS IS" BASIS. In no event will IBM be liable for damages arising directly or indirectly from any use of the information contained in this document.

IBM Microelectronics Division  
1580 Route 52, Bldg. 504  
Hopewell Junction,  
NY 12533-6351

The IBM home page can be found at  
<http://www.ibm.com>

The IBM Microelectronics Division home page  
can be found at <http://www.chips.ibm.com>

GLM1063N.03  
November 29, 2000