

### 4-Bit Binary Counter

The 41DL(M) and 41EC(L) devices are bipolar, NPN, sealed junction, silicon integrated circuits. They are available in 16-pin plastic DIPs. The circuit contains a divide-by-two counter and a 3-bit quinary counter.

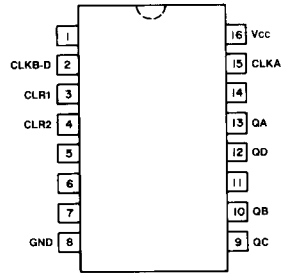

### Truth Tables

Count Sequence*				
Count	Outputs			
	Qd	Qc	Qb	QA
0	L	L	L	L
1	L	L	L	H
2	L	L	H	L
3	L	L	H	H
4	L	H	L	L
5	L	H	L	H
6	L	H	H	L
7	L	H	H	H
8	H	L	L	L
9	H	L	L	H
10	L	L	L	L
11	H	L	H	H
12	H	H	L	L
13	H	H	L	H
14	H	H	H	L
15	H	H	H	H
16	L	L	L	L

Clear/Count					
Inputs		Outputs			
Clear 1	Clear 2	Qd	Qc	Qb	QA
H	H	L	L	L	L
X	L	Count			
L	X	Count			

\* The circuit counts on the negative transition of CLOCK A and output QA is connected to CLOCK B.

H = High Level  
 L = Low Level  
 X = Irrelevant

# 41DL(M), 41EC(L)

## Logic Diagram

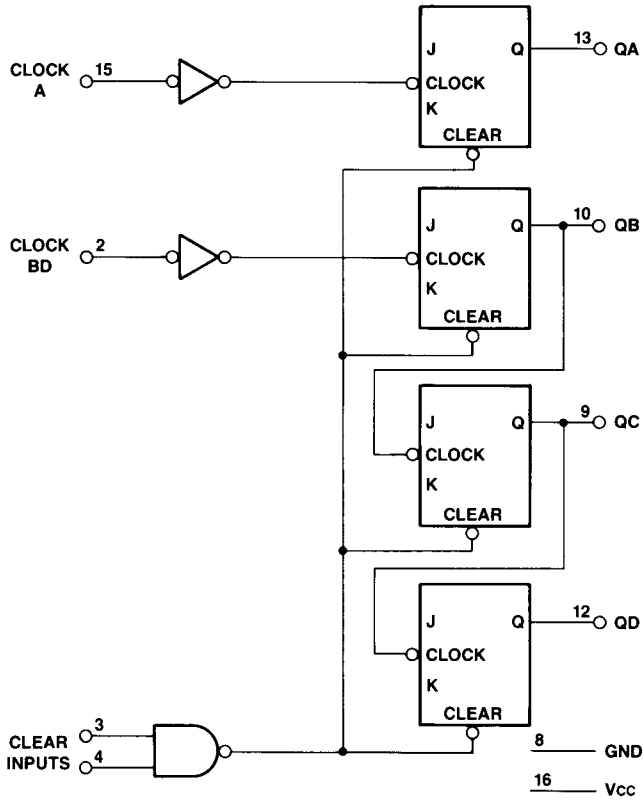

**Electrical Characteristics**

V<sub>CC</sub> = 5.0 ±0.5 V, T<sub>J</sub> = 0 to 85 °C

Parameter	Symbol	Test Conditions	MTTL Family			LTTL Family			Unit
			41DL Device			41EC Device			
			Min	Typ	Max	Min	Typ	Max	
Output Voltage									
High	V <sub>OH</sub>	V <sub>CC</sub> =4.5 V, I <sub>OH</sub> =-4.0 mA	2.4	3.5	—	—	—	—	V
High	V <sub>OH</sub>	V <sub>CC</sub> =4.5 V, I <sub>OH</sub> =-0.4 mA	—	—	—	2.4	3.5	—	V
Low	V <sub>OL</sub>	V <sub>CC</sub> =4.5 V, I <sub>OL</sub> =9.8 mA	—	0.25	0.4	—	—	—	V
Low	V <sub>OL</sub>	V <sub>CC</sub> =4.5 V, I <sub>OL</sub> =2.4 mA	—	—	—	—	0.25	0.4	V
Input Voltage									
High	V <sub>IH</sub>	—	1.8	—	—	1.8	—	—	V
Low	V <sub>IL</sub>	—	—	—	0.8	—	—	0.8	V
Clamp	V <sub>IK</sub>	I <sub>IK</sub> = -5 mA	—	—	-1.5	—	—	-1.5	V
Input Current									
High, V <sub>IH</sub> =2.4 V	I <sub>IH</sub>	V <sub>CC</sub> =5.5 V	—	—	40	—	—	10	μA
High, V <sub>IH</sub> =5.5 V	I <sub>IH</sub>	V <sub>CC</sub> =5.5 V	—	—	200	—	—	100	μA
Low	I <sub>IL</sub>	V <sub>CC</sub> =5.5 V, V <sub>IL</sub> =0.4 V	—	—	-0.98	—	—	-0.24	mA
Output Current									
Short-Circuit	I <sub>OS</sub>	V <sub>CC</sub> =5.5 V, V <sub>OL</sub> =0.0 V	-20	—	-75	-5	—	-30	mA
Power Supply Current	I <sub>CC</sub>	V <sub>CC</sub> =5.5 V	—	—	40	—	—	10	mA

**Timing Characteristics**

V<sub>CC</sub>=5.0 V, T<sub>J</sub>=25 °C

Parameter	MTTL Family			LTTL Family			Unit
	41DL Device			41EC Device			
	Min	Typ	Max	Min	Typ	Max	
Input Clock Frequency (f <sub>C</sub> max)	20	—	—	5	—	—	MHz
Pulse Width							
Clock (t <sub>θw</sub> )	25	—	—	100	—	—	ns
Clear (t <sub>w</sub> )	40	—	—	100	—	—	ns
Propagation Delays							
Clock A to Q <sub>A</sub>							
t <sub>PHL</sub>	—	—	32	—	—	100	ns
t <sub>PLH</sub>	—	—	26	—	—	95	ns
Clock B <sub>D</sub> to Q <sub>B</sub>							
t <sub>PHL</sub>	—	—	32	—	—	100	ns
t <sub>PLH</sub>	—	—	26	—	—	95	ns
Clock B <sub>D</sub> to Q <sub>C</sub>							
t <sub>PHL</sub>	—	—	55	—	—	170	ns
t <sub>PLH</sub>	—	—	50	—	—	150	ns
Clock B <sub>D</sub> to Q <sub>D</sub>							
t <sub>PHL</sub>	—	—	65	—	—	210	ns
t <sub>PLH</sub>	—	—	65	—	—	210	ns
Clear to Q							
t <sub>PHL</sub>	—	—	40	—	—	105	ns
Transition Times							
t <sub>THL</sub>	—	—	15	—	—	25	ns
t <sub>TLH</sub>	—	—	20	—	—	150	ns

**Maximum Ratings**

Power supply voltage (V <sub>CC</sub> )	7.0 V
Input voltage (V <sub>I</sub> )	5.5 V
Operating temperature range (T <sub>J</sub> )	-25 to +125 °C
Storage temperature range (T <sub>stg</sub> )	-40 to +125 °C

Maximum ratings are defined as the limiting conditions that the user can apply to the device under all variations of circuit and environmental conditions. If any rating is exceeded, permanent damage to the device may result.

Bonding or soldering of the external leads of this device can be performed safely at temperatures up to 300 °C.