

SMB3105-0316

SMB Plug Crimp For Bulkhead 50Ω

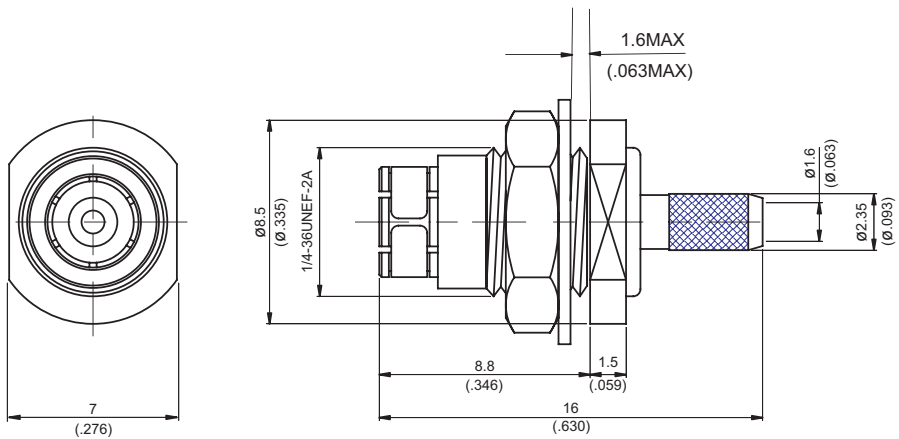

MOUNTING HOLE :

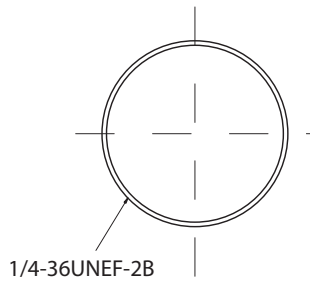

Parts	Material	Plating (Micro-inch)
Contact Pin	Phosphor Bronze	Gold 20 Over Nickel 50 Over Copper 50
Insulator	Teflon	
Body	Brass	Gold 5 Over Nickel 50 Over Copper 50

Weight:

Suitable Cables: RG174, RG188, RG316, JBY100, RG316-E, RG316-FEP

This part number complies with RoHS.

Notice: JYEBAO reserves the right to make modifications deemed appropriate.

## CABLE ASSEMBLY INSTRUCTION

SMB3105-0316

JYE BAO CO., LTD.

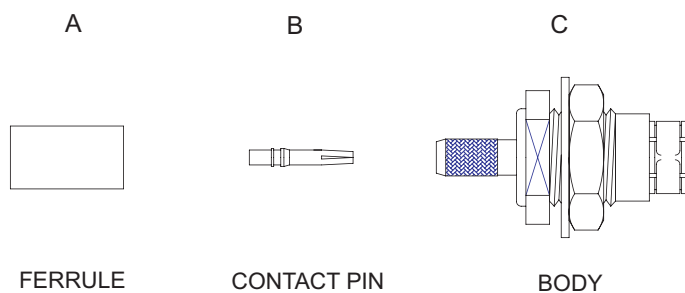

DIAGRAM	ASSEMBLY INSTRUCTION
	Step 1: STRIP AS SHOWN.
	Step 2: SLIDE FERRULE "A" OVER CABLE. Step 3: PUT PIN "B" ON CENTER CONDUCTOR AND CRIMP IN "Y".
	Step 4: LOOSEN BRAIDING AND SLIDE CONNECTOR "C" IN PLACE.
	Step 5: SLIDE FERRULE "A" TOWARDS THE CONNECTOR AND CRIMP.

This part number complies with RoHS.

Notice: JYEBAO reserves the right to make modifications deemed appropriate.