

Power Factor Controller IC for High Power Factor and Active Harmonic Filter

TDA 4814
TDA 4816

Bipolar IC

Features

- IC for sinusoidal line-current consumption
- Power factor approaching 1
- Controls boost converter as an active harmonics filter
- Direct drive of SIPMOS transistor
- Zero crossing detector for discontinuous operation mode with variable frequency
- 110/220 V AC operation without switchover
- Standby current consumption of 0.5 mA
- Start/stop monitoring circuit for lamp generators

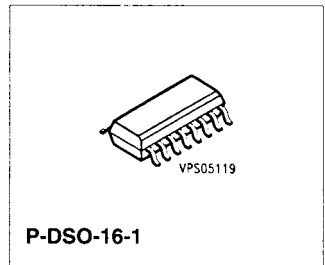
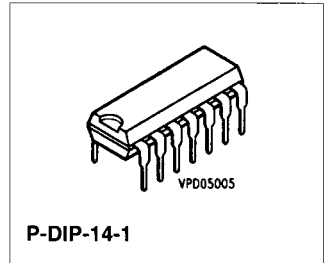

	Type	Ordering Code	Package
S	TDA 4814 A	Q67000-A8163	P-DIP-14-1
S	TDA 4816 G	Q67000-A8290	P-DSO-16-1 (SMD)

TDA 4814 A

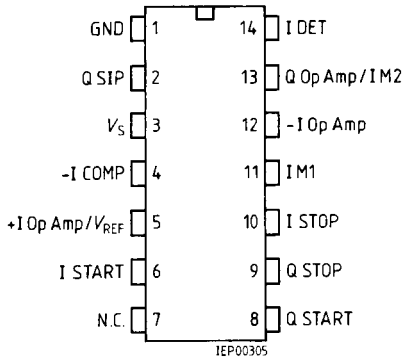

TDA 4816 G

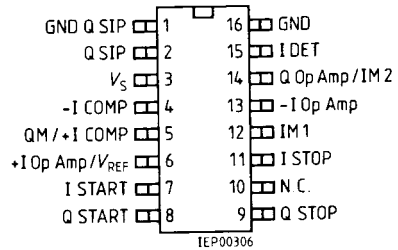

Pin Configurations (top view)

Pin Definitions and Functions

Pin		Symbol	Function
P-DIP-14	P-DSO-16		
	1	GND QSIP	Driver Ground
1		GND	Ground
2	2	QSIP	Driver output
3	3	V_S	Supply voltage
4	4	- ICOMP	Negative comparator input
	5	QM/+ICOMP	Multiplier output/positive comparator input
5	6	+I OP Amp/ V_{REF}	Positive input/reference voltage
6	7	I START	Start input
7	10	N.C.	Not connected
8	8	Q START	Start output
9	9	Q STOP	Stop output
10	11	I STOP	Stop input
11	12	I M1	Multiplier input M1
12	13	- I OP Amp	Negative input OP amplifier
13	14	QOP Amp/I M2	Op amplifier output and multiplier input M2
14	15	I DET	Detector input
	16	GND	Ground 0 V

The TDA 4814 A and TDA 4816 G contain all functions for designing electronic ballasts and switched-mode power supplies with sinusoidal line current consumption and a power factor approaching 1.

They control a boost converter as an active harmonic filter in a discontinuous (triangular shaped current) mode with variable frequency.

The output voltage of this filter is regulated with high efficiency. Therefore the device can easily be operated on different line voltages (110/220 V_{AC}) without any switchover.

The on-chip start/stop circuit monitors the lamp generator of electronic ballasts. It starts a self-oscillating lamp generator and shuts it down in the event of malfunction, e.g. if the lamp is defective.

A typical application is in electronic ballasts, especially when a large number of such lamps are concentrated on one line supply point.

With the TDA 4816 G the features of the TDA 4814 A have been extended.

The multiplier output was bonded out to facilitate fixed-frequency operation with an additional PWM-IC.

Besides that a separate driver ground (GND QSIP) is implemented.

The TDA 4816 G comes in a P-DSO-16 package, the TDA 4814 A in a P-DIP-14 package.

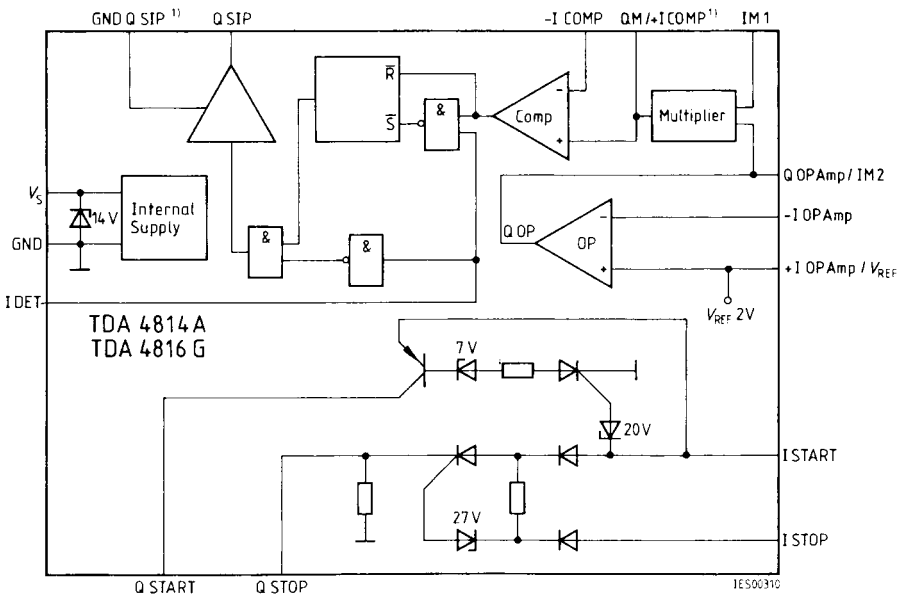

Block Diagram

Circuit Description

This device has a conditioning circuit for the internal power supply. It allows standby operation with very low current consumption (less than 0.5 mA), a hysteresis between enable and switch-off levels and an internal voltage stabilization. An integrated Z-diode limits the voltage on V_s , when impressed current is fed.

The **output driver (Q SIP)** is controlled by detector input and current comparator.

The **detector input (I DET)** which is highly resistive in the operating state reacts on hysteresis-determined voltage levels. To keep down the amount of circuitry required, clamping diodes are provided which allow control by a current source.

The operating state of the boost converter choke is sensed via the detector input. H-level means that the choke discharges and the output driver is inhibited. H-level sets a flip-flop, which stores the switch-off instruction of the current comparator to reduce susceptibility to interference. As soon as demagnetization is finished the choke voltage reverses and the detector input is set to L-level, thus enabling the output driver. This ensures that the choke is always currentless when the SIPMOS transistor switches on and that no current gaps appear.

The nominal voltage of the multiplier output is compared to the voltage derived from the actual line current (**- I COMP**), thus setting the switch-off threshold of the comparator. The current comparator blocks the output driver when the nominal peak value of the choke current given by the multiplier output is reached.

This state is maintained in the flip-flop until H-level appears at detector input which takes over the hold function and resets the flip-flop.

Operating states might occur without any useful detector signal. This is the case with magnetic saturation of the choke and when the input voltage approaches or exceeds the output voltage as, for example, during switch-on. The driver remains inhibited for the flip-flop due to the absent set signal.

The trigger signal can be derived from the subsequent lamp generator, a SMPS control device or, if neither one of them is available, from the start circuit designed as a pulse generator in the TDA 4814. The trigger signal level should be so low that with standard operation the signal from the detector winding dominates.

The multiplier delivers the preset nominal value for the current comparator by multiplying the input voltage, which determines the nominal waveform (**IM1**) and the output voltage of the control amplifier.

The control amplifier stabilizes the output dc voltage of the active harmonic filter in the event of load and input voltage changes. The **control amplifier** compares the actual output voltage to a reference voltage which is provided in the IC and stable with temperature.

Output Driver

The output driver is intended to drive a SiPMOS transistor directly. It is designed as a push-pull stage.

Both the capacitive input impedance and keeping the gate level at zero potential in standby operation by an internal 10-k Ω -resistor are taken into account. Possible effects on the output driver by line inductances or capacitive couplings via SiPMOS transistor Miller capacitance are limited by diodes connected to ground and supply voltage.

Ground Pins

Between the ground pins GND and GND QSIP, a very close and low-impedance connection is to be established.

Monitoring Circuit (I START, I STOP, Q START, Q STOP)

The monitoring circuit guarantees the secure operation of subsequent circuitries.

Any circuitry that is shut down because of a fault, for instance, cannot be started up again until the **monitoring start (I START / Q START)** has turned on and a positive voltage pulse has been impressed on Q START. This function starts for example the lamp generator of an electronic ballast or generates auxiliary trigger signals for the detector input.

If there is a defect present (e.g. defective fluorescent lamp) the **monitoring stop (I STOP / Q STOP)** will shut down either the entire unit or simply the circuitry that has to be protected. No restart is possible then until the hold current impressed on I START or Q STOP has been interrupted (e.g. by a power down).

Absolute Maximum Ratings

$T_A = -40$ to 125 °C

Parameter	Symbol	Limit Values		Unit	Notes
		min.	max.		
Supply voltage	V_S	-0.3	V_Z	V	$V_Z = Z$ Voltage

Inputs

Comparator	$V_{I\text{COMP}}$	-0.3	33	V	-
	$V_{-I\text{COMP}}$	-0.3	33	V	-
Op Amp	$V_{I\text{Op Amp}}$	-0.3	6	V	-
	$V_{-I\text{Op Amp}}$	-0.3	6	V	-
Multiplier	V_{M1}	-0.3	33	V	-

Outputs

Multiplier	V_{QM}	-0.3	3	V	$V_S > 3$ V
Op Amp	$V_{O\text{Op Amp}} / I_{M2}$	-0.3	6	V	-
Z current V_S GND	I_Z	0	300	mA	Observe P_{max}
Driver output QSIP	V_{QSIP}	-0.3	V_S	V	Observe P_{max}
QSIP clamping diodes	$I_{QSIP\ D}$	-10	10	mA	$V_O > V_S$ or $V_O < -0.3$ V
Input START	$V_{I\text{START}}$	-0.3	25	V	see characteristics see characteristics
	$V_{I\text{STOP}}$	-0.3	33	V	
Output START	$V_{O\text{START}}$	-10	3	V	-
	$V_{O\text{STOP}}$	-0.3	6	V	-
Detector input	$V_{I\text{DET}}$	0.9	6	V	-
Detector clamping diodes	$I_{I\text{DET}}$	-10	10	mA	$V_{I\text{DET}} > 6$ V or $V_{I\text{DET}} < 0.9$ V
Capacitance at I START to ground	$C_{I\text{START}}$	-	150	nF	-
Junction temperature	T_j	-	150	°C	-
Storage temperature	T_{stg}	-55	125	°C	-
Thermal resistance system - air	P-DIP-14 $R_{\text{th SA}}$	-	65	K/W	-
	P-DSO-16-1 $R_{\text{th SA}}$	-	100	K/W	-

Absolute Maximum Ratings (cont'd)

$T_A = -40$ to 125 °C

Parameter	Symbol	Limit Values		Unit	Notes
		min.	max.		

Operating Range

Supply voltage	V_S	$V_{S\ ON}$	V_Z	V	Values for $V_{S\ ON}$, V_Z : see characteristics
Z-current	I_Z	0	200	mA	Observe P_{max}
Driver current	$I_{O\ OSIP}$	-500	500	mA	-
Operating temperature	T_A	-25	85	°C	-

Characteristics

$V_{S\ ON}^{1)} < V_S < V_Z$; $T_A = -25$ to 85 °C

Parameter	Symbol	Limit Values			Unit
		min.	typ.	max.	

Current Consumption

Without load on driver QSIP and V_{REF} ; QSIP LOW $0\ V < V_S < V_{S\ ON}$ $V_{S\ ON} < V_S < V_Z$	I_S	-	-	0.5	mA
Load on QD with SIPMOS gate; dynamic operation 50 kHz $V_S = 12\ V$ load on Q = 10 nF	I_S	2.5	5	6.5	mA
	I_S	-	-	15	mA

Hysteresis on V_S

Turn-ON threshold for V_S rising	V_{SH}	9.6	10.4	11.2	V
Switching hysteresis	V_{Shy}	1.0	-	1.7	V

Comparator (COMP)

Input offset voltage	V_{IO}	-10	-	10	mV
Input current	$-I_I$	-	-	2	µA
Common-mode input voltage range	V_{IC}	0	-	3.5	V

Characteristics (cont'd)

$V_{S\text{ON}}^{1)} < V_S < V_Z$; $T_A = -25$ to 85 °C

Parameter	Symbol	Limit Values			Unit
		min.	typ.	max.	

Operational Amplifier (Op Amp)

Open-loop voltage gain	G_{V0}	60	80	–	dB
Input offset voltage	V_{IO}	–30	–	–10	mV
Input current	$-I_I$	–	–	2	μA
Common-mode input voltage range	V_{IC}	0	–	3.5	V
Output current	$I_{O\text{ Op Amp}}$	–3	–	1.5	mA
Output voltage	$V_{O\text{ Op Amp}}$	1.2	–	4	V
Transition frequency	f_T	–	2	–	MHz
Transition phase	Φ_T	–	120	–	deg.

Output Driver (QSIP)

Output voltage high	V_{QH}	5	–	–	V
$I_O = -10$ mA	–	–	–	–	–
Output voltage low	V_{QL}	–	–	1	V
$I_O = +10$ mA	–	–	–	–	–
Output current	–	–	–	–	–
rising edge $C_L = 10$ nF	$-I_Q$	200	300	400	mA
falling edge $C_L = 10$ nF	I_Q	250	350	450	mA

Reference-Voltage Source

Voltage	V_{REF}	1.9	2	2.1	V
$0 < I_{REF} < 3$ mA	–	–	–	–	–
Load current	$-I_L$	0	–	3	mA
Voltage change	ΔV_{REF}	–	–	5	mV
10 V $< V_S < V_Z$	–	–	–	–	–
Voltage change	ΔV_{REF}	–	–	20	mV
0 mA $< I_{REF} < 3$ mA	–	–	–	–	–
Temperature response	$\Delta V_{REF} / \Delta T$	–0.3	–	0.3	mV/K

Z-Diode ($V_S - \text{GND}$)

Z-voltage	V_Z	13	15.5	17	V
$I_Z = 200$ mA	–	–	–	–	–
Observe P_{max}	–	–	–	–	–

Characteristics (cont'd)

$V_{S\ ON}^{1)} < V_S < V_Z$; $T_A = -25$ to $85\ ^\circ\text{C}$

Parameter	Symbol	Limit Values			Unit
		min.	typ.	max.	
Multiplier (M1) ²⁾					
Quadrant for input voltages	—	—	1	—	qu.
Input voltage M1	V_{M1}	0	—	1	V
Reference level for M1	$V_{REF\ M1}$	—	0	—	V
Input voltage M2	V_{M2}	V_{REF}	—	$V_{REF} + 1$	V
Reference level for M2	$V_{REF\ M2}$	—	V_{REF}	—	V
Input current M1, M2	$-I_I$	0	—	2	μA
Coefficient for output-voltage source	C_Q	0.4	0.6	0.8	I / V
Max. output voltage	$V_{QM\ max}$	—	1.6	—	V
Output resistance	R_Q	—	5	—	k Ω
Temperature response of output-voltage coefficient	$\Delta TC / C_Q$	-0.3	-0.1	0.1	% / K

Monitoring Circuit

Input I START					
Turn-ON voltage	$V_{I\ ON\ START}$	17	22	26	V
Turn-ON current	$I_{I\ ON\ START}$	50	90	130	μA
Turn-OFF voltage	$V_{I\ OFF\ START}$	2	3.5	5	V
Turn-OFF current	$I_{I\ OFF\ START}$	70	110	150	μA
Input I STOP *					
Turn-ON voltage	$V_{I\ ON\ STOP}$	27	30	33	V
Turn-ON current	$I_{I\ ON\ STOP}$	100	150	200	μA
Turn-OFF voltage	$V_{I\ OFF\ STOP}$	4.5	6.5	8.5	V
Turn-OFF current	$I_{I\ OFF\ STOP}$	175	250	320	μA
Transfer I START - Q START					
Output current on Q START					
$V_{START} = 15\ \text{V};$ $V_{Q\ START} = 2\ \text{V}$	$-I_{Q\ START}$	400	600	800	mA
Transfer I STOP - Q STOP					
Output current on Q STOP					
$I_{STOP} = 1.5\ \text{mA};$ $V_{STOP} = 18\ \text{V};$ $V_{Q\ STOP} = 1.2\ \text{V};$ $I_{STOP} = 0.4\ \text{mA};$ $V_{STOP} = 7\ \text{V};$ $V_{STOP} = 1.2\ \text{V};$	$-I_{Q\ STOP}$	0.9	1.2	—	mA
	$-I_{Q\ STOP}$	60	150	—	μA

*) The turn-ON voltage of I_{STOP} exceeds the turn-on voltage of I_{START} by at least 3 V.

Characteristics (cont'd)

$V_{S\text{ON}}^{1)} < V_S < V_Z$; $T_A = -25$ to 85 °C

Parameter	Symbol	Limit Values			Unit
		min.	typ.	max.	

Detector (I DET)

Upper switching voltage for voltage rising (H)	$V_{\text{DET H}}$	1	1.3	1.6	V
Lower switching voltage for voltage falling (L)	$V_{\text{DET L}}$	0.95	—	—	V
Switching hysteresis	$V_{\text{S hy}}$	50	—	300	mV
Input current	$-I_{\text{DET}}$	—	5	10	μA
Clamping-diode current	I_{DET}	—3	—	3	mA
$0.9\text{ V} < V_{\text{DET}} < 6\text{ V}$ $V_{\text{DET}} > 6\text{ V}$ or $V_{\text{DET}} < 0.9\text{ V}$					

Delay Times

Input comparator QSIP ³⁾	t	—	200	500	ns
-------------------------------------	-----	---	-----	-----	----

1) $V_{S\text{ON}}$ means that V_{SH} has been exceeded but that the voltage is still greater than $(V_{\text{SH}} - V_{\text{S hy}})$.

2) Calculation of the output voltage V_{OM} : $V_{\text{OM}} = C \times V_{\text{M1}} \times V_{\text{M2}}$ in V.

3) Step functions at comparator input $\Delta V_{\text{COMP}} = -100\text{ mV} \rightarrow \Delta V_{\text{COMP}} = +100\text{ mV}$.

4

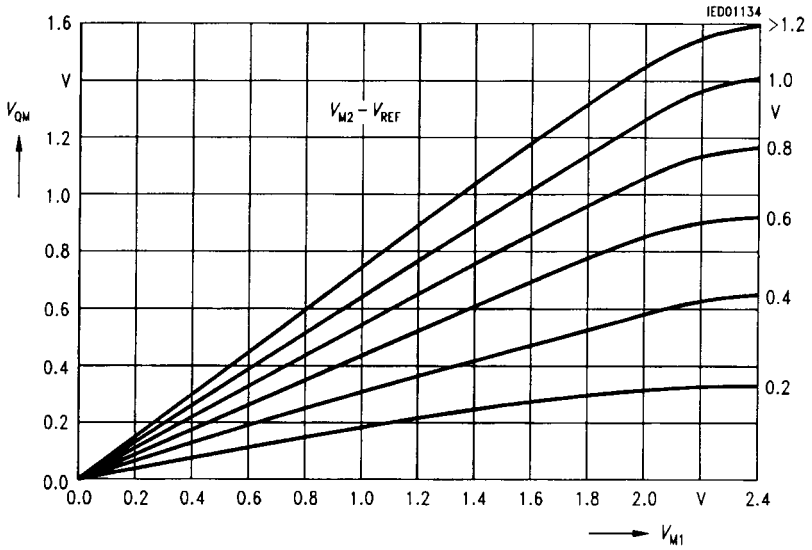

Multiplier Characteristics

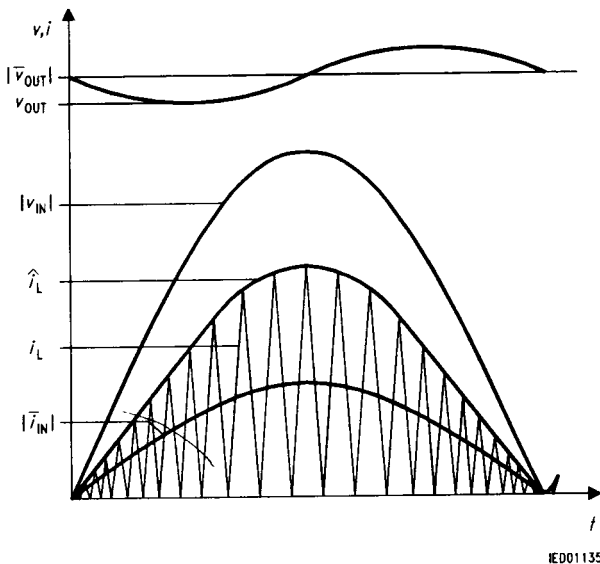

Discontinuous Operation Mode with Variable Frequency

The TDA 4814 A and TDA 4816 G work in a discontinuous operation mode with variable frequency.

The principle of a freely oscillating controller exploits the physical relationship between current and voltage at the boost converter choke. The current in the semiconductors flows in a triangular shape. It is only when the current in the boost converter diode has gone to zero that the transistor goes conductive. This arrangement does away with the diode's power-squandering reverse currents.

If triangular currents flow continuously through the boost converter choke the input current averaged over a high-frequency period is exactly half the peak of the high-frequency choke current.

If the peak values of the choke current are located along an envelope curve that is proportional to a sinusoidal, low-frequency input voltage, the input current available after smoothing in an RFI filter is sinusoidal.

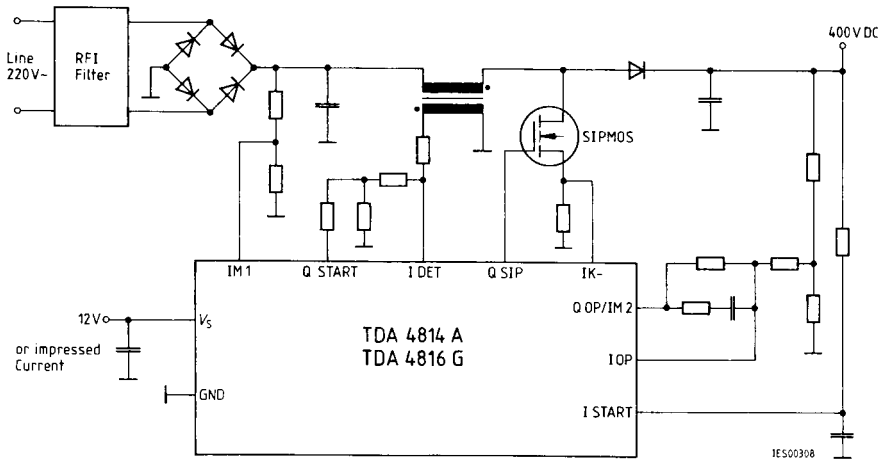

Typical Application Circuit Boost Converter with TDA 4814 A / 4816 G

The TDA 4814A and TDA 4816G control a boost converter as an active harmonic filter, drawing a sinusoidal line current and providing a regulated DC voltage at the converter output.

The active harmonic filter improves the power factor in electronic ballasts for fluorescent lamps and in switched-mode power supplies, reducing the harmonic content of the incoming, non rectified mains current and if suitably dimensioned permitting operation at input voltages between 90 V and 270 V.

Benefits of TDA 4814 A and TDA 4816 G in Electronic Ballasts and SMPS

- Sinusoidal line current consumption
- Power Factor approaching 1 increases the power available from the AC line by more than 35 % compared to conventional rectifier circuits. Circuit breakers and connectors become more reliable because of the lower peak currents.
- Active harmonic filtering reduces harmonic content in line current to meet VDE / IEC / EN-standards.
- Wide-range power supplies are easier to implement for AC input voltages of 90 to 250 V without switchover.
- Preregulated DC output voltage provides optimal operating conditions for a subsequent converter.
- Reduced smoothing capacitance:
For a given amplitude of the 100 / 120 Hz ripple voltage the smoothing capacitance can be reduced by 50 % in comparison to a conventional rectifier circuit.
- Reduced choke size:
Rectifier circuits capable of more than 200 W usually employ chokes to decrease the charging current of the capacitor. These chokes are larger than those used in a preregulator with power-factor control.
- Higher efficiency:
A preregulator does cause some additional losses, but these are more than compensated for by the cut in losses created by the rectifier configuration and the optimum operating conditions that are produced for a subsequent converter, even in the event of supply-voltage fluctuations.

Summary of Effects of DC-Voltage Preregulation with Power-Factor Control

Parameter	Conventional Power Rectification	Power Rectification with Preregulator and Power-Factor Control
Mean DC supply voltage	280 V	340 V
Maximum DC supply voltage with line overvoltage	350 V	350 V
Minimum DC supply voltage with line undervoltage	230 V	330 V
Relative reverse voltage of diodes with line overvoltage	1	0.7
Relative forward resistance of SIPMOS transistors with sustained conducting-state power loss and line undervoltage	1	2.06
Relative forward resistance of SIPMOS transistors with sustained conducting-state power loss and rated supply voltage	1	1.74
Relative input capacitance with sustained ripple voltage	1	0.3 to 0.5
Power factor	0.5 to 0.7	0.99