

# SN55500E AC PLASMA DISPLAY DRIVER

D2471, DECEMBER 1984—REVISED MAY 1990

- Controls 32 Electrodes
- 100-V Totem-Pole Outputs
- Low Stand-by Power Consumption
- All Outputs Contain Sink and Source Clamp Diodes
- 15 mA Steady-State Output Current
- Rugged DMOS Outputs
- CMOS Inputs
- Dependable Texas Instruments Quality and Reliability
- Direct Replacement for SN55500D

## description

The SN55500E is a monolithic BIFET<sup>†</sup> integrated circuit designed to perform the line select operation of a matrix-addressable display. The device inputs are diode-clamped CMOS inputs.

The outputs of the driver are normally low and can be selectively switched high when the strobe input is low. Selection of the outputs is achieved through the data, S0, and S1 inputs. The 8-bit data stored internally in the serial register is inverted and sent to one of four output sections by the 2-line to 4-line decoder. All other outputs remain low. Internal circuits provide a high-current pulse to the level-shifting circuit during positive output transitions. When the output transition is complete, the low steady-state current reduces the circuits standby power consumption. All outputs contain clamp diodes to the VCC2 and GND supply inputs.

The SN55500E is characterized for operation over the full military temperature range of -55°C to 125°C.

## JD PACKAGE (TOP VIEW)

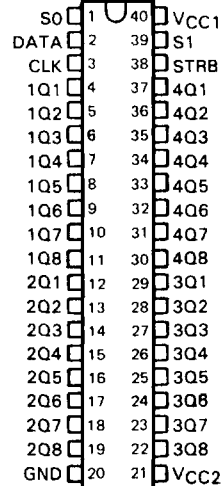

## FD PACKAGE (TOP VIEW)

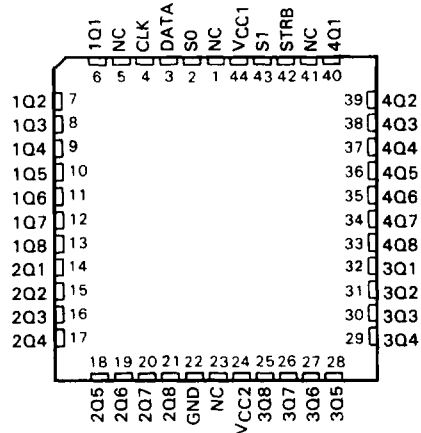

NC—No internal connection

<sup>†</sup> BIFET—Bipolar, double-diffused, N-channel and P-channel MOS transistors on same chip—patented process.

PRODUCTION DATA documents contain information current as of publication date. Products conform to specifications per the terms of Texas Instruments standard warranty. Production processing does not necessarily include testing of all parameters.

**TEXAS  
INSTRUMENTS**

POST OFFICE BOX 655303 • DALLAS, TEXAS 75265

Copyright © 1990, Texas Instruments Incorporated

# SN55500E AC PLASMA DISPLAY DRIVER

logic symbol†

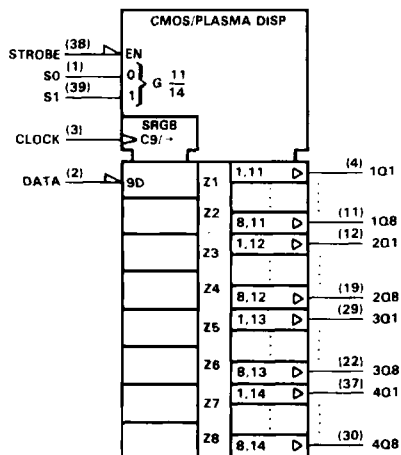

functional block diagram (positive logic)

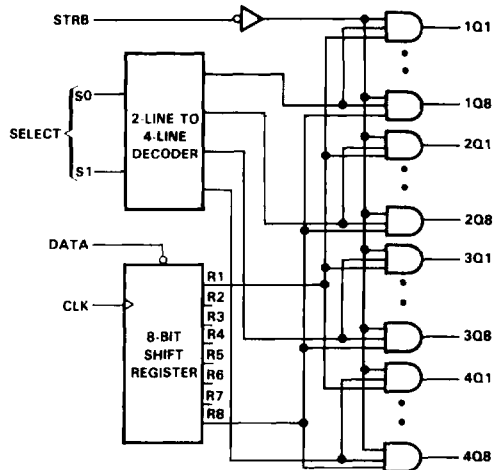

† This symbol is in accordance with ANSI/IEEE Std 91-1984 and IEC Publication 617-12.

Pin numbers shown are for the JD package.

FUNCTION TABLE

FUNCTION	INPUTS					OUTPUTS							
	DATA	CLK	SELECT S1 S0		STRB	SHIFT REGISTER							
						R1	R2	R3 ... R8	1Q1 ... 1Q8	2Q1 ... 2Q8	3Q1 ... 3Q8	4Q1 ... 4Q8	
LOAD	H	↑	X	X	H	L	R1 <sub>n</sub>	R2 <sub>n</sub> ... R7 <sub>n</sub>	L ... L	L ... L	L ... L	L ... L	
	L	↑	X	X	H	H	R1 <sub>n</sub>	R2 <sub>n</sub> ... R7 <sub>n</sub>	L ... L	L ... L	L ... L	L ... L	
STROBE	X	X	X	X	H	R1 <sub>n</sub>	R2 <sub>n</sub>	R3 <sub>n</sub> ... R8 <sub>n</sub>	L ... L	L ... L	L ... L	L ... L	
	X	H	L	L	L	R1 <sub>n</sub>	R2 <sub>n</sub>	R3 <sub>n</sub> ... R8 <sub>n</sub>	R1 ... R8	L ... L	L ... L	L ... L	
	X	H	L	H	L	R1 <sub>n</sub>	R2 <sub>n</sub>	R3 <sub>n</sub> ... R8 <sub>n</sub>	L ... L	R1 ... R8	L ... L	L ... L	
	X	H	H	L	L	R1 <sub>n</sub>	R2 <sub>n</sub>	R3 <sub>n</sub> ... R8 <sub>n</sub>	L ... L	L ... L	R1 ... R8	L ... L	
	X	H	H	H	L	R1 <sub>n</sub>	R2 <sub>n</sub>	R3 <sub>n</sub> ... R8 <sub>n</sub>	L ... L	L ... L	L ... L	R1 ... R8	

H = high level, L = low level, X = irrelevant, ↑ = low-to-high transition.

R1 ... R8 = levels currently at internal outputs of shift registers one through eight, respectively.

R1<sub>n</sub> ... R8<sub>n</sub> = levels at outputs R1 through R8 respectively, before the most recent ↑ transition of the clock.

typical operating sequence

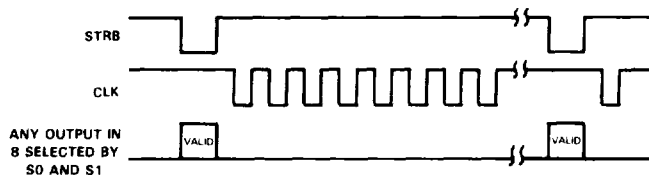

**schematics of inputs and outputs**

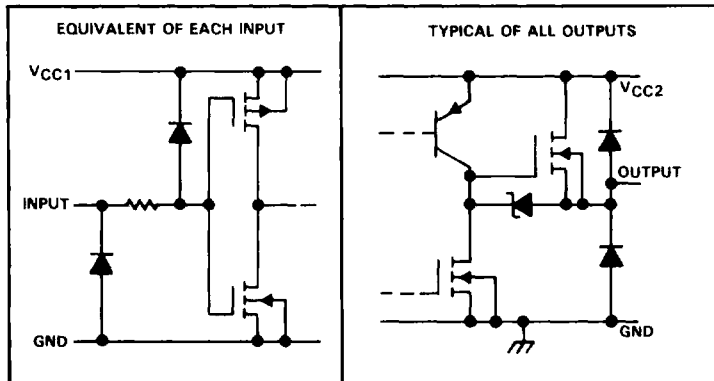

**absolute maximum ratings over operating free-air temperature range (unless otherwise noted)**

Supply voltage, VCC1 (see Note 1)	13.8 V
Supply voltage, VCC2	100 V
Input voltage	VCC1 + 0.3 V
Continuous total dissipation at (or below) 25°C free-air temperature (see Note 2)	1825 mW
Operating free-air temperature range	-55°C to 125°C
Storage temperature range	-65°C to 150°C
Case temperature for 60 seconds: FD package	260°C
Lead temperature 1,6 mm (1/16 inch) from case for 60 seconds: JD package	300°C

- NOTES: 1. Voltage values are with respect to network ground terminal.  
2. For operation above 25°C free-air temperature, see Dissipation Rating Table.

**DISSIPATION RATING TABLE**

PACKAGE	POWER RATING	DERATING FACTOR	ABOVE T <sub>A</sub>
FD	1825 mW	14.6 mW/°C	25°C
JD	1825 mW	22 mW/°C	67°C

# SN55500E

## AC PLASMA DISPLAY DRIVER

### recommended operating conditions

		MIN	NOM	MAX	UNIT
Supply voltage, $V_{CC1}$		10.8	12	13.2	V
Supply voltage, $V_{CC2}$		0		100	V
High-level input voltage, $V_{IH}$ , as a percentage of $V_{CC1}$		75%			
Low-level input voltage, $V_{IL}$ , as a percentage of $V_{CC1}$				25%	
High-level output clamp current				20	mA
Low-level output clamp current				-20	mA
Clock frequency, $f_{clock}$ (see Figure 2)		0		8	MHz
Duration of high or low clock pulse, $t_w$		62			ns
Setup time, $t_{SU}$	Data inputs before clock <sup>†</sup>	20			ns
	Select inputs before strobe <sup>‡</sup>	50			
Hold time, $t_H$	Data inputs after clock <sup>†</sup> (see Note 3)	50			ns
	Strobe input high after clock <sup>†</sup>	50			
	Select inputs after strobe <sup>‡</sup>	50			
Operating free-air temperature, $T_A$		-55			°C
Operating case temperature, $T_C$				125	°C

NOTE 3: For operation above 25°C junction temperature, refer to Figure 2.

### electrical characteristics over recommended operating temperature range (unless otherwise noted)

PARAMETER	TEST CONDITIONS	MIN	TYP <sup>†</sup>	MAX	UNIT
$V_{IK}$ Input clamp voltage	$V_{CC1} = 12\text{ V}$ , $I_I = -12\text{ mA}$		-1	-1.5	V
$V_{OH}$ High-level output voltage	$V_{CC1} = 13.2\text{ V}$ , $V_{CC2} = 100\text{ V}$	$I_{OH} = -1\text{ mA}$	94	97.5	V
		$I_{OH} = -10\text{ mA}$	92	94.5	
		$I_{OH} = -15\text{ mA}$	90	93.5	
$V_{OL}$ Low-level output voltage	$V_{CC1} = 13.2\text{ V}$ , $V_{CC2} = 100\text{ V}$	$I_{OL} = 1\text{ mA}$	0.85	2	V
		$I_{OL} = 10\text{ mA}$	2	4	
		$I_{OL} = 15\text{ mA}$	2.75	5	
$V_{OK}$ Output clamp voltage	$V_{CC2} = 0$	$I_O = 20\text{ mA}$	1	2.5	V
		$I_O = -20\text{ mA}$	-1.2	-2.5	
$I_{IH}$ High-level input current	$V_{CC1} = 13.2\text{ V}$ , $V_I = V_{IH}\text{ min}$			1	$\mu\text{A}$
$I_{IL}$ Low-level input current	$V_{CC1} = 13.2\text{ V}$ , $V_I = V_{IL}\text{ max}$			-1	$\mu\text{A}$
$I_{CC1}$ Supply current	$V_{CC1} = 13.2\text{ V}$ , $V_{CC2} = 100\text{ V}$		0.05	1	mA
$I_{CC2}$ Supply current	$V_{CC2} = 100\text{ V}$		1	5	mA

<sup>†</sup>All typical values are at  $V_{CC} = 12\text{ V}$ ,  $T_A = 25^\circ\text{C}$ .

### switching characteristics, $V_{CC1} = 12\text{ V}$ , $V_{CC2} = 100\text{ V}$ , $T_A = 25^\circ\text{C}$

PARAMETER	TEST CONDITIONS	MIN	MAX	UNIT
$t_{DHL}$ Delay time, high-to-low-level output from strobe input	$C_L = 30\text{ pF}$ , See Figure 1		250	ns
$t_{DLH}$ Delay time, low-to-high-level output from strobe input			450	ns
$t_{THL}$ Transition time, high-to-low-level output			200	ns
$t_{TLH}$ Transition time, low-to-high-level output			300	ns

TEXAS  
INSTRUMENTS

POST OFFICE BOX 855303 • DALLAS, TEXAS 75265

PARAMETER MEASUREMENT INFORMATION

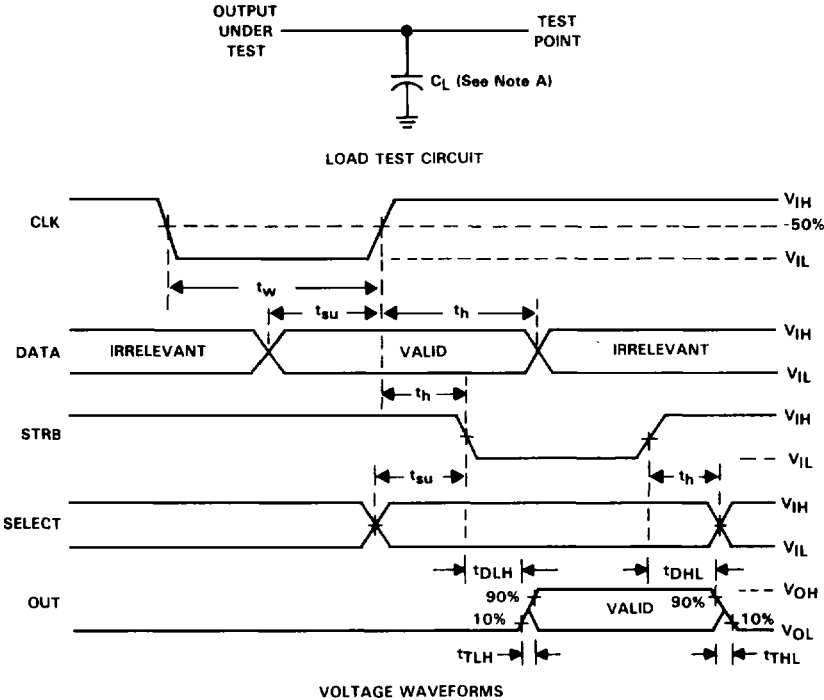

NOTE A.  $C_L$  includes probe and jig capacitance.

FIGURE 1. SWITCHING CHARACTERISTICS



POST OFFICE BOX 855303 • DALLAS, TEXAS 75285

**TYPICAL CHARACTERISTICS**

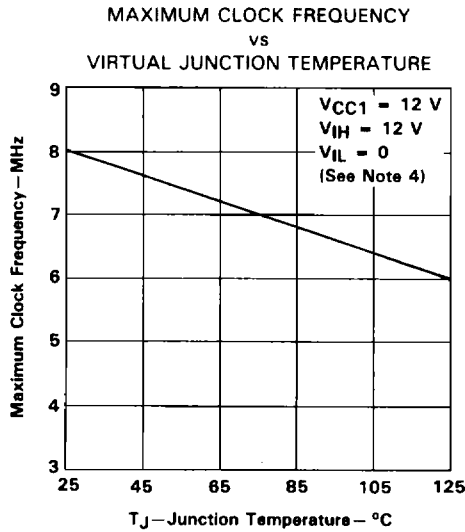

NOTE 4: This curve assumes a symmetrical clock pulse.

**FIGURE 2**

**THERMAL INFORMATION**

junction temperature formula

$$T_J = T_A + P_D R_{\theta JA}$$

$$T_J = T_C + P_D R_{\theta JC}$$

where

T<sub>J</sub> = virtual junction temperature

T<sub>A</sub> = free-air temperature

P<sub>D</sub> = average device power dissipation

R<sub>θ</sub> = thermal resistance (junction-to-air, R<sub>θJA</sub>, or junction-to-case, R<sub>θJC</sub>)

PACKAGE TYPE	R <sub>θJA</sub>	R <sub>θJC</sub>
FD 44-pin ceramic	88°C/W	20°C/W
JD 40-pin ceramic	45°C/W	12°C/W