



Features

- 667 Mb/s port data bandwidth, >85Gb/s aggregate bandwidth
- Low power CMOS, 2.5V and 3.3V power supply
- SRAM-based, in-system programmable
- 256 configurable I/O ports
 - 128 dedicated differential input ports
 - 128 dedicated differential output ports
 - Supports LVDS and LVPECL I/O
 - LVTTTL control interface
 - Output Enable control for all outputs
- Non-blocking switch matrix
 - Patented ActiveArray™ for superior performance
 - Double-buffered configuration RAM cells for simultaneous global updates
 - ImpliedDisconnect™ for single cycle disconnect/connect
- Full Broadcast and multicast capability
 - One-to-One and One-to-Many connections
 - Special broadcast mode routes one input to all outputs at maximum data rate
- Registered and flow-through data modes
 - 333 MHz synchronous mode
 - 667 Mb/s asynchronous mode
 - Low jitter and signal skew
 - Low duty cycle distortion
- RapidConfigure™ parallel interface for configuration and readback
- JTAG serial interface for configuration and Boundary Scan testing
- 792 TBGA package with 1.00mm ball spacing

Description

The OCX™ family of SRAM-based devices are non-blocking $n \times n$ digital crosspoint switches capable of data rates of 667 Megabits per second per port. The I/O ports are fixed as either input or output ports. The input ports support flow-through mode only. The output ports are individually programmable to operate in either flow-through (asynchronous) or registered (synchronous) mode. Each output register may be clocked by a global clock or a next neighbor clock source.

The patented ActiveArray provides greater density, superior performance, and greater flexibility compared to a traditional $n:1$ multiplexer architecture. The OCX devices support various operating modes covering one input to one output at a time as well as one input to many outputs, plus a special broadcast mode to program one input to all outputs while maintaining maximum data rates. In all modes data integrity and connections are maintained on all unchanged data paths.

The RapidConfigure parallel interface allows fast configuration of both the Output Buffers and the switch matrix. Readback is supported for device test and verification purposes. The OCX256 also supports the industry standard JTAG (IEEE 1149.1) interface for boundary scan testing. The JTAG interface can also be used to download configuration data to the device and readback data. A functional block diagram of the OCX256 is shown in Figure 1.

Applications

- SONET/SDH and DWDM
- System Backplanes and Interconnects
- ATM Switch Cores
- Digital Cross-Connects
- High Speed Test Equipment
- Video Switching

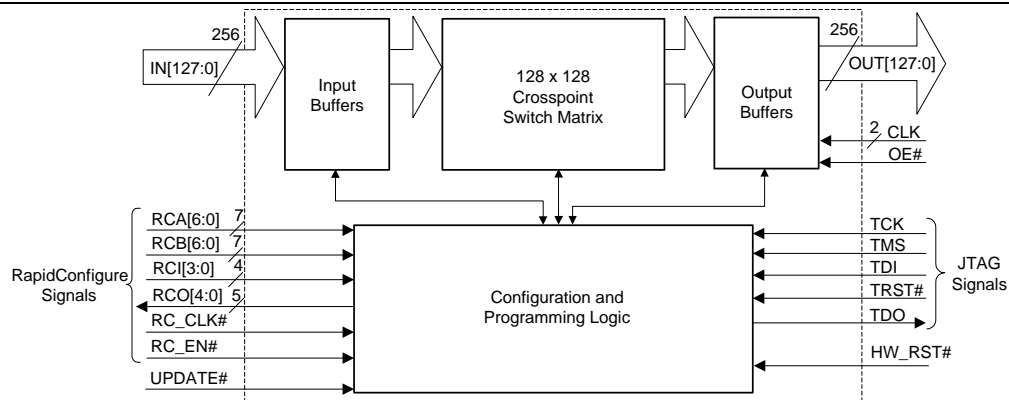

Figure 1 OCX256 Functional Block Diagram



(This page intentionally left blank)



Contents

- 1. Introduction 7**
 - 1.1 Input and Output Buffers 8
 - 1.1.1 Input and Output Port Function Mode 8
 - 1.1.2 Broadcast Mode 9
 - 1.2 Output Buffer Configuration 9
 - 1.2.1 Output Control Signals..... 9
 - 1.2.2 Neighboring Output Port as a Clock Source 9
 - 1.3 RapidConfigure Interface 11
 - 1.3.1 RapidConfigure Programming Instructions..... 11
 - 1.3.2 ImpliedDisconnect 13
 - 1.4 JTAG Configuration Controller..... 14
 - 1.4.1 JTAG Interface..... 14
 - 1.4.2 Output Port Configuration 14
 - 1.4.3 Switch Matrix Configuration 14
 - 1.4.4 Mode Control Register Configuration..... 14
 - 1.4.5 JTAG Architecture and Shift Registers 15
 - 1.4.6 JTAG State Machine 16
 - 1.4.7 JTAG Input Format 16
 - 1.4.8 JTAG Instructions 17
 - 1.5 Device Reset Options 20
- 2. Pin Description21**
- 3. Differential I/O Standards22**
 - 3.1 LVDS 22
 - 3.2 LVPECL..... 23
 - 3.3 Termination Resistor Packs 24
 - 3.4 Mixed I/O Systems..... 24
- 4. Electrical Specifications25**
 - 4.1 Absolute Maximum Ratings 25
 - 4.2 Recommended Operating Conditions 25



4.3 Pin Capacitance 25

4.4 DC Electrical Specifications..... 26

4.5 AC Electrical Specifications..... 27

4.6 Timing Diagrams..... 28

5. Package and Pinout 32

5.1 Package Pinout 32

5.2 Pinout by Ball Sequence..... 33

5.3 Pinout by Ball Name 37

5.4 Package Dimensions..... 41

5.5 Package Thermal Characteristics..... 43

6. Power Consumption 44

6.1 Power for LVDS I/O 44

6.2 Power for LVPECL I/O 45

7. Component Availability and Ordering Information 46

8. Glossary 46

9. Product Status Definition 48



Figures

Figure 1	OCX256 Functional Block Diagram	1
Figure 2	OCX256 Switch Matrix	7
Figure 3	Input and Output Buffer Configuration	8
Figure 4	Next Neighbor Clock Block Diagram	10
Figure 5	OCX256 JTAG Architecture	15
Figure 6	OCX256 JTAG State Machine	16
Figure 7	Transmitting LVDS Signal Circuit	22
Figure 8	Receiving LVDS Signal Circuit	22
Figure 9	Transmitting LVPECL Signal Circuit	23
Figure 10	Receiving LVPECL Signal Circuit.....	23
Figure 11	Registered Output Mode Timing	28
Figure 12	Flow-Through Mode Timing	28
Figure 13	Output Enable Timing	28
Figure 14	Duty Cycle Distortion	29
Figure 15	RapidConfigure Write Cycle	29
Figure 16	RapidConfigure Read Cycle	30
Figure 17	JTAG Timing.....	30
Figure 18	Typical Performance LVDS mode	31
Figure 19	Typical Performance LVPECL mode.....	31
Figure 20	OCX256 Package Pinout	32
Figure 21	OCX256 Package—Bottom View	41
Figure 22	OCX256 Package—Top and Side Views	42
Figure 23	Power Consumption Diagram for the OCX256 using LVDS.....	44
Figure 24	Power Consumption Diagram for the OCX256 using LVPECL.....	45



Tables

Table 1	Summary for Programmable I/O Attributes for OCX256.....	8
Table 2	Next Neighbor Outputs.....	10
Table 3	RapidConfigure Programming Instructions	11
Table 4	RCO[4:0] Readback Pin Assignment.....	13
Table 5	Programming an Output Buffer using RapidConfigure	13
Table 6	Mode Control Register	14
Table 7	JTAG Input Format	16
Table 8	JTAG Instructions	17
Table 9	Programming an Output using JTAG.....	19
Table 10	Number of JTAG Cycles and Configuration Time	19
Table 11	Device Reset Options	20
Table 12	OCX256 Pin Description.....	21
Table 13	Termination Resistor Packs.....	24
Table 14	Supply Voltages and Terminating Resistors	24
Table 15	Absolute Maximum Ratings.....	25
Table 16	Recommended Operating Conditions.....	25
Table 17	Pin Capacitance	25
Table 18	LVTTL DC Electrical Specifications.....	26
Table 19	LVDS DC Electrical Specifications	26
Table 20	LVPECL DC Electrical Specifications	26
Table 21	AC Electrical Specifications.....	27
Table 22	OCX256 Pinout By Ball Sequence.....	33
Table 23	OCX256 Pinout By Ball Name	37
Table 24	Package Thermal Coefficients.....	43



1. Introduction

The OCX256 is a differential crosspoint-switching device. The main functional block of the device is a Switch Matrix as shown in Figure 1. The Switch Matrix is a x - y structure supporting an input-to-output data flow. Figure 2 shows a conceptual view of the switch matrix with inputs connected to the horizontal trace and outputs to the vertical trace. The input and output ports connects to this horizontal-vertical trace pair through buffers. Signal path delays through the Switch Matrix are very well balanced, resulting in predictable and uniform pin-to-pin delays.

Note – For the purpose of clarity, the logic diagrams within this data sheet are conceptual representations only and do not show actual circuit implementation.

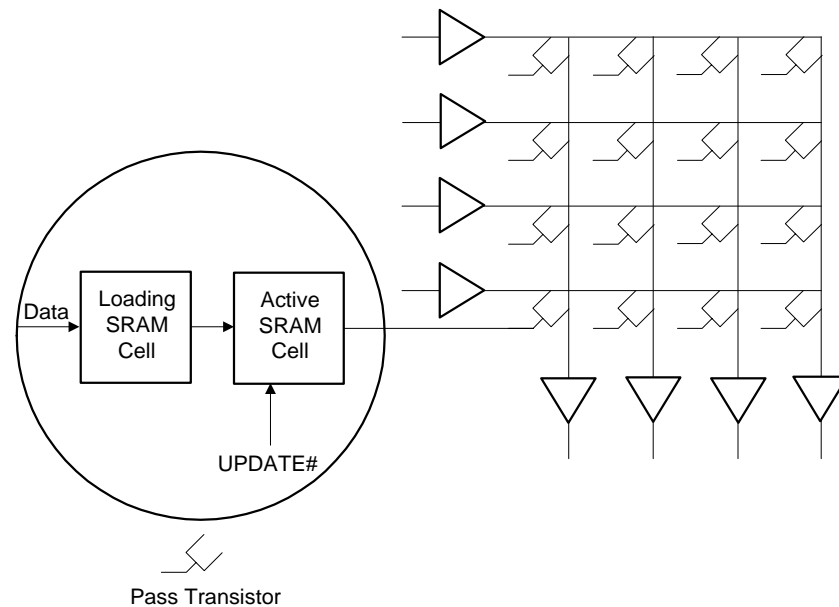

Figure 2 OCX256 Switch Matrix

The Active SRAM cells are responsible for establishing connections in the switch matrix by turning on a pass transistor, while the Loading SRAM cell can be used to store a second configuration that can be transferred to the Active SRAM cell at any time. The two SRAM cells are arranged so that a double buffered scheme can be employed. Through the use of an internal signal (generated automatically by a programming cycle) it is possible to store a second configuration map in the Loading SRAM while the Active SRAM maintains its present connection status. If the UPDATE# signal is asserted low, the contents of the Loading SRAM cell are transferred to the Active SRAM cell and the switch matrix connection is either made or broken.

The UPDATE# signal can be used to control when the switch matrix is reconfigured. For instance, as long as the UPDATE# signal is de-asserted (held high), the Loading SRAM cells for the entire switch matrix could be changed without affecting the current configuration of the switch. When the UPDATE# signal is asserted low, the entire switch matrix would be reconfigured simultaneously. If the UPDATE# signal is asserted continuously, all crosspoint programming commands (generated by RapidConfigure or JTAG programming cycles) will take effect immediately, since the Loading SRAM cell's contents will be transferred directly to the Active SRAM cell.



1.1 Input and Output Buffers

All of the input buffers are differential inputs with flow-through mode. The output buffers are programmable for either flow-through or registered mode. Figure 3 shows the basic block diagram of the input and output blocks with the sources for the output control signals (OE# and CLK). The control signals are explained in more details in the following sections.

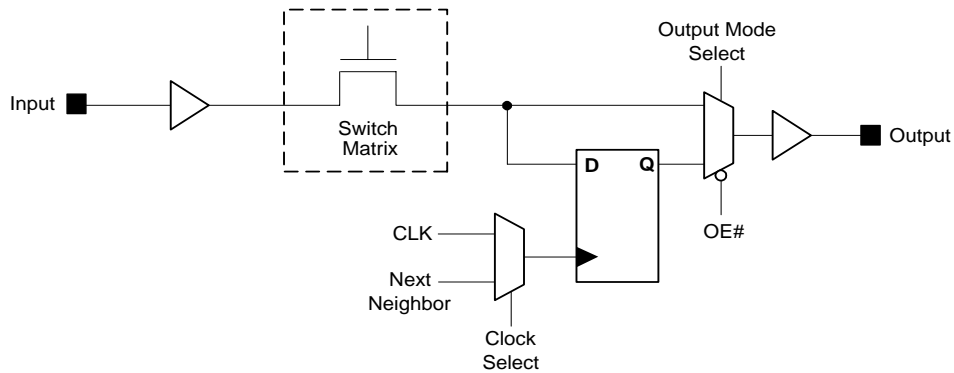

Figure 3 Input and Output Buffer Configuration

1.1.1 Input and Output Port Function Mode

The following legend describes the various modes of the Input and Output Ports and the specification used by the OCXPro™ Software.

Legend:

Ax—Switch Matrix Signal

Px—Port Signal

OE#—Output Enable (# means “Active Low”)

CLK—Clock

Table 1 Summary for Programmable I/O Attributes for OCX256

Symbol	I/O Port Function	Mnemonic
	Input – The external signal is buffered from the Input Port pin to the corresponding Switch Matrix line.	IN
	Output – The internal signal is buffered from the corresponding Switch Matrix line to the Output Port pin. In this mode an optional output enable (OE#) can be selected. The default state is logic high with enable set to ON.	OP
	Registered Output – The internal signal on the Switch Matrix line is registered by an edge-triggered register within the Output Port. A clock source is required in this mode. An output enable (OE#) is available but not required.	RO
	No Connect – In this mode, the output Port pin is isolated from the Switch Matrix.	NC



1.1.2 Broadcast Mode

The OCX256 has a special Broadcast Mode which connects any input to all outputs without performance degradation. The input is selected using RapidConfigure or JTAG and disconnects all other inputs. The Global Update pin (UPDATE#) must be held high during Broadcast Mode. Asserting the UPDATE# pin returns the array to the previous program condition.

1.2 Output Buffer Configuration

Every output port of the OCX256 can be configured as either a flow-through or registered output. In registered mode there are two clock sources that are available:

- Global Clock
- Next Neighbor

Additionally, there are output control signals.

1.2.1 Output Control Signals

Every output port of the OCX has a global Output Enable signal (OE#). All output buffers have output enables that have programmable polarity and are individually configurable.

Additionally each output can be permanently enabled (always ON) or disabled (always OFF) which is useful for applications which need to tri-state outputs (for example when using multiple chips in expansion mode) or for power saving in designs that do not need to use all the outputs available.

Two control bits are used to control the function of the output enable function as described in Table 5.

1.2.2 Neighboring Output Port as a Clock Source

A physically adjacent port can be used as a clock source for an output port configured in registered mode. These outputs are grouped in pairs such that the signal being switched through OUT0 can be used to clock the signal being switched through OUT1, and vice versa. Any single clock or data input signal can be used to clock any other input signal provided they are switched to an appropriate output pair (see Table 2). Figure 4 shows the implementation of next neighbor output port clocking in the OCX256 switch.

For example, IN_x is used for data input while IN_y is used for the corresponding clock. IN_x is connected to OUT0 via the crosspoint array while IN_y is connected to OUT1 via the crosspoint array. OUT0 is configured in registered output (RO) mode with OUT1 as its next neighbor clock selection. OUT1 will output the clock signal as well as clock the data in OUT0. Adjacent port selection is required for next neighbor clocking in the registered output mode.

This feature is useful in many applications where different types of data switching through the crosspoint array have various associated clocks. To match the delays in the data and corresponding clocks, it is common practice to pass the clocks through the switch along with the data.

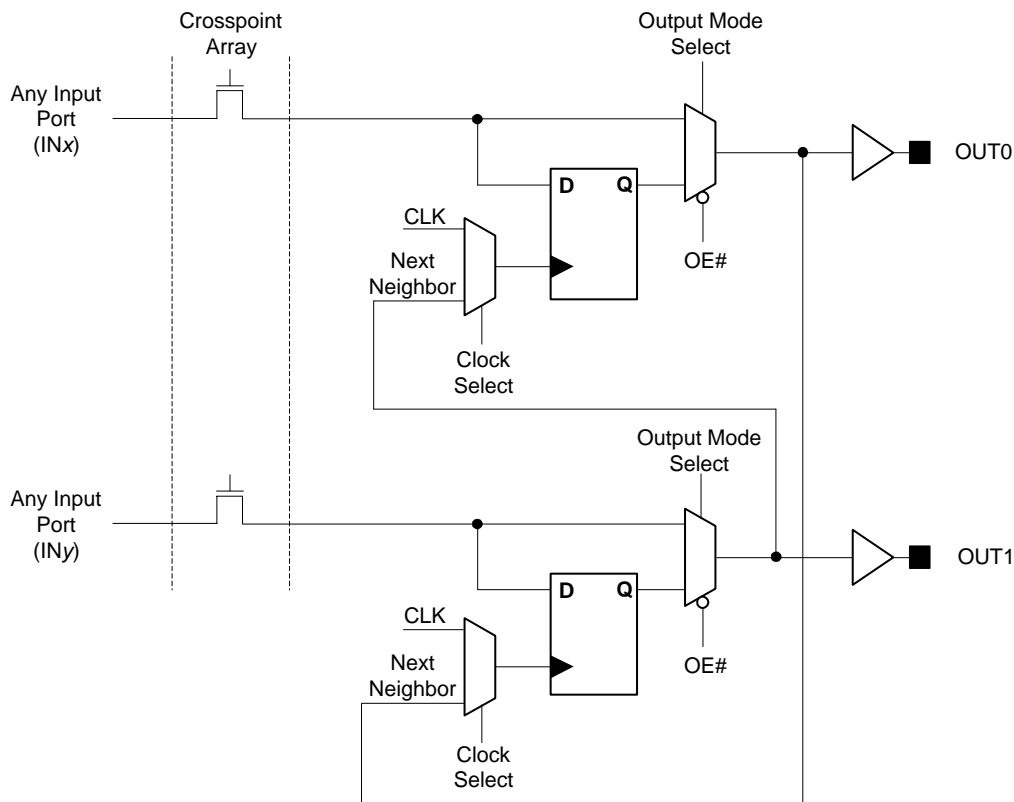

Figure 4 Next Neighbor Clock Block Diagram

The advantages of next neighbor clocking are:

1. Using next neighbor clocking in the registered output (RO) mode helps reduce the skew in outgoing data.
2. For a design with a large number of outputs switching simultaneously, next neighbor clocking mode is useful to stagger outputs for reduced board noise caused by simultaneous switching outputs.

Note – Selecting the next neighbor clock for both outputs at the same time is not recommended. Only one output in the pair at a time can be clocked by its next neighbor.

Table 2 Next Neighbor Outputs

Pairing Sequence for Neighboring Outputs								
Output Next Neighbor Pairs	0,1	2,3	4,5	6,7	8,9	▶▶▶▶	124,125	126,127

Only OUT1 can neighbor with OUT0, OUT3 with OUT2, etc. OUT2 cannot neighbor with OUT1, or OUT4 with OUT3, etc.



1.3 RapidConfigure Interface

RapidConfigure (RC) is a 25 signal parallel interface that is used to program the OCX256 device. The 25 pins are allocated as follows:

RCA[6:0] = RapidConfigure Address A. RCA are input pins.

RCB[6:0] = RapidConfigure Address B. RCB are input pins.

RCI[3:0] = RapidConfigure Instruction Bits

RCO[4:0] = RapidConfigure Readback. RCO are output pins.

RC_CLK# = RapidConfigure Clock (negative edge clock)

RC_EN# = RapidConfigure Cycle Enable (active low)

1.3.1 RapidConfigure Programming Instructions

The RC interface supports both write and read types of operations:

1. Write Operations (reset crosspoint and Input or Output Buffer (IOB), configure an Output Buffer, connect/disconnect crosspoint)
2. Read Operations (Output Buffer and crosspoint configuration read).

Table 3 RapidConfigure Programming Instructions

RCI[3:0]	RCA[6:0]	RCB[6:0]	RCO[4:0]	Instruction	Description
0000				Reserved	
0001				Reserved	
0010	X	X		Reset Crosspoint Array	Reset the entire crosspoint array to no connect. All Output Buffers remain unchanged by this operation.
0011	X	Input Port Address		Set Array to Broadcast mode	Connects the input selected by RCB[6:0] to all output ports and disconnects all other inputs. The Global Update (UPDATE#) pin must be held high during Broadcast mode. Activating the Global Update pin returns the array to the previous program condition.
0100	Output Port Address	Data		Configure an Output Buffer	Program an Output Buffer specified by RCA[6:0]. See Table 5 for RCB[6:0] bit assignment and buffer functionality.
0101				Readback Crosspoint, Output Buffer status	This is a two-cycle instruction.
<u>Cycle 1</u>	Output Port Address	Input Port Address	X		Specify the crosspoint connect status at input location specified by RCA[6:0] to the output location specified by RCB[6:0].



Table 3 RapidConfigure Programming Instructions (Continued)

RCI[3:0]	RCA[6:0]	RCB[6:0]	RCO[4:0]	Instruction	Description
<u>Cycle 2</u>	X	X	Output Data		Readback (using RCO[4:0]) the status of the input buffer specified in Cycle 1 by RCA[6:0], the output buffer specified in Cycle 1 by RCO[4:0] and the crosspoint connect status. See Table 4 for RCO[4:0] readback pin assignment.
0110	X	X		Update	Program the Global Update function without the use of the UPDATE# pin.
0111	X	Input Port Address		Disconnect Input	Disconnect the crosspoint cells of the input row location specified by RCA[6:0].
1000	Output Port Address	Input Port Address		Disconnect Input and Output	Disconnect the crosspoint cell at the input location specified by RCA[6:0] to the output location specified by RCB[6:0]. All other connections from the source input address or to the same output address remain the same as before.
1001	Output Port Address	Input Port Address		Connect, with ImpliedDisconnect	Connect the crosspoint cell at the input location specified by RCA[6:0] to the output location specified by RCB[6:0]. All other connections from the same input address or to the same output address are set to no connect (NC).
1010	Output Port Address	Input Port Address		Connect, without ImpliedDisconnect	Connect the crosspoint cell at the input location specified by RCA[6:0] to the output location specified by RCB[6:0]. All other connections from the same input address remain the same as before.
1011				Reserved	
1100				Reserved	
1101	X	X		Reset All	Reset the switch matrix to no connects (NC). Output Buffers default to flow-through mode (OP) with output enable set to always enabled (ON). Output Buffer defaults to select Global Clock (CLK) source even though mode is OP.
1110				Reserved	
1111				Reserved	

Note – X = Don't care.



Table 4 RCO[4:0] Readback Pin Assignment

RCO[4:0]	Readback Location	Signal/Function
O4	Crosspoint	Connection Status: 0 = No connection (NC) — (default state at reset) 1 = Connected
O3	Output Buffer	Clock Select: 0 = Global Clock — (default state at reset) 1 = Next Neighbor
O2	Output Buffer	Output Mode: 0 = Flow-through (OP) — (default state at reset) 1 = Registered (RO)
O1, O0 0,0 0,1 1,0 1,1	Output Buffer	Output Enable: Output enabled (ON) – this is the default state at reset Output disabled (OFF) Output controlled by OE (active high) Output controlled by OE# (active low)

Table 5 Programming an Output Buffer using RapidConfigure

RCB[6:0]	Signal/Function
B6, B5, B4	Don't care
B3	Clock Select: 0 = Global Clock 1 = Next Neighbor
B2	Output Mode: 0 = Flow-through (OP) 1 = Registered (RO)
B1, B0 0,0 0,1 1,0 1,1	Output Enable: Output enabled (ON) – this is the default state at reset Output disabled (OFF) Output controlled by OE (active high) Output controlled by OE# (active low)

1.3.2 ImpliedDisconnect

ImpliedDisconnect is a feature that provides the ability to make fast switch connection changes. When using the RC instruction “Connect, with ImpliedDisconnect” to establish a new connection, any existing connection to that output port is automatically broken. Thus, a connection change, i.e. breaking an existing connection and then making a new one, can be accomplished in one RapidConfigure cycle.



1.4 JTAG Configuration Controller

The Output port attributes and the Switch Matrix connections can be programmed using the JTAG serial bus. The RapidConfigure Interface can be enabled or disabled using the JTAG serial bus.

The JTAG-based serial mode is always available for configuration regardless of whether the RapidConfigure mode is enabled or disabled. However, proper care must be taken when switching between JTAG and RapidConfigure for configuring the devices. Before attempting to change Switch Matrix connections or output port configuration through JTAG, the user must first ensure that the RapidConfigure mode is disabled by using JTAG serial mode to set the RCE bit to zero in the Mode Control Register.

1.4.1 JTAG Interface

The dedicated JTAG TAP interface is designed in compliance with the IEEE-1149.1. The standard interface has five pins: Test Data Out (TDO), Test Mode Select (TMS), Test Data In (TDI), Test Reset (TRST#), and Test Clock (TCK), which allow Boundary Scan Testing as well as device configuration and verification. The I-Cube supplied software will automatically generate the necessary bitstream from a higher-level textual description of the required configuration. Data on the TDI and TMS pins are clocked into the device on the rising edge of the TCK signal, while the valid data appears on the TDO pin after the falling edge of TCK. For more detailed information on JTAG programming, refer to the *OCX256 Register Programming Manual*.

1.4.2 Output Port Configuration

Output port configuration is accomplished by loading the appropriate bitstream into the programming registers present at each Output port. The JTAG serial bus is used to load configuration data into the Output port programming registers, one Output port at a time.

1.4.3 Switch Matrix Configuration

The contents of the SRAM cells controlling Switch Matrix connection can be modified using the JTAG. This is accomplished by loading the configuration data, one word at a time, into the SRAM cells in the Switch Matrix.

1.4.4 Mode Control Register Configuration

The OCX256 contains a single bit Mode Control Register used to store user flags for RapidConfigure Enable (RCE). These are required for proper functioning of the device. The contents of this register can be changed using the JTAG interface and a special JTAG instruction.

Table 6 Mode Control Register

RCE	Mode
0	RapidConfigure interface disabled (OFF)
1	RapidConfigure interface enabled (ON)



1.4.5 JTAG Architecture and Shift Registers

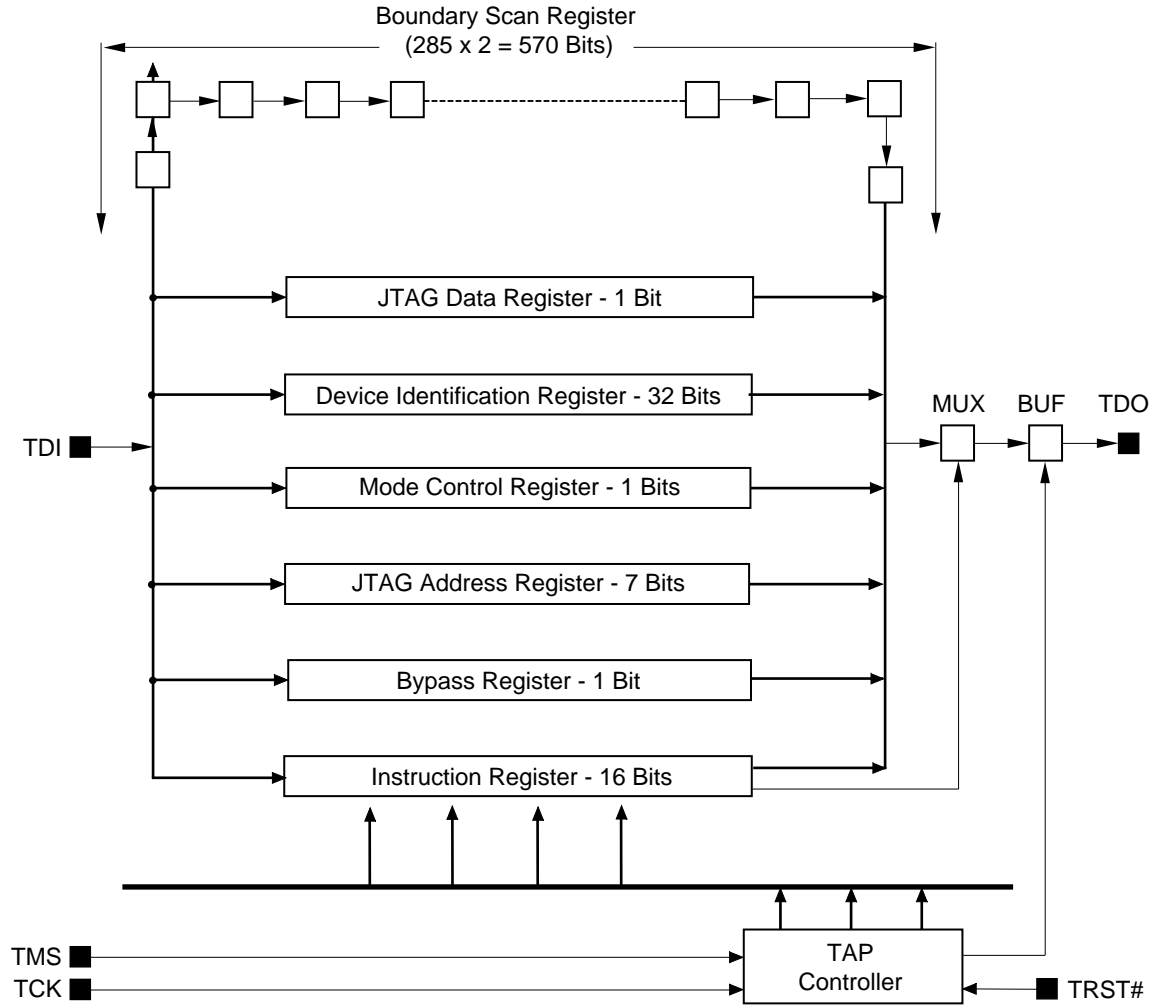

Figure 5 OCX256 JTAG Architecture



1.4.6 JTAG State Machine

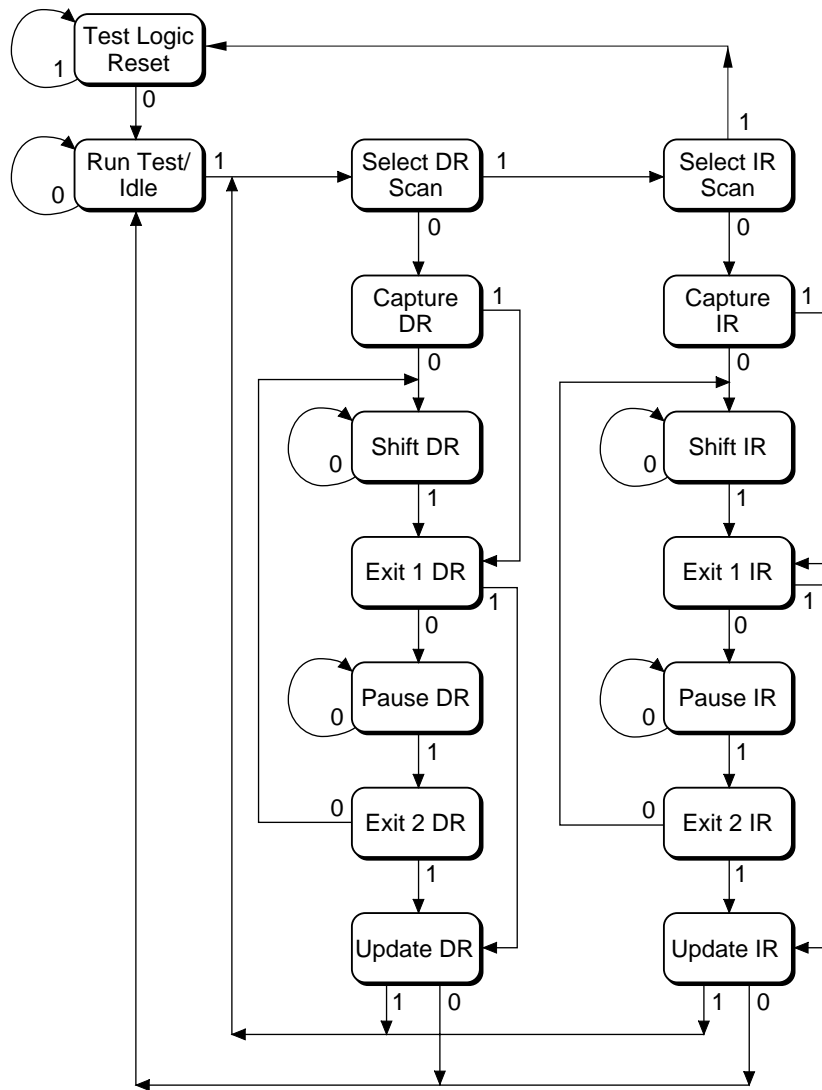

Figure 6 OCX256 JTAG State Machine

1.4.7 JTAG Input Format

Table 7 JTAG Input Format

	Instruction				Data					Address A						
Bit Number	15	14	13	12	11	10	9	8	7	6	5	4	3	2	1	0
Bit Name	I3	I2	I1	I0	BB	BA	B9	B8	B7	A6	A5	A4	A3	A2	A1	A0



1.4.8 JTAG Instructions

Table 8 JTAG Instructions

I [3:0]	BB	BA	B9	B8	B7	A6-A0	Instruction	Description
0 0 0 0	X	X	X	X	X	X	Sample/EXTEST	Places the device in scan mode.
0 0 0 1	X	X	X	X	X	X	Sample/EXTEST	Places the device in scan mode.
0 0 1 0	X	X	X	X	X	X	Reset the Crosspoint Array	Resets the entire Crosspoint Array to no-connect. All other Output Buffer configurations are unchanged by this operation.
0 0 1 1	X	X	X	X	X	X	Set Array for Broadcast mode	Use the JTAG Address Register as the Input address to be the broadcast input Connects the selected Input to all Output cells and disconnects all other Inputs. Activating the Global Update JTAG instruction returns the Crosspoint array from the Broadcast mode to the previous programed state.
0 1 0 0	X	Clock Select	Data Mode	OE	OE	Output Buffer Address	Program a Buffer	Programs the Output Buffer address specified in the JTAG instruction (A6-A0). The configuration data is also specified in the JTAG instruction bits BA-B7. See Table 9 for bit assignment of the Buffer functionality.
0 1 0 1	X	X	X	X	X	Output Address/ Buffer	Configuration readback	<p>Readback the connectivity of the Crosspoint cell with the Input location specified in the JTAG Address Register and the Output location specified JTAG instruction (A0-A6). It also returns the configuration of the Output Buffer addressed in the JTAG instruction (A0-A6).</p> <p>The readback data is shifted out of TDO in the following sequence:</p> <ol style="list-style-type: none"> 1. Crosspoint Connect (1=connected, 0=no connection) 2. Output Enable—B7 (see Table 9) 3. Output Enable—B8 (see Table 9) 4. Output Data Source—B9 (0=Flow-through, 1=registered) 5. Output Clock Select—BA (0=Global Clock, 1=Next Neighbor) 6. State of Broadcast bit 7. State of the RCE bit <p>NOTE: This instruction does not increment the JTAG Address Register. This instruction also requires two DR cycles</p>
0 1 1 0	X	X	X	X	X	X	Update the Crosspoint Array	Update the programmed connection from the Loading SRAM to the Active SRAM.
0 1 1 1	X	X	X	X	X	X	Disconnect Input cell	Disconnect the Crosspoint connections from the Input address specified in the JTAG Address Register.



Table 8 JTAG Instructions (Continued)

I [3:0]	BB	BA	B9	B8	B7	A6-A0	Instruction	Description
1 0 0 0	X	X	X	X	X	Output Address	Disconnect Input and Output	Disconnect the Crosspoint cell at the Input location specified at the JTAG Address Register and the Output location specified in the Disconnect JTAG instruction (A6-A0). All other connections from the same input address or to the same output address remain the same.
1 0 0 1	X	X	X	X	X	Output Address	Connect with ImpliedDisconnect	Connects the Crosspoint cell at the Input location specified on the JTAG Address Register and the output location specified in the Connect JTAG instruction (A6-A0). All other connections from the same Input address or the same Output address are set to no-connects. NOTE: This instruction increments the JTAG Address Register (Input address).
1 0 1 0	X	X	X	X	X	Output Address	Connect—no ImpliedDisconnect	Connects the Crosspoint cell at the Input address specified in the JTAG Address Register and the Output address specified in the Connect JTAG instruction (A6-A0). All other connections from the same input remain the same as before.
1 0 1 1	X	X	X	X	X	Input Address	Set the JTAG Address Register	Sets the 7-bit JTAG Address Register with the 7-bit address (A6-A0) of the JTAG Instruction Register. The 7-bit address of the JTAG Address Register becomes the Input port address for Crosspoint Access.
1 1 0 0	X	X	X	X	X	X	Device ID out	Serialize the device ID and revision history out to TDO. ID for the OCX256 is 0x0000C89F
1 1 0 1	X	X	X	X	X	X	Reset Output Buffer and Crosspoint Array	Resets the Crosspoint Array to no-connects. Sets the Output buffer to Flow-through mode with Output Enabled. The device ID is serialized to TDO.
1 1 1 0	X	X	X	X	X	X	Set RCE Bit	Sets the RCE bit of the Mode Control Register with the JTAG instruction bit A0. To turn ON the RCE bit, encode bit A0 to 1. To turn OFF the RCE bit, encode bit A0 to 0.
1 1 1 1	X	X	X	X	X	X	Bypass	Places device in a mode to pass TDI data to TDO with one clock delay. Used for programming and testing devices through serial connected JTAG controls.



Table 9 Programming an Output using JTAG

BA, B9, B8, B7	Signal/Function
BA	Clock Select: 0 = Global Clock 1 = Next Neighbor
B9	Output Mode: 0 = Flow-through (OP) 1 = Registered (RO)
B8, B7	Output Enable: 0,0 Output enabled (ON) – this is the default state at reset 0,1 Output disabled (OFF) 1,0 Output controlled by OE (active high) 1,1 Output controlled by OE# (active low)

Table 10 Number of JTAG Cycles and Configuration Time

Operation	OCX256
	JTAG Cycles
JTAG Reset Sequence (TMS = “11111”)	7
Enable or Disable RapidConfigure	28
Change attributes of ONE Output Port	28
Change attributes of ALL Output Ports	3,584
Reset JTAG Controller + Reset ALL Output Ports + Clear ALL SRAM cells	35
Connect or disconnect two Ports	56
Configure Entire Switch Matrix	462,336
Completely Configure the Device (All Output Ports and All Switch Matrix Connections)	456,920



1.5 Device Reset Options

The power-on reset, RapidConfigure reset, hardware reset, and JTAG reset functions will program the output buffers to flow-through mode (with Global Clock selected), and Output Enabled (ON). JTAG can be reset via the TRST# pin or by clocking five consecutive one to the TMS pin. The hardware reset pin can be done accomplished through the HW_RST# pin (active low). RC reset can be accomplished by applying the RC instruction 1101 to the RCI[3:0] pins.

Table 11 Device Reset Options

Programming Interface	Reset Method	Output Ports	Switch Matrix	RCE Mode Control	JTAG TAP
Hardware Reset	Power-on Reset	OP	NC	1 (RC Enabled)	TLR ¹
	HW_RST# (low pulse)	OP	NC	1 (RC Enabled)	TLR
JTAG Reset	1. Low Pulse on TRST#	Unchanged	Unchanged	Unchanged	TLR
	2. TMS high for 5 TCLK cycles	Unchanged	Unchanged	Unchanged	TLR
	3. Device Reset (instruction 1101)	OP	NC	1 (RC Enabled)	TLR
	4. Reset Crosspoint Array (instruction 0010)	Unchanged	NC	Unchanged	Unchanged
RapidConfigure Reset	1. Device reset (instruction 1101)	OP	NC	1 (RC Enabled)	Unchanged
	2. Reset Crosspoint Array (instruction 0010)	Unchanged	NC	Unchanged	Unchanged

1. TLR = Test Logic Reset state.



2. Pin Description

Table 12 OCX256 Pin Description

Pin Name	# of Pins	Type	Description
INPP[127:0]	128	Input	Non-inverting differential input signals
INN[127:0]	128	Input	Inverting differential input signals
OUTP[127:0]	128	Output	Non-inverting differential input signals
OUTN[127:0]	128	Output	Inverting differential input signals
CLKP	1	Input	Non-inverting differential Global Clock
CLKN	1	Input	Inverting differential Global Clock
OE#	1	Input	Global Output Enable
HW_RST#	1	Input	Hardware Reset
UPDATE#	1	Input	Global Update
RC Pins			
RCA[6:0]	7	Input	RapidConfigure Address A
RCB[6:0]	7	Input	RapidConfigure Address B
RCO[4:0]	5	Output	RapidConfigure Readback
RCI[3:0]	4	Input	RapidConfigure Instruction Bits
RC_CLK#	1	Input	RapidConfigure Clock
RC_EN#	1	Input	RapidConfigure Cycle Enable
JTAG Pins			
TCK	1	Input	JTAG Test Clock
TMS	1	Input	JTAG Test Mode Select
TDI	1	Input	JTAG Test Data In
TRST#	1	Input	JTAG Test Reset
TDO	1	Output	JTAG Test Data Out
Power and Ground Pins			
V _{DD} -CORE	12	2.5V Power	Core Voltage
V _{DD} -PAD ^(2, 3)	16	2.5V or 3.3V Power	Differential Output Buffer Voltage
V _{DD} -IN ^(1, 4)	14	3.3V Power	LVTTL Control pins Voltage and Differential Input Buffer Voltage
V _{SS}	36	Ground	Ground

NOTES:

1. Dedicated differential input buffers can receive both LVDS and LVPECL voltage levels using 3.3V supply.
2. V_{DD}-PAD is 2.5V for LVDS outputs or 3.3V for LVPECL outputs.
3. Dedicated differential output buffers can be biased using different supplies for V_{DD}-PAD and external resistors to support both LVDS and LVPECL output voltage levels.
4. The LVTTL control, JTAG pins, and differential input ports are 3.3V—they are not 5V tolerant.
5. The differential output pins powered from 2.5V are 3.3V tolerant.



3. Differential I/O Standards

The OCX256 supports the two most popular differential signaling standards: Low Voltage Differential Signaling (LVDS) and Low Voltage Positive Emitter Coupled Logic (LVPECL).

LVDS is typically used in communication systems as high speed, low noise point-to-point links. The OCX256 conforms to the ANSI/TIA/EIA-644 standard covering electrical specifications for output drivers and receiver inputs.

LVPECL is commonly used in video switching applications or those designs requiring transmission of high-speed clock signals.

3.1 LVDS

LVDS is a differential signaling standard. It requires that one data bit is carried through two signal lines. As with all differential signaling standards, LVDS has an inherent noise immunity over single-ended standards. The voltage swing between two signal lines is approximately 350mV. The use of a reference voltage or a board termination voltage is not required. LVDS requires the use of two pins per input or output. LVDS requires external resistor termination.

Transmitting and receiving circuits for LVDS are shown in Figures 7 and 8.

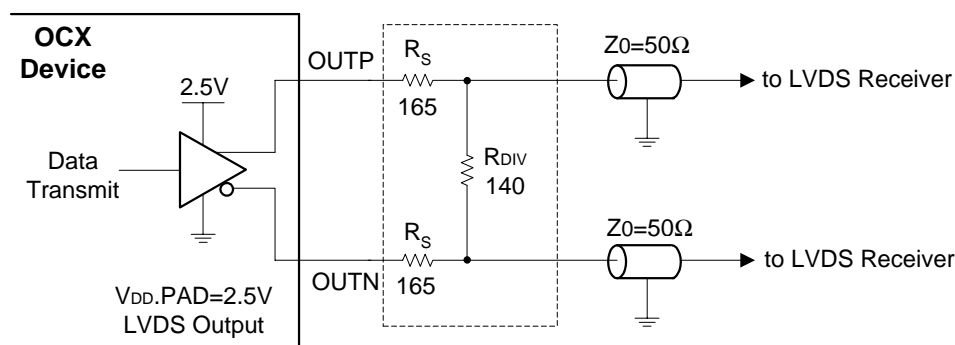

Figure 7 Transmitting LVDS Signal Circuit

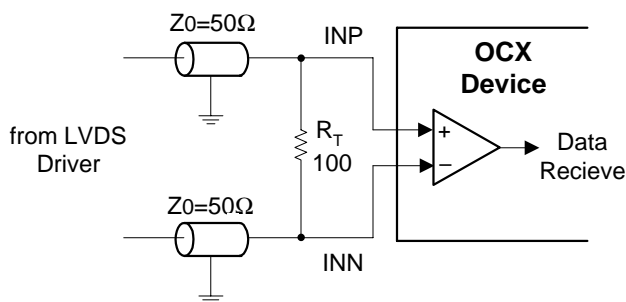

Figure 8 Receiving LVDS Signal Circuit



3.2 LVPECL

LVPECL is another differential signaling standard that specifies two pins per input or output. The voltage swing between these two signal lines is approximately 850 mV. The use of a reference voltage or a board termination voltage is not required. The LVPECL standard requires external resistor termination.

Transmitting and receiving circuits for LVPECL are shown in Figures 9 and 10.

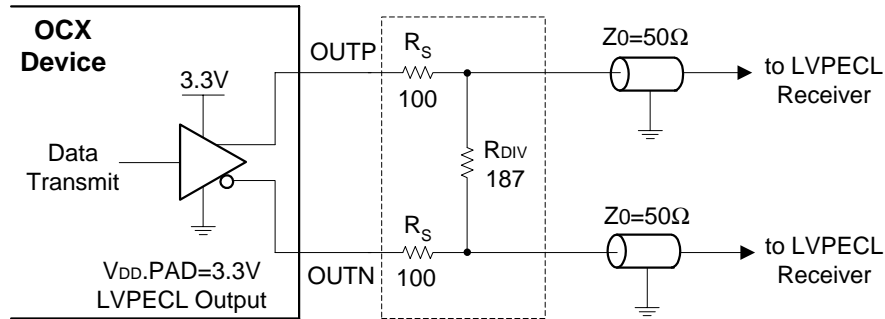

Figure 9 Transmitting LVPECL Signal Circuit

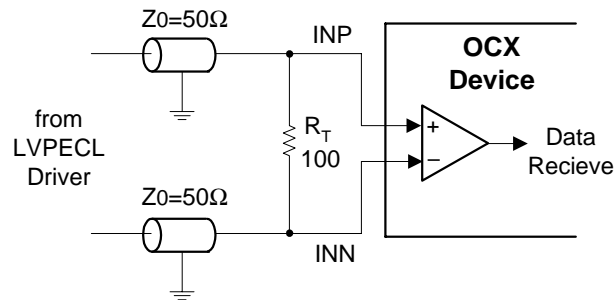

Figure 10 Receiving LVPECL Signal Circuit



3.3 Termination Resistor Packs

Resistor packs are available with the values and the configuration required for LVDS and LVPECL termination from Bourns, Inc. The part numbers are listed in Table 13. For pricing and availability questions, please contact them directly at www.bourns.com.

Table 13 Termination Resistor Packs

Bourns Part Number	Differential I/O Standard	Termination for:	Pairs per Pack	No. of Pins
CAT16-LV2F6	LVDS	Driver	2	8
CAT16-LV4F12	LVDS	Driver	4	16
CAT16-PC2F6	LVPECL	Driver	2	8
CAT16-PC4F12	LVPECL	Driver	4	16
CAT16-PT2F2	LVDS/LVPECL	Receiver	2	8
CAT16-PT4F4	LVDS/LVPECL	Receiver	4	16

3.4 Mixed I/O Systems

The use of different supply voltages and terminating resistors allows the OCX256 to support LVDS / LVPECL translation as well as switching as outlined in Table 14.

Table 14 Supply Voltages and Terminating Resistors

Input	Output	V _{DD,PAD}	R _T	R _S	R _{DIV}
LVDS	LVDS	2.5V	100Ω	165Ω	140Ω
LVPECL	LVDS	2.5V	100Ω	165Ω	140Ω
LVDS	LVPECL	3.3V	100Ω	100Ω	187Ω
LVPECL	LVPECL	3.3V	100Ω	100Ω	187Ω

NOTES:

1. V_{DD,IN} = 3.3V ±10%, V_{DD,CORE} = 2.5V ±5%
2. It is not possible to mix LVDS and LVPECL outputs on a device



4. Electrical Specifications

4.1 Absolute Maximum Ratings

Table 15 Absolute Maximum Ratings¹

Symbol	Parameter	Limits	Units
V _{DD} .CORE	Supply Voltage (core)	-0.3 to +3.0	V
V _{DD} .IN	Supply Voltage (inputs)	-0.3 to +3.6	V
V _{DD} .PAD	Supply Voltage (differential outputs)	-0.3 to +3.6	V
V _{IN} ⁽²⁾	Input Voltage	-0.3 to +3.6 ⁽³⁾	V
T _J	Junction Temperature	+150	°C
T _{STG}	Storage Temperature	-65 to +150	°C
P _{MAX}	Maximum Power Dissipation	7	W
ESD ⁽⁶⁾	Electrostatic Discharge	2000	V

4.2 Recommended Operating Conditions

Table 16 Recommended Operating Conditions

Symbol	Parameter	Limits	Units
V _{DD} .CORE	Supply Voltage (core)	+2.375 to +2.625	V
V _{DD} .PAD ⁽⁴⁾	Supply Voltage (differential output buffers)	3.3V ±10% to 2.5V ±5%	V
V _{DD} .IN	Supply Voltage (inputs)	+3.0 to +3.6	V
T _A	Operating Temperature: Commercial Operating Temperature: Industrial	0 to +70 -40 to +85	°C

4.3 Pin Capacitance

Table 17 Pin Capacitance⁵

Symbol	Parameter	Max	Units
C _{PIN}	Signal Pin Capacitance	10	pF

1. Exposure to absolute maximum rated conditions for extended periods may affect device reliability.
2. A maximum undershoot of 2V for a maximum duration of 20 ns is acceptable. Overshoot to 3.6V is acceptable.
3. All inputs are 3.3V tolerant with the V_{DD} pin at 2.5V or 3.3V.
4. Note that min and max values for V_{DD} for differential outputs are I/O Standard dependent.
5. Capacitance measured at 25°C. Sample tested only.
6. Measured using Human Body Model.



4.4 DC Electrical Specifications

($T_A = -40^{\circ}\text{C}$ to 85°C , $V_{DD.IN} = 3.3\text{V} \pm 10\%$, $V_{DD.CORE} = 2.5\text{V} \pm 5\%$)

Table 18 LVTTTL DC Electrical Specifications

Symbol	Parameter	Conditions	Min	Max	Units
V_{IH}	High-level Input	Ports are 3.3V tolerant	2.0	3.6	V
V_{IL}	Low-level Input	Ports are 3.3V tolerant	-0.3	0.8	V
V_{OH}	High-level Output	$V_{DD.PAD} = \text{Min}$ $I_{OH} = -4\text{mA}$	2.4	$V_{DD.PAD} + 0.3$	V
V_{OL}	Low-level Output	$V_{DD.PAD} = \text{Min}$ $I_{OL} = 8\text{mA}$		0.4	V
$IL_{IH}, IL_{IL}^{(1)}$	Input Pin Leakage Current	$V_{DD.IN} = \text{Max}$ $0.0 < I_n < V_{DD.PAD}$		+5 -50	μA
IL_{OZ}	Tristate Leakage Output OFF State	$V_{DD.PAD} = \text{Max}$ $0.0 < I_n < V_{DD.PAD}$		+5 -5	μA
Power					
$P_{DDQ}^{(2)}$	Quiescent Power	All $V_{DD} = \text{Max}$		0.7	W

Table 19 LVDS DC Electrical Specifications

DC Parameter	Min	Typ	Max	Units
Output High Voltage for OUTP and OUTN ⁽³⁾			1.6	V
Output Low Voltage for OUTP and OUTN	0.90			V
Differential Output Voltage ⁽⁵⁾	250	350	450	mV
Output Common-Mode Voltage	1.125	1.25	1.375	V
Differential Input Voltage	100	350		mV
Input Common-Mode Voltage	0.25	1.25	2.25	V

1. All LVTTTL input pins have pull-up resistors.
2. See section 6 for dynamic power consumption calculation.
3. Refer to Figures 7 and 8 for termination resistor.
4. Refer to Figures 9 and 10 for termination resistor.
5. Maximum capacitive load is 12 pF.

Table 20 LVPECL DC Electrical Specifications

DC Parameters	Min	Max
$V_{IH}^{(4)}$	1.49	2.72
V_{IL}	0.86	2.125
V_{OH}	1.975	2.720
V_{OL}	1.190	1.980



4.5 AC Electrical Specifications

($V_{DD-IN} = 3.3V \pm 10\%$, $V_{DD-CORE} = 2.5V \pm 5\%$)

Table 21 AC Electrical Specifications

Symbol	Parameter	0°C to 70°C		-40°C to +85°C		Units
		Min	Max	Min	Max	
R _{DATA}	NRZ Data Rate ⁽¹⁾		667		667	Mb/s
F _{RO}	Registered Output Clock Frequency ⁽¹⁾		333		333	MHz
t _{W_RO}	Registered Clock Pulse Width, High or Low ⁽¹⁾	2		2		ns
t _{S_RO}	Registered Output Setup Time to Clock	4		4		ns
t _{H_RO}	Registered Output Clock to Hold Data	0		0		ns
t _{CO_RO}	Registered Output Clock to Data Out Valid		2.5		2.5	ns
t _{PHL} , t _{PLH}	One Way Signal Propagation Delay, Fanout = 1		5.5		6.5	ns
t _{W+}	Input Flow-through Positive Pulse Width	1.5		1.5		ns
t _{W-}	Input Flow-through Negative Pulse Width	1.5		1.5		ns
t _{DCD+} , t _{DCD-}	Duty Cycle Distortion		0.5		0.6	ns
t _{JITTER}	Output Jitter	TBD	TBD	TBD	TBD	ps
t _{SK}	Skew between Output Ports ⁽¹⁾		0.5		0.6	ns
t _{PHZ_OT} , t _{PLZ_OT}	Output Enable to Valid Data		3		3	ns
t _{PZH_OT} , t _{PZL_OT}	Output Enable to High Z State		3		3	ns
t _{RC}	RapidConfigure Clock Period	12		12		ns
t _{W+_RC} , t _{W-_RC}	RapidConfigure Clock Pulse Width	5		5		ns
t _{S_RC}	RapidConfigure Address Setup to RC_CLK#	3		4		ns
t _{H_RC}	RapidConfigure Address and Enable Hold Time to RC_CLK#	3		4		ns
t _{P_UD}	Update of Crosspoint to Data Out		10		10	ns
f _{JTAG}	JTAG Clock Frequency (TCK)		20		20	MHz
t _{W_JTAG}	JTAG Clock Pulse Width (TCK) @ 20MHz cycle	20	30	20	30	ns
t _{S_JTAG}	JTAG Setup Time	4		4		ns
t _{H_JTAG}	JTAG Hold Time	0		0		ns
t _{P_JTAG}	JTAG Clock to Output Data Valid (TDO)		20		20	ns

NOTES:

1. These parameters are guaranteed but not tested in production.



4.6 Timing Diagrams

Note – For the purpose of clarity, the timing diagrams within this data sheet are conceptual representations only and do not show actual circuit implementation.

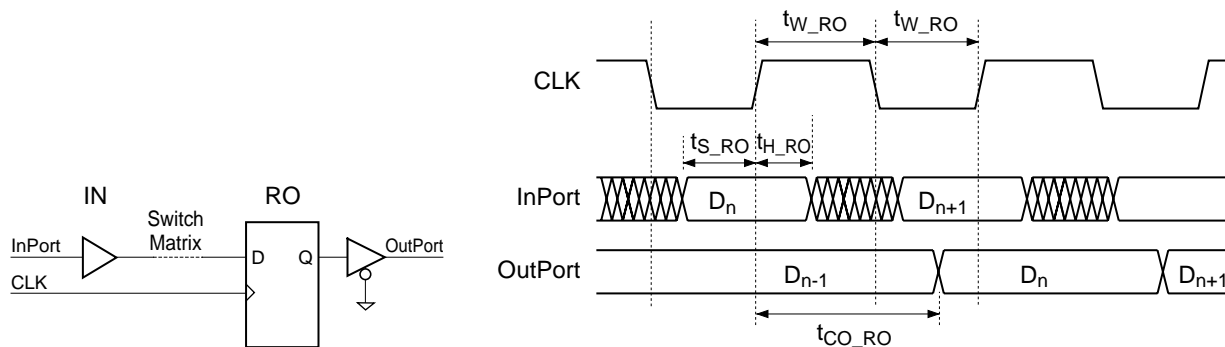

Figure 11 Registered Output Mode Timing

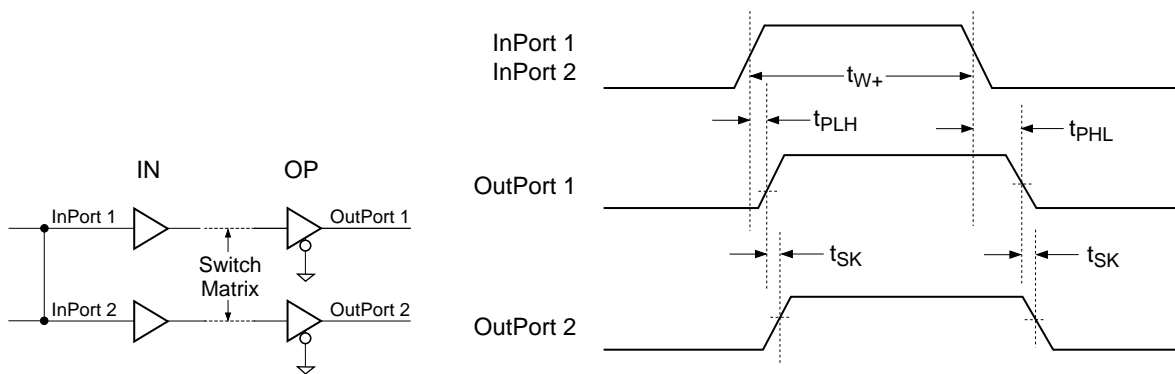

Figure 12 Flow-Through Mode Timing

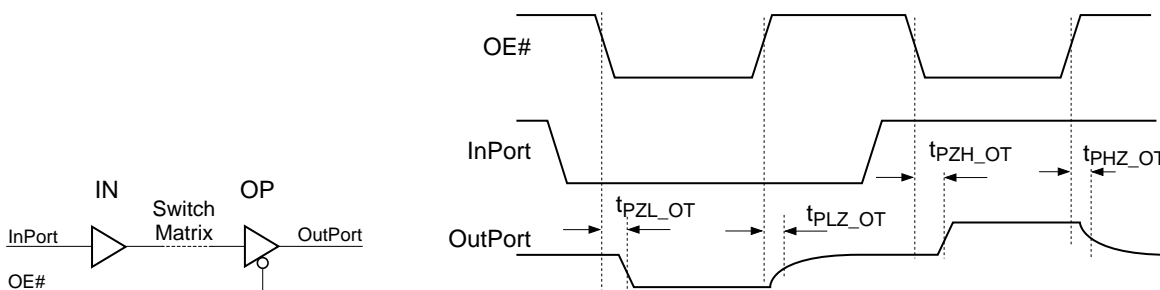

Figure 13 Output Enable Timing

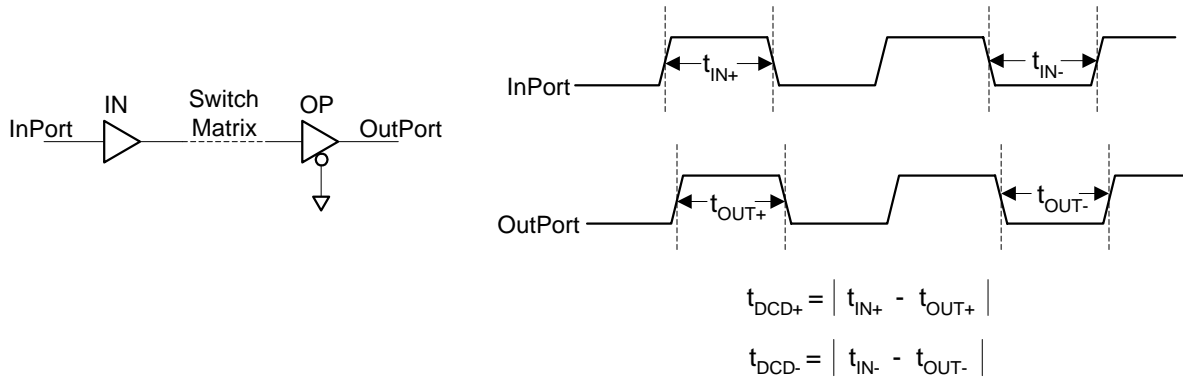

Figure 14 Duty Cycle Distortion

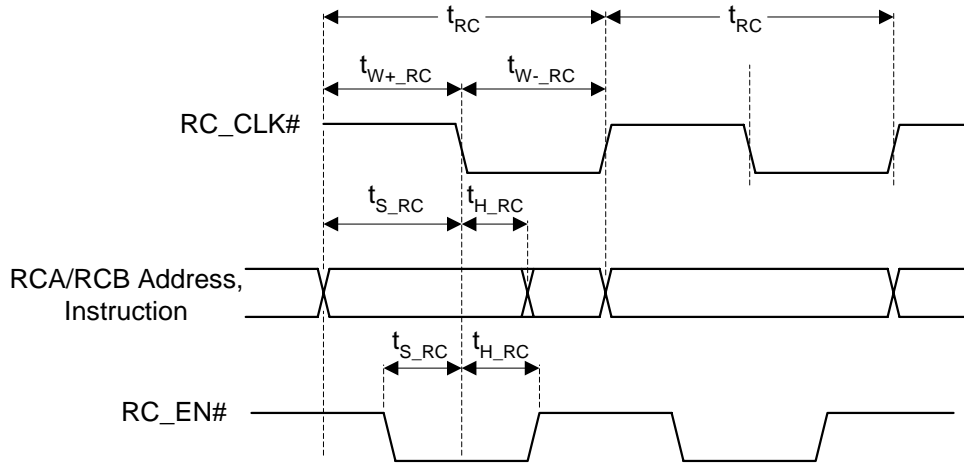

Figure 15 RapidConfigure Write Cycle

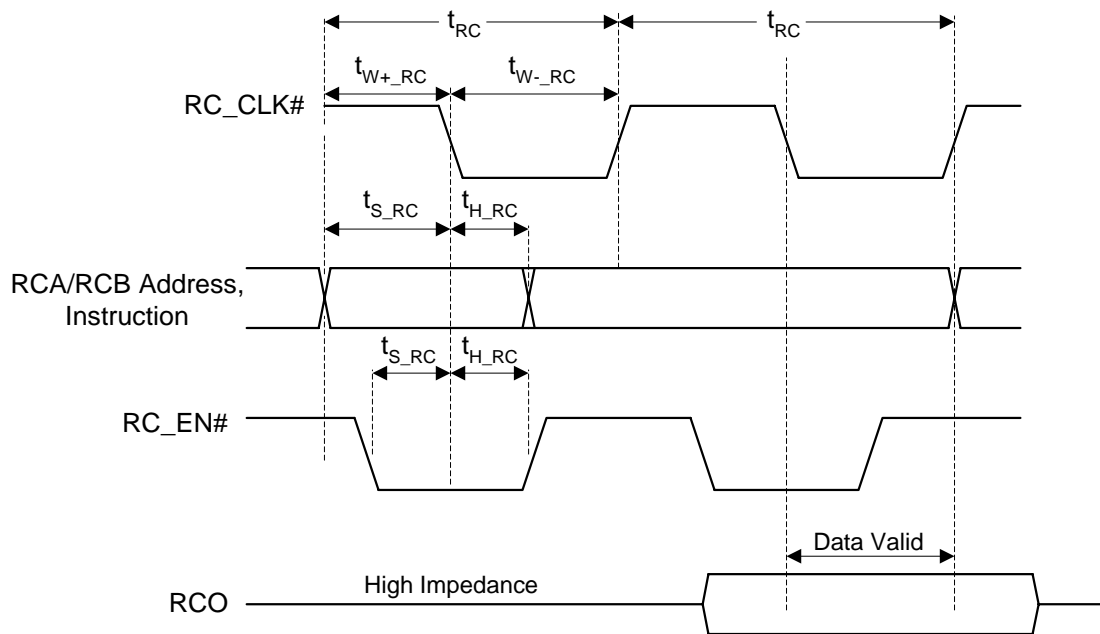

Figure 16 RapidConfigure Read Cycle

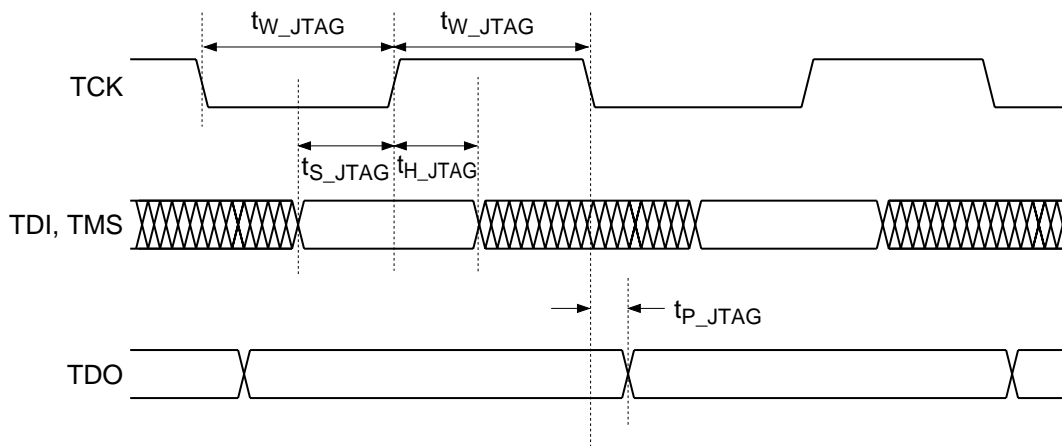

Figure 17 JTAG Timing

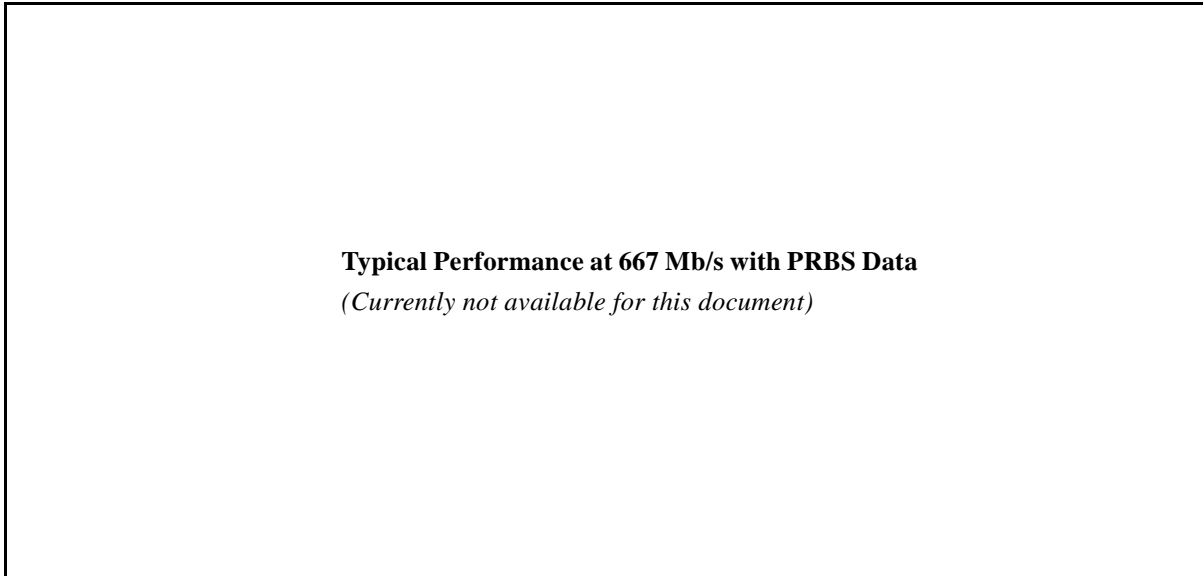

Figure 18 Typical Performance LVDS mode

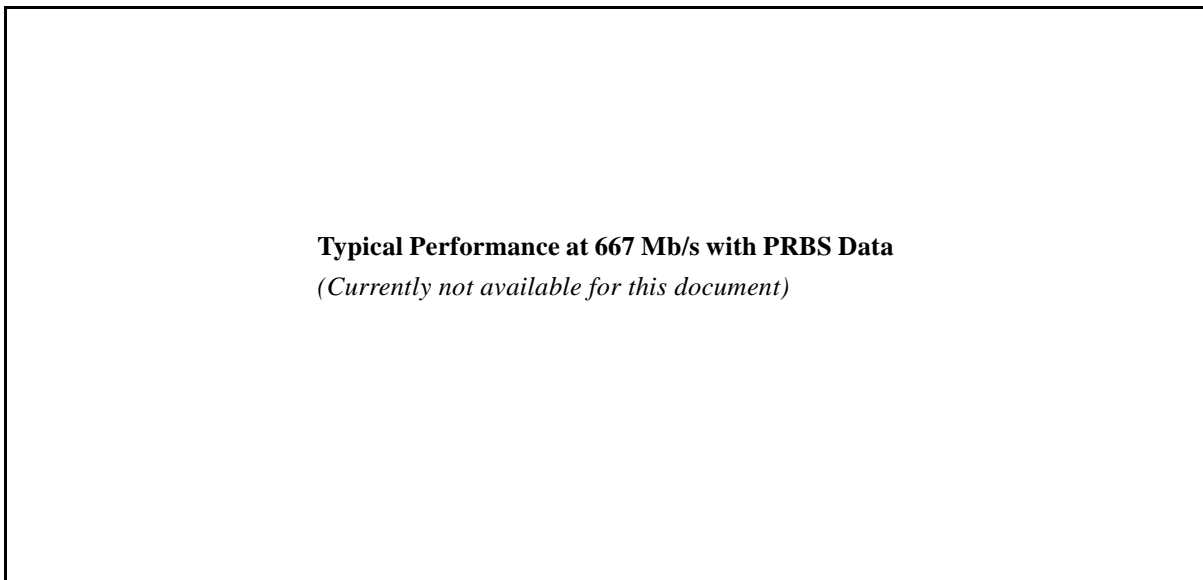

Figure 19 Typical Performance LVPECL mode



5. Package and Pinout

5.1 Package Pinout

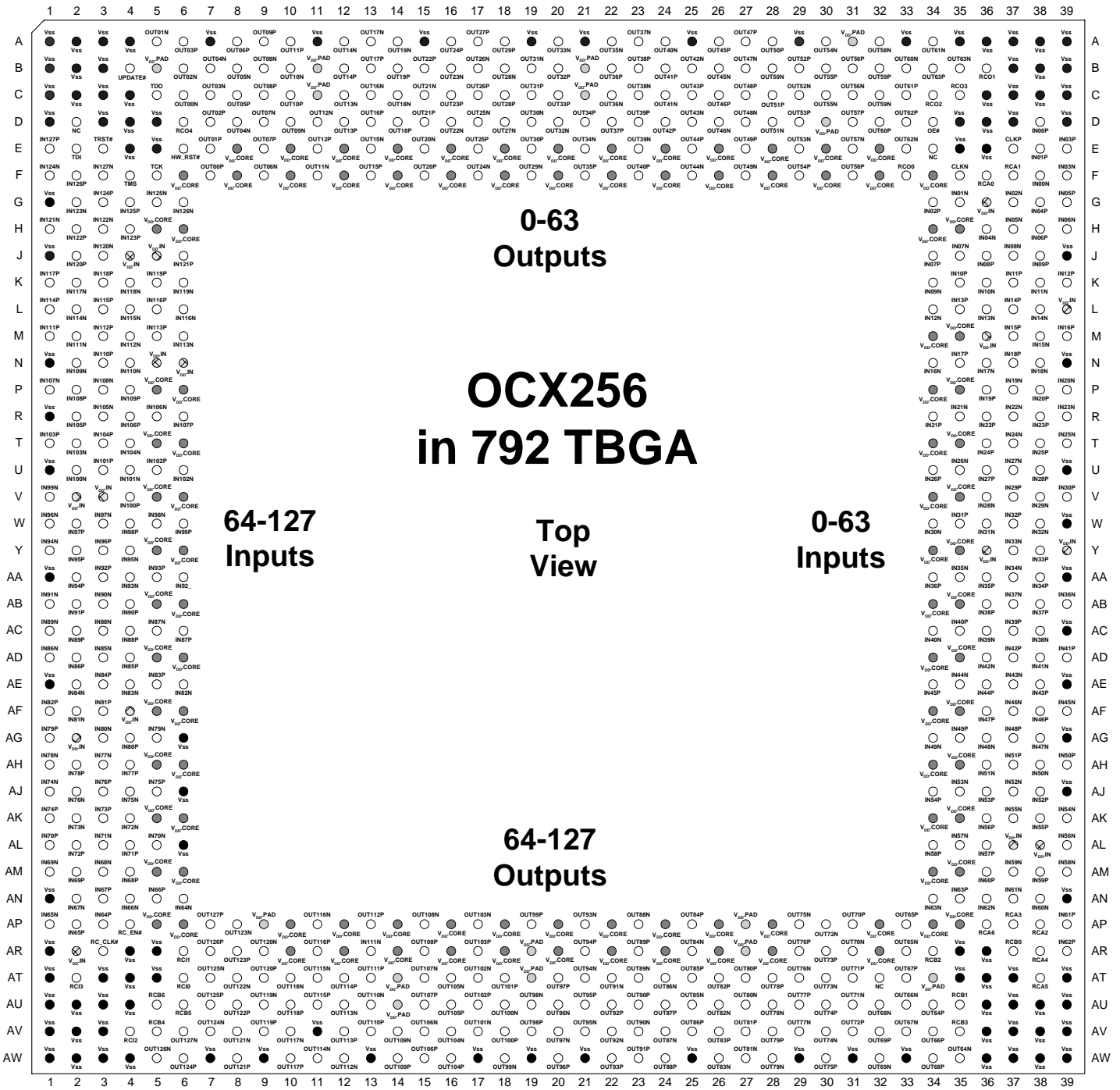

Figure 20 OCX256 Package Pinout



5.2 Pinout by Ball Sequence

Table 22 OCX256 Pinout By Ball Sequence

Ball #	Ball Name	Ball #	Ball Name	Ball #	Ball Name	Ball #	Ball Name	Ball #	Ball Name	Ball #	Ball Name
A1	V _{SS}	B1	V _{SS}	C1	V _{SS}	D1	V _{SS}	E1	IN127P	F1	IN124N
A2	V _{SS}	B2	V _{SS}	C2	V _{SS}	D2	NC	E2	TDI	F2	IN126P
A3	V _{SS}	B3	V _{SS}	C3	V _{SS}	D3	V _{SS}	E3	TRST#	F3	IN127N
A4	V _{SS}	B4	UPDATE#	C4	V _{SS}	D4	V _{SS}	E4	V _{SS}	F4	TMS
A5	OUT01N	B5	V _{DD} .PAD	C5	TDO	D5	V _{SS}	E5	V _{SS}	F5	TCK
A6	OUT03P	B6	OUT02N	C6	OUT00N	D6	RCO4	E6	HW_RST#	F6	V _{DD} .CORE
A7	V _{SS}	B7	OUT04P	C7	OUT03N	D7	OUT02P	E7	OUT01P	F7	OUT00P
A8	OUT06P	B8	OUT05N	C8	OUT05P	D8	OUT04N	E8	V _{DD} .CORE	F8	V _{DD} .CORE
A9	OUT09P	B9	OUT08N	C9	OUT08P	D9	OUT07N	E9	OUT07P	F9	OUT06N
A10	OUT11P	B10	OUT10N	C10	OUT10P	D10	OUT09N	E10	V _{DD} .CORE	F10	V _{DD} .CORE
A11	V _{SS}	B11	V _{DD} .PAD	C11	V _{DD} .PAD	D11	OUT12N	E11	OUT12P	F11	OUT11N
A12	OUT14N	B12	OUT14P	C12	OUT13N	D12	OUT13P	E12	V _{DD} .CORE	F12	V _{DD} .CORE
A13	OUT17N	B13	OUT17P	C13	OUT16N	D13	OUT16P	E13	OUT15N	F13	OUT15P
A14	OUT19N	B14	OUT19P	C14	OUT18N	D14	OUT18P	E14	V _{DD} .CORE	F14	V _{DD} .CORE
A15	V _{SS}	B15	OUT22P	C15	OUT21N	D15	OUT21P	E15	OUT20N	F15	OUT20P
A16	OUT24P	B16	OUT23N	C16	OUT23P	D16	OUT22N	E16	V _{DD} .CORE	F16	V _{DD} .CORE
A17	OUT27P	B17	OUT26N	C17	OUT26P	D17	OUT25N	E17	OUT25P	F17	OUT24N
A18	OUT29P	B18	OUT28N	C18	OUT28P	D18	OUT27N	E18	V _{DD} .CORE	F18	V _{DD} .CORE
A19	V _{SS}	B19	OUT31N	C19	OUT31P	D19	OUT30N	E19	OUT30P	F19	OUT29N
A20	OUT33N	B20	OUT32P	C20	OUT33P	D20	OUT32N	E20	V _{DD} .CORE	F20	V _{DD} .CORE
A21	V _{SS}	B21	V _{DD} .PAD	C21	V _{DD} .PAD	D21	OUT34P	E21	OUT34N	F21	OUT35P
A22	OUT35N	B22	OUT36P	C22	OUT36N	D22	OUT37P	E22	V _{DD} .CORE	F22	V _{DD} .CORE
A23	OUT37N	B23	OUT38P	C23	OUT38N	D23	OUT39P	E23	OUT39N	F23	OUT40P
A24	OUT40N	B24	OUT41P	C24	OUT41N	D24	OUT42P	E24	V _{DD} .CORE	F24	V _{DD} .CORE
A25	V _{SS}	B25	OUT42N	C25	OUT43P	D25	OUT43N	E25	OUT44P	F25	OUT44N
A26	OUT45P	B26	OUT45N	C26	OUT46P	D26	OUT46N	E26	V _{DD} .CORE	F26	V _{DD} .CORE
A27	OUT47P	B27	OUT47N	C27	OUT48P	D27	OUT48N	E27	OUT49P	F27	OUT49N
A28	OUT50P	B28	OUT50N	C28	OUT51P	D28	OUT51N	E28	V _{DD} .CORE	F28	V _{DD} .CORE
A29	V _{SS}	B29	OUT52P	C29	OUT52N	D29	OUT53P	E29	OUT53N	F29	OUT54P
A30	OUT54N	B30	OUT55P	C30	OUT55N	D30	V _{DD} .PAD	E30	V _{DD} .CORE	F30	V _{DD} .CORE
A31	V _{DD} .PAD	B31	OUT56P	C31	OUT56N	D31	OUT57P	E31	OUT57N	F31	OUT58P
A32	OUT58N	B32	OUT59P	C32	OUT59N	D32	OUT60P	E32	V _{DD} .CORE	F32	V _{DD} .CORE
A33	V _{SS}	B33	OUT60N	C33	OUT61P	D33	OUT62P	E33	OUT62N	F33	RCO0
A34	OUT61N	B34	OUT63P	C34	RCO2	D34	OE#	E34	NC	F34	V _{DD} .CORE
A35	V _{SS}	B35	OUT63N	C35	RCO3	D35	V _{SS}	E35	V _{SS}	F35	CLKN
A36	V _{SS}	B36	RCO1	C36	V _{SS}	D36	V _{SS}	E36	V _{SS}	F36	RCA0
A37	V _{SS}	B37	V _{SS}	C37	V _{SS}	D37	V _{SS}	E37	CLKP	F37	RCA1
A38	V _{SS}	B38	V _{SS}	C38	V _{SS}	D38	IN00P	E38	IN01P	F38	IN00N
A39	V _{SS}	B39	V _{SS}	C39	V _{SS}	D39	V _{SS}	E39	IN03P	F39	IN03N



Table 22 OCX256 Pinout By Ball Sequence (Continued)

Ball #	Ball Name	Ball #	Ball Name	Ball #	Ball Name	Ball #	Ball Name	Ball #	Ball Name	Ball #	Ball Name
G1	V _{SS}	H1	IN121N	J1	V _{SS}	K1	IN117P	L1	IN114P	M1	IN111P
G2	IN123N	H2	IN122P	J2	IN120P	K2	IN117N	L2	IN114N	M2	IN111N
G3	IN124P	H3	IN122N	J3	IN120N	K3	IN118P	L3	IN115P	M3	IN112P
G4	IN125P	H4	IN123P	J4	V _{DD} -IN	K4	IN118N	L4	IN115N	M4	IN112N
G5	IN125N	H5	V _{DD} -CORE	J5	V _{DD} -IN	K5	IN119N	L5	IN116P	M5	IN113P
G6	IN126N	H6	V _{DD} -CORE	J6	IN121P	K6	IN119P	L6	IN116N	M6	IN113N
G34	IN02P	H34	V _{DD} -CORE	J34	IN07P	K34	IN09N	L34	IN12N	M34	V _{DD} -CORE
G35	IN01N	H35	V _{DD} -CORE	J35	IN07N	K35	IN10P	L35	IN13P	M35	V _{DD} -CORE
G36	V _{DD} -IN	H36	IN04N	J36	IN08P	K36	IN10N	L36	IN13N	M36	V _{DD} -IN
G37	IN02N	H37	IN05N	J37	IN08N	K37	IN11P	L37	IN14P	M37	IN15P
G38	IN04P	H38	IN06P	J38	IN09P	K38	IN11N	L38	IN14N	M38	IN15N
G39	IN05P	H39	IN06N	J39	V _{SS}	K39	IN12P	L39	V _{DD} -IN	M39	IN16P

N1	V _{SS}	P1	IN107N	R1	V _{SS}	T1	IN103P	U1	V _{SS}	V1	IN99N
N2	IN109N	P2	IN108P	R2	IN105P	T2	IN103N	U2	IN100N	V2	V _{DD} -IN
N3	IN110P	P3	IN108N	R3	IN105N	T3	IN104P	U3	IN101P	V3	V _{DD} -IN
N4	IN110N	P4	IN109P	R4	IN106P	T4	IN104N	U4	IN101N	V4	IN100P
N5	V _{DD} -IN	P5	V _{DD} -CORE	R5	IN106N	T5	V _{DD} -CORE	U5	IN102P	V5	V _{DD} -CORE
N6	V _{DD} -IN	P6	V _{DD} -CORE	R6	IN107P	T6	V _{DD} -CORE	U6	IN102N	V6	V _{DD} -CORE
N34	IN16N	P34	V _{DD} -CORE	R34	IN21P	T34	V _{DD} -CORE	U34	IN26P	V34	V _{DD} -CORE
N35	IN17P	P35	V _{DD} -CORE	R35	IN21N	T35	V _{DD} -CORE	U35	IN26N	V35	V _{DD} -CORE
N36	IN17N	P36	IN19P	R36	IN22P	T36	IN24P	U36	IN27P	V36	IN28N
N37	IN18P	P37	IN19N	R37	IN22N	T37	IN24N	U37	IN27N	V37	IN29P
N38	IN18N	P38	IN20P	R38	IN23P	T38	IN25P	U38	IN28P	V38	IN29N
N39	V _{SS}	P39	IN20N	R39	IN23N	T39	IN25N	U39	V _{SS}	V39	IN30P

W1	IN96N	Y1	IN94N	AA1	V _{SS}	AB1	IN91N	AC1	IN89N	AD1	IN86N
W2	IN97P	Y2	IN95P	AA2	IN94P	AB2	IN91P	AC2	IN89P	AD2	IN86P
W3	IN97N	Y3	IN96P	AA3	IN92P	AB3	IN90N	AC3	IN88N	AD3	IN85N
W4	IN98P	Y4	IN95N	AA4	IN93N	AB4	IN90P	AC4	IN88P	AD4	IN85P
W5	IN98N	Y5	V _{DD} -CORE	AA5	IN93P	AB5	V _{DD} -CORE	AC5	IN87N	AD5	V _{DD} -CORE
W6	IN99P	Y6	V _{DD} -CORE	AA6	IN92N	AB6	V _{DD} -CORE	AC6	IN87P	AD6	V _{DD} -CORE
W34	IN30N	Y34	V _{DD} -CORE	AA34	IN36P	AB34	V _{DD} -CORE	AC34	IN40N	AD34	V _{DD} -CORE
W35	IN31P	Y35	V _{DD} -CORE	AA35	IN35N	AB35	V _{DD} -CORE	AC35	IN40P	AD35	V _{DD} -CORE
W36	IN31N	Y36	V _{DD} -IN	AA36	IN35P	AB36	IN38P	AC36	IN39N	AD36	IN42N
W37	IN32P	Y37	IN33N	AA37	IN34N	AB37	IN37N	AC37	IN39P	AD37	IN42P
W38	IN32N	Y38	IN33P	AA38	IN34P	AB38	IN37P	AC38	IN38N	AD38	IN41N
W39	V _{SS}	Y39	V _{DD} -IN	AA39	V _{SS}	AB39	IN36N	AC39	V _{SS}	AD39	IN41P



OCX256 Crosspoint Switch—Advanced Data Sheet

Table 22 OCX256 Pinout By Ball Sequence (Continued)

Ball #	Ball Name	Ball #	Ball Name	Ball #	Ball Name	Ball #	Ball Name	Ball #	Ball Name	Ball #	Ball Name
W1	IN96N	Y1	IN94N	AA1	V _{SS}	AB1	IN91N	AC1	IN89N	AD1	IN86N
W2	IN97P	Y2	IN95P	AA2	IN94P	AB2	IN91P	AC2	IN89P	AD2	IN86P
W3	IN97N	Y3	IN96P	AA3	IN92P	AB3	IN90N	AC3	IN88N	AD3	IN85N
W4	IN98P	Y4	IN95N	AA4	IN93N	AB4	IN90P	AC4	IN88P	AD4	IN85P
W5	IN98N	Y5	V _{DD} -CORE	AA5	IN93P	AB5	V _{DD} -CORE	AC5	IN87N	AD5	V _{DD} -CORE
W6	IN99P	Y6	V _{DD} -CORE	AA6	IN92N	AB6	V _{DD} -CORE	AC6	IN87P	AD6	V _{DD} -CORE
W34	IN30N	Y34	V _{DD} -CORE	AA34	IN36P	AB34	V _{DD} -CORE	AC34	IN40N	AD34	V _{DD} -CORE
W35	IN31P	Y35	V _{DD} -CORE	AA35	IN35N	AB35	V _{DD} -CORE	AC35	IN40P	AD35	V _{DD} -CORE
W36	IN31N	Y36	V _{DD} -IN	AA36	IN35P	AB36	IN38P	AC36	IN39N	AD36	IN42N
W37	IN32P	Y37	IN33N	AA37	IN34N	AB37	IN37N	AC37	IN39P	AD37	IN42P
W38	IN32N	Y38	IN33P	AA38	IN34P	AB38	IN37P	AC38	IN38N	AD38	IN41N
W39	V _{SS}	Y39	V _{DD} -IN	AA39	V _{SS}	AB39	IN36N	AC39	V _{SS}	AD39	IN41P

AE1	V _{SS}	AF1	IN82P	AG1	IN79P	AH1	IN78N	AJ1	IN74N	AK1	IN74P
AE2	IN84N	AF2	IN81N	AG2	V _{DD} -IN	AH2	IN78P	AJ2	IN76N	AK2	IN73N
AE3	IN84P	AF3	IN81P	AG3	IN80N	AH3	IN77N	AJ3	IN76P	AK3	IN73P
AE4	IN83N	AF4	V _{DD} -IN	AG4	IN80P	AH4	IN77P	AJ4	IN75N	AK4	IN72N
AE5	IN83P	AF5	V _{DD} -CORE	AG5	IN79N	AH5	V _{DD} -CORE	AJ5	IN75P	AK5	V _{DD} -CORE
AE6	IN82N	AF6	V _{DD} -CORE	AG6	V _{SS}	AH6	V _{DD} -CORE	AJ6	V _{SS}	AK6	V _{DD} -CORE
AE34	IN45P	AF34	V _{DD} -CORE	AG34	IN49N	AH34	V _{DD} -CORE	AJ34	IN54P	AK34	V _{DD} -CORE
AE35	IN44N	AF35	V _{DD} -CORE	AG35	IN49P	AH35	V _{DD} -CORE	AJ35	IN53N	AK35	V _{DD} -CORE
AE36	IN44P	AF36	IN47P	AG36	IN48N	AH36	IN51N	AJ36	IN53P	AK36	IN56P
AE37	IN43N	AF37	IN46N	AG37	IN48P	AH37	IN51P	AJ37	IN52N	AK37	IN55N
AE38	IN43P	AF38	IN46P	AG38	IN47N	AH38	IN50N	AJ38	IN52P	AK38	IN55P
AE39	V _{SS}	AF39	IN45N	AG39	V _{SS}	AH39	IN50P	AJ39	V _{SS}	AK39	IN54N

AL1	IN70P	AM1	IN69N	AN1	V _{SS}
AL2	IN72P	AM2	IN69P	AN2	IN67N
AL3	IN71N	AM3	IN68N	AN3	IN67P
AL4	IN71P	AM4	IN68P	AN4	IN66N
AL5	IN70N	AM5	V _{DD} -CORE	AN5	IN66P
AL6	V _{SS}	AM6	V _{DD} -CORE	AN6	IN64N
AL34	IN58P	AM34	V _{DD} -CORE	AN34	IN63N
AL35	IN57N	AM35	V _{DD} -CORE	AN35	IN63P
AL36	IN57P	AM36	IN60P	AN36	IN62N
AL37	V _{DD} -IN	AM37	IN59N	AN37	IN61N
AL38	V _{DD} -IN	AM38	IN59P	AN38	IN60N
AL39	IN56N	AM39	IN58N	AN39	V _{SS}



Table 22 OCX256 Pinout By Ball Sequence (Continued)

Ball #	Ball Name	Ball #	Ball Name	Ball #	Ball Name	Ball #	Ball Name	Ball #	Ball Name	Ball #	Ball Name
AP1	IN65N	AR1	V _{SS}	AT1	V _{SS}	AU1	V _{SS}	AV1	V _{SS}	AW1	V _{SS}
AP2	IN65P	AR2	V _{DD} -IN	AT2	RCI3	AU2	V _{SS}	AV2	V _{SS}	AW2	V _{SS}
AP3	IN64P	AR3	RC_CLK#	AT3	V _{SS}	AU3	V _{SS}	AV3	V _{SS}	AW3	V _{SS}
AP4	RC_EN#	AR4	V _{SS}	AT4	V _{SS}	AU4	V _{SS}	AV4	RCI2	AW4	V _{SS}
AP5	V _{DD} -CORE	AR5	V _{SS}	AT5	V _{SS}	AU5	RCB6	AV5	RCB4	AW5	OUT126N
AP6	V _{DD} -CORE	AR6	RCI1	AT6	RCI0	AU6	RCB5	AV6	OUT127N	AW6	OUT124P
AP7	OUT127P	AR7	OUT126P	AT7	OUT125N	AU7	OUT125P	AV7	OUT124N	AW7	V _{SS}
AP8	OUT123N	AR8	OUT123P	AT8	OUT122N	AU8	OUT122P	AV8	OUT121N	AW8	OUT121P
AP9	V _{DD} -PAD	AR9	OUT120N	AT9	OUT120P	AU9	OUT119P	AV9	OUT119N	AW9	V _{SS}
AP10	V _{DD} -CORE	AR10	V _{DD} -CORE	AT10	OUT118N	AU10	OUT118P	AV10	OUT117N	AW10	OUT117P
AP11	OUT116N	AR11	OUT116P	AT11	OUT115N	AU11	OUT115P	AV11	V _{SS}	AW11	OUT114N
AP12	V _{DD} -CORE	AR12	V _{DD} -CORE	AT12	OUT114P	AU12	OUT113N	AV12	OUT113P	AW12	OUT112N
AP13	OUT112P	AR13	OUT111N	AT13	OUT111P	AU13	OUT110N	AV13	OUT110P	AW13	V _{SS}
AP14	V _{DD} -CORE	AR14	V _{DD} -CORE	AT14	V _{DD} -PAD	AU14	V _{DD} -PAD	AV14	OUT109N	AW14	OUT109P
AP15	OUT108N	AR15	OUT108P	AT15	OUT107N	AU15	OUT107P	AV15	OUT106N	AW15	OUT106P
AP16	V _{DD} -CORE	AR16	V _{DD} -CORE	AT16	OUT105N	AU16	OUT105P	AV16	OUT104N	AW16	OUT104P
AP17	OUT103N	AR17	OUT103P	AT17	OUT102N	AU17	OUT102P	AV17	OUT101N	AW17	V _{SS}
AP18	V _{DD} -CORE	AR18	V _{DD} -CORE	AT18	OUT101P	AU18	OUT100N	AV18	OUT100P	AW18	OUT99N
AP19	OUT99P	AR19	V _{DD} -PAD	AT19	V _{DD} -PAD	AU19	OUT98N	AV19	OUT98P	AW19	V _{SS}
AP20	V _{DD} -CORE	AR20	V _{DD} -CORE	AT20	OUT97P	AU20	OUT96N	AV20	OUT97N	AW20	OUT96P
AP21	OUT93N	AR21	OUT94P	AT21	OUT94N	AU21	OUT95P	AV21	OUT95N	AW21	V _{SS}
AP22	V _{DD} -CORE	AR22	V _{DD} -CORE	AT22	OUT91N	AU22	OUT92P	AV22	OUT92N	AW22	OUT93P
AP23	OUT88N	AR23	OUT89P	AT23	OUT89N	AU23	OUT90P	AV23	OUT90N	AW23	OUT91P
AP24	V _{DD} -CORE	AR24	V _{DD} -CORE	AT24	OUT86N	AU24	OUT87P	AV24	OUT87N	AW24	OUT88P
AP25	OUT84P	AR25	OUT84N	AT25	OUT85P	AU25	OUT85N	AV25	OUT86P	AW25	V _{SS}
AP26	V _{DD} -CORE	AR26	V _{DD} -CORE	AT26	OUT82P	AU26	OUT82N	AV26	OUT83P	AW26	OUT83N
AP27	V _{DD} -PAD	AR27	V _{DD} -PAD	AT27	OUT80P	AU27	OUT80N	AV27	OUT81P	AW27	OUT81N
AP28	V _{DD} -CORE	AR28	V _{DD} -CORE	AT28	OUT78P	AU28	OUT78N	AV28	OUT79P	AW28	OUT79N
AP29	OUT75N	AR29	OUT76P	AT29	OUT76N	AU29	OUT77P	AV29	OUT77N	AW29	V _{SS}
AP30	OUT72N	AR30	OUT73P	AT30	OUT73N	AU30	OUT74P	AV30	OUT74N	AW30	OUT75P
AP31	OUT70P	AR31	OUT70N	AT31	OUT71P	AU31	OUT71N	AV31	OUT72P	AW31	V _{SS}
AP32	V _{DD} -CORE	AR32	V _{DD} -CORE	AT32	NC	AU32	OUT68N	AV32	OUT69P	AW32	OUT69N
AP33	OUT65P	AR33	OUT65N	AT33	OUT67P	AU33	OUT66N	AV33	OUT67N	AW33	V _{SS}
AP34	V _{DD} -CORE	AR34	RCB2	AT34	V _{DD} -PAD	AU34	OUT64P	AV34	OUT66P	AW34	OUT68P
AP35	V _{DD} -CORE	AR35	V _{SS}	AT35	V _{SS}	AU35	RCB1	AV35	RCB3	AW35	OUT64N
AP36	RCA6	AR36	V _{SS}	AT36	V _{SS}	AU36	V _{SS}	AV36	V _{SS}	AW36	V _{SS}
AP37	RCA3	AR37	RCB0	AT37	V _{SS}	AU37	V _{SS}	AV37	V _{SS}	AW37	V _{SS}
AP38	RCA2	AR38	RCA4	AT38	RCA5	AU38	V _{SS}	AV38	V _{SS}	AW38	V _{SS}
AP39	IN61P	AR39	IN62P	AT39	V _{SS}	AU39	V _{SS}	AV39	V _{SS}	AW39	V _{SS}



5.3 Pinout by Ball Name

Table 23 OCX256 Pinout By Ball Name

Ball Name	Ball #	Ball Name	Ball #	Ball Name	Ball #	Ball Name	Ball #	Ball Name	Ball #
CLKN	F35	IN21P	R34	IN44P	AE36	IN67P	AN3	IN90P	AB4
CLKP	E37	IN22N	R37	IN45N	AF39	IN68N	AM3	IN91N	AB1
HW_RST#	E6	IN22P	R36	IN45P	AE34	IN68P	AM4	IN91P	AB2
IN00N	F38	IN23N	R39	IN46N	AF37	IN69N	AM1	IN92N	AA6
IN00P	D38	IN23P	R38	IN46P	AF38	IN69P	AM2	IN92P	AA3
IN01N	G35	IN24N	T37	IN47N	AG38	IN70N	AL5	IN93N	AA4
IN01P	E38	IN24P	T36	IN47P	AF36	IN70P	AL1	IN93P	AA5
IN02N	G37	IN25N	T39	IN48N	AG36	IN71N	AL3	IN94N	Y1
IN02P	G34	IN25P	T38	IN48P	AG37	IN71P	AL4	IN94P	AA2
IN03N	F39	IN26N	U35	IN49N	AG34	IN72N	AK4	IN95N	Y4
IN03P	E39	IN26P	U34	IN49P	AG35	IN72P	AL2	IN95P	Y2
IN04N	H36	IN27N	U37	IN50N	AH38	IN73N	AK2	IN96N	W1
IN04P	G38	IN27P	U36	IN50P	AH39	IN73P	AK3	IN96P	Y3
IN05N	H37	IN28N	V36	IN51N	AH36	IN74N	AJ1	IN97N	W3
IN05P	G39	IN28P	U38	IN51P	AH37	IN74P	AK1	IN97P	W2
IN06N	H39	IN29N	V38	IN52N	AJ37	IN75N	AJ4	IN98N	W5
IN06P	H38	IN29P	V37	IN52P	AJ38	IN75P	AJ5	IN98P	W4
IN07N	J35	IN30N	W34	IN53N	AJ35	IN76N	AJ2	IN99N	V1
IN07P	J34	IN30P	V39	IN53P	AJ36	IN76P	AJ3	IN99P	W6
IN08N	J37	IN31N	W36	IN54N	AK39	IN77N	AH3	IN100N	U2
IN08P	J36	IN31P	W35	IN54P	AJ34	IN77P	AH4	IN100P	V4
IN09N	K34	IN32N	W38	IN55N	AK37	IN78N	AH1	IN101N	U4
IN09P	J38	IN32P	W37	IN55P	AK38	IN78P	AH2	IN101P	U3
IN10N	K36	IN33N	Y37	IN56N	AL39	IN79N	AG5	IN102N	U6
IN10P	K35	IN33P	Y38	IN56P	AK36	IN79P	AG1	IN102P	U5
IN11N	K38	IN34N	AA37	IN57N	AL35	IN80N	AG3	IN103N	T2
IN11P	K37	IN34P	AA38	IN57P	AL36	IN80P	AG4	IN103P	T1
IN12N	L34	IN35N	AA35	IN58N	AM39	IN81N	AF2	IN104N	T4
IN12P	K39	IN35P	AA36	IN58P	AL34	IN81P	AF3	IN104P	T3
IN13N	L36	IN36N	AB39	IN59N	AM37	IN82N	AE6	IN105N	R3
IN13P	L35	IN36P	AA34	IN59P	AM38	IN82P	AF1	IN105P	R2
IN14N	L38	IN37N	AB37	IN60N	AN38	IN83N	AE4	IN106N	R5
IN14P	L37	IN37P	AB38	IN60P	AM36	IN83P	AE5	IN106P	R4
IN15N	M38	IN38N	AC38	IN61N	AN37	IN84N	AE2	IN107N	P1
IN15P	M37	IN38P	AB36	IN61P	AP39	IN84P	AE3	IN107P	R6
IN16N	N34	IN39N	AC36	IN62N	AN36	IN85N	AD3	IN108N	P3
IN16P	M39	IN39P	AC37	IN62P	AR39	IN85P	AD4	IN108P	P2
IN17N	N36	IN40N	AC34	IN63N	AN34	IN86N	AD1	IN109N	N2
IN17P	N35	IN40P	AC35	IN63P	AN35	IN86P	AD2	IN109P	P4
IN18N	N38	IN41N	AD38	IN64N	AN6	IN87N	AC5	IN110N	N4
IN18P	N37	IN41P	AD39	IN64P	AP3	IN87P	AC6	IN110P	N3
IN19N	P37	IN42N	AD36	IN65N	AP1	IN88N	AC3	IN111N	M2
IN19P	P36	IN42P	AD37	IN65P	AP2	IN88P	AC4	IN111P	M1
IN20N	P39	IN43N	AE37	IN66N	AN4	IN89N	AC1	IN112N	M4
IN20P	P38	IN43P	AE38	IN66P	AN5	IN89P	AC2	IN112P	M3
IN21N	R35	IN44N	AE35	IN67N	AN2	IN90N	AB3	IN113N	M6



Table 23 OCX256 Pinout By Ball Name (Continued)

Ball Name	Ball #	Ball Name	Ball #	Ball Name	Ball #	Ball Name	Ball #	Ball Name	Ball #
IN113P	M5	OUT07N	D9	OUT30P	E19	OUT54N	A30	OUT77P	AU29
IN114N	L2	OUT07P	E9	OUT31N	B19	OUT54P	F29	OUT78N	AU28
IN114P	L1	OUT08N	B9	OUT31P	C19	OUT55N	C30	OUT78P	AT28
IN115N	L4	OUT08P	C9	OUT32N	D20	OUT55P	B30	OUT79N	AW28
IN115P	L3	OUT09N	D10	OUT32P	B20	OUT56N	C31	OUT79P	AV28
IN116N	L6	OUT09P	A9	OUT33N	A20	OUT56P	B31	OUT80N	AU27
IN116P	L5	OUT10N	B10	OUT33P	C20	OUT57N	E31	OUT80P	AT27
IN117N	K2	OUT10P	C10	OUT34N	E21	OUT57P	D31	OUT81N	AW27
IN117P	K1	OUT11N	F11	OUT34P	D21	OUT58N	A32	OUT81P	AV27
IN118N	K4	OUT11P	A10	OUT35N	A22	OUT58P	F31	OUT82N	AU26
IN118P	K3	OUT12N	D11	OUT35P	F21	OUT59N	C32	OUT82P	AT26
IN119N	K5	OUT12P	E11	OUT36N	C22	OUT59P	B32	OUT83N	AW26
IN119P	K6	OUT13N	C12	OUT36P	B22	OUT60N	B33	OUT83P	AV26
IN120N	J3	OUT13P	D12	OUT37N	A23	OUT60P	D32	OUT84N	AR25
IN120P	J2	OUT14N	A12	OUT37P	D22	OUT61N	A34	OUT84P	AP25
IN121N	H1	OUT14P	B12	OUT38N	C23	OUT61P	C33	OUT85N	AU25
IN121P	J6	OUT15N	E13	OUT38P	B23	OUT62N	E33	OUT85P	AT25
IN122N	H3	OUT15P	F13	OUT39N	E23	OUT62P	D33	OUT86N	AT24
IN122P	H2	OUT16N	C13	OUT39P	D23	OUT63N	B35	OUT86P	AV25
IN123N	G2	OUT16P	D13	OUT40N	A24	OUT63P	B34	OUT87N	AV24
IN123P	H4	OUT17N	A13	OUT40P	F23	OUT64N	AW35	OUT87P	AU24
IN124N	F1	OUT17P	B13	OUT41N	C24	OUT64P	AU34	OUT88N	AP23
IN124P	G3	OUT18N	C14	OUT41P	B24	OUT65N	AR33	OUT88P	AW24
IN125N	G5	OUT18P	D14	OUT42N	B25	OUT65P	AP33	OUT89N	AT23
IN125P	G4	OUT19N	A14	OUT42P	D24	OUT66N	AU33	OUT89P	AR23
IN126N	G6	OUT19P	B14	OUT43N	D25	OUT66P	AV34	OUT90N	AV23
IN126P	F2	OUT20N	E15	OUT43P	C25	OUT67N	AV33	OUT90P	AU23
IN127N	F3	OUT20P	F15	OUT44N	F25	OUT67P	AT33	OUT91N	AT22
IN127P	E1	OUT21N	C15	OUT44P	E25	OUT68N	AU32	OUT91P	AW23
NC	E34	OUT21P	D15	OUT45N	B26	OUT68P	AW34	OUT92N	AV22
NC	D2	OUT22N	D16	OUT45P	A26	OUT69N	AW32	OUT92P	AU22
NC	AT32	OUT22P	B15	OUT46N	D26	OUT69P	AV32	OUT93N	AP21
OE#	D34	OUT23N	B16	OUT46P	C26	OUT70N	AR31	OUT93P	AW22
OUT00N	C6	OUT23P	C16	OUT47N	B27	OUT70P	AP31	OUT94N	AT21
OUT00P	F7	OUT24N	F17	OUT47P	A27	OUT71N	AU31	OUT94P	AR21
OUT01N	A5	OUT24P	A16	OUT48N	D27	OUT71P	AT31	OUT95N	AV21
OUT01P	E7	OUT25N	D17	OUT48P	C27	OUT72N	AP30	OUT95P	AU21
OUT02N	B6	OUT25P	E17	OUT49N	F27	OUT72P	AV31	OUT96N	AU20
OUT02P	D7	OUT26N	B17	OUT49P	E27	OUT73N	AT30	OUT96P	AW20
OUT03N	C7	OUT26P	C17	OUT50N	B28	OUT73P	AR30	OUT97N	AV20
OUT03P	A6	OUT27N	D18	OUT50P	A28	OUT74N	AV30	OUT97P	AT20
OUT04N	D8	OUT27P	A17	OUT51N	D28	OUT74P	AU30	OUT98N	AU19
OUT04P	B7	OUT28N	B18	OUT51P	C28	OUT75N	AP29	OUT98P	AV19
OUT05N	B8	OUT28P	C18	OUT52N	C29	OUT75P	AW30	OUT99N	AW18
OUT05P	C8	OUT29N	F19	OUT52P	B29	OUT76N	AT29	OUT99P	AP19
OUT06N	F9	OUT29P	A18	OUT53N	E29	OUT76P	AR29	OUT100N	AU18
OUT06P	A8	OUT30N	D19	OUT53P	D29	OUT77N	AV29	OUT100P	AV18



OCX256 Crosspoint Switch—Advanced Data Sheet

Table 23 OCX256 Pinout By Ball Name (Continued)

Ball Name	Ball #	Ball Name	Ball #	Ball Name	Ball #	Ball Name	Ball #	Ball Name	Ball #
OUT101N	AV17	OUT124P	AW6	V _{DD} .CORE	E26	V _{DD} .CORE	AD34	V _{DD} .IN	J4
OUT101P	AT18	OUT125N	AT7	V _{DD} .CORE	E28	V _{DD} .CORE	AD35	V _{DD} .IN	J5
OUT102N	AT17	OUT125P	AU7	V _{DD} .CORE	E30	V _{DD} .CORE	AF5	V _{DD} .IN	L39
OUT102P	AU17	OUT126N	AW5	V _{DD} .CORE	E32	V _{DD} .CORE	AF6	V _{DD} .IN	M36
OUT103N	AP17	OUT126P	AR7	V _{DD} .CORE	F6	V _{DD} .CORE	AF34	V _{DD} .IN	V2
OUT103P	AR17	OUT127N	AV6	V _{DD} .CORE	F8	V _{DD} .CORE	AF35	V _{DD} .IN	V3
OUT104N	AV16	OUT127P	AP7	V _{DD} .CORE	F10	V _{DD} .CORE	AH5	V _{DD} .IN	Y36
OUT104P	AW16	RCA0	F36	V _{DD} .CORE	F12	V _{DD} .CORE	AH6	V _{DD} .IN	Y39
OUT105N	AT16	RCA1	F37	V _{DD} .CORE	F14	V _{DD} .CORE	AH34	V _{DD} .IN	AF4
OUT105P	AU16	RCA2	AP38	V _{DD} .CORE	F16	V _{DD} .CORE	AH35	V _{DD} .IN	AG2
OUT106N	AV15	RCA3	AP37	V _{DD} .CORE	F18	V _{DD} .CORE	AK5	V _{DD} .IN	AL37
OUT106P	AW15	RCA4	AR38	V _{DD} .CORE	F20	V _{DD} .CORE	AK6	V _{DD} .IN	AL38
OUT107N	AT15	RCA5	AT38	V _{DD} .CORE	F22	V _{DD} .CORE	AK34	V _{DD} .IN	AR2
OUT107P	AU15	RCA6	AP36	V _{DD} .CORE	F24	V _{DD} .CORE	AK35	V _{DD} .PAD	A31
OUT108N	AP15	RCB0	AR37	V _{DD} .CORE	F26	V _{DD} .CORE	AM5	V _{DD} .PAD	B5
OUT108P	AR15	RCB1	AU35	V _{DD} .CORE	F28	V _{DD} .CORE	AM6	V _{DD} .PAD	B11
OUT109N	AV14	RCB2	AR34	V _{DD} .CORE	F30	V _{DD} .CORE	AM34	V _{DD} .PAD	B21
OUT109P	AW14	RCB3	AV35	V _{DD} .CORE	F32	V _{DD} .CORE	AM35	V _{DD} .PAD	C11
OUT110N	AU13	RCB4	AV5	V _{DD} .CORE	F34	V _{DD} .CORE	AP5	V _{DD} .PAD	C21
OUT110P	AV13	RCB5	AU6	V _{DD} .CORE	H5	V _{DD} .CORE	AP6	V _{DD} .PAD	D30
OUT111N	AR13	RCB6	AU5	V _{DD} .CORE	H6	V _{DD} .CORE	AP10	V _{DD} .PAD	AP9
OUT111P	AT13	RC_CLK#	AR3	V _{DD} .CORE	H34	V _{DD} .CORE	AP12	V _{DD} .PAD	AP27
OUT112N	AW12	RC_EN#	AP4	V _{DD} .CORE	H35	V _{DD} .CORE	AP14	V _{DD} .PAD	AR19
OUT112P	AP13	RCI0	AT6	V _{DD} .CORE	M34	V _{DD} .CORE	AP16	V _{DD} .PAD	AR27
OUT113N	AU12	RCI1	AR6	V _{DD} .CORE	M35	V _{DD} .CORE	AP18	V _{DD} .PAD	AT14
OUT113P	AV12	RCI2	AV4	V _{DD} .CORE	P5	V _{DD} .CORE	AP20	V _{DD} .PAD	AT19
OUT114N	AW11	RCI3	AT2	V _{DD} .CORE	P6	V _{DD} .CORE	AP22	V _{DD} .PAD	AT34
OUT114P	AT12	RCO0	F33	V _{DD} .CORE	P34	V _{DD} .CORE	AP24	V _{DD} .PAD	AU14
OUT115N	AT11	RCO1	B36	V _{DD} .CORE	P35	V _{DD} .CORE	AP26	V _{SS}	A1
OUT115P	AU11	RCO2	C34	V _{DD} .CORE	T5	V _{DD} .CORE	AP28	V _{SS}	A2
OUT116N	AP11	RCO3	C35	V _{DD} .CORE	T6	V _{DD} .CORE	AP32	V _{SS}	A3
OUT116P	AR11	RCO4	D6	V _{DD} .CORE	T34	V _{DD} .CORE	AP34	V _{SS}	A4
OUT117N	AV10	TCK	F5	V _{DD} .CORE	T35	V _{DD} .CORE	AP35	V _{SS}	A7
OUT117P	AW10	TDI	E2	V _{DD} .CORE	V5	V _{DD} .CORE	AR10	V _{SS}	A11
OUT118N	AT10	TDO	C5	V _{DD} .CORE	V6	V _{DD} .CORE	AR12	V _{SS}	A15
OUT118P	AU10	TMS	F4	V _{DD} .CORE	V34	V _{DD} .CORE	AR14	V _{SS}	A19
OUT119N	AU9	TRST#	E3	V _{DD} .CORE	V35	V _{DD} .CORE	AR16	V _{SS}	A21
OUT119P	AV9	UPDATE#	B4	V _{DD} .CORE	Y5	V _{DD} .CORE	AR18	V _{SS}	A25
OUT120N	AR9	V _{DD} .CORE	E8	V _{DD} .CORE	Y6	V _{DD} .CORE	AR20	V _{SS}	A29
OUT120P	AT9	V _{DD} .CORE	E10	V _{DD} .CORE	Y34	V _{DD} .CORE	AR22	V _{SS}	A33
OUT121N	AV8	V _{DD} .CORE	E12	V _{DD} .CORE	Y35	V _{DD} .CORE	AR24	V _{SS}	A35
OUT121P	AW8	V _{DD} .CORE	E14	V _{DD} .CORE	AB5	V _{DD} .CORE	AR26	V _{SS}	A36
OUT122N	AT8	V _{DD} .CORE	E16	V _{DD} .CORE	AB6	V _{DD} .CORE	AR28	V _{SS}	A37
OUT122P	AU8	V _{DD} .CORE	E18	V _{DD} .CORE	AB34	V _{DD} .CORE	AR32	V _{SS}	A38
OUT123N	AP8	V _{DD} .CORE	E20	V _{DD} .CORE	AB35	V _{DD} .IN	N6	V _{SS}	A39
OUT123P	AR8	V _{DD} .CORE	E22	V _{DD} .CORE	AD5	V _{DD} .IN	N5	V _{SS}	B1
OUT124N	AV7	V _{DD} .CORE	E24	V _{DD} .CORE	AD6	V _{DD} .IN	G36	V _{SS}	B2

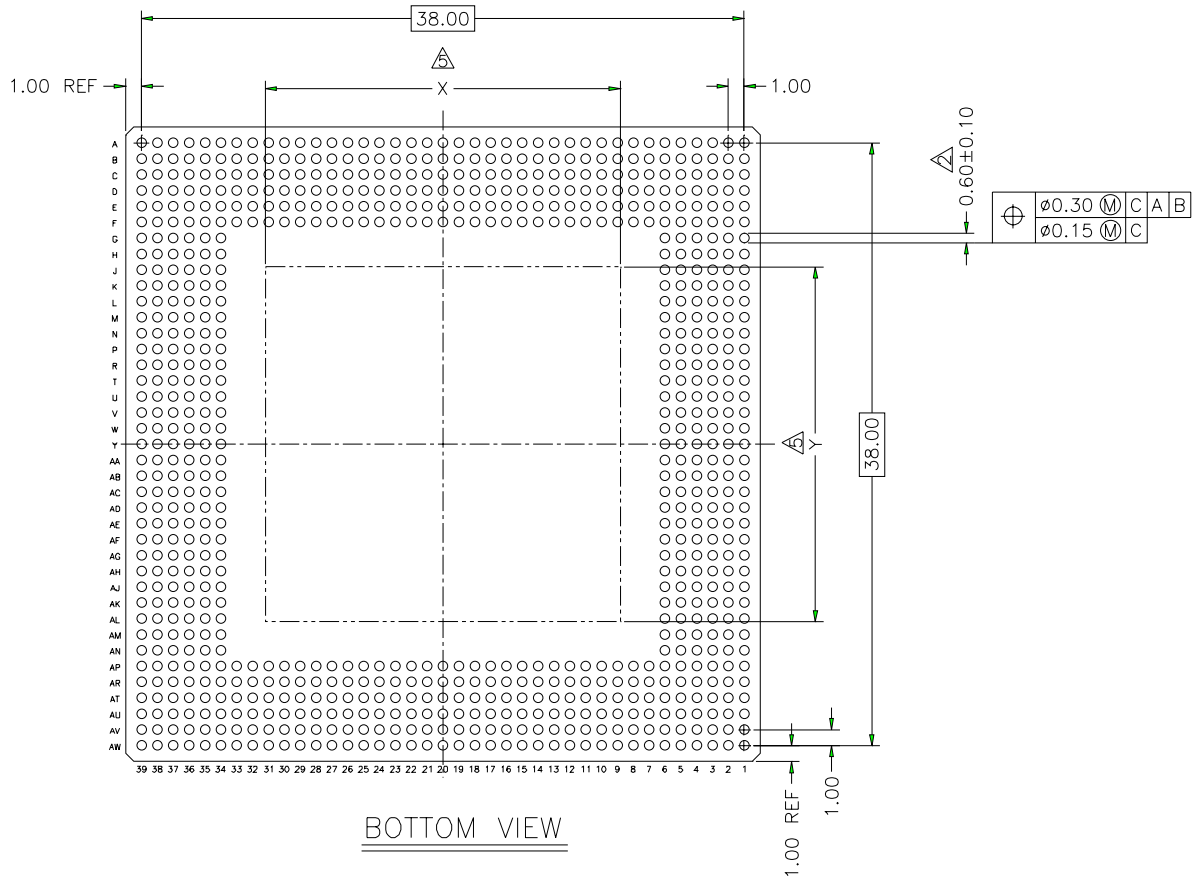

Table 23 OCX256 Pinout By Ball Name (Continued)

Ball Name	Ball #	Ball Name	Ball #	Ball Name	Ball #	Ball Name	Ball #	Ball Name	Ball #
V _{SS}	B3	V _{SS}	AR5						
V _{SS}	B37	V _{SS}	AR35						
V _{SS}	B38	V _{SS}	AR36						
V _{SS}	B39	V _{SS}	AT1						
V _{SS}	C1	V _{SS}	AT3						
V _{SS}	C2	V _{SS}	AT4						
V _{SS}	C3	V _{SS}	AT5						
V _{SS}	C4	V _{SS}	AT35						
V _{SS}	C36	V _{SS}	AT36						
V _{SS}	C37	V _{SS}	AT37						
V _{SS}	C38	V _{SS}	AT39						
V _{SS}	C39	V _{SS}	AU1						
V _{SS}	D1	V _{SS}	AU2						
V _{SS}	D3	V _{SS}	AU3						
V _{SS}	D4	V _{SS}	AU4						
V _{SS}	D5	V _{SS}	AU36						
V _{SS}	D35	V _{SS}	AU37						
V _{SS}	D36	V _{SS}	AU38						
V _{SS}	D37	V _{SS}	AU39						
V _{SS}	D39	V _{SS}	AV1						
V _{SS}	E4	V _{SS}	AV2						
V _{SS}	E5	V _{SS}	AV3						
V _{SS}	E35	V _{SS}	AV11						
V _{SS}	E36	V _{SS}	AV36						
V _{SS}	G1	V _{SS}	AV37						
V _{SS}	J1	V _{SS}	AV38						
V _{SS}	J39	V _{SS}	AV39						
V _{SS}	N1	V _{SS}	AW1						
V _{SS}	N39	V _{SS}	AW2						
V _{SS}	R1	V _{SS}	AW3						
V _{SS}	U1	V _{SS}	AW4						
V _{SS}	U39	V _{SS}	AW7						
V _{SS}	W39	V _{SS}	AW9						
V _{SS}	AA1	V _{SS}	AW13						
V _{SS}	AA39	V _{SS}	AW17						
V _{SS}	AC39	V _{SS}	AW19						
V _{SS}	AE1	V _{SS}	AW21						
V _{SS}	AE39	V _{SS}	AW25						
V _{SS}	AG6	V _{SS}	AW29						
V _{SS}	AG39	V _{SS}	AW31						
V _{SS}	AJ6	V _{SS}	AW33						
V _{SS}	AJ39	V _{SS}	AW36						
V _{SS}	AL6	V _{SS}	AW37						
V _{SS}	AN1	V _{SS}	AW38						
V _{SS}	AN39	V _{SS}	AW39						
V _{SS}	AR1								
V _{SS}	AR4								



5.4 Package Dimensions



NOTE

1. DIMENSIONS AND TOLERANCE PER ASME Y 14.5M - 1994
- ▲ DIMENSION IS MEASURED AT THE MAXIMUM SOLDER BALL DIAMETER PARALLEL TO PRIMARY DATUM C
- ▲ PRIMARY DATUM C AND SEATING PLANE ARE DEFINED BY THE SPHERICAL CROWNS OF THE SOLDER BALLS.
4. SOLDER BALL POSITION DESIGNATION PER JESD 95-1.
- ▲ THE ENCAPSULATION SIZE (X,Y) WILL VARY WITH CAVITY SIZE, THE DISTANCE FROM BOND FINGER EDGE TO ENCAPSULATION SHALL BE MIN. 0.50MM.
6. UNLESS OTHERWISE SPECIFIED TOLERANCE : DECIMAL ± 0.05
ANGULAR $\pm 2^\circ$.

Figure 21 OCX256 Package—Bottom View

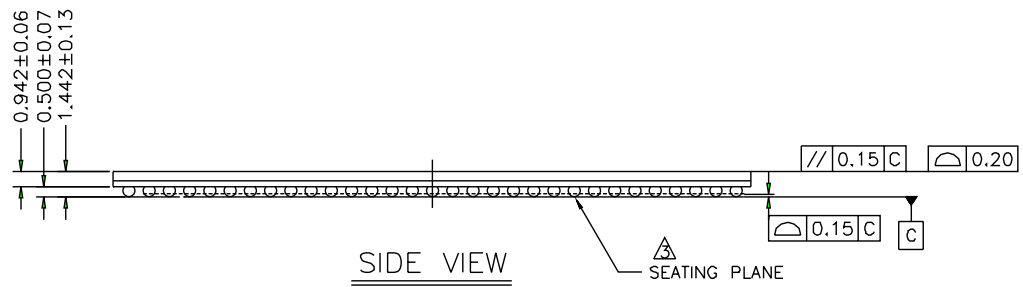
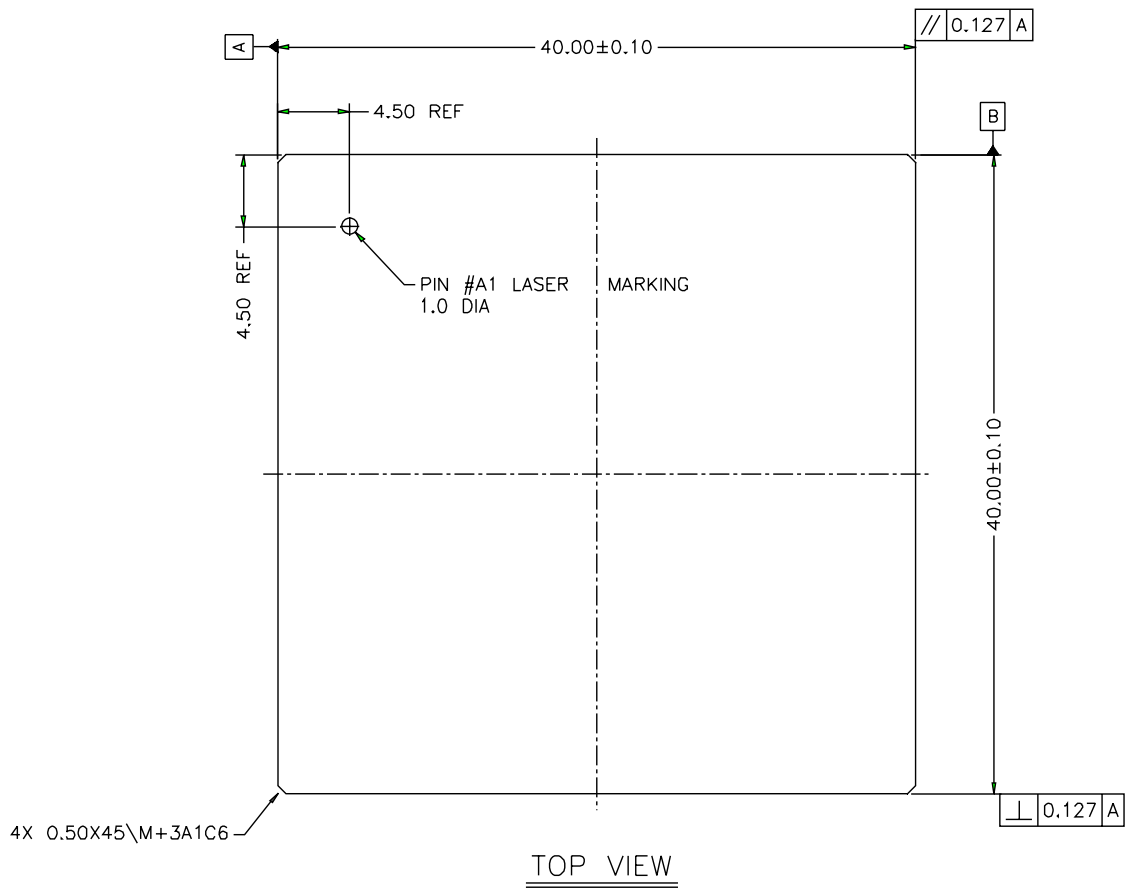

Figure 22 OCX256 Package—Top and Side Views



5.5 Package Thermal Characteristics

Table 24 Package Thermal Coefficients

Package	Pin Count	$\Theta_{JC}(C/W)$	$\Theta_{JA}(^{\circ}C/W)$ Still Air
TBGA	792	0.4	7.58 $^{\circ}C/W$

NOTE:

1. Thermal performance values are based on simulation data.



6. Power Consumption

There are two main factors to consider when calculating power consumption for the OCX256:

- Power consumed by the chip
- Power dissipated by the terminating resistors at the switch differential outputs

The first component, chip power, consists of three integral elements (refer to Figure 23):

1. **Input Power**—This element is fixed (always ON) due to the DC current for differential outputs.
2. **Core Power**—This element is the same for LVDS or LVPECL outputs. Core power is a function of data rate (Mb/s) and the number of connection paths through the switch matrix.
3. **Output Power**—This element is a fixed amount for each differential output. The value is zero if the Output Enable (OE#) is disabled or set to OFF.

The second component, termination power, is the power dissipated by the terminating resistors at the switch differential outputs. The value is zero if the Output Enable (OE#) is disabled or set to OFF.

The following diagram shows the chip power elements (as described above), the formulas used for determining chip power, and the total power consumption as determined by the formula [**Chip Power + Termination Power**].

6.1 Power for LVDS I/O

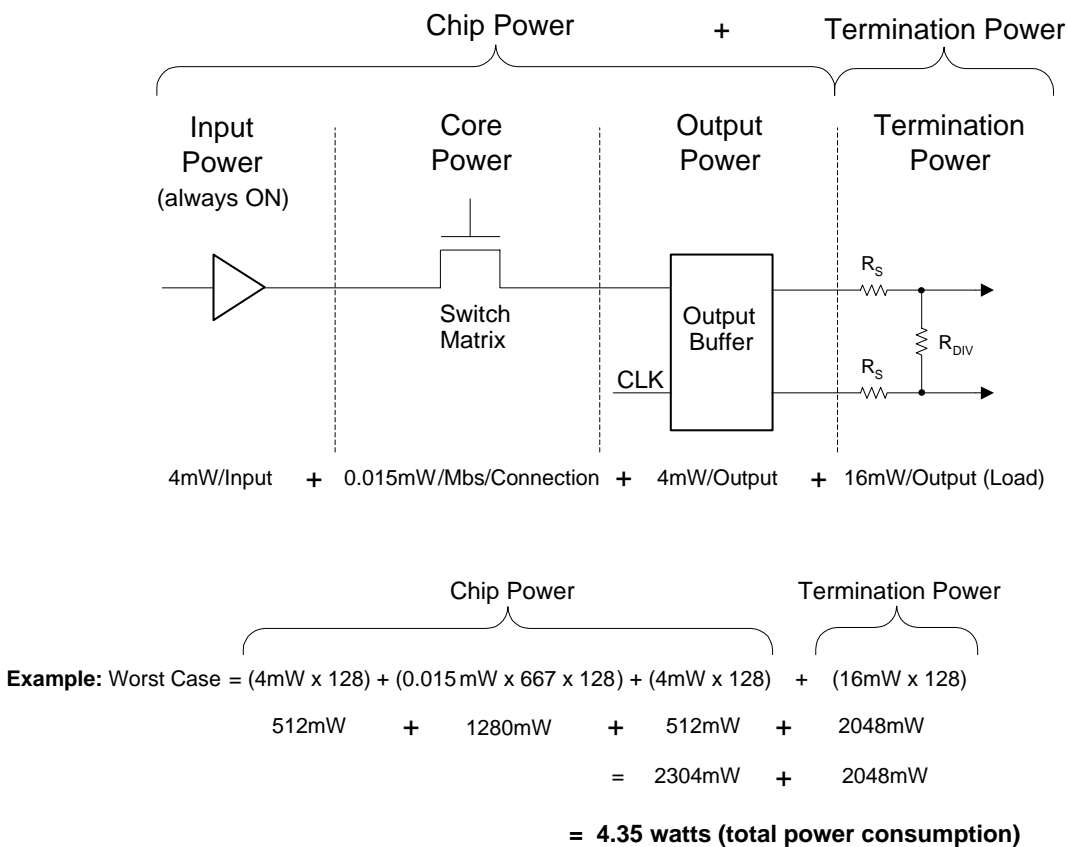

Figure 23 Power Consumption Diagram for the OCX256 using LVDS



6.2 Power for LVPECL I/O

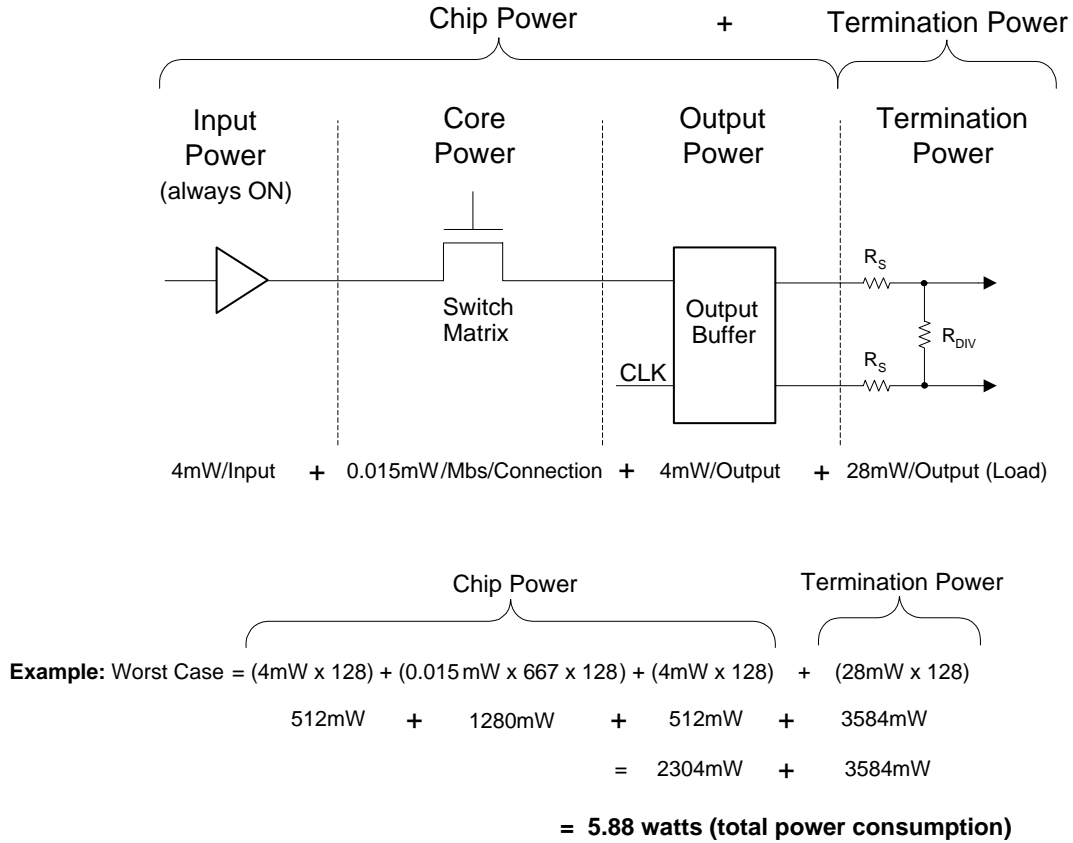
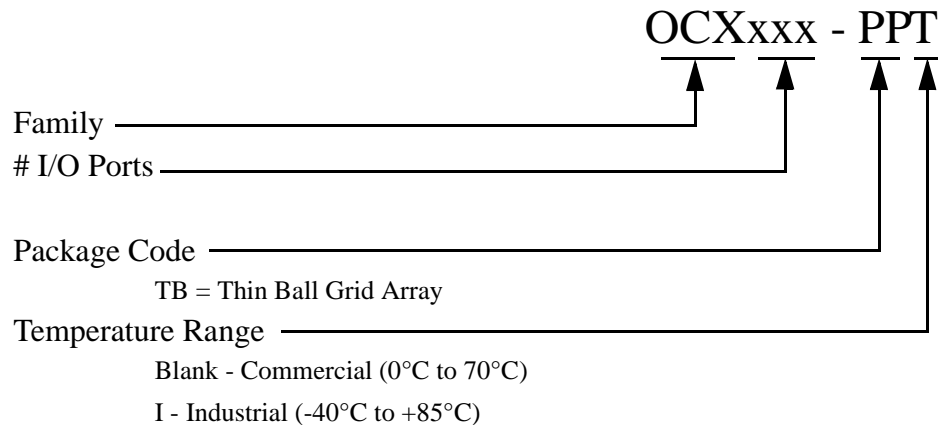

Figure 24 Power Consumption Diagram for the OCX256 using LVPECL



7. Component Availability and Ordering Information



8. Glossary

CLOCK: A single differential input used to gate data into registers in the Output Buffer. The input serves all outputs of the OCX. The neighbor input can also be used as a register clock.

CROSSPOINT: A single cell controlled by two RAM bits. The RAM bits are connected in a master-slave configuration to provide an update for programming and changing program information all at once.

CROSSPOINT ARRAY: An array of Crosspoint cells used to connect any input port to any output port.

INPUT OR OUTPUT PATH: The signal flow from pin to array and array to pin. Each path has a register with selectable clocks, drivers for the loaded outputs with selectable enables, and sense circuits to detect changes on either side of the IO Buffer.

NEXT NEIGHBOR: A physically adjacent port can be used as a clock source for an output configured in registered mode. These outputs are grouped in pairs such that the signal being switched through Output 0 can be used to clock the signal being switched through Output 1, or vice-versa. Any single clock or data input signal can be used to clock any other input signal provided they are switched to an appropriate output pair.

PORT: A name followed by a number to identify a pin on the device.

RAPIDCONFIGURE: A parallel programming method for the OCX devices. The RC mode uses 25 dedicated pins to program the Crosspoint Array and the IO Buffers. The 25 pins consist of an enable, a clock, four instruction bits, two seven-bit address fields, and a five-bit data field.



Revision History

Date	Version No.	Description														
9/25/2000	Revision 1.0	Preliminary release of “Advanced” data sheet														
10/8/00	Revision 1.1	Additions include RCO output pin information, pinout drawing, pinout tables, package dimensions and illustration, duty-cycle diagram, thermal characteristics table, device reset options table, a section on configuring multiple devices, bitstream generation and downloading, JTAG information, and Power Consumption information/illustrations.														
11/1/00	Revision 1.2	Corrections made to pinout drawing and pin names.														
11/16/00	Revision 1.3	Updated RapidConfigure Read Cycle timing diagram so that RCO is relative to RC_CLK#; RCO was previously relative to RC_EN#. Replaced “+” on signal names to “P” and “-” to “N”. Corrected RCO[4:0] pin locations.														
11/21/00	Revision 1.4	Corrected pin names ENAB, RCC, and RCE on Pinout drawing and tables to be OE#, RC_CLK#, and RC_EN# respectively; corrections to Input and Output pin names 59P, 60P, 61P, and 62P in tables 22 and 23.														
1/12/01	Revision 1.5	Corrected pin names in Table 22 “Pinout By Ball Sequence”: <table><thead><tr><th><u>From</u></th><th><u>To</u></th></tr></thead><tbody><tr><td>B32 OUT58P</td><td>B32 OUT59P</td></tr><tr><td>C33 OUT60P</td><td>C33 OUT61P</td></tr><tr><td>D32 OUT59P</td><td>D32 OUT60P</td></tr><tr><td>D33 OUT61P</td><td>D33 OUT62P</td></tr><tr><td>AR9 OUT120P</td><td>AR9 OUT120N</td></tr><tr><td>AT9 OUT120N</td><td>AT9 OUT120P</td></tr></tbody></table>	<u>From</u>	<u>To</u>	B32 OUT58P	B32 OUT59P	C33 OUT60P	C33 OUT61P	D32 OUT59P	D32 OUT60P	D33 OUT61P	D33 OUT62P	AR9 OUT120P	AR9 OUT120N	AT9 OUT120N	AT9 OUT120P
<u>From</u>	<u>To</u>															
B32 OUT58P	B32 OUT59P															
C33 OUT60P	C33 OUT61P															
D32 OUT59P	D32 OUT60P															
D33 OUT61P	D33 OUT62P															
AR9 OUT120P	AR9 OUT120N															
AT9 OUT120N	AT9 OUT120P															



9. Product Status Definition

Data Sheet Identification	Product Status	Definition
Advanced	Formative or In Design	This data sheet contains the design specifications for product development. Specification may change in any manner without notice.
Preliminary	Preproduction Product	This data sheet contains the preliminary data, and supplementary data will be published at a later date. I-Cube reserves the right to make changes at any time without notice in order to improve design and supply the best possible product.
No Identification	Full Production	This data sheet contains final specifications. I-Cube reserves the right to make changes at any time without notice in order to improve design and supply the best possible product.
Obsolete	No longer in Production	This data sheet contains specifications for a product that has been discontinued by I-Cube. The data sheet is provided for reference information only.

I-Cube® is a registered trademark and RapidConnect, RapidConfigure, ActiveArray, ImpliedDisconnect, IQ, IQX, MSX, MSXPro, OCX, OCXPro, and PSX are trademarks of I-Cube, Inc. All other trademarks or registered trademarks are the property of their respective holders. I-Cube, Inc., does not assume any liability arising out of the applications or use of the product described herein; nor does it convey any license under its patents, copyright rights or any rights of others.

The information contained in this document is believed to be current and accurate as of the publication date. I-Cube reserves the right to make changes, at any time, in order to improve reliability, function, performance or design in order to supply the best product possible.

I-Cube assumes no obligation to correct any errors contained herein or to advise any user of this text of any correction if such be made.

This product is protected under the U.S. patents: 5202593, 5282271, 5426738, 5428750, 5428800, 5465056, 5530814, 5559971, 5625780, 5710550, 5717871, 5734334, 5781717, 5790048. Additional patents pending.

OCX256 Crosspoint Switch Data Sheet— Rev 1.5, January 2001

Copyright © 1992-2001 I-Cube, Inc. All rights reserved. Unpublished—rights reserved under the copyright laws of the United States. Use of copyright notices is precautionary and does not imply publication or disclosure.

I-Cube® , Inc.

2605 S. Winchester Blvd.
Campbell, CA 95008 USA

Phone: +(408) 341-1888
Fax: +(408) 341-1899
Email: marketing@icube.com
Internet: http://www.icube.com

OCX256 Crosspoint Switch Data Sheet
Revision 1.5, January 2001
Document#: MKT-OCX256-DS_Rev+1+dot+5