

<b>NOTICE OF REVISION (NOR)</b> (See MIL-STD-480 for instructions) This revision described below has been authorized for the document listed.		<b>DATE (YYMMDD)</b> 91-11-06	Form Approved OMB No. 0704-0188
Public reporting burden for this collection is estimated to average 1 hour per response, including the time for reviewing instructions, searching existing data sources, gathering and maintaining the data needed, and completing and reviewing the collection of information. Send comments regarding this burden estimate or any other aspect of this collection of information, including suggestions for reducing this burden, to Washington Headquarters Services, Directorate for Information Operations and Reports, 1215 Jefferson Davis Highway, Suite 1204, Arlington, VA 22202-4302, and to the Office of Information and Regulatory Affairs, Office of Management and Budget, Washington, DC 20503.			
<b>1. ORIGINATOR NAME AND ADDRESS</b> Defense Electronics Supply Center Dayton, Ohio 45444-5277		<b>2. CAGE CODE</b> 67268	<b>3. NOR NO.</b> 5962-R034-92
		<b>4. CAGE CODE</b> 67268	<b>5. DOCUMENT NO.</b> 5962-89592
<b>6. TITLE OF DOCUMENT</b> <b>MICROCIRCUIT, DIGITAL, LOW POWER, SINGLE CHANNEL, DRIVER-RECEIVER, HYBRID</b>		<b>7. REVISION LETTER</b> (Current) A	(New) B
		<b>8. ECP NO.</b>	
<b>9. CONFIGURATION ITEM (OR SYSTEM) TO WHICH ECP APPLIES</b> ALL			
<b>10. DESCRIPTION OF REVISION</b> Sheet 1: Revisions ltr column; add "B" Revisions description column; add "Changes in accordance with NOR 5962-R034-92". Revisions date column; add "91-11-06". Sheet 7: Table I, Add subgroup 5 to the I <sub>CC</sub> -100 and I <sub>EE</sub> -100 tests and remove the temperature reference in the conditions block for these tests.			
<b>11. THIS SECTION FOR GOVERNMENT USE ONLY</b>			
a. CHECK ONE <input checked="" type="checkbox"/> EXISTING DOCUMENT SUPPLEMENTED BY THIS NOR MAY BE USED IN MANUFACTURE. <input type="checkbox"/> REVISED DOCUMENT MUST BE RECEIVED BEFORE MANUFACTURER MAY INCORPORATE THIS CHANGE. <input type="checkbox"/> CUSTODIAN OF MASTER DOCUMENT SHALL MAKE ABOVE REVISION AND FURNISH REVISED DOCUMENT TO:			
b. ACTIVITY AUTHORIZED TO APPROVE CHANGE FOR GOVERNMENT DESC-ECT		<b>SIGNATURE AND TITLE</b> Greg Lude Branch Chief	<b>DATE (YYMMDD)</b> 91-11-06
<b>12. ACTIVITY ACCOMPLISHING REVISION</b> DESC-ECT		<b>REVISION COMPLETED (Signature)</b> Shelly M. Jenkins	<b>DATE (YYMMDD)</b> 91-11-06

REVISIONS

LTR	DESCRIPTION	DATE (YR-MO-DA)	APPROVED
A	Add device types 05 and 06. Correct coupling diagram, figure 4. Add common mode input voltage and test circuit. Table I, change ISIH. Editorial changes throughout.	91-05-17	W. Heckman

REV																				
SHEET																				
REV	A	A																		
SHEET	15	16																		
REV STATUS OF SHEETS			REV	A	A	A	A	A	A	A			A	A	A	A	A			
			SHEET	1	2	3	4	5	6	7	8	9	10	11	12	13	14			

<p>PMIC N/A</p> <p align="center"><b>STANDARDIZED MILITARY DRAWING</b></p> <p>THIS DRAWING IS AVAILABLE FOR USE BY ALL DEPARTMENTS AND AGENCIES OF THE DEPARTMENT OF DEFENSE</p> <p>AMSC N/A</p>	PREPARED BY Donald R. Osborne			DEFENSE ELECTRONICS SUPPLY CENTER DAYTON, OHIO 45444																
	CHECKED BY RAY MONNIN			MICROCIRCUIT, DIGITAL, LOW POWER, SINGLE CHANNEL, DRIVER-RECEIVER, HYBRID																
	APPROVED BY MICHAEL A. FRYE																			
	DRAWING APPROVAL DATE 20 JUNE 1989																			
	REVISION LEVEL  A			SIZE <b>A</b>	CAGE CODE <b>67268</b>	<b>5962-89592</b>														
			SHEET 1 OF 16																	

1. SCOPE

1.1 Scope. This drawing describes device requirements for class H hybrid microcircuits to be processed in accordance with MIL-H-38534.

1.2 Part or Identifying Number (PIN). The complete PIN shall be as shown in the following example:



1.2.1 Device type(s). The device type(s) shall identify the circuit function as follows:

<u>Device type</u>	<u>Generic number</u>	<u>Circuit function</u>
01 and 03	ARX3407	Single channel, driver-receiver (MIL-STD-1553 A and B) low power, receiver standby high
02 and 04	ARX3404	Single channel, driver-receiver (universal transceiver) low power, receiver standby high
05	ARX3467	Single channel, driver-receiver (MIL-STD-1553 A and B) low power, receiver standby low
06	ARX3464	Single channel, driver-receiver (universal transceiver) low power, receiver standby low

1.2.2 Case outline(s). The case outline(s) shall be as designated in appendix C of MIL-M-38510, and as follows:

<u>Outline letter</u>	<u>Case outline</u>
X	See figure 1 (24-lead, 1.27" x 1.27" x .175"), hybrid package
Y	See figure 1 (24-lead, 1.27" x 1.27" x .200"), flat package

1.3 Absolute maximum ratings.

Supply voltage:	
V <sub>CC</sub> .....	-0.3 V dc to +18 V dc
V <sub>EE</sub> .....	+0.3 V dc to -18 V dc
+5 V supply .....	-0.3 V dc to +7 V dc
Logic input voltage range .....	-0.3 V to +5.5 V
Receiver differential input voltage .....	40 Vp-p
Receiver common mode input voltage range .....	-10 V to +10 V
Driver peak output current .....	±300 mA
Storage temperature range .....	-65° C to +150° C
Lead temperature (soldering, 10 seconds) .....	+300° C
Junction temperature (T <sub>J</sub> ) .....	+160° C
Power dissipation (P <sub>D</sub> ) total hybrid:	
100 percent duty cycle (T <sub>C</sub> = +25° C):	
Device types 01, 03, and 05 .....	3.0 W
Device types 02, 04, and 06 .....	3.24 W
Standby mode, all devices .....	1.06 W

<b>STANDARDIZED MILITARY DRAWING</b> DEFENSE ELECTRONICS SUPPLY CENTER DAYTON, OHIO 45444	SIZE <b>A</b>		5962-89592
		REVISION LEVEL A	SHEET 2

Power dissipation ( $P_D$ ) hottest die:  
 100 percent duty cycle:  
 Device types 01, 03, and 05 ----- 484 mW 1/ 2/  
 Device types 02, 04, and 06 ----- 545 mW 2/ 3/  
 Standby mode, all devices ----- Derates to zero

Thermal resistance:  
 Junction-to-case ( $\theta_{JC}$ ) hottest die:  
 Device types 01, 02, 05, and 06 ----- 88° C/W  
 Device types 03 and 04 ----- 58° C/W  
 Case-to-ambient, all devices ----- 21° C/W

Maximum junction-to-case temperature rise for the  
 hottest die at 100 percent duty cycle:  
 Device types 01 and 05 ----- 42.6° C  
 Device types 02 and 06 ----- 47.9° C  
 Device type 03 ----- +28° C  
 Device type 04 ----- 31.6° C

1.4 Recommended operating conditions.

Supply voltage range:  
 $V_{CC}$  ----- +11.4 V dc to +15.75 V dc  
 $V_{EE}$  ----- -11.4 V dc to -15.75 V dc  
 5 V supply ----- +4.5 V dc to +5.5 V dc  
 Logic input voltage range ----- 0 V to +5.0 V  
 Receiver differential voltage ----- 40 Vp-p  
 Receiver common mode voltage range ----- -10.0 V to +10.0 V

Driver peak output current:  
 Device types 01, 02, 05, and 06 ----- ±180 mA  
 Device types 03 and 04 ----- ±120 mA  
 Maximum serial data rate ----- 1.0 MHz  
 Case operating temperature range ( $T_C$ ) ----- -55° C to +125° C

- 1/ Duty cycle at 1.0 MHz for device types 01 and 05. Derate to 82 percent maximum at  $T_C = +125° C$  for a maximum junction temperature of +160° C in the hottest die.  
2/ Duty cycle for device types 03 and 04 needs no derating over the full operating temperature range.  
3/ Duty cycle at 1.0 MHz for device types 02 and 06. Derate to 73 percent maximum at  $T_C = +125° C$  for a maximum junction temperature of +160° C in the hottest die.

<b>STANDARDIZED          MILITARY DRAWING</b> DEFENSE ELECTRONICS SUPPLY CENTER DAYTON, OHIO 45444	SIZE <b>A</b>		<b>5962-89592</b>
		REVISION LEVEL A	SHEET <b>3</b>

2. APPLICABLE DOCUMENTS

2.1 Government specifications and standard. Unless otherwise specified, the following specifications and standard of the issue listed in that issue of the Department of Defense Index of Specifications and Standards specified in the solicitation, form a part of this drawing to the extent specified herein.

SPECIFICATIONS

MILITARY

- MIL-M-38510 - Microcircuits, General Specification for.
- MIL-H-38534 - Hybrid Microcircuits, General Specification for.

STANDARD

MILITARY

- MIL-STD-883 - Test Methods and Procedures for Microelectronics.

(Copies of the specifications and standard required by manufacturers in connection with specific acquisition functions should be obtained from the contracting activity or as directed by the contracting activity.)

2.2 Order of precedence. In the event of a conflict between the text of this drawing and the references cited herein, the text of this drawing shall take precedence.

3. REQUIREMENTS

3.1 Item requirements. The individual item requirements shall be in accordance with MIL-H-38534 and as specified herein.

3.2 Design, construction, and physical dimensions. The design, construction, and physical dimensions shall be as specified in MIL-H-38534 and herein.

3.2.1 Case outline(s). The case outline(s) shall be in accordance with 1.2.2 herein.

3.2.2 Terminal connections. The terminal connections shall be as specified on figure 2.

3.3 Electrical performance characteristics. Unless otherwise specified herein, the electrical performance characteristics are as specified in table I and shall apply over the full specified operating temperature range.

3.4 Electrical test requirements. The electrical test requirements shall be the subgroups specified in table II. The electrical tests for each subgroup are described in table I.

3.5 Marking. Marking shall be in accordance with MIL-H-38534. The part shall be marked with the PIN listed in 1.2 herein. In addition, the manufacturer's PIN may also be marked as listed in QML-38534 (see 6.6 herein).

3.6 Manufacturer eligibility. In addition to the general requirements of MIL-H-38534, the manufacturer of the part described herein shall submit for DESC-ECC review and approval electrical test data (variables format) on 22 devices from the initial quality conformance inspection group A lot sample, produced on the certified line, for each device type listed herein. The data should also include a summary of all parameters manually tested, and for those which, if any, are guaranteed.

<b>STANDARDIZED MILITARY DRAWING</b> DEFENSE ELECTRONICS SUPPLY CENTER DAYTON, OHIO 45444	SIZE <b>A</b>		<b>5962-89592</b>
		REVISION LEVEL A	SHEET <b>4</b>

TABLE I. Electrical performance characteristics.

Test		Symbol	Conditions 1/ -55° C ≤ T <sub>C</sub> ≤ +125° C unless otherwise specified	Group A subgroups	Limits		Unit
					Min	Max	
Receiver	Output low voltage	V <sub>OL</sub>	I <sub>OL</sub> = 10 mA	1,2,3		0.5	V
	Output high voltage	V <sub>OH</sub>	I <sub>OH</sub> = -0.4 mA	1,2,3	2.5		V
	Differential input voltage level	V <sub>I</sub>		4,5,6		40	Vp-p
	Common mode input voltage range	V <sub>ICR</sub>	1 MHz sine wave See figure 3	4,5,6	10		Vp-p
	Differential input impedance	Z <sub>IN</sub>	1 MHz sine wave	4,5,6	10		kΩ
	Input capacitance	C <sub>IN</sub>	1 MHz sine wave 2/	4		5	pF
	Threshold voltage	V <sub>TH</sub>	3/ 4/	4,5,6	0.6	1.05	Vp-p
	Receiver delay	t <sub>DR</sub>	Input zero crossing 2/ to DATA or DATA, see figure 4	9,10,11		450	ns
Receiver strobe	Input low voltage	V <sub>SIL</sub>		1,2,3		0.7	V
	Input high voltage	V <sub>SIH</sub>		1,2,3	2.0		V
	Input low current	I <sub>SIL</sub>	V <sub>SIL</sub> = 0.4 V	1,2,3	-0.4		mA
	Input high current	I <sub>SIH</sub>	V <sub>SIH</sub> = 2.7 V	1,2,3		40	μA
	Strobe delay	t <sub>DS</sub>	Turn-on or turn-off, 2/ see figure 4	9,10,11		200	ns
Transmitter	Input low voltage	V <sub>IL</sub>		1,2,3		0.7	V
	Input high voltage	V <sub>IH</sub>		1,2,3	2.0		V
	Input low current	I <sub>IL</sub>	V <sub>IL</sub> = 0.4 V	1,2,3	-0.4		mA
	Input high current	I <sub>IH</sub>	V <sub>IH</sub> = 2.7 V	1,2,3		40	μA

See footnotes at end of table.

<b>STANDARDIZED MILITARY DRAWING</b> DEFENSE ELECTRONICS SUPPLY CENTER DAYTON, OHIO 45444	SIZE <b>A</b>		<b>5962-89592</b>
		REVISION LEVEL A	SHEET <b>5</b>

TABLE I. Electrical performance characteristics - Continued.

Test		Symbol	Conditions 1/ -55° C ≤ T <sub>C</sub> ≤ +125° C unless otherwise specified	Group A subgroups	Limits		Unit	
					Min	Max		
Transmitter (continued)	Differential output voltage	V <sub>O</sub>	4/ 35Ω load	1,2,3	6.5	8.5	Vp-p	
			5/ 140Ω load		26	34		
	Differential output noise	V <sub>ON</sub>	4/ Inhibited 35Ω load	4,5,6		10	mVp-p	
			5/ 140Ω load			40		
	Differential output impedance	Z <sub>OUT</sub>	1 MHz sine wave (transmitter off)	4,5,6	10		kΩ	
	Output capacitance	C <sub>OUT</sub>	1 MHz sine wave 2/	4		5	pF	
	Differential output offset voltage	V <sub>OS</sub>	35Ω load	4,5,6	-90	+90	mV pk	
			5/ 6/ 140Ω load		-360	+360		
	Receiver filter response	FILTER	f = 2 MHz		4,5,6	-4.0		dB
			f = 4 MHz			-13		
Rise time	t <sub>R</sub>	35Ω load, see figure 4	device types 01, 03, and 05	9,10,11	100	300	ns	
			device types 02, 04, and 06		220	300		
Fall time	t <sub>F</sub>	35Ω load, see figure 4	device types 01, 03, and 05		100	300		
			device types 02, 04, and 06		220	300		
Transmitter delay	t <sub>DT</sub>	Transmitter-in to 2/ transmitter-out, see figure 4				550		
Transmitter inhibit	Input low voltage	V <sub>IIL</sub>		1,2,3		0.7	V	
	Input high voltage	V <sub>IHH</sub>		1,2,3	2.0		V	
	Input low current	I <sub>IIL</sub>	V <sub>SIL</sub> = 0.4 V	1,2,3	-0.4		mA	
	Input high current	I <sub>IHH</sub>	V <sub>SIH</sub> = 2.7 V	1,2,3		40	μA	
	Transmitter inhibit delay (high)	t <sub>DI-H</sub>	0-1 inhibited output, 2/ see figure 4		9,10,11		450	ns

See footnotes at end of table.

**STANDARDIZED  
MILITARY DRAWING**  
DEFENSE ELECTRONICS SUPPLY CENTER  
DAYTON, OHIO 45444

SIZE  
**A**

**5962-89592**

REVISION LEVEL  
A

SHEET  
**6**

TABLE I. Electrical performance characteristics - Continued.

Test		Symbol	Conditions 1/ -55° C ≤ T <sub>C</sub> ≤ +125° C unless otherwise specified		Group A subgroups	Limits		Unit
						Min	Max	
Transmitter inhibit	Transmitter inhibit delay (low)	t <sub>DI-L</sub>	1-0 active output, 2/ see figure 4		9,10,11		450	ns
Power supply	+Supply (V <sub>CC</sub> ) -Supply (V <sub>EE</sub> ) +5 V supply	I <sub>CC-SB</sub> I <sub>EE-SB</sub> I <sub>CC1-SB</sub>	Standby mode		1,2,3		20 35 35	mA
	+Supply (V <sub>CC</sub> ) -Supply (V <sub>EE</sub> )	I <sub>CC-50</sub> I <sub>EE-50</sub>	50% duty cycle		4,5,6		75 92.5	
	+Supply (V <sub>CC</sub> )    -Supply (V <sub>EE</sub> )	I <sub>CC-100</sub>	100% duty cycle -55° C ≤ T <sub>C</sub> ≤ +25° C	device types 01, 02, 05, and 06	4,6		130	
						device types 03 and 04	4,5,6	
		I <sub>EE-100</sub>	-55° C ≤ T <sub>C</sub> ≤ +25° C	device types 01, 02, 05, and 06	4,6		150	
					device types 03 and 04	4,5,6		150

1/ (+14.9 ≤ V<sub>CC</sub> ≤ +15.1 V dc), (-14.9 ≤ V<sub>EE</sub> ≤ -15.1 V dc), (+4.9 ≤ +5 V supply ≤ +5.1 V dc).

2/ Parameter shall be tested as part of initial characterization and after design and process changes. Parameters shall be guaranteed to limits specified in table I for all lots not specifically tested.

3/ Threshold determined by absence of output on receiver (i.e., full rejection).

4/ Measured at point AA' of figure 5.

5/ Measured at point BB' of figure 5.

6/ Offset is measured 2.5 μs after the mid-bit zero crossing of the last parity bit of a 660 μs transmission cycle of contiguous words (no dead time in between words).

<b>STANDARDIZED MILITARY DRAWING</b> DEFENSE ELECTRONICS SUPPLY CENTER DAYTON, OHIO 45444	SIZE <b>A</b>		<b>5962-89592</b>
		REVISION LEVEL A	SHEET <b>7</b>

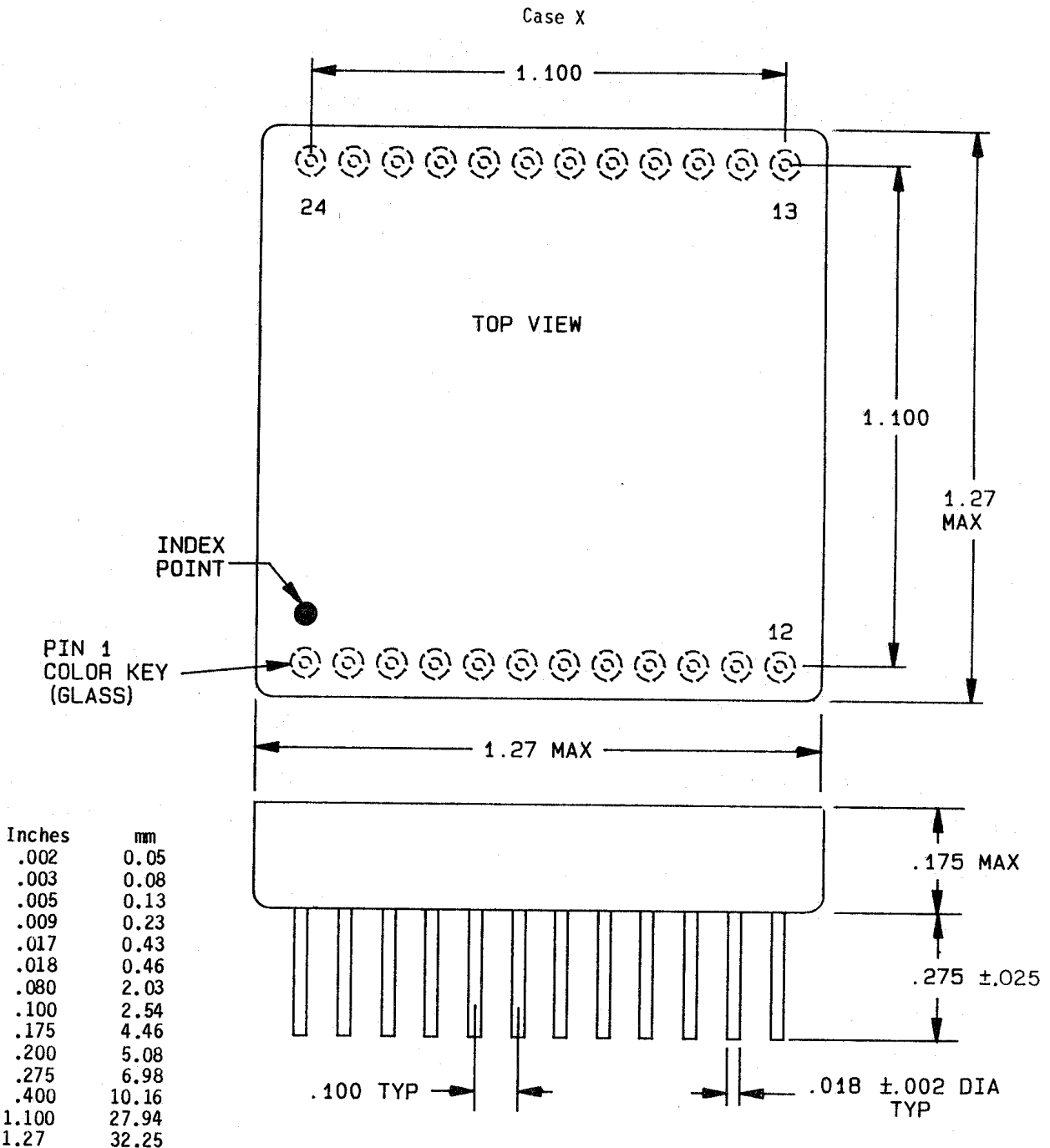
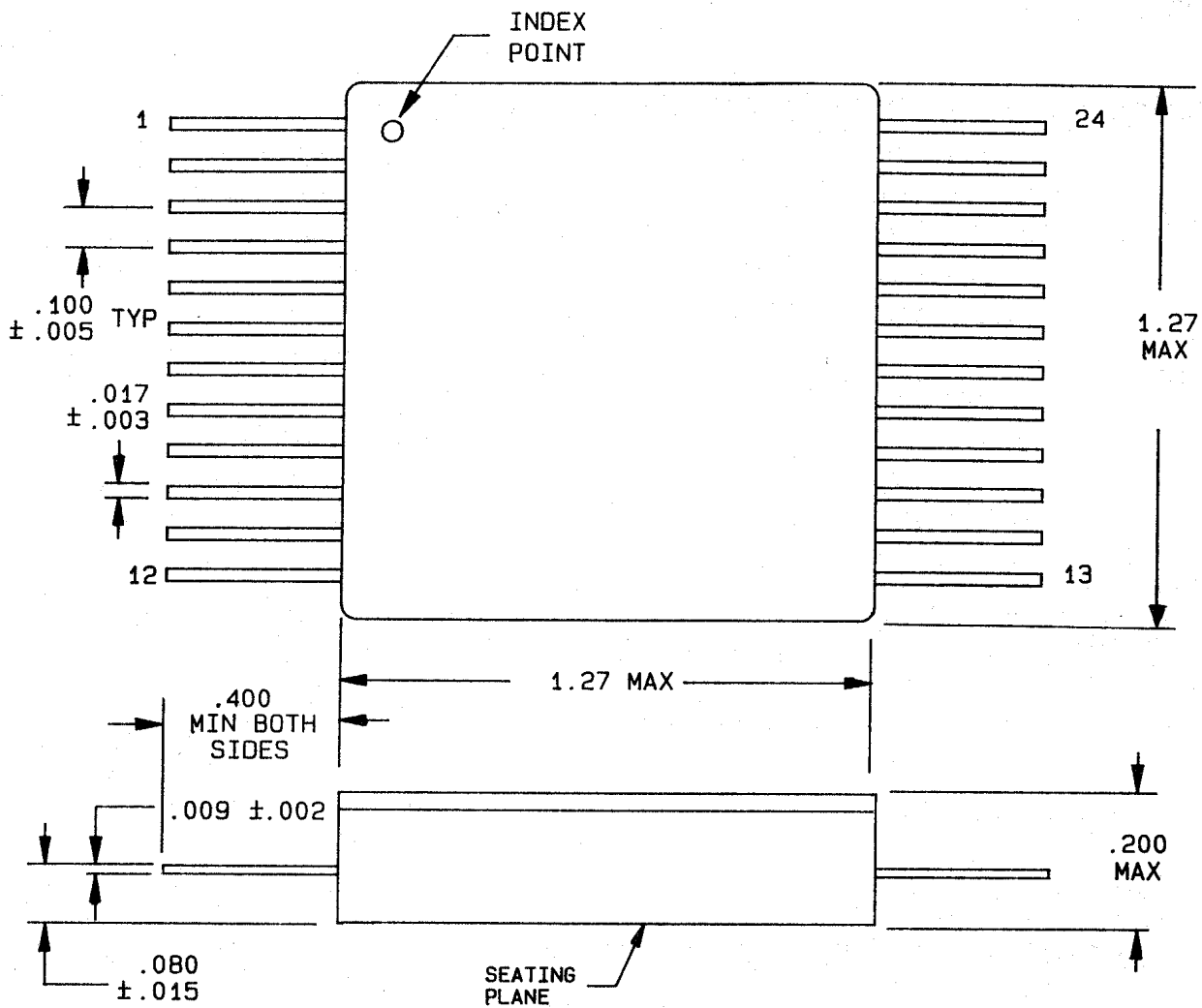

FIGURE 1. Case outlines.

<p align="center"><b>STANDARDIZED MILITARY DRAWING</b></p> <p>DEFENSE ELECTRONICS SUPPLY CENTER DAYTON, OHIO 45444</p>	<p align="center">SIZE <b>A</b></p>		<p align="center"><b>5962-89592</b></p>
		<p align="center">REVISION LEVEL A</p>	<p align="center">SHEET <b>8</b></p>



NOTES (for case X and case Y):

1. Dimensions are in inches.
2. Metric equivalents are given for general information only.
3. Unless otherwise specified, tolerance for three place decimals shall be .005 (0.13 mm).

FIGURE 1. Case outlines - Continued.

<b>STANDARDIZED MILITARY DRAWING</b> DEFENSE ELECTRONICS SUPPLY CENTER DAYTON, OHIO 45444	SIZE <b>A</b>		<b>5962-89592</b>
		REVISION LEVEL A	SHEET <b>9</b>

Device types 01, 02, 03, 04, 05, and 06.

Pin	Function	Pin	Function
1	TX DATA OUT	13	+15 V
2	TX $\overline{\text{DATA}}$ OUT	14	NC
3	TX GND	15	RX DATA IN
4	+15 V	16	RX $\overline{\text{DATA}}$ IN
5	NC	17	GND
6	NC	18	CASE GND
7	RX DATA OUT	19	-15 V
8	RX STROBE	20	+5 V
9	RX GND	21	TX INHIBIT
10	RX $\overline{\text{DATA}}$ OUT	22	TX DATA IN
11	NC	23	TX $\overline{\text{DATA}}$ IN
12	NC	24	-15 V

FIGURE 2. Terminal connections.

<b>STANDARDIZED MILITARY DRAWING</b> DEFENSE ELECTRONICS SUPPLY CENTER DAYTON, OHIO 45444	SIZE <b>A</b>		<b>5962-89592</b>
		REVISION LEVEL A	SHEET <b>10</b>

## COMMON - MODE TEST

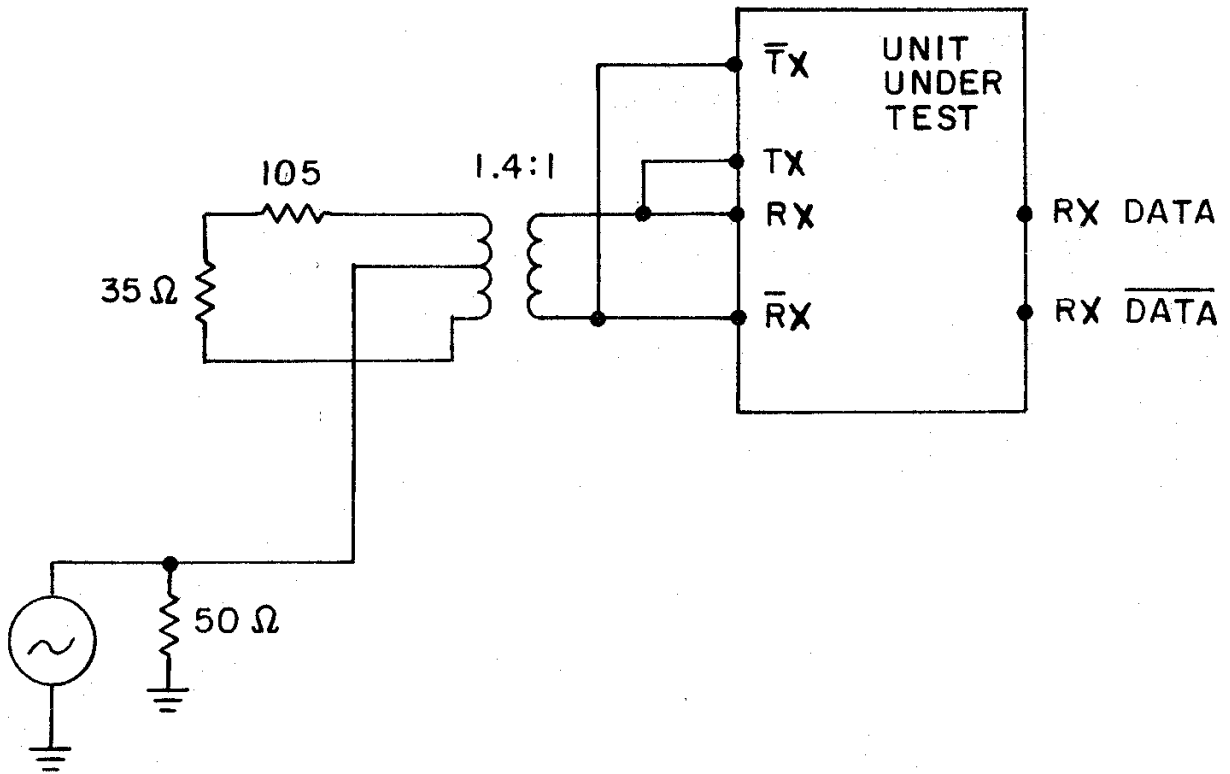

FIGURE 3. Test circuit.

**STANDARDIZED  
MILITARY DRAWING**  
DEFENSE ELECTRONICS SUPPLY CENTER  
DAYTON, OHIO 45444

SIZE  
**A**

5962-89592

REVISION LEVEL  
A

SHEET  
11

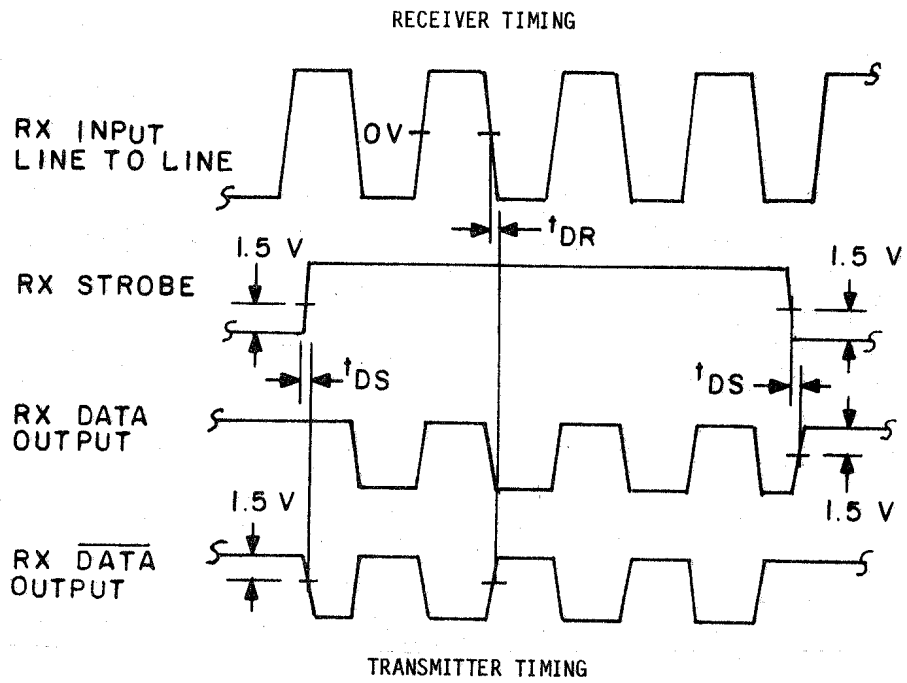

Device types 01, 02, 03, and 04.

FIGURE 4. Timing waveforms.

**STANDARDIZED  
MILITARY DRAWING**  
DEFENSE ELECTRONICS SUPPLY CENTER  
DAYTON, OHIO 45444

SIZE  
**A**

5962-89592

REVISION LEVEL  
A

SHEET  
12

RECEIVER TIMING

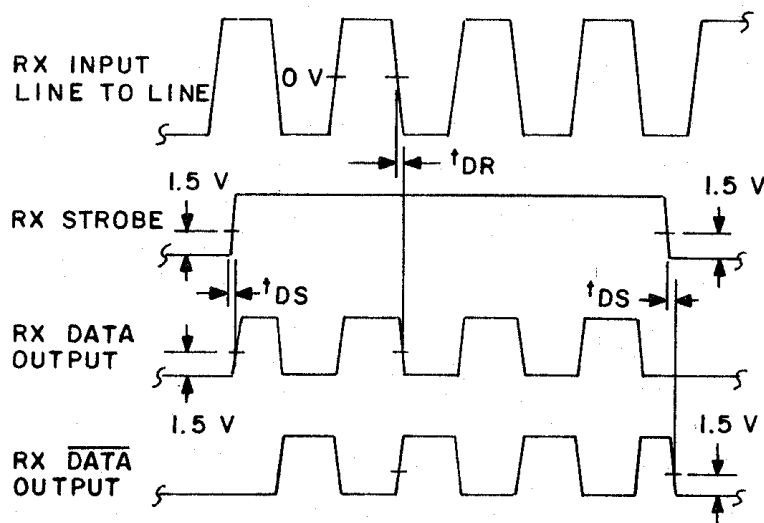

TRANSMITTER TIMING

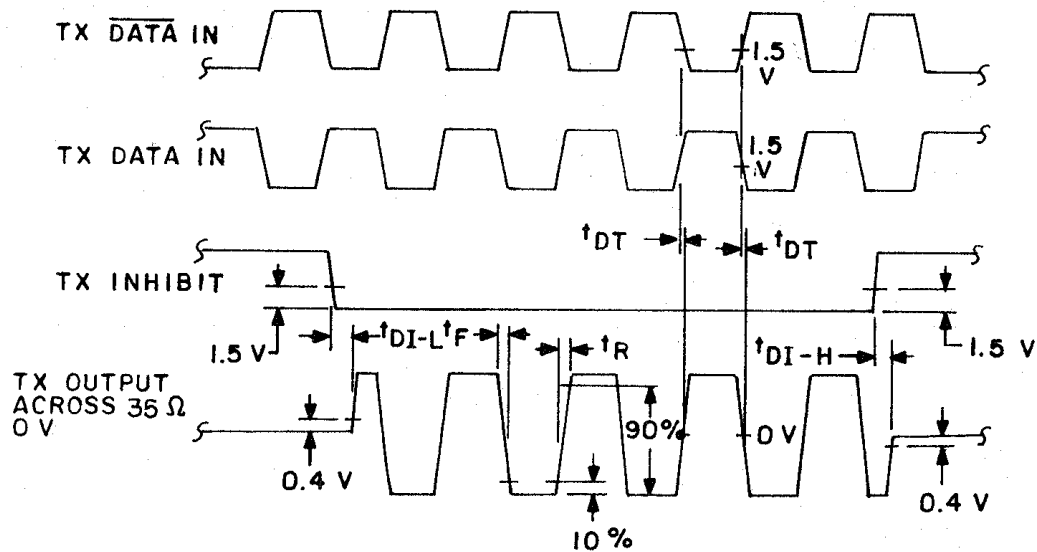

Device types 05 and 06.

FIGURE 4. Timing waveforms - Continued.

STANDARDIZED  
MILITARY DRAWING  
DEFENSE ELECTRONICS SUPPLY CENTER  
DAYTON, OHIO 45444

SIZE  
A

5962-89592

REVISION LEVEL  
A

SHEET  
13

$Z_0$  (70Ω NOM)

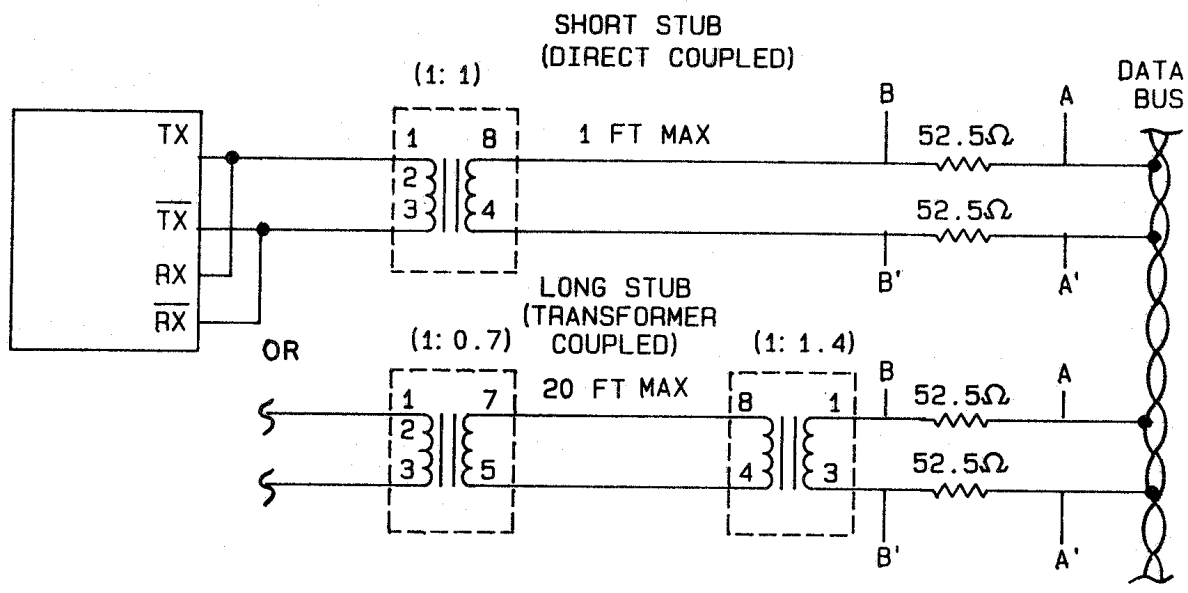

FIGURE 5. Coupling diagram.

<b>STANDARDIZED MILITARY DRAWING</b> DEFENSE ELECTRONICS SUPPLY CENTER DAYTON, OHIO 45444	SIZE <b>A</b>		<b>5962-89592</b>
		REVISION LEVEL A	SHEET <b>14</b>

3.7 Certificate of compliance. A certificate of compliance shall be required from a manufacturer in order to be listed as an approved source of supply in QML-38534 (see 6.6 herein). The certificate of compliance submitted to DESC-ECC prior to listing as an approved source of supply shall affirm that the manufacturer's product meets the requirements of MIL-H-38534 and the requirements herein.

3.8 Certificate of conformance. A certificate of conformance as required in MIL-H-38534 shall be provided with each lot of microcircuits delivered to this drawing.

4. QUALITY ASSURANCE PROVISIONS

4.1 Sampling and inspection. Sampling and inspection procedures shall be in accordance with MIL-H-38534.

4.2 Screening. Screening shall be in accordance with MIL-H-38534. The following additional criteria shall apply:

a. Burn-in test, method 1015 of MIL-STD-883.

(1) Test condition A, B, C, or D using the circuit submitted with the certificate of compliance (see 3.7 herein).

(2)  $T_A$  as specified in accordance with table I of method 1015 of MIL-STD-883.

b. Interim and final electrical test parameters shall be as specified in table II herein, except interim electrical parameter tests prior to burn-in are optional at the discretion of the manufacturer.

4.3 Quality conformance inspection. Quality conformance inspection shall be in accordance with MIL-H-38534 and as specified herein.

4.3.1 Group A inspection. Group A inspection shall be in accordance with MIL-H-38534 and as follows:

a. Tests shall be as specified in table II herein.

b. Subgroups 7 and 8 shall be omitted.

4.3.2 Group B inspection. Group B inspection shall be in accordance with MIL-H-38534.

4.3.3 Group C inspection. Group C inspection shall be in accordance with MIL-H-38534 and as follows:

a. End-point electrical parameters shall be as specified in table II herein.

b. Steady-state life test conditions, method 1005 of MIL-STD-883.

(1) Test condition A, B, C, or D using the circuit submitted with the certificate of compliance (see 3.7 herein).

(2)  $T_A$  as specified in accordance with table I of method 1005 of MIL-STD-883.

(3) Test duration: 1,000 hours, except as permitted by method 1005 of MIL-STD-883.

4.3.4 Group D inspection. Group D inspection shall be in accordance with MIL-H-38534.

<b>STANDARDIZED MILITARY DRAWING</b> DEFENSE ELECTRONICS SUPPLY CENTER DAYTON, OHIO 45444	SIZE <b>A</b>		<b>5962-89592</b>
		REVISION LEVEL A	SHEET <b>15</b>

TABLE II. Electrical test requirements.

MIL-STD-883 test requirements	Subgroups (per method 5008, group A test table)
Interim electrical parameters	1
Final electrical test parameters	1*,2,3,4,5,6,9, 10,11
Group A test requirements	1,2,3,4,5,6,9, 10,11
Group C end-point electrical parameters	1,2,3

\* PDA applies to subgroup 1.

5. PACKAGING

5.1 Packaging requirements. The requirements for packaging shall be in accordance with MIL-H-38534.

6. NOTES

6.1 Intended use. Microcircuits conforming to this drawing are intended for original equipment design applications and logistic support of existing equipment.

6.2 Replaceability. Microcircuits covered by this drawing will replace the same generic device covered by a contractor-prepared specification or drawing.

6.3 Configuration control of SMD's. All proposed changes to existing SMD's will be coordinated with the users of record for the individual documents. This coordination will be accomplished in accordance with MIL-STD-481 using DD Form 1693, Engineering Change Proposal (Short Form).

6.4 Record of users. Military and industrial users shall inform Defense Electronics Supply Center when a system application requires configuration control and the applicable SMD. DESC will maintain a record of users and this list will be used for coordination and distribution of changes to the drawings. Users of drawings covering microelectronics devices (FSC 5962) should contact DESC-ECC, telephone (513) 296-8527.

6.5 Comments. Comments on this drawing should be directed to DESC-ECC, Dayton, Ohio 45444, or telephone (513) 296-8525.

6.6 Approved sources of supply. Approved sources of supply are listed in QML-38534. Additional sources will be added to QML-38534 as they become available. The vendors listed in QML-38534 have agreed to this drawing and a certificate of compliance (see 3.7 herein) has been submitted to and accepted by DESC-ECC.

<b>STANDARDIZED MILITARY DRAWING</b> DEFENSE ELECTRONICS SUPPLY CENTER DAYTON, OHIO 45444	SIZE <b>A</b>		<b>5962-89592</b>
		REVISION LEVEL A	SHEET <b>16</b>

STANDARDIZED MILITARY DRAWING SOURCE APPROVAL BULLETIN

DATE: 91-05-17

Approved sources of supply for SMD 5962-89592 are listed below for immediate acquisition only and shall be added to QML-38534 during the next revision. QML-38534 will be revised to include the addition or deletion of sources. The vendors listed below have agreed to this drawing and a certificate of compliance has been submitted to and accepted by DESC-ECC. This bulletin is superseded by the next dated revision of QML-38534.

Standardized military drawing PIN	Vendor CAGE number	Vendor similar PIN <u>1/</u>
5962-8959201XX	88379	ARX3407
5962-8959201YX	88379	ARX3407FP
5962-8959202XX	88379	ARX3404
5962-8959202YX	88379	ARX3404FP
5962-8959203XX	88379	ARX3407-001
5962-8959203YX	88379	ARX3407-001FP
5962-8959204XX	88379	ARX3404-001
5962-8959204YX	88379	ARX3404-001FP
5962-8959205XX	88379	ARX3467
5962-8959205YX	88379	ARX3467FP
5962-8959206XX	88379	ARX3464
5962-8959206YX	88379	ARX3464FP

1/ Caution. Do not use this number for item acquisition. Items acquired to this number may not satisfy the performance requirements of this drawing.

Vendor CAGE number

Vendor name and address

88379

Aeroflex Laboratories, Incorporated  
35 South Service Road  
Plainview, NY 11803

The information contained herein is disseminated for convenience only and the Government assumes no liability whatsoever for any inaccuracies in this information bulletin.