

ENGINEERING DATA SHEET

SERIES THLAO

RAILWAY TIME DELAY RELAY
PROGRAMMABLE TIMER WITH
SOLID STATE OUTPUT

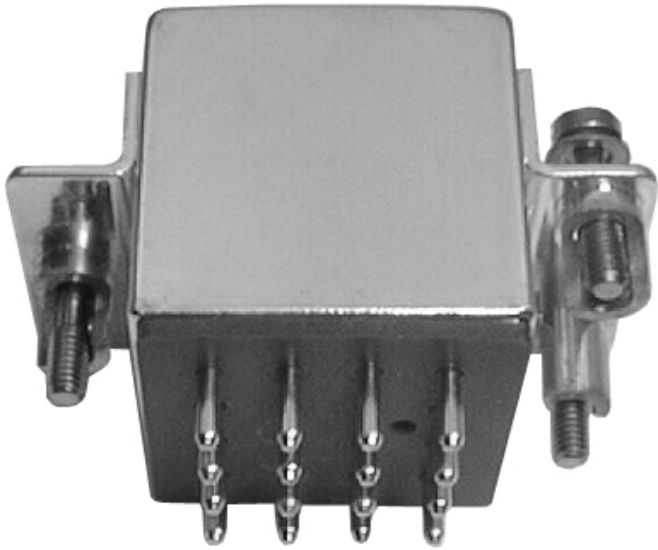

APPLICATION NOTES:
[007](#)

APPLICABLE SOCKET:
[SF402CE40E](#)
[SF402-1F](#)

Time delay on operate in a hermetically sealed package

Time delay programmable by wiring

Output characteristics **1 solid state output**

Supply **Direct current**

PRINCIPLE TECHNICAL CHARACTERISTICS

Contact rating **0.01 to 0.25 Amp at nominal voltage**

Weight **< 80 grams**

Dimensions of can without hardware **26mm x 25.7mm x 26mm max**

Tin plated, hermetically sealed metal can.

GENERAL CHARACTERISTICS

Operating temperature	-25°C to +70°C
Dielectric strength at sea level	
All terminals to ground	1500 Vrms / 50 Hz
Initial insulation resistance at 500 Vdc	>1000 M Ω
Sinusoidal vibration	10 G / 10 to 2000 Hz
Shock	30 G / 11 ± 1 ms
Timing accuracy over temperature range	± 10%
Protection against reverse polarity	yes



Featuring **LEACH**® power and control solutions
www.esterline.com

AMERICAS
6900 Orangethorpe Ave.
P.O. Box 5032
Buena Park, CA 90622

Tel: (01) 714-736-7599
Fax: (01) 714-670-1145

EUROPEASIA
2 Rue Units
Goethe 602-603
57430 6/F
Sarralbe Lakeside
France 1
No.8
Science
Tel: (33) Park
3 87 97 West
31 01 Avenue
Fax: Phase
(33) 3 Two,
87 97 96 Hong
86 Kong
Science
Park
Pak
Shek
Kok, Tai
Po, N.T.
Hong
Kong
Tel:
(852) 2
191 3830
Fax:
(852) 2
389
5803

Data sheets are for initial product selection and comparison. Contact Esterline Power Systems prior to choosing a component.

TIMING DIAGRAM

SERIES THLAO

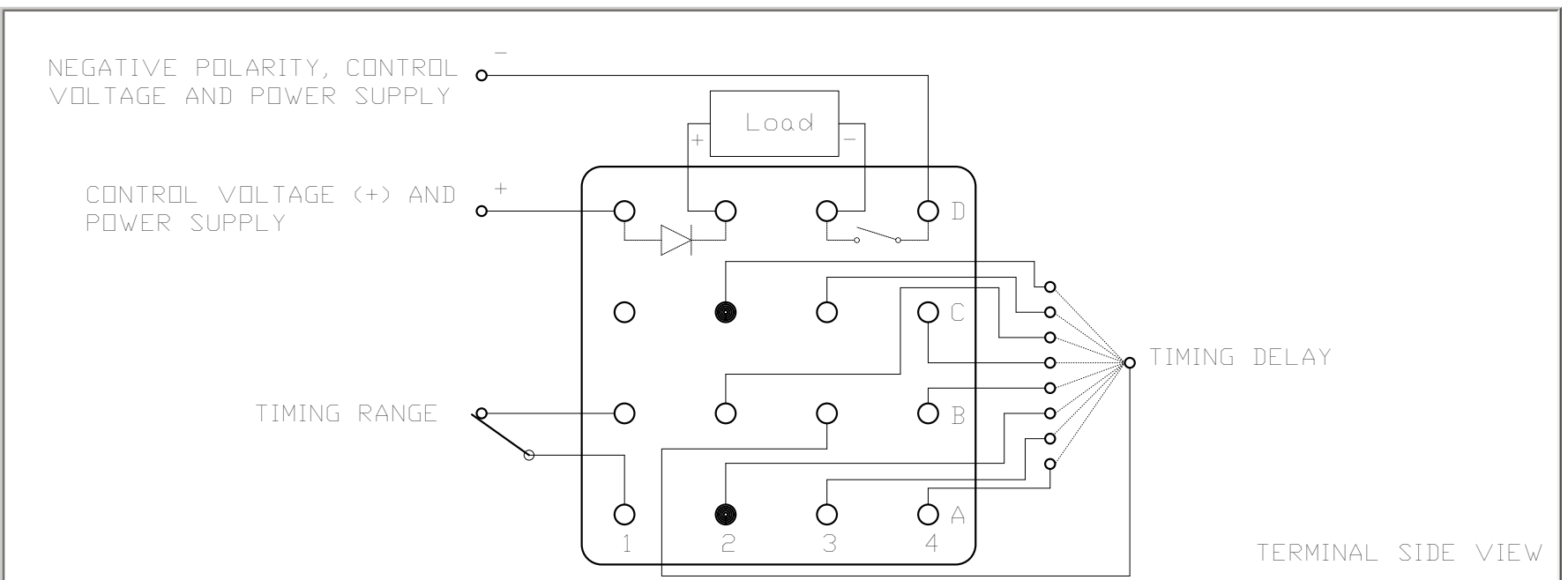
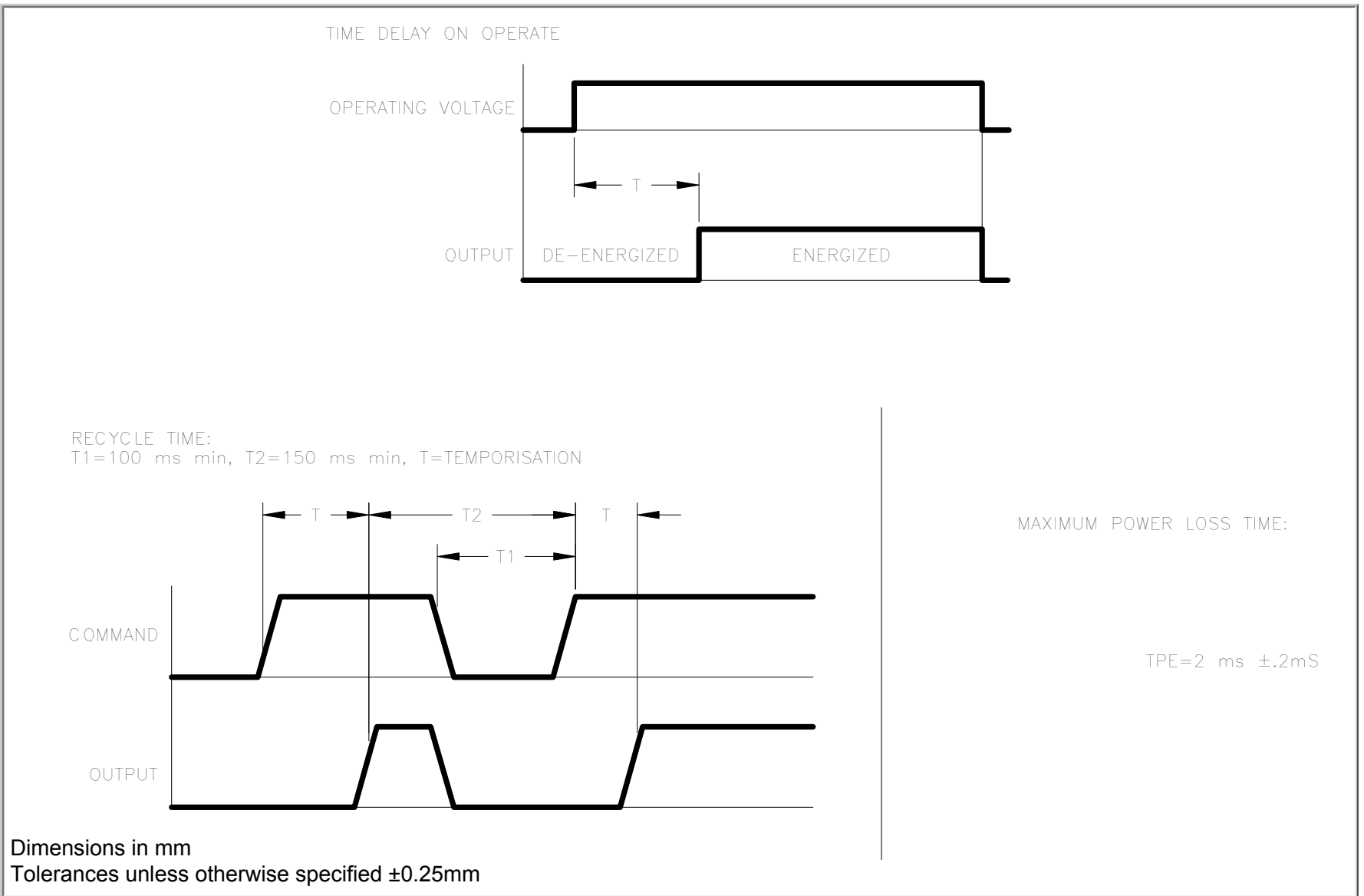

Dimensions in mm
Tolerances unless otherwise specified ±0.25mm

Nominal operating voltage (Un)	24 Vdc	48 Vdc	72 Vdc	110 Vdc
Minimum operating voltage	16.8 Vdc	40 Vdc	50 Vdc	77 Vdc
Maximum operating voltage	33 Vdc	60 Vdc	90 Vdc	137 Vdc
Maximum current draw at Un	20 mA	20 mA	20 mA	20 mA

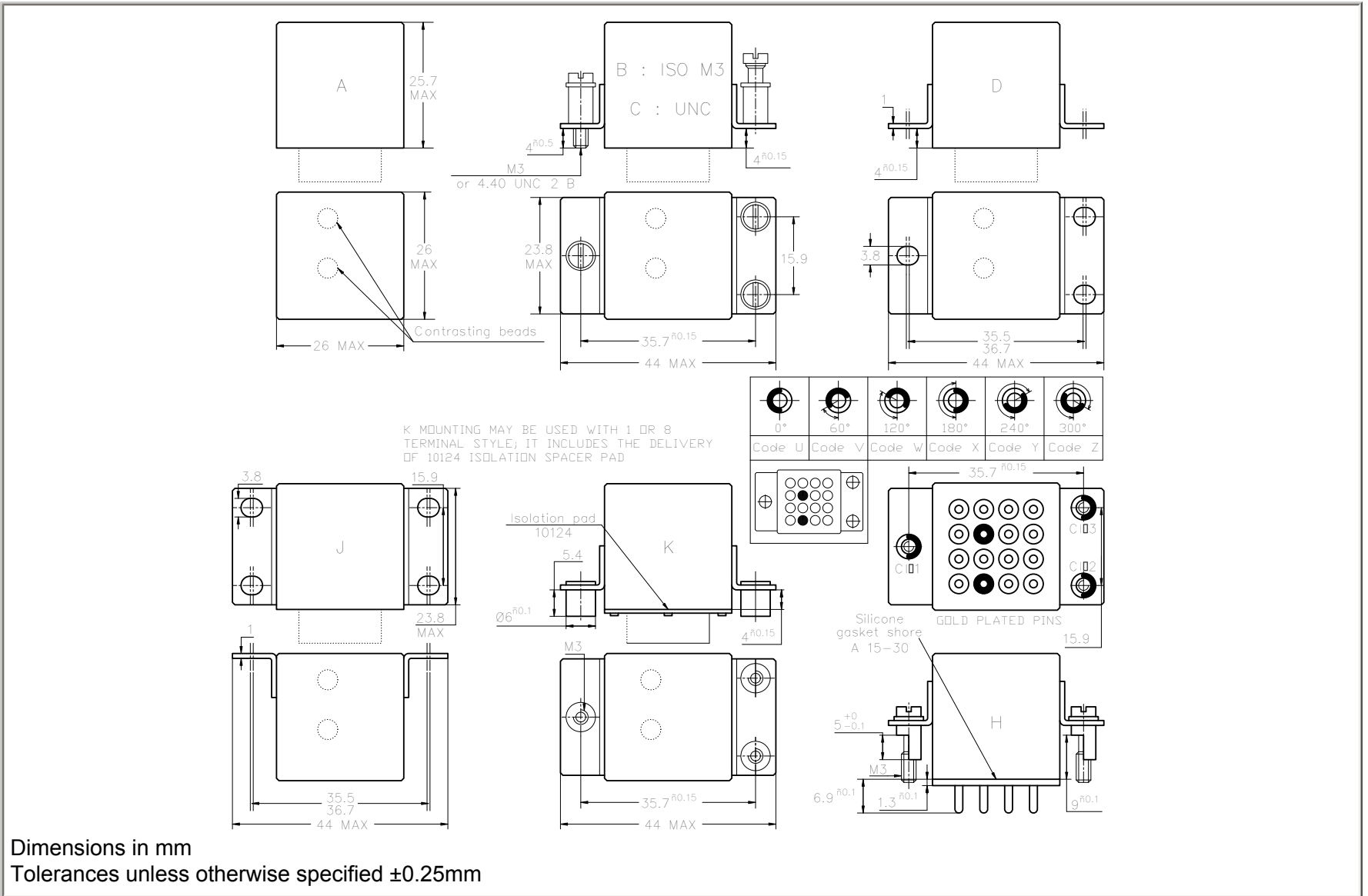

SCHEMATIC DIAGRAM

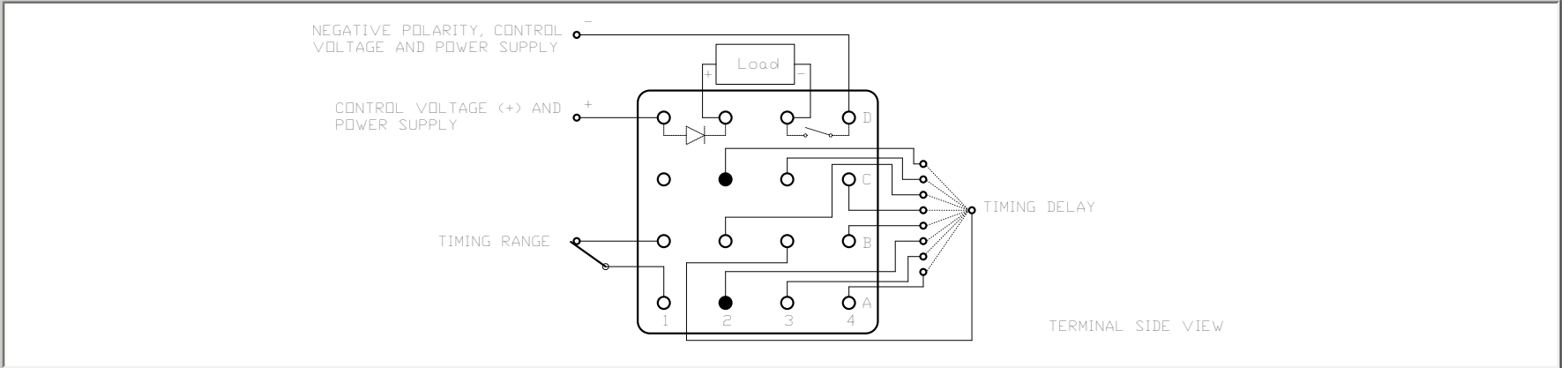

TERMINAL TYPES

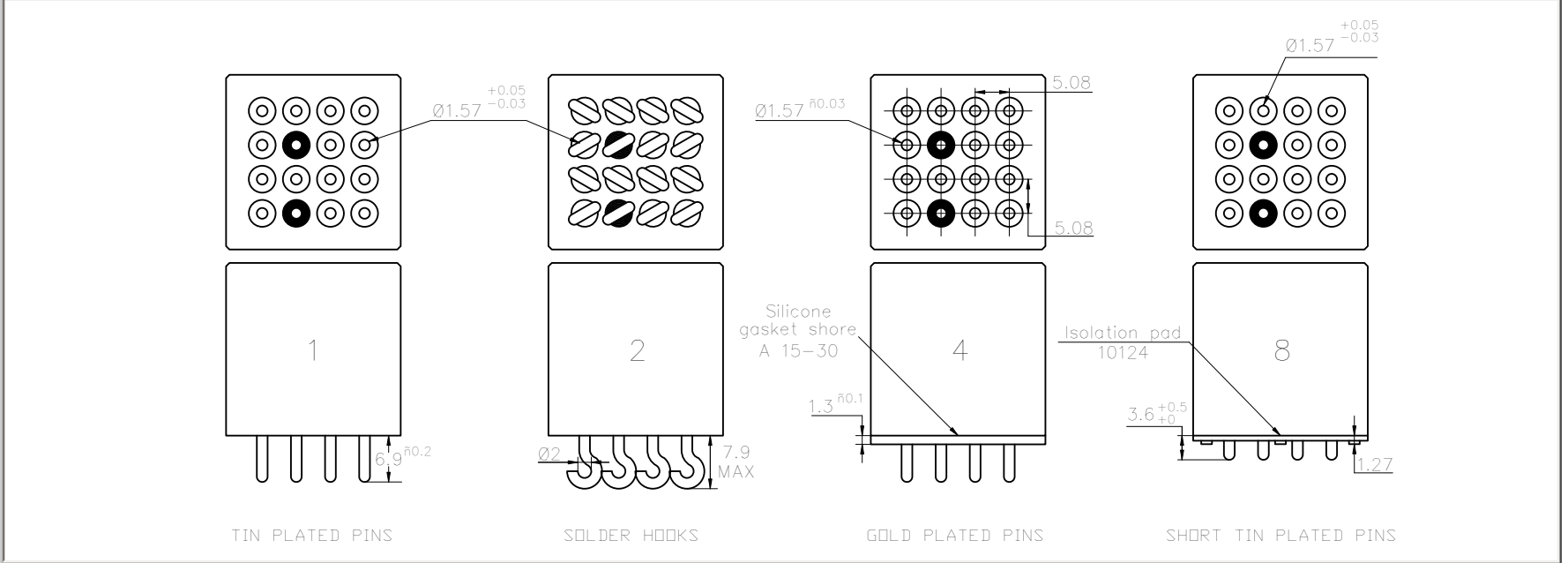

NUMBERING SYSTEM

SERIES THLAO

	THLAO	72	H	4	YWY
Basic series designation_____					
Operating voltage (24,48,72,110)_____					
1-Mounting Styles (A,B,C,D,J,K,H)_____					
2-Terminal Types(1,2,4,8)_____					
3-Coding keys for H mounting style_____					

NOTES

1. Relays with B, D mounting styles and terminal type 4 are compatible with socket SF402CE40E.
2. Relays with H mounting style are compatible with socket SF402-1F.
3. Isolation spacer pads for PCB mounting available on request.
4. For other mounting styles or terminal types or coding, please contact factory.

CODING CHART FOR H MOUNTING

Operating voltage	24 V	48 V	72 V	110 V
Coding	YUY	YVY	YWY	YXY

TIMING PROGRAMMATION

Timing range	Terminals to connect	Timing delay	Timing range	Terminals to connect	Timing delay
1 a1-b1 connected	b3-a2	0.25 s	2 a1-b1 non connected	b3-a2	0.25 mn
	b3-a3	0.5 s		b3-a3	0.5 mn
	b3-a4	1 s		b3-a4	1 mn
	b3-b4	2 s		b3-b4	2 mn
	b3-c4	4 s		b3-c4	4 mn
	b3-c3	8 s		b3-c3	8 mn
	b3-c2	16 s		b3-c2	16 mn
	b3-b2	32 s		b3-b2	32 mn
	Time delay options from 0.25 to 63.75 seconds			Time delay options from 0.25 to 63.75 seconds	

Intermediate time delay may be obtained by multiple wiring.
 Example: for 12 s = 8 s + 4 s, connect C3 and C4 to B3.

SUPPRESSOR DEVICES FOR RELAY COILS

The inductive nature of relay coils allows them to create magnetic forces which are converted to mechanical movements to operate contact systems. When voltage is applied to a coil, the resulting current generates a magnetic flux, creating mechanical work. Upon deenergizing the coil, the collapsing magnetic field induces a reverse voltage (also known as back EMF) which tends to maintain current flow in the coil. The induced voltage level mainly depends on the duration of the deenergization. The faster the switch-off, the higher the induced voltage.

All coil suppression networks are based on a reduction of speed of current decay. This reduction may also slow down the opening of contacts, adversely effecting contact life and reliability. Therefore, it is very important to have a clear understanding of these phenomena when designing a coil suppression circuitry.

Typical coil characteristics

On the graph below, the upper record shows the contacts state. (High level NO contacts closed, low level NC contacts closed, intermediate state contact transfer). The lower record shows the voltage across the coil when the current is switched off by another relay contact.

The surge voltage is limited to -300V by the arc generated across contact poles. Discharge duration is about 200 microseconds after which the current change does not generate sufficient voltage. The voltage decreases to the point where the contacts start to move, at this time, the voltage increases due to the energy contained in the NO contact springs. The voltage decreases again during transfer, and increases once more when the magnetic circuit is closed on permanent magnet.

- Operating times are as follows:
- Time to start the movement 1.5ms
- Total motion time 2.3ms
- Transfer time 1.4ms

Contact State

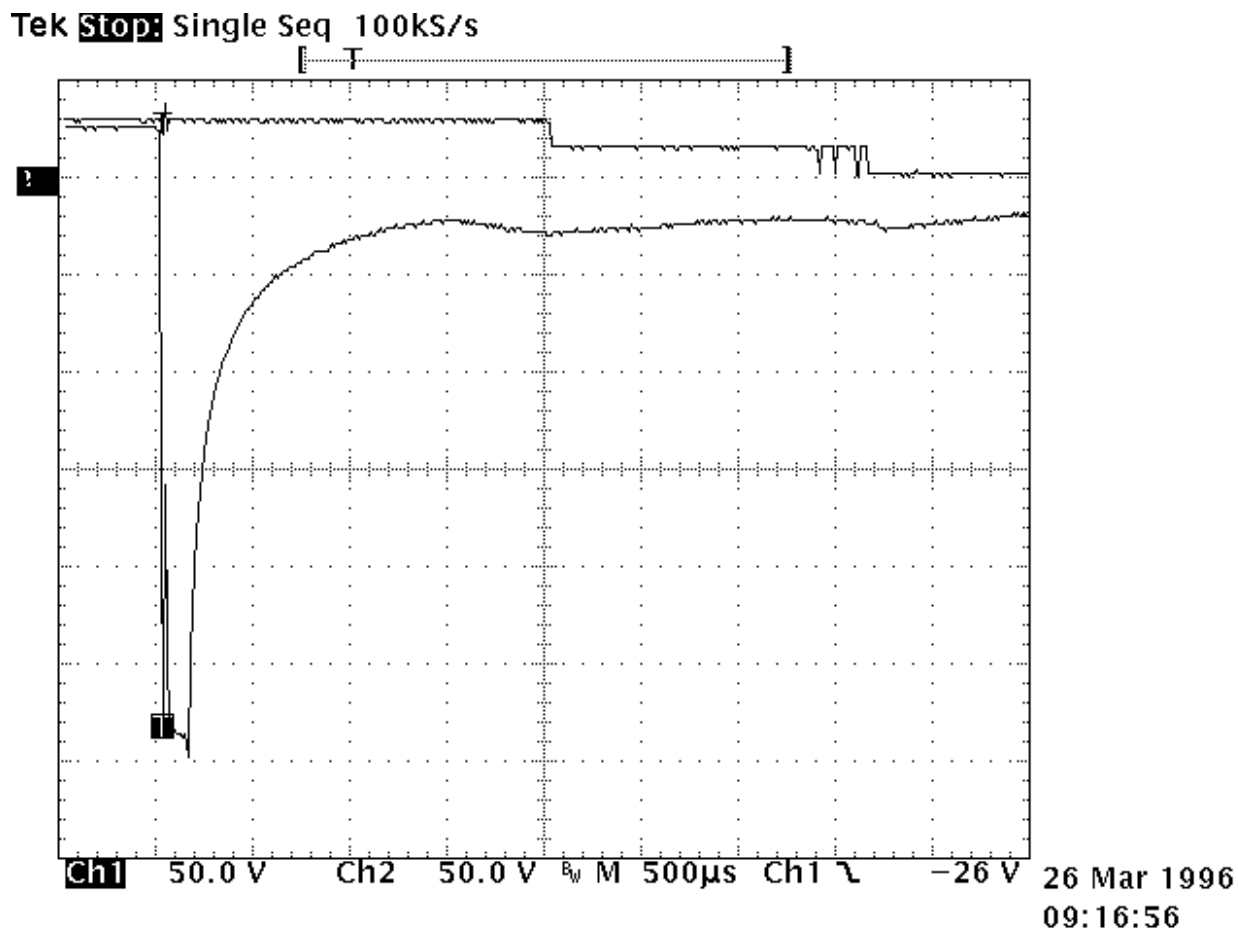

Types of suppressors:

Passive devices.

The resistor capacitor circuit

It eliminates the power dissipation problem, as well as fast voltage rises. With a proper match between coil and resistor, approximate capacitance value can be calculated from:

$C = 0.02 \times T/R$, where

T = operating time in milliseconds

R = coil resistance in kiloOhms

C = capacitance in microFarads

The series resistor must be between 0.5 and 1 times the coil resistance. Special consideration must be taken for the capacitor inrush current in the case of a low resistance coil.

The record shown opposite is performed on the same relay as above. The operation time becomes:

- time to start the movement 2.3ms

- transfer time 1.2ms

The major difficulty comes from the capacitor volume. In our example of a relay with a 290Ω coil and time delay of 8 ms, a capacitance value of $C=0.5 \mu\text{F}$ is found. This non polarized capacitor, with a voltage of 63V minimum, has a volume of about 1cm^3 . For 150V, this volume becomes 1.5cm^3 .

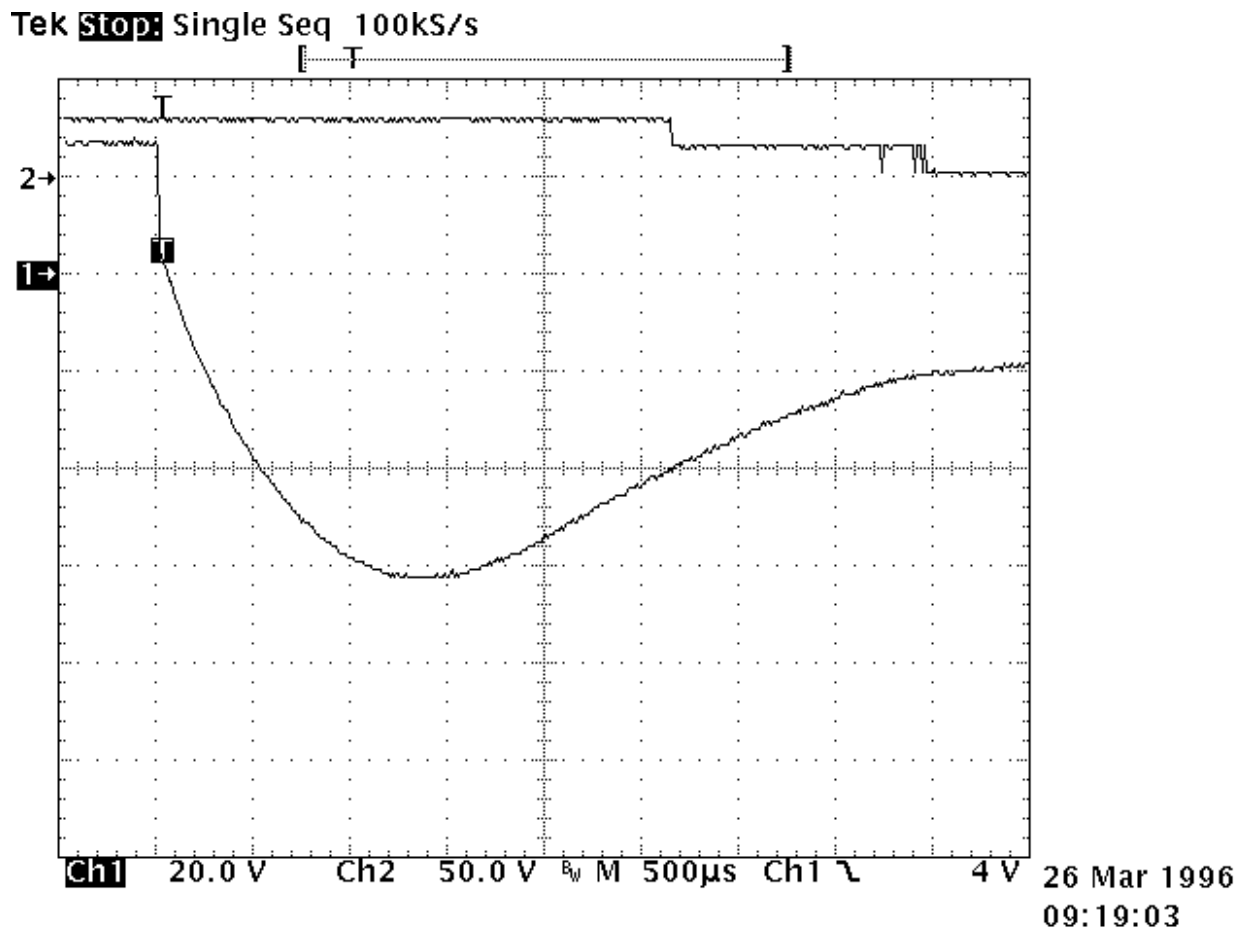

The bifilar coil

The principle is to wind on the magnetic circuit of the main coil a second coil shorted on itself. By a proper adaptation of the internal resistance of this second coil it is possible to find an acceptable equilibrium between surge voltage and reduction of the opening speed. To be efficient at fast voltage changes, the coupling of two coils must be perfect. This implies embedded windings. The volume occupied by the second coil reduces the efficiency of the main coil and results in higher coil power consumption. This method cannot be applied efficiently to products not specifically designed for this purpose.

The resistor (parallel with the coil)

For efficient action, the resistor must be of the same order of magnitude as the coil resistance. A resistor 1.5 times the coil resistance will limit the surge to 1.5 times the supply voltage. Release time and opening speed are moderately affected. The major problem is the extra power dissipated.

Semi-conductor devices

The diode

It is the most simple method to totally suppress the surge voltage. It has the major disadvantage of the higher reduction of contact opening speed. This is due to the total recycling, through the diode, of the energy contained in the coil itself. The following measurement is performed once again on the same relay. Operation times are given by the upper curve:

- time to start the movement 14ms
- transfer time 5ms

These times are multiplied by a coefficient from 4 to 8.

The lower curve shows the coil current. The increase prior to NO contact opening indicates that the contact spring dissipates its energy. At the opening time the current becomes constant as a result of practically zero opening speed.

Due to this kind of behavior, this type of suppression must be avoided for power relays. For small relays which have to switch low currents of less than 0.2 A, degradation of life is not that significant and the method may be acceptable.

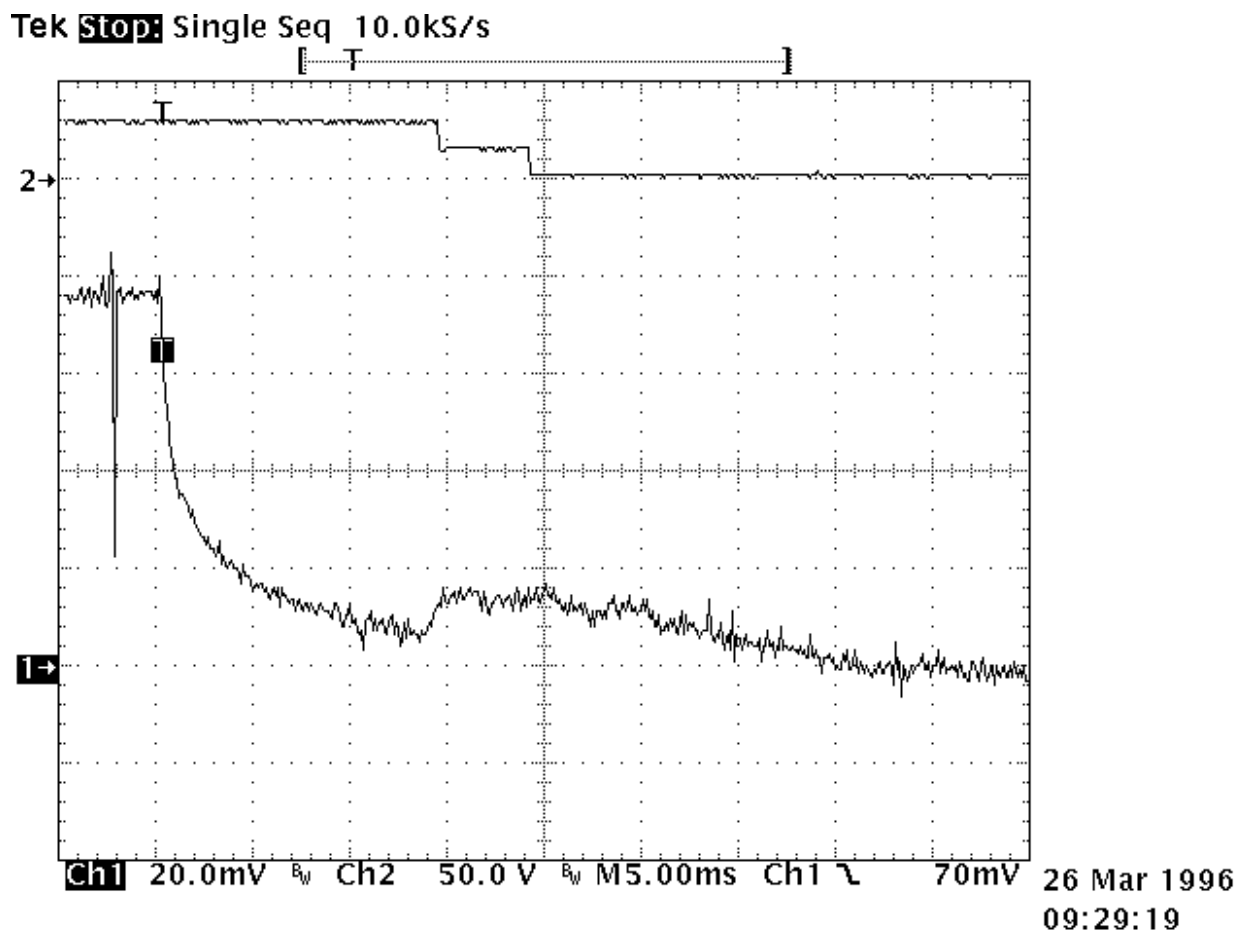

The diode + resistor network

It eliminates the inconvenience of the resistor alone, explained above, and it limits the action of a single diode. It is now preferred to use the diode + zener network.

The diode + zener network

Like the resistor, the zener allows a faster decurrent decay. In addition it introduces a threshold level for current conduction which avoids the recycling of energy released during contact movement.

The lower curve on the opposite record demonstrates those characteristics. Voltage limitation occurs at 42V. The two voltage spikes generated by internal movement are at lower levels than zener conduction. As a result, no current is recycled in the coil.

The opening time phases are as follows:

- time to start the movement 2.6ms
- total motion time 2.4ms
- transfer time 1.4ms

The release time is slightly increased. The contacts' opening speed remains unchanged.

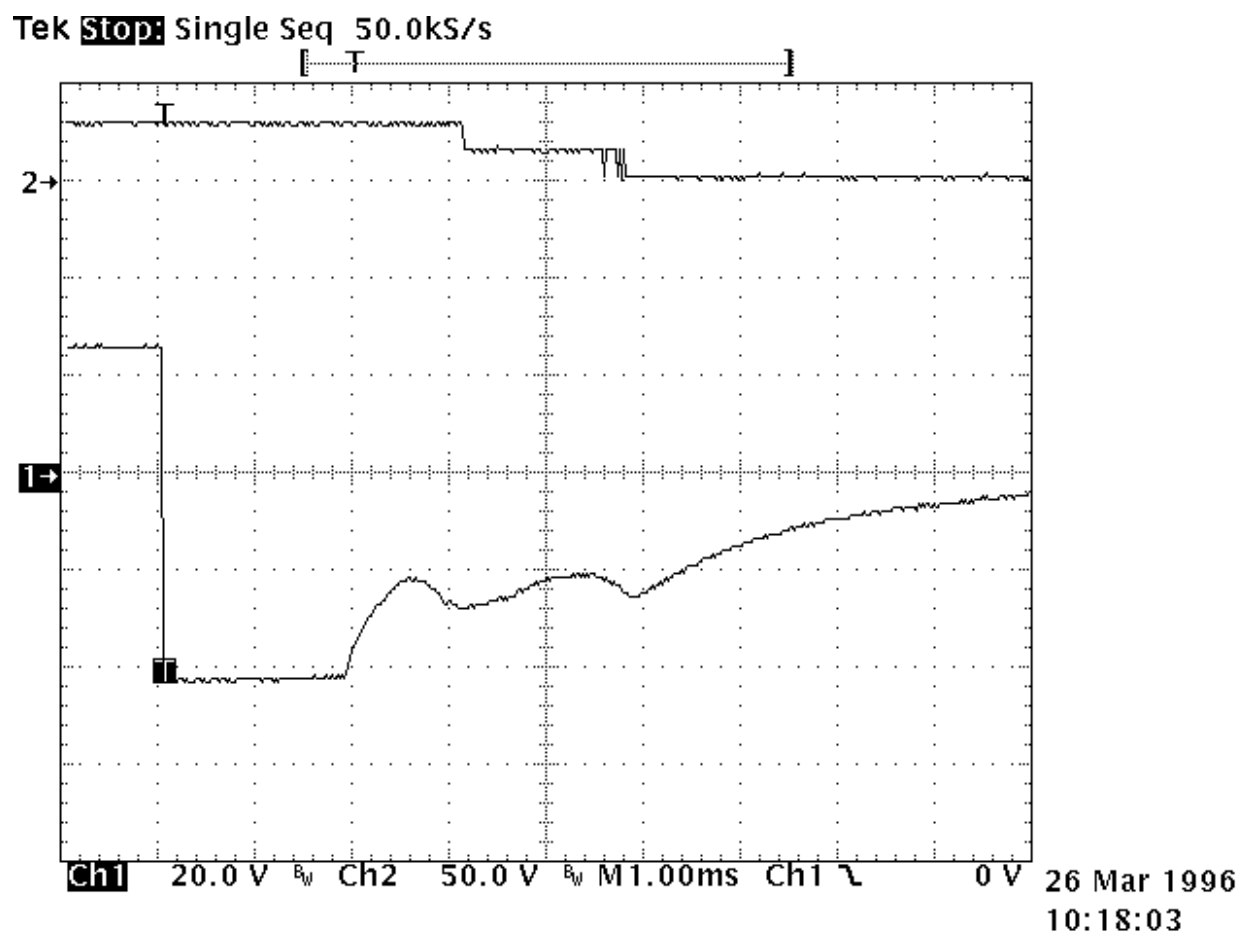

BASIC SOCKET SERIES DESIGNATION FOR:

SERIES F472, THLOR, THLM, THLC, THLHO

Socket for printed circuit board mounting

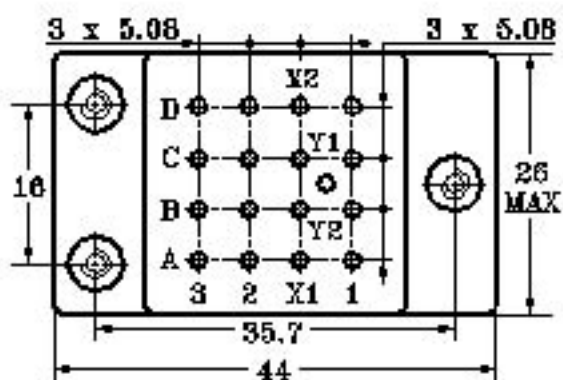
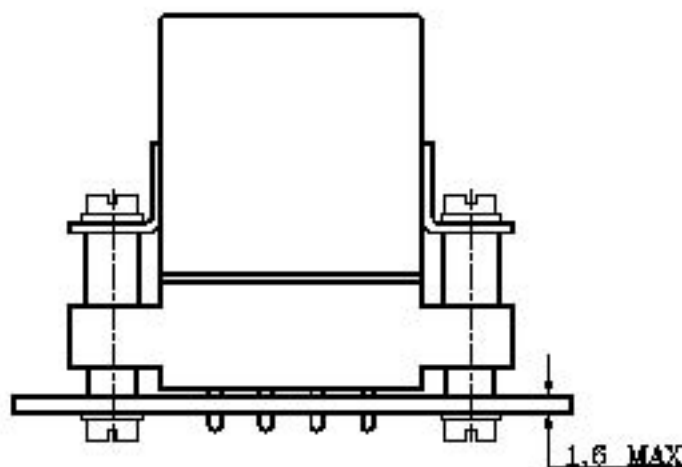
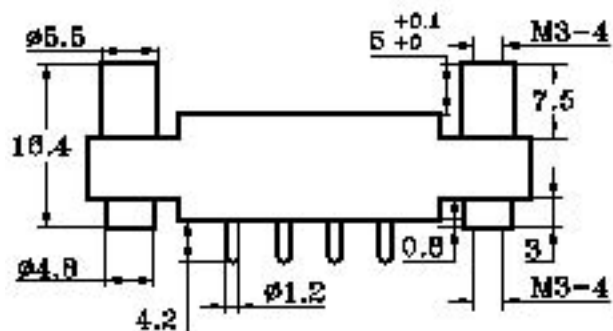

GENERAL CHARACTERISTICS

Temperature range	-55°C to +125°C
Storage temperature	-70°C to +150°C
Insulation resistance	> 1000 MΩ
Dielectric strength	
- Pins to mounting hardware	1500 Vrms / 50 Hz
- Between pins	1500 Vrms / 50 Hz
Sinusoidal vibration	20 g / 10 to 2000 Hz
Shock	50 g / 11 ms
Mounting hardware provided	6 screw M3-5



Featuring **LEACH**® power and control solutions
www.leachintl.com

AMERICAS
 6900 Orangethorpe Ave.
 P.O. Box 5032
 Buena Park, CA 90622 USA

Tel: (01) 714-736-7599
 Fax: (01) 714-670-1145

EUROPE
 2 Rue Goethe
 57430 Sarralbe
 France

Tel: (33) 3 87 97 31 01
 Fax: (33) 3 87 97 96 86

ASIA
 Room 501, 5/F, The Centre Mark
 287 - 299 Queen's Road Central
 Hong Kong

Tel: (852) 2 191 3830
 Fax: (852) 2 389 5803

Data sheets are for initial product selection and comparison. Contact Leach International prior to choosing a component.

ENGINEERING DATA SHEET

SERIES SF402-1F

RAILWAY SOCKET
BASE - H MOUNTING STYLE



BASIC SOCKET SERIES DESIGNATION FOR:
Series F472, FD472, THLOR, THLM, THLC, THLAO

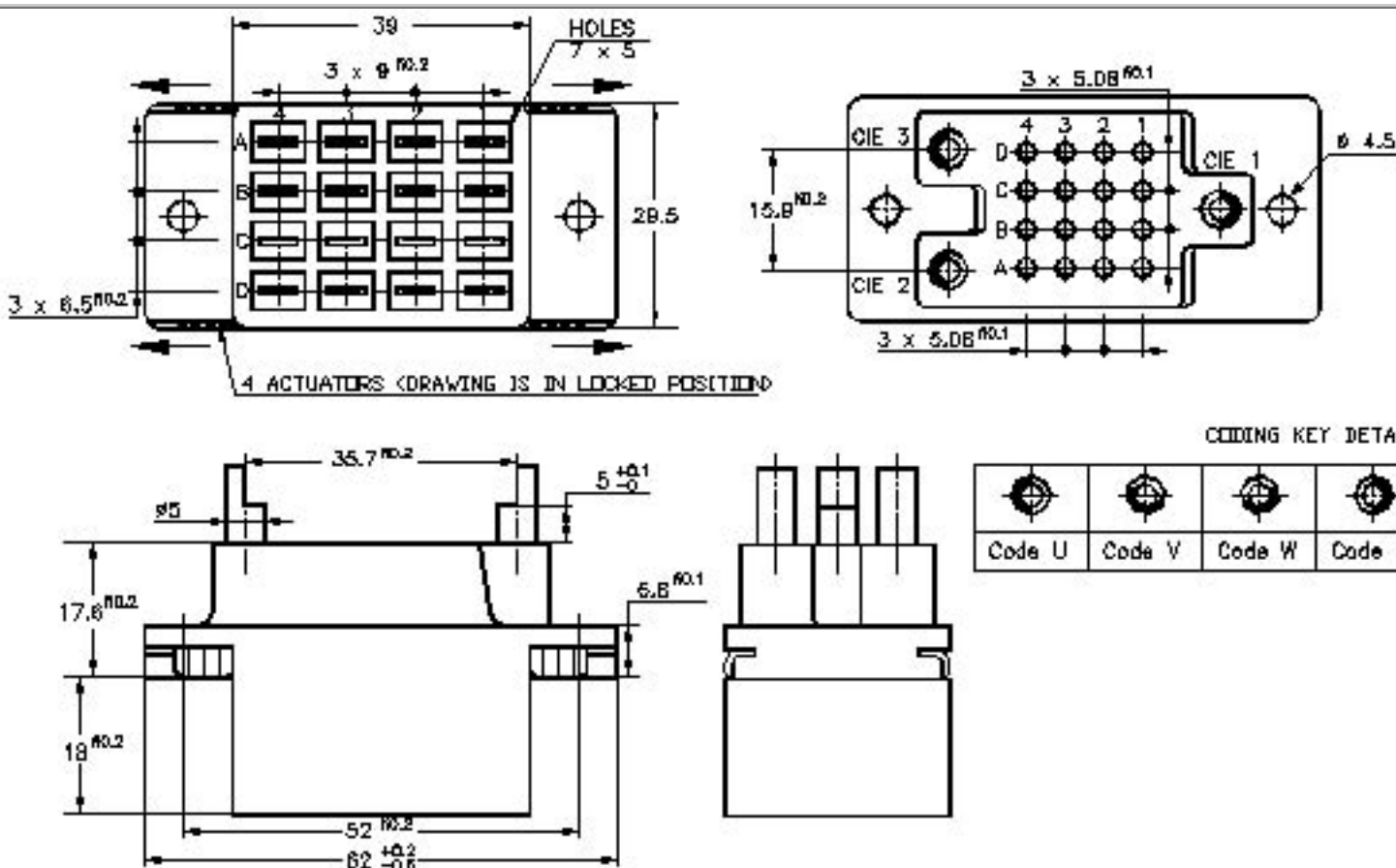

GENERAL CHARACTERISTICS

Base for F472 relay series with H mounting style. Foolproof mounting of the relay ensured by 3 keys according to NF F 62-002-2 FF n°8

Connections by 5 mm tabs according to ST363C

Contact Resistance	<5 mΩ
Maximum Current	15 Amps
Dielectric Strength	2625 Vrms / 50 HZ
Insulation Resistance	> 1000 MΩ at 100 Vdc
Weight	70 grams



Featuring **LEACH**® power and control solutions
www.leachintl.com

AMERICAS
6900 Orangethorpe Ave.
P.O. Box 5032
Buena Park, CA 90622 USA

EUROPE
2 Rue Goethe
57430 Sarralbe
France

ASIA
Room 501, 5/F, The Centre Mark
287 - 299 Queen's Road Central
Hong Kong

Tel: (01) 714-736-7599
Fax: (01) 714-670-1145

Tel: (33) 3 87 97 31 01
Fax: (33) 3 87 97 96 86

Tel: (852) 2 191 3830
Fax: (852) 2 389 5803

Data sheets are for initial product selection and comparison. Contact Leach International prior to choosing a component.

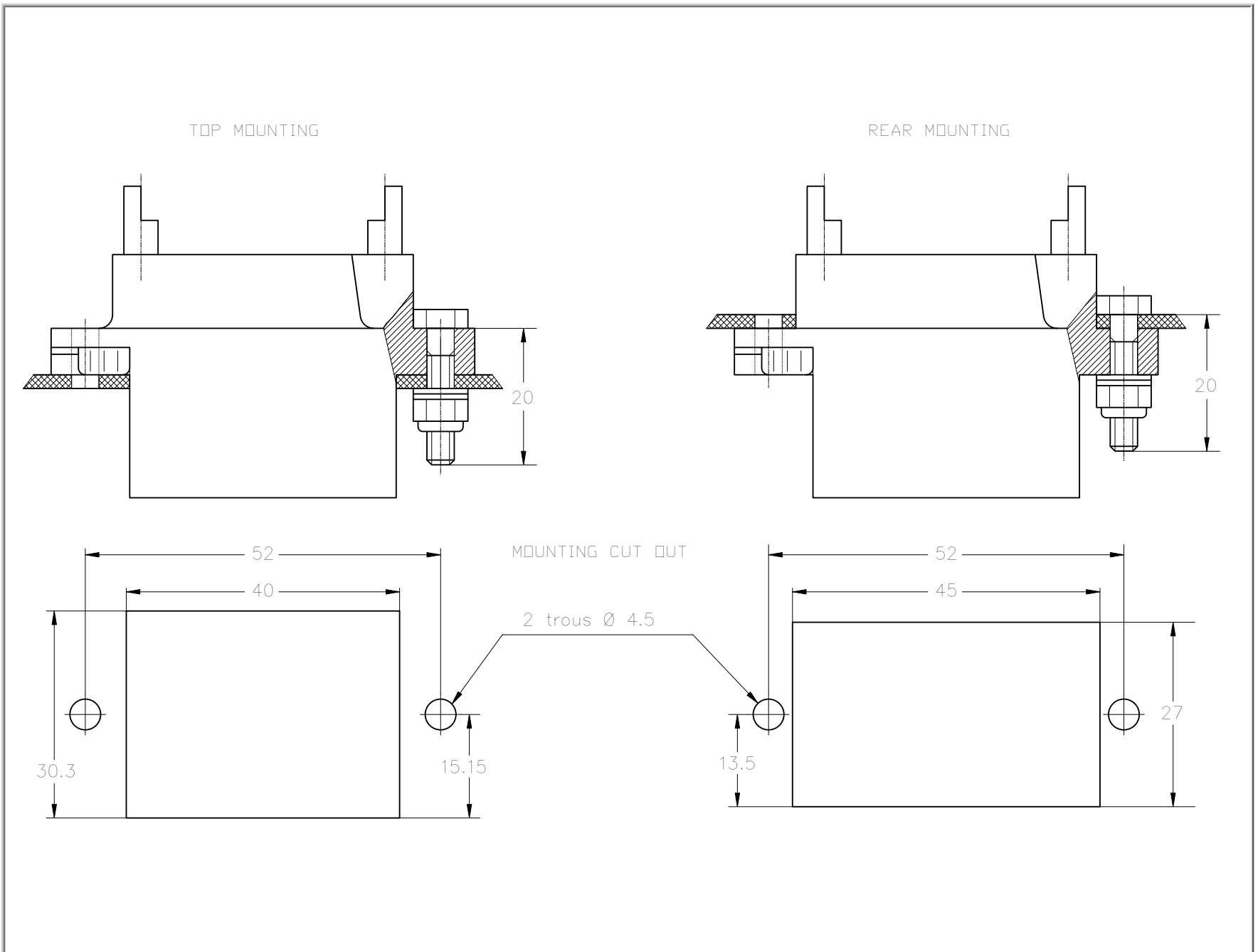

- Hardware:** (supplied with socket)
- 2 studs M4 - 2 self-locking nuts M4
 - 2 flat washers - 2 crinkle washers.