

M56748FP

4-CHANNEL ACTUATOR MOTOR DRIVER

DESCRIPTION

The M56748FP is a semiconductor IC developed as the motor driver used to CD player, CD-ROM.

This circuit includes Standby circuit, TSD circuit and 4-Channel BTL Driver that is able to drive four actuator with one IC.

FEATURES

- Low Output saturation voltage (typ:1.35V, at 0.5A)
- Large Operating supply voltage range (4.5 – 15V)
- Minimum Crossover distortion

APPLICATION

CD player, CD-ROM, Video CD

PIN CONFIGURATION (TOP VIEW)

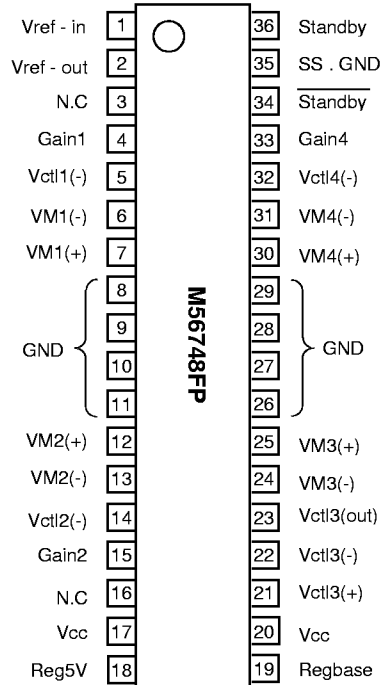

Outline 36P2R-D

N.C : no connection

BLOCK DIAGRAM

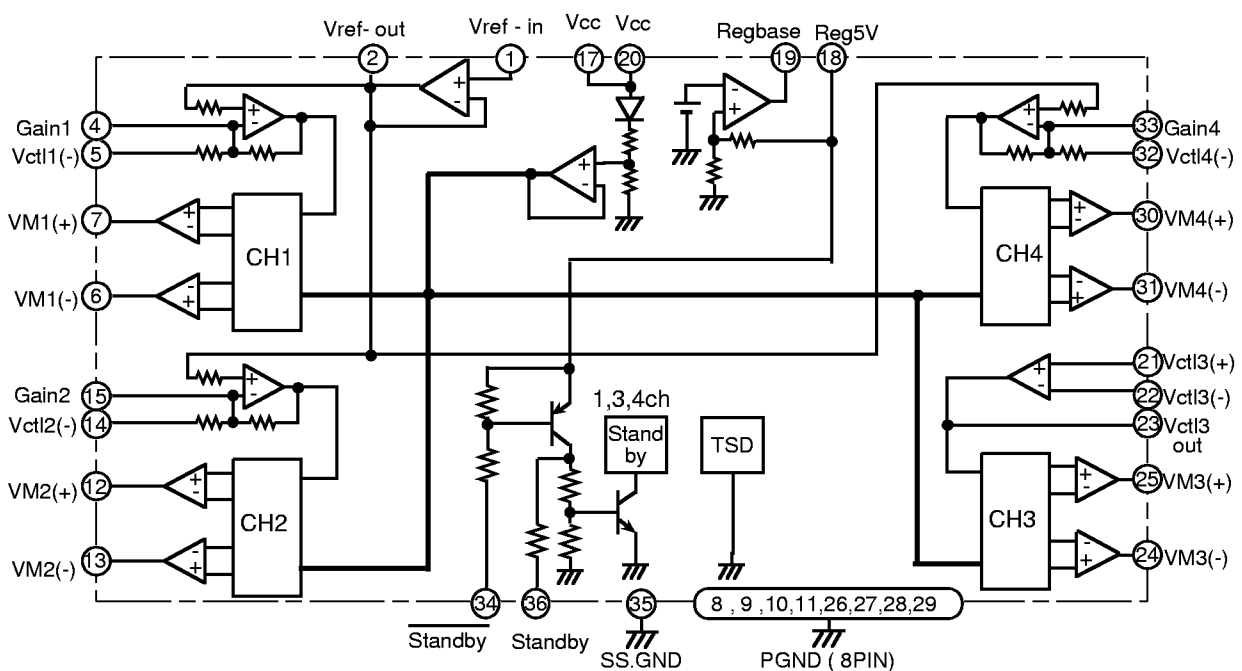

PIN DESCRIPTIONS

Pin No.	Symbol	Function	Pin No.	Symbol	Function
①	Vref-in	Reference voltage input terminal	⑲	Reg-base	Connects the base of external PNP
②	Vref-out	Reference voltage output terminal	⑳	Vcc	Power supply
③	N.C		㉑	Vctl3(+)	CH3 amp. non-inverted input terminal
④	Gain1	CH1 amp. gain control terminal	㉒	Vctl3(-)	CH3 amp. inverted input terminal
⑤	Vctl1(-)	CH1 amp. inverted input terminal	㉓	Vctl3(out)	CH3 input amp. output terminal
⑥	VM1(-)	CH1 amp. inverted output terminal	㉔	VM3(-)	CH3 amp. inverted output terminal
⑦	VM1(+)	CH1 amp. non-inverted output terminal	㉕	VM3(+)	CH3 amp. non-inverted output terminal
⑧ to ⑪	GND	GND	㉖ to ㉙	GND	GND
⑫	VM2(+)	CH2 amp. non-inverted output terminal	⑳	VM4(+)	CH4 amp. non-inverted output terminal
⑬	VM2(-)	CH2 amp. inverted output terminal	㉑	VM4(-)	CH4 amp. inverted output terminal
⑭	Vctl2(-)	CH2 amp. inverted input terminal	㉒	Vctl4(-)	CH4 amp. inverted input terminal
⑮	Gain2	CH2 amp. gain control terminal	㉓	Gain4	CH4 amp. gain control terminal
⑯	N.C		㉔	Standby	L standby input terminal
⑰	Vcc	Power supply	㉕	SS. GND	Small signal GND
⑱	Reg5V	Connects the collector of external PNP	㉖	Standby	H standby input terminal

ABSOLUTE MAXIMUM RATINGS (Ta=25°C)

Symbol	Parameter	Condition	Rating	Unit
Vcc	Supply Voltage	⑰, ⑳ pin	15	V
Io	Output Current		700	mA
Vin	Maximum Input Voltage of each Terminals	①, ④, ⑤, ⑭, ⑮, ㉒, ㉓, ㉔, ㉕, ㉖, ㉗ pin	0 – Vcc	V
Pt	Power Dissipation	With infinite heatsink	4.5	W
Kθ	Thermal derating	With infinite heatsink	27.8	°C/W
Tj	Junction temperature		150	°C
Topr	Operating temperature		-20 – 75	°C
Tstg	Storage temperature		-40 – 125	°C

RECOMMENDED OPERATING CONDITIONS

Symbol	Parameter	Limits			Unit
		Min.	Typ.	Max.	
Vcc	Supply voltage	4.5	5.0	5.5	V
Io	Output current	—	—	500	mA

ELECTRICAL CHARACTERISTICS (Ta=25°C, Vcc=5V, unless otherwise noted)

Symbol	Parameter	Test conditions	Limits			Unit
			Min.	Typ.	Max.	
Icc1	Circuit current on no-signal	Vref=Vctl=2.5V	—	15	25	mA
Vsat	Output saturation voltage	Top and Bottom saturation voltage of output power Tr. Load Current Io=0.5A	—	1.35	1.90	V
Vofs 1	Output offset voltage-1	CH1, 2, 4, Vref=Vctl=2.5V	-35	—	+35	mV
Vofs 2	Output offset voltage-2	CH3, Vref=Vctl=2.5V	-57	—	+57	
Gv	Voltage gain between input and output	CH1, 2, 4	7.60	8.52	9.35	dB
		CH3 uses input amp. as a buffer.	13.6	14.54	15.4	
Standby	H standby-on voltage	CH1, 3, 4 = Standby ON	2.0	—	—	V
	H standby-off voltage	CH1, 3, 4 = Standby OFF	—	—	0.8	V
Standby	L standby-on voltage	CH1, 3, 4 = Standby ON, ⑱ pin = 5V	—	—	2.0	V
	L standby-off voltage	CH1, 3, 4 = Standby OFF, ⑱ pin = 5V	4.0	—	—	V

EXPLANATION OF OPERATION

1. The characteristics between Control voltage and Output voltage

CH1, CH2, CH4 AMP.

The input Amp. (Vctl terminal) consists of the Inverted Amp. and the output (VM+, VM-) is amplified by the different voltage between Vref and Vctl. The voltage gain of this input Amp. is 1 time.

Also, the output Amp. is the Master-Slave constitution. Each of Master Amp. (VM+) and Slave Amp. (VM-) have the gain of 1.33 times and the output voltage refer to the about Vcc/2.

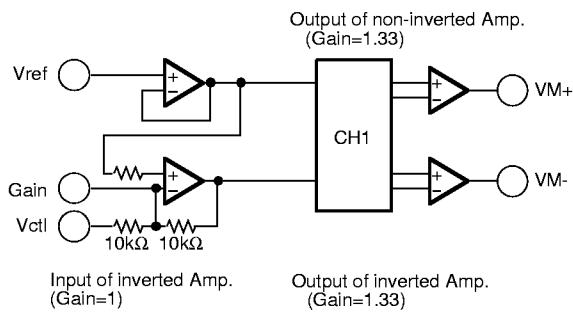

CH3 AMP.

The three terminals (Inverted, non-inverted and output) of Input Amp. go to external pins. So, the Amp. constitution (for example, Buffer Amp.) and the Gain can be adjusted by the external resistors.

The output Amp., is the same with CH1, 2 and 4, is consisted of the Master-Slave Amp. Each of the Master Amp. (VM+) and Slave Amp. (VM-) have the gain of 2.66 and the output voltage refer to the about Vcc/2.

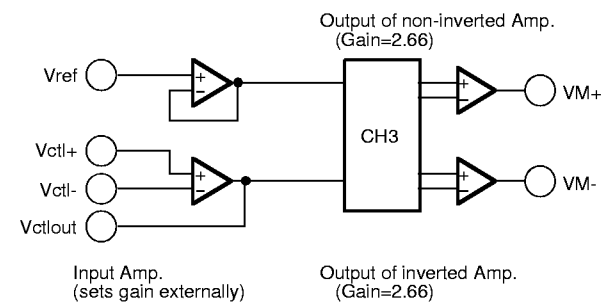

CH1, 2, 4 Amp.

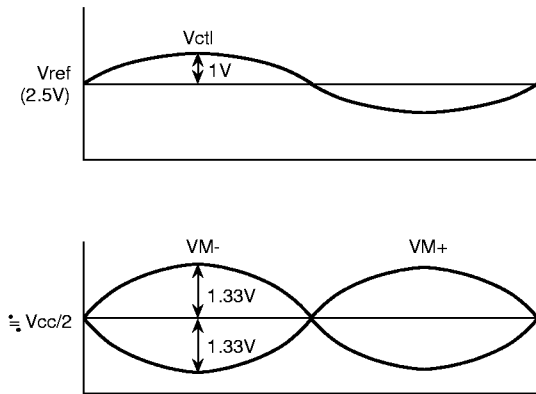

$$\text{Gain} = \frac{2.66\text{V}}{1\text{V}}$$

$$= 2.66 \text{ TIMES}$$

$$= 8.5 \text{ db}$$

CH3 Amp. (uses input Amp. as a Buffer Amp.)

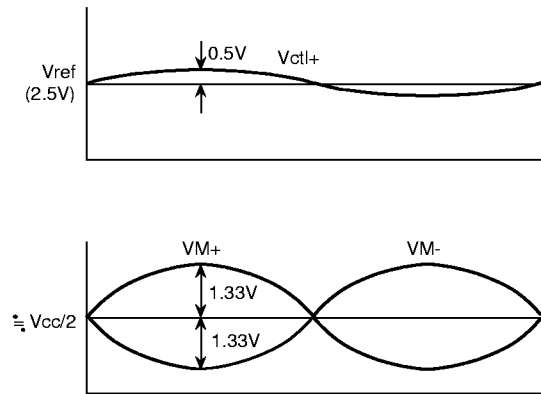

$$\text{Gain} = \frac{2.66\text{V}}{0.5\text{V}}$$

$$= 5.32 \text{ TIMES}$$

$$= 14.5 \text{ db}$$

TYPICAL CHARACTERISTICS

Output saturation voltage–Load current characteristics (Vcc=5V)

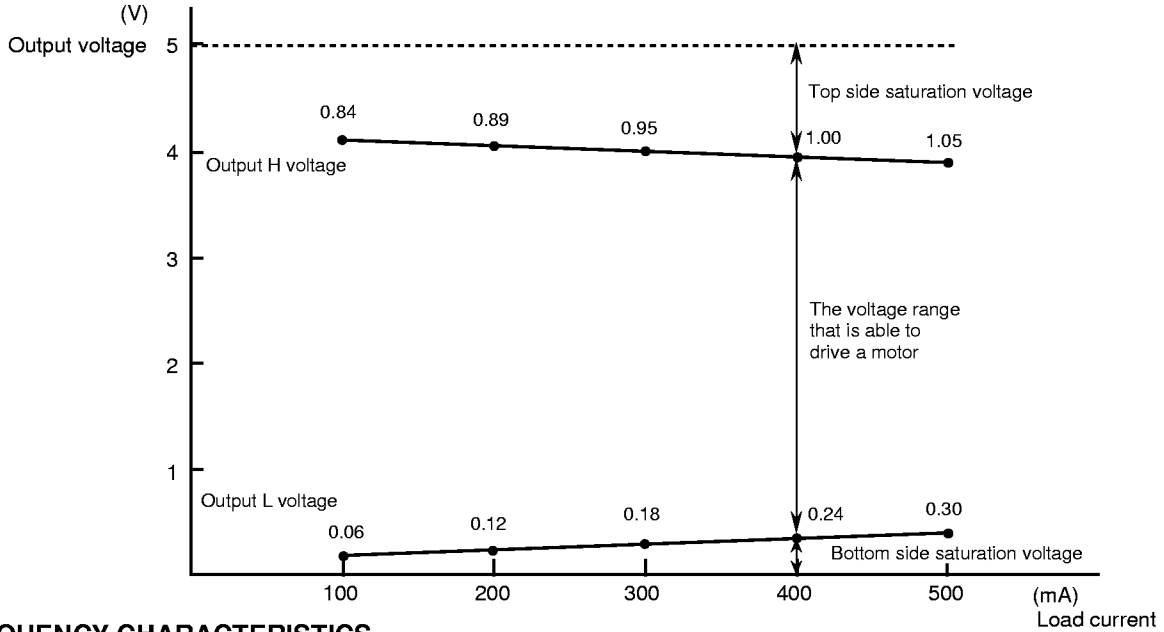

FREQUENCY CHARACTERISTICS

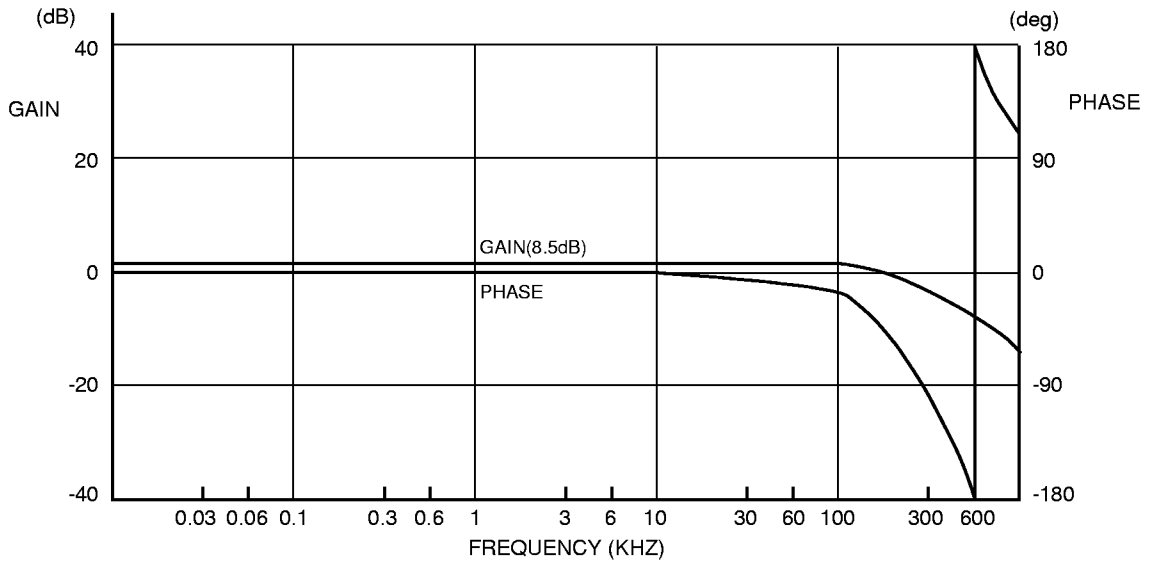

THERMAL DERATING

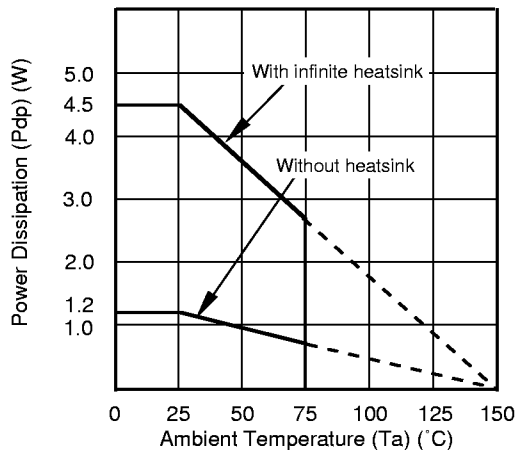

Application Example

